

Anatometric Point Guide for Canine Cranial Cruciate Ligament Suture Repair



A Major Qualifying Project Report
Submitted to the Faculty of
WORCESTER POLYTECHNIC INSTITUTE



In partial fulfillment of the requirements for
Degree of Bachelor of Science

Submitted by:

Roman Gutierrez

Brittany Rhodes

Aimee St. Germain

Elliott Wiegman

Submitted to:

Glenn Gaudette



Date of Submission: April 27, 2015

Contents

Authorship.....	4
Table of Figures	5
Table of Tables	6
Chapter 1: Introduction.....	7
Chapter 2: Literature Review.....	11
2.1 Cranial Cruciate Ligament	11
Biomechanics of the CCL.....	13
2.2 Cranial Cruciate Ligament Injuries	14
2.3 CCL Repair Options.....	15
2.3.1 Osteotomy Repair Techniques.....	16
2.3.2 Suture Repair Techniques.....	17
2.3.3 Failed suture placement	18
2.4 Isometric Points.....	19
2.5 Surgical Aiming Guides	21
3.5.1 Visual Guiding Devices.....	21
3.5.2 Mechanical Guidance	24
2.6 Gap in Current Research	28
Chapter 3: Project Strategy.....	29
3.1 Initial Client Statement.....	29
3.2 Objectives.....	29
3.2.1 Accuracy and Precision	29
3.2.2 Safety	29
3.2.3 Reusable.....	30
3.2.4 Universal.....	30
3.2.5 User Friendly	30
3.2.6 Ergonomic	30
3.2.7 Pairwise Comparison Chart	31
3.3 Constraints.....	32
3.3.1 Accurately locate points to nearest $\pm 2\text{mm}$	32
3.3.2 Size of device.....	32
3.3.3 Cost.....	32

3.3.4 Training time	32
3.3.5 Testing	33
3.4 Functions	33
3.5 Revised Client Statement	33
3.6 Strategy for Finding the Most Isometric Points	34
Chapter 4: Alternative Designs	35
4.1 Needs analysis	35
4.2 Conceptual Design #1	35
4.3 Conceptual Design #2	36
4.4 Conceptual Design #3	39
4.5 Feasibility and Design Selection:	41
4.6 Design Functions:.....	43
4.7 Optimization and Decisions	45
4.8 Design specifications:	47
Chapter 5: Design Verification	49
5.1 Questionnaire Development.....	49
5.2 Surgeon Validation.....	49
Chapter 6: Discussion	51
6.1 Limitations	51
6.2 Impact.....	51
Chapter 7: Final Design	55
Chapter 8: Conclusions and Recommendations	57
References.....	58
Appendix A:.....	60
Appendix B: Blank Surgeon Questionnaire.....	64
Appendix C: Surgeon Questionnaire - Dr. Faircloth	66
Appendix D: Surgeon Questionnaire - Dr. Murphy.....	68
Appendix E: Marketing Brochure.....	71
Appendix F: Device Instructions	73
Appendix G: Dimension Table	77

Authorship

All authors contributed equally to the writing of this report.

Table of Figures

Figure 1: Canine Directional Terms	11
Figure 2: CCL Anatomy (Muir, 2011).....	12
Figure 3: Healthy Ligament Tensile Results (Muir, 2011).....	13
Figure 4: Collagen Structure (Muir, 2011)	14
Figure 5: Tibial Tuberosity Advancement Procedure (American College of Veterinary Surgeons, 2014)	16
Figure 6: Tibial-plateau-leveling osteotomy procedure (American College of Veterinary Surgeons, 2014)	17
Figure 7: Lateral Suture Stabilization Techniques; from left to right: Lateral Fabello-tibial, Lateral Bone Anchor-Tibial, and Lateral Bone Tunnel (Kazanovicz, 2014).....	18
Figure 8: Radiolucent Aiming Guide (Wilson, 2003)	22
Figure 9: Coaxial laser targeting device (Trecha, 1991).....	23
Figure 10: C-arm Fluoroscope (Barrick, 1998)	24
Figure 11: Tool guide in use on joint (Fox, 1988).....	25
Figure 12: Ranges of motion of tool guide (Fox, 1988)	26
Figure 13: a) Gerdy’s Tubercle marked by a green spot (Rubel, Schwarzbard, Leonard, & Cece, 2004) b)Extracapsular surgical procedure device (White, 2011)	27
Figure 14: Extracapsular surgical procedure device fixated to bone (White, 2011)	28
Figure 15: Most anatometric points, represented by the femoral point F2 and the tibial point T8	34
Figure 16: Precise measurements to the locations of the most anatometric points	34
Figure 17: Left: Femur Piece; Right: Tibia Piece	36
Figure 18: Two projector design iterations.....	38
Figure 19: (Clock-wise from Top-Left) Straight, Curved, Angled, and Form Fit Bar Iterations	40
Figure 20: Basic Four Bar Linkage Conceptual Design	41
Figure 21: Projector Design Idea Proof of Concept.....	42
Figure 22: 3-D Model of the Stifle with Curved Linkage	45
Figure 23: Four Bar Linkage Design Iterations	47
Figure 24: (a) Landmarks (b) Dimensions of the Bottom Bar.....	48
Figure 26: Final design of the Anatometric Point Guide.....	56

Table of Tables

Table 1: Pairwise Comparison Chart	31
Table 2: Function Means Chart.....	44
Table 3: Summary of Surgeon Responses	50

Chapter 1: Introduction

Cranial Cruciate Ligament Disease (CCLD), a common condition in dogs, occurs when the Cranial Cruciate Ligament (CCL), the equivalent of the anterior cruciate ligament in humans, is damaged or deteriorated (Tonks, 2009). CCL tears are the most common hind limb lameness-causing injury. Each year, pet owners spend \$1.3 billion on canine CCL surgeries (Wilke, Robinson, Evans, Rothschild, & Conzemius, 2005). Treatment options for CCLD include non-surgical rehabilitation as well as several surgical techniques; the most common of the surgical options is called Lateral Suture Stabilization (LSS) (Fischer, Cherres, Grevel, Oechtering, & Bottcher, 2010). In LSS, a nylon suture stretches between a point on the femur and a point on the tibia to mimic mechanical functions of the CCL (Tonks, 2009). The suture stabilizes the joint and minimizes femoral translation across the tibia during range of motion (Roe, Kue, & Gemma, 2008). Without surgical intervention, anywhere between 40% and 50% of canines with CCL tears will rupture the CCL on the opposite leg as a result (Cranial Cruciate Ligament Disease, 2014). LSS procedures range from \$500 to \$2,500 (Colorado State Veterinary Hospital). This price does not include any possible further complications due to failed suture attachments from the LSS procedure.

The locations of both ends of the suture in LSS procedures are vital for proper function and recovery. Ideally, the distance between these two attachment points remains constant during the range of motion, as limited change in distance results in a constant level of strain on the nylon suture. Incorrect placement of the femoral and tibial anchors results in ineffective functionality, ruptured sutures, arthritis, and further stifle damage. Attachment points that stretches the suture too much do not allow the joint to complete the full range of motion, and often causes suture rupture post-surgery and additional damage to the stifle joint (Fischer et al., 2010). In spite of the importance of attachment points, there is very limited data to support ideal anchor and suture attachment

locations. Isometric points, points that remain exactly the same distance from each other during the whole range of motion, do not exist in a hinge joint, like the stifle, complicating the procedure. Basic guidelines for suture placement are available, but there is no definitive research for femoral and tibial points that allow for an optimal range of motion and stability. Veterinary surgeons have no option but to estimate the location of the attachment points of the suture during each surgery, and have no way of reliably and accurately fixating the sutures in canines. After suture failures, pet owners frequently spend even more money on rehabilitation costs and additional repair surgeries to allow the dog to remain mobile (Kazanovicz, 2014).

The goal of the project was to improve the success rate of a specific type of LSS procedure, Extracapsular Lateral Bone Anchor Tibial Suture Fixation. Extracapsular Suture (ES) repair is a type of LSS and Lateral Bone Anchor Tibial Suture Fixation is a type of ES. Three different objectives were completed that allowed the team to achieve the goal. Existing research was combined with data obtained from three different testing methods to determine the joint's most isometric points. The second objective was to create a guide device that allows surgeons to consistently and accurately locate these isometric points during a surgery. To aid in the promotion of the device, the third objective was to design an instructional manual and a model that explains the need for the aiming device to pet owners and surgeons.

In order to address current, unrepeatability procedures for suture attachment, it was necessary to locate the femoral and tibial points needed for CCL lateral suture repair. The canine stifle is much like a hinge. Since there is no true isometric points on a hinge, SECUROS created the term "anatometric" to refer to points where sutures remain taught throughout the whole range of motion. This word comes from the terms isometric and anatomy, as the research was based on the most isometric regions, but also taking into consideration the anatomy of the stifle. The attachment sites

may vary based on dog size and breed, so midsized dogs (30 to 60 lbs.) were the main focus of this research.

Once the anatometric points were found, a device was created to assist the surgeon in finding them. To assist in the correct use of the device, instructional material was created to accompany the device. This additional material will ensure the device is used to its full potential without risk or harm to the surgeon or dog.

Lastly, a visual aid was created to explain the underlying need for research of anatometric points and the relevance of the device. Surgeons and pet owners are not aware of the precision required in this type of surgery. The model makes the problem of improper suture placement easier to explain. It will be used to help with the sales of the point guide by emphasizing its necessity, as well as help raise awareness of the consequences of misplacement of the suture points.

In order to define these anatometric regions, stifle movement *in vivo* via fluoroscopy was observed. From this research, the joint's range of motion was studied in depth. Frames from the videos were analyzed by measuring all locations on the distal end of the femur against the proximal end of the tibia to determine which combinations had the most anatometric points. These videos gave a baseline of how the stifle operates while weight-bearing.

Mechanical and visual tests were also completed on saw bones and cadavers. These tests allowed the team to set the stifle at a specific angle within the range of motion and record measurements between different femoral-tibial point combinations. This data was combined with the fluoroscopy videos to help narrow down the selection of point combinations.

Once the anatometric region locations were located and narrowed down to three potential selections, the team validated the combinations by performing cyclic tests on the sutures attached to

the hypothesized regions on nine cadaver stifles. Testing the sutures mechanically confirmed the most anatomic points on the stifle of a mid-sized dog.

In order to make the device, the team began the design process by creating multiple design possibilities, performing design analysis, deciding on a prototype, and, finally, refining it based on veterinary surgeon feedback. This device works to specifically locate the anatomic points found within the mechanical and visual testing completed prior to the device design.

Lastly, to market the device to surgeons, the problem and need were defined using a visual aid. The visual aid gives basic instructions on how the point location device operates and its specific ability to improve the success rate of LSS surgeries.

Chapter 2: Literature Review

Canine CCL disease is a common and significant medical issue for canines. Increased research of and proficiency with CCL repair techniques has amplified the market potential. From research conducted in 2003, pet owners spent \$1.3 billion on CCL repairs for their canines annually. In comparison, the human ACL repair industry is approximately \$2 billion annually. CCL injuries account for approximately ninety percent of canine stifle injuries. Additionally, complication rates for CCL repairs are quite high. As a result, CCL repair procedures need further research and refinement (Kazanovicz, 2014).

2.1 Cranial Cruciate Ligament

Before the specifics of canine cranial cruciate ligament are discussed, it must be noted that there are many terminological differences between human and canine anatomy. Since canines are quadrupeds, there are more directional terms. These terms are explained in detail in Figure 1 on a quadrupedal animal. Additionally, the hind limb joint, the equivalent of the human knee, is called the canine stifle.

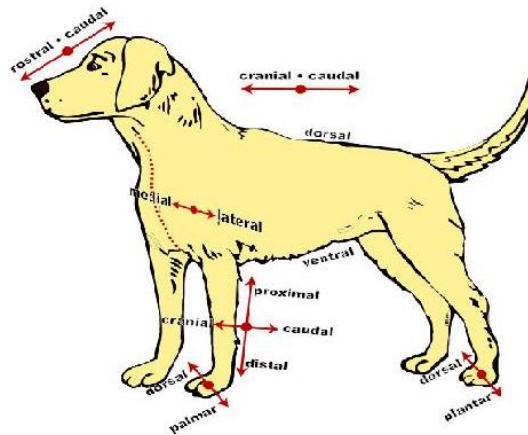
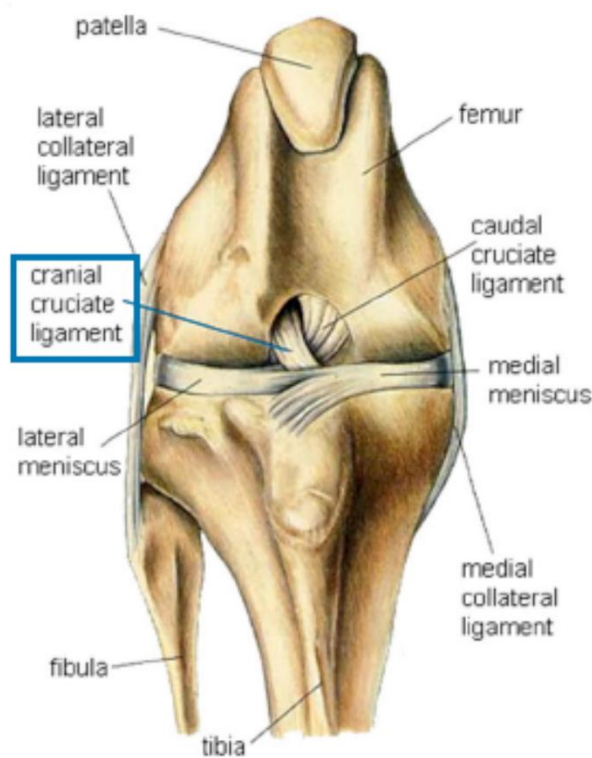
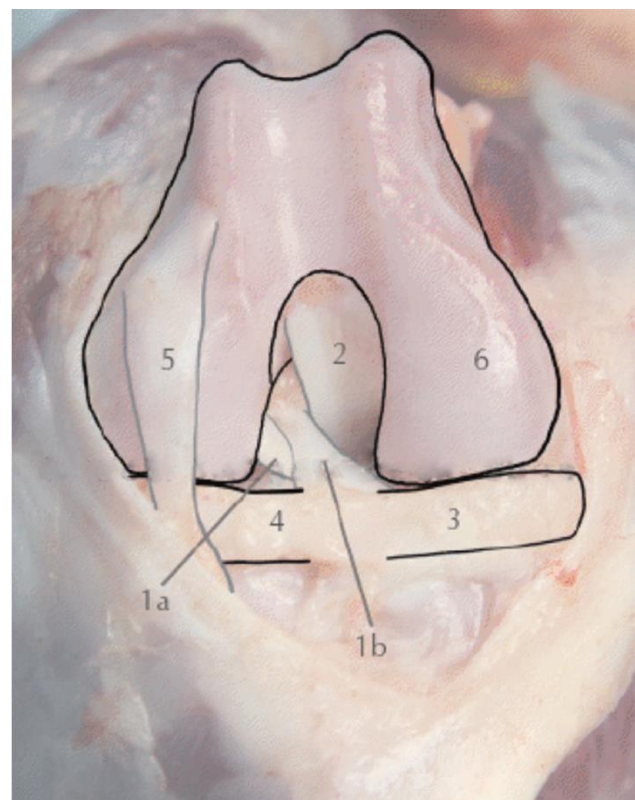

Figure 1: Canine Directional Terms

The CCL is located in the synovial joint capsule of the stifle and prevents cranial tibial translation. This translation can be dangerous and painful for the animal. As can be seen in Figure 2 (a) (Muir, 2011), the ligament originates on the axial aspect of the lateral femoral condyle. The ligament extends diagonally across the joint, and its length ranges between 13.5 and 18.8 mm, depending on the weight of the dog. The ligament is composed of two bundles, which are named after their attachment sites relative to the tibial plateau: craniomedial bundle, shown as 1b in the figure below, and the caudolateral bundle, shown as 1a in the figure below (Figure 2 (b)) (Muir, 2011). These two are slightly different. The craniomedial bundle is longer and thinner, while the caudolateral component is tougher and composed of thicker collagen fibrils.



(a)



(b)

Figure 2: CCL Anatomy (Muir, 2011)

Biomechanics of the CCL

Similar human ligaments, canine ligaments are composed of a combination of collagen fibrils, elastin, and proteoglycans. Collagen fibrils make up the majority of the ligament. These fibrils are highly aligned in the direction of the forces to which the ligament is normally subject. Collagen has finite properties, so the strength of ligament varies with the amount of fibrils – the more collagen fibrils, the thicker the collagen fibers. The combination of the relatively stiff collagen fibers and elastin, a very elastic material, gives the ligament viscoelastic properties. This behavior can be seen when the ligament is subject to tensile testing. Results from a healthy ligament tensile test can be seen in Figure 3. The figure displays three separate regions of viscoelastic behavior. The first region is non-linear and is a result of the crimping characteristic of collagen fibers (Figure 4) and the elastic properties of the elastin. As the force is further applied to the ligament, the nonlinear waves, seen on the fiber in Figure 4, created by the crimping are stretched, allowing for a relatively large amount of deformation with low forces. The next region is linear, and it represents the intrinsic strength of collagen. Finally, the deformation rate increases when the ligament fibers begin to rip, until eventual mechanical failure (Muir, 2011).

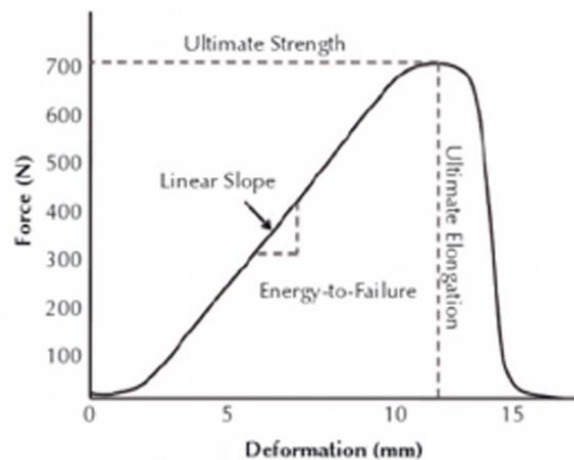

Figure 3: Healthy Ligament Tensile Results (Muir, 2011)

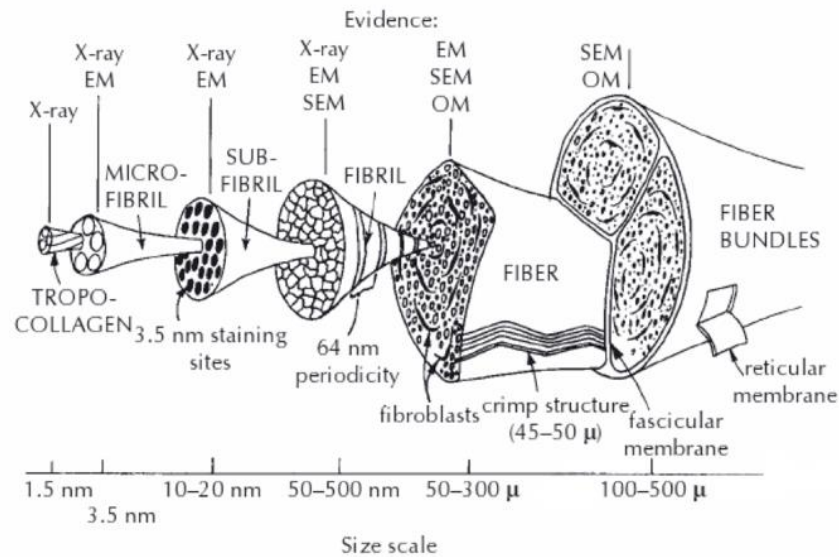

Figure 4: Collagen Structure (Muir, 2011)

2.2 Cranial Cruciate Ligament Injuries

Cranial cruciate ligament ruptures are a common occurrence in canines (Whitehair, Vasseur, & Willits, 1993). CCL ruptures are the most common cause of pelvic limb lameness and stifle joint osteoarthritis in canines (Bergh, Sullivan, Ferrell, Troy, & Budberg, 2014). Ruptures are rarely caused by trauma; they are usually caused by spontaneous incidents, and are usually associated with chronic degenerative disease. Ruptures of the CCL most frequently occur in large, young canines. A 1993 study showed that canines between the ages of 7-10 years old had the highest prevalence of rupture (Whitehair et al., 1993). Canines weighing greater than 22 kg had a higher prevalence of CCL rupture compared to lighter dogs. Certain breeds such as Rottweiler's, Newfoundland's, and Staffordshire Terriers had the highest prevalence among the breeds represented in the study (Whitehair et al., 1993).

A healthy canine stifle has a range of motion of approximately 120 degrees, going from 40 degrees in flexion, and 160 degrees in extension (Muir, 2011). The tibia rolls and glides past the

femoral condyle to complete the motion. It is important to note that the stifle joint is not a perfect hinge joint, and that the motion is not symmetrical. When the stifle joint is flexed, the lateral side experiences some caudal rotation. In a CCL-deficient stifle, the main difference in the motion is cranial tibial translation. Throughout the stance phase of the gait, an average translation of 10 mm was consistently observed through certain dog breeds with complete rupture of the CCL. Research has shown that the swing phase of the gait is not typically affected until 2 years after the injury, at which point the tibia shows an average cranial translation of 5 mm (Bergh et al., 2014).

CCL disease has a significant economic impact in today's world. In 2003, it was estimated that \$1.3 billion was spent on CCL surgery and treatment. Surgery is the most recommended form of treatment as it is a more rapid method for stifle joint stabilization. Most commonly performed surgical procedures include lateral extracapsular suture stabilization, tibial plateau leveling osteotomy, and tibial tuberosity advancement (Bergh et al., 2014).

2.3 CCL Repair Options

This project is focused specifically on the Lateral Extracapsular Suture Stabilization Technique. The procedure utilizes a suture that is secured through a hole in the tibia and attaches to the femur via a bone anchor. The particular placement stabilizes the stifle from translation. The main issue with the technique is that a high percentage of bone anchors are pulled out or the suture breaks when it is not positioned in an anatomic location on the femur and tibia. This occurs because of over-tensioning of the suture during parts of the range of motion. The stifle is no longer stabilized from translation once the suture is broken or no longer fixed to the femur (Fischer et al., 2010).

Damaged CCL's require repair or rehabilitation to allow for continued mobility in canines. Both nonsurgical and surgical options are available in order to treat CCL injuries. Activity restriction

and medications are options for some canines. Orthotics and Braces are additional examples of nonsurgical treatment options for major CCL sprains and tears. Both braces and orthotics have stabilizing components that limit translation and rotation of the canine stifle (Canapp, 2007). Surgeries are the most frequently utilized form of CCL repair and can take many forms. The general forms of surgical CCL treatment are suture techniques and osteotomy techniques.

2.3.1 Osteotomy Repair Techniques

Osteotomy repair techniques require the manipulation of bone structure in order to repair instability due to CCL damage. Tibial Tuberosity Advancement (TTA) changes the angle of the patellar ligament by advancing the tibial tuberosity. Figure 5 depicts the procedure.

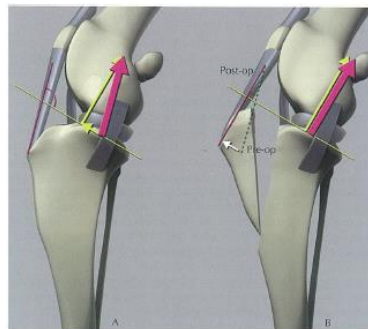

Figure 5: Tibial Tuberosity Advancement Procedure (American College of Veterinary Surgeons, 2014)

Once the bone has been cut and advanced, the bone is secured using a titanium plate to prevent the adjusted bone from moving. As a whole, this procedure reduces shear forces in the stifle and stabilizes the joint movements (Muir, 2011). From a study in 2006, TTA has a technical failure rate of 22% (American College of Veterinary Surgeons, 2014).

Tibial-plateau-leveling osteotomy (TPLO) is another procedure that manipulates bone form to correct instability due to CCL damage. The tibial plateau is cut and rotated, shown in Figure 6, to prevent femur translation across the tibia during stifle loading.

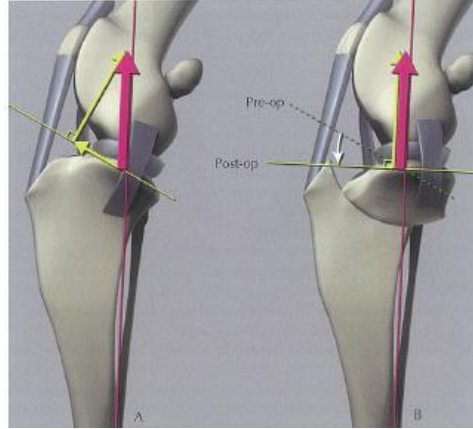

Figure 6: Tibial-plateau-leveling osteotomy procedure (American College of Veterinary Surgeons, 2014)

For both TPLO and TTA, the bone cuts are permanent and failures from the procedure are often catastrophic in nature and can result in amputation (Kazanovicz, 2014).

2.3.2 Suture Repair Techniques

Extracapsular sutures act to correct instability caused by a damaged CCL by resisting cranial tibial translation and internal rotation of the stifle joint (Kazanovicz, 2014). The most frequently used sutures are made of a multifilament nylon that has mechanical properties ideal for tensions within the stifle. Periarticular fibrosis, which is the encapsulation of the suture, occurs over time and ensures stifle joint stability ("SECUROS Catalog,"). It is important that the suture remains in tension throughout the entire range of motion (Roe et al., 2008). There are three notable forms of ES CCL repair: Lateral Fabello-Tibial Suture, Lateral Bone Anchor Tibial Suture, and Lateral Bone Tunnel Technique. These three procedures are shown in Figure 7 from right to left (Kazanovicz, 2014).

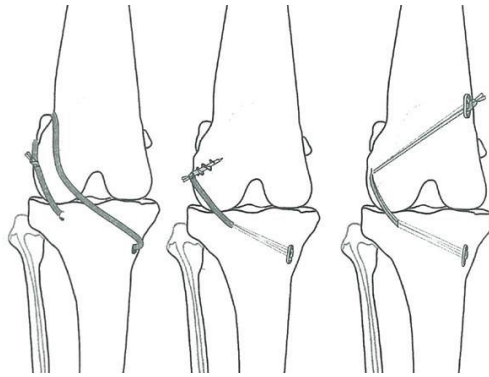

Figure 7: Lateral Suture Stabilization Techniques; from left to right: Lateral Fabello-tibial, Lateral Bone Anchor-Tibial, and Lateral Bone Tunnel (Kazanovicz, 2014)

2.3.2.1 Lateral Fabello-Tibial Suture

The Lateral Fabello-Tibial Suture involves the passing of a suture around the fabella, located on the femur, through a bone tunnel in the tibia, then passed back to the origin. The suture is then crimped at a tension of the surgeon's determination (Kazanovicz, 2014).

2.3.2.2 Lateral Bone Anchor Tibial Suture

Similar to the Lateral Fabello-Tibial Suture, the Lateral Bone Anchor Tibial Suture has a bone anchor on the femur, passes through a bone tunnel in the tibia and is crimped to a tension of the surgeon's determination (Kazanovicz, 2014).

2.3.2.3 Lateral Bone Tunnel Technique

The Lateral Bone Tunnel Technique, also known as the TightRope technique, has two bone tunnels. The suture passes through a tunnel in the femur and the tibia and is crimped at a tension of the surgeon's determination. The double tunnel allows for reduced likelihood of suture failure and loosening (Tonks, 2009).

2.3.3 Failed suture placement

Sutures fail due to a variety of causes. A suture that does not remain in tension throughout the whole range of motion will not stabilize the joint. Conversely, sutures that are too tight

throughout the whole range of motion will rupture when exposed to excess strain. Across all ES procedures, the tension in the suture is directly related to the points where it is anchored and attached. Currently, surgeons do not have a “gold standard” for anchoring and attachment sights. This lack of knowledge results in variations in suture tensions across procedures and veterinary surgeons (Roe et al., 2008).

2.4 Isometric Points

Finding accurate isometric points for suture attachment sites in CCL repairs has proven inconclusive in numerous studies. With a suture that is too tight, the tension will cause the suture to wear over time during extension as well as restrict movement of the stifle (Fischer et al., 2010). Different methods have been tested on many different combinations of attachment sites to test the isometric properties. The various testing methods conducted would see how the range of motion was affected, or the tension on the sutures after continuous loads. The majority of the tests conducted also explained how certain aspects in each study were not considered, proving that their results might not be completely precise.

The most conclusive of the research so far has shown a set of points that, through visual testing, was seen to be the most isometric position. The femoral attachment site was placed in the caudolateral femoral condyle at the distal pole of the lateral fabella. The tibial attachment site was placed at the bony protuberance 2mm caudal to the sulcus of the long digital tendon. When the CCL was intact, these points showed isometry when preloaded at 0 and 5 Newton’s. When the CCL was removed, the sutures stayed almost isometric when preloaded with 5, 10 and 15 Newton’s (Hulse et al., 2010). Other suture attachment sites proved to be close to isometric, but also not exact. For the first set of the points, the femoral location was on the caudolateral femoral condyle at the level of the proximal pole of the fabella. The tibial site was at the bony protuberance located 2mm caudal to the

sulcus of the long digital tendon (Hulse et al., 2010). For the second set of points, the femoral site is located at the distal pole of the fabella, and its tibial counterpart was located immediately caudal to the long digital extensor groove of the tibia (Hulse et al., 2010).

There was a different method used in each of the referenced articles. One of the tests exclusively focused on finding the distances between markers placed in suspected isometric points. For this test, the femur was anchored, and the tibia was left free to move in a natural motion. The tibia would then be manually moved to flex the joint at specific angles. At each of these angles, an x-ray was taken. The markers used to identify the suspected isometric points were radiopaque, and were easy to see in the x-ray. The distances between different combinations of markers were then measured with image analysis software. The most isometric points were determined to be those that had the least amount of change in distance throughout the range of motion of the stifle (Roe et al., 2008).

In the second article, the method was focused on the forces experienced by the sutures. Similar to the previously mentioned test, the femur was anchored, and the tibia was left able to complete its normal motion. The tibia was manually moved from 130 to 150 degrees of extension. A force gauge was attached to the suture to measure the forces it experiences throughout the range of motion. The most isometric points were determined to be those at which the sutures experienced the most constant amount of force.

While both of these tests used valid methods of testing, they were testing two different parameters that are both equally important. However, testing one without the other left doubts as to whether the research was accurate.

2.5 Surgical Aiming Guides

The following section will introduce surgical guidance tools encompassing both visual and mechanical methods for accurately locating key locations during orthopedic surgeries. The visual tools include the use of X-ray and fluoroscopic imagery systems and real-time surgical monitoring. Visual tools often allow for the surgeon to locate anatomy or implanted devices of the patient and complete the procedures with more accuracy. The mechanical tools stem from a compass-like design that allows for the surgeon to measure and pinpoint the distances between drill or attachment sites. Some of the tools also serve as drilling guides. Components of both varieties of tools should be considered for the design of the anatomic point guide and can assist in defining certain device characteristics for CCL suture placement.

3.5.1 Visual Guiding Devices

Radiolucent aiming guide

A radiolucent aiming guide is used in conjunction with X-ray visual monitoring in order to position the guide accurately over the bone in order to insert locking screws. The main purpose for this design is to insert locking screws into intramedullary nails. Intramedullary nails are inserted in the medullary canal of bone, which is the center cavity of the bone, and are used for healing bone fractures. Once the nail is placed into the medullary canal it must be secured using locking screws but it can no longer be seen, which is where this aiming device comes into play (Wilson, 2003).

Each radiolucent aiming guide is comprised of a radiolucent handle (meaning it is made of a material that cannot be seen under X-ray or other types of radiation), a protection sleeve, trocar, drill sleeve, and drill bit. The trocar is a sharp pointed surgical device that has an internal tube used for drainage. The aiming portions of the radiolucent handle and protection sleeve are radiopaque, which means those portions are opaque to X-rays or similar radiation. This property allows for easy visual positioning of the aiming holes and trocar of the device over the bone and intramedullary nail while

under X-ray. The trocar and protection sleeve are first positioned parallel to the X-ray beam. The radiopaque tips of the trocar and protection sleeve cast concentric circular images that can be seen on the X-ray monitor. From there, the guide position is adjusted until the circular images are aligned with the screw holes of the intramedullary nail. This device is shown in Figure 8 where the X-ray beam is passing through the radiolucent trocar, handle, and protection sleeve before it reaches the bone and receiver (Wilson, 2003).

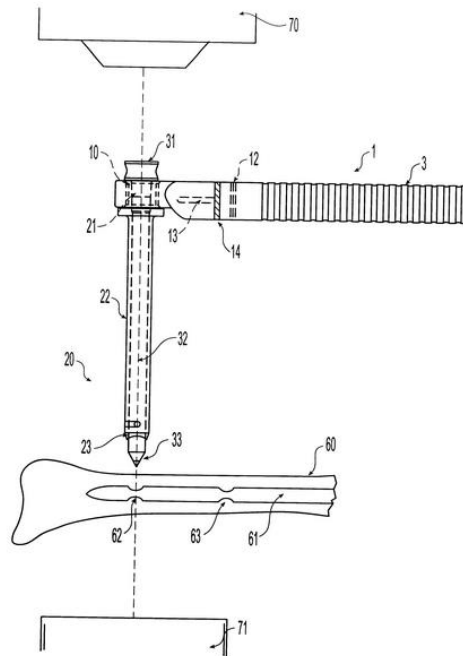

Figure 8: Radiolucent Aiming Guide (Wilson, 2003)

Coaxial laser targeting device

Another type of aiming guide that utilizes X-ray imaging and a surgical tool is a coaxial laser targeting device. This specific device drills transverse bores in bone for placing interlocking screws. The device is comprised of a helium neon laser and a target grid that is made from a plastic disk. The laser and disk are aligned with the X-ray so that they are coaxial with one another. The target grid is aligned so that it is centered on the monitor with the laser beam adjusted so that it is aiming at the correct location for drilling. The laser beam is visible on human skin and exposed bone. Once

the laser target is on the body, the surgeon can align the drill with the point. Keeping the beam on the back of the drill, the surgeon can then accurately perform the drilling. For the actual drilling portion of the procedure, X-ray monitoring is not used (Trecha, 2003). Figure 9 shows the general procedure for the device.

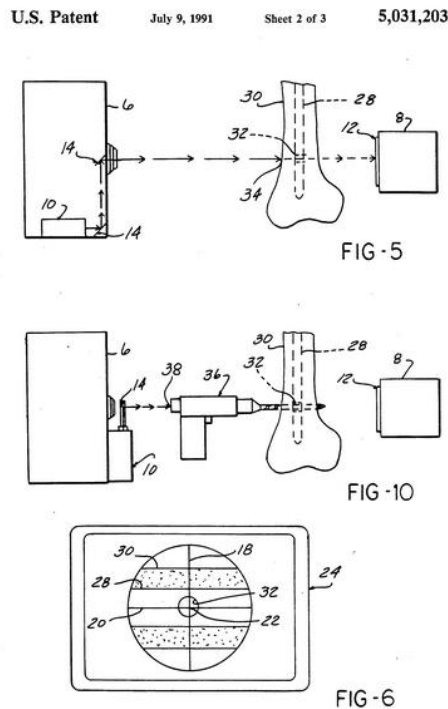

Figure 9: Coaxial laser targeting device (Trecha, 1991).

Fluoroscopic image guide orthopedic surgery system

The fluoroscopic image guide orthopedic surgery system is designed to allow the surgeon to conduct image guided surgery. By using fluoroscopy, surgeons can observe in real-time what they are doing, and can be precise when drilling or inserting a screw with a predetermined trajectory. The system incorporates a C-arm fluoroscope which generates radiographic images in two fields. A three-dimensional optical digitizer is used to determine position through all six degrees of freedom based off of the fluoroscope's X-rays. The fluoroscope translates the images to a computer program, which give exact relative position of the object bone. Light emitting diodes (LED's) are used as

references on the C-arm, the bone, and the drill in order to pinpoint the precise locations of the object bone and drill bit (Barrick, 1998).

The sequence of events required to produce the real time image during surgery starts with the C-arm fluoroscope taking images of the bone at two different views. The images are then processed by the optical digitizer which give real time positions of the bone. The device limits patient exposure to radiation because the X-ray imaging only occurs twice throughout the process and is not on during the surgery. A guide pin can be inserted into the surgical site if needed, as shown in *Figure 10* (Barrick, 1998).

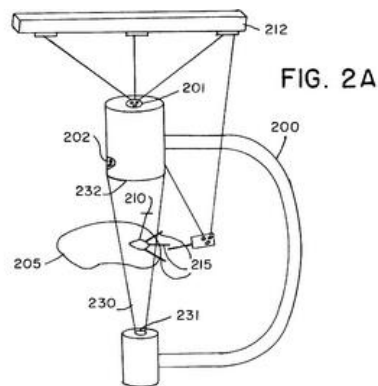

Figure 10: C-arm Fluoroscope (Barrick, 1998)

3.5.2 Mechanical Guidance

Orthopedic tool guide

Although visual tools can prove to be beneficial in locating points intraoperative, certain mechanical devices can assist in achieving the same goal. Mechanical guides also provide the advantage of being less expensive, as they require less advanced technology. An orthopedic tool guide was designed for the use of arthroscopic surgeries, including anterior and posterior cruciate ligament reconstructions. These type of surgeries depend on the angle and position of the hole that

is drilled. This device consists of a tool member, probe, and connecting structure. The connecting structure is comprised of two arms which are hinged together. The tool member is attached to the first arm and the probe is connected to the second arm. The arms can be rotated relative to one another which allows for a series of different planes to be targeted by the apparatus. The arms are curved in shape with the radius of the first arm being smaller than the radius of the second arm. The tool member may be moved along the first arm in order to target a wider area. The probe can be placed into a punctured opening in the body so that it can be introduced into the joint. The tool guide also has serrations at the hollow tube in order to effectively attach to the site of drilling and allow for firm placement when the drill is inserted. The material the tool is made out of is typically stainless steel. In Figure 11 and Figure 12, a human point locating device is used on a knee, and then isolated to show the range of motion that the device is capable of, respectively (Fox, 1988).

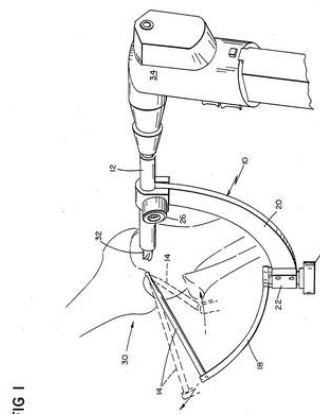

Figure 11: Tool guide in use on joint (Fox, 1988)

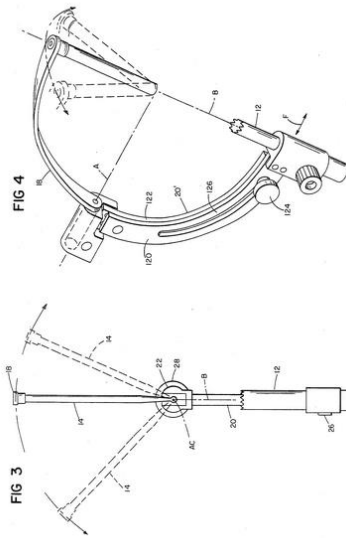

Figure 12: Ranges of motion of tool guide (Fox, 1988)

Extracapsular surgical procedure device

The extracapsular surgical procedure device is used for locating isometric points in the joints of mammals for the use of extracapsular surgical repair. The extracapsular surgical procedure device patent, U.S. patent number US7905924 B2, seen in Figure 13(b), by Ralph Richard White specifically targets canine stifles and the extracapsular repair or stabilization of the cranial cruciate ligament. The device is used to locate two isometric points, one on the tibia and one on the femur. According to the patent holder, the isometric point on the tibia can be found at Gerdy’s Tubercle, shown on Figure 13(a), and on the femur at the lateral femoral condyle. The device is designed to locate and attach itself to each of these locations on the two bones. It is composed of two distal ends which have marking elements. The marking elements or probes are made up of a Steinman pin, K-wire, or other pin which allows them to affix to the bone during the procedure. The attachment sites of the probes are adaptable to accommodate various forms of fixation. The device has a scale that measures the distance between the two distal end probes. The two distal probes are connected to arms which are interconnected to form a pivot joint. There is a locking mechanism on the pivot joint

so that the location of the two probes can be fixed once the isometric points are found (White, 2011). It is a simple design that is used to pinpoint the isometric points based off of the radiographic images that were examined prior to surgery. The device relies on the surgeon to locate the points and it then serves to confirm that the points are isometric by keeping the same distance throughout range of motion. The marks left by the attachment of the device then leave way for the anchor sites to be drilled and suture to be attached. In Figure 13, the device for extracapsular surgical procedure is shown and in Figure 14, the device in use is shown on a canine stifle area (White, 2011).

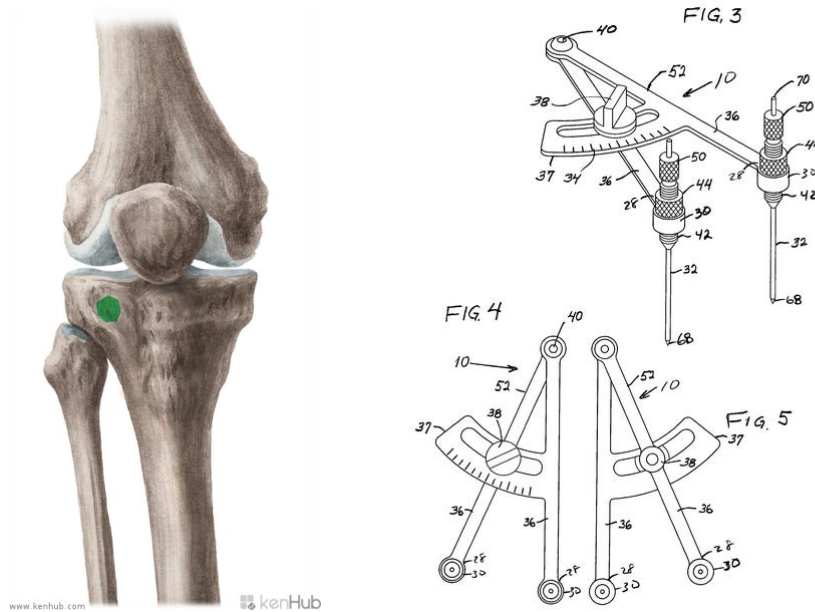

Figure 13: a) Gerdy's Tubercle marked by a green spot (Rubel, Schwarzbard, Leonard, & Cece, 2004) b) Extracapsular surgical procedure device (White, 2011)

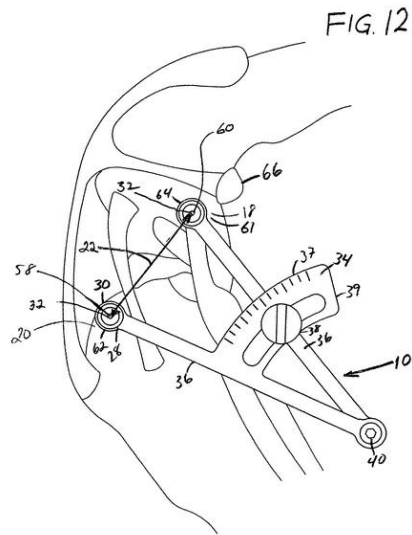

Figure 14: Extracapsular surgical procedure device fixated to bone (White, 2011)

2.6 Gap in Current Research

The major gap that exists in the current research to solve the problem of correct suture attachment placement is the little knowledge regarding where these isometric points are located. This lack of information regarding the points translates into a lack of tools to find them. Without the necessary knowledge and tools, the majority of the CCL repair surgeries are trial and error, causing future issues in the dog's stifle. The testing methods that are conducted in the current research also create a problem in the validity of the results. Testing currently varies among the present research, where cadavers are used with sutures in place, but are not compared to the same cadaver in its healthy stage. Additionally, all current research focuses only on measuring the change in length, or the strain that the suture encounters throughout the range of motion. By combining these factors during future testing, the location of the most anatomic point can be found, and, thus, the functionality of a device that locates these points can be created.

Chapter 3: Project Strategy

3.1 Initial Client Statement

The initial client statement was developed after consulting with the representatives from SECUROS (Andrew Kazanovicz, David Anderson, and Olivia Doane) and the project advisor, Glenn Gaudette.

The initial client statement was

To create an aiming guide to reproducibly locate anatometric zones when placing femoral-tibial fixations on veterinary subjects.

3.2 Objectives

To meet the goal of the creation of an aiming guide, a list of objectives was created. The device must be accurate, safe, reusable, universal, user friendly, and ergonomic and cost efficient.

3.2.1 Accuracy and Precision

The device must be able to accurately, and precisely, identify anatometric points within surgery. Secondary to this objective, the attachment of the device to the stifle component must be stable enough to stay in the precise location as long as the surgeon needs. This should also keep the surgeries consistent and locate the same points across all procedures.

3.2.2 Safety

Dog Safety

The dog's safety is of utmost importance within the device's usage. Some ways to limit damage to the stifle can be achieved by avoiding additional surgical steps so that the dog is not harmed any more than it would have been during the current procedure for CCL lateral suture fixation.

User Safety

This objective also requires that the surgeon is properly educated on the procedure and device usage. The device should not harm the user in any way.

3.2.3 Reusable

The device must be reusable from surgery to surgery so that cost can be limited for the surgeon and also the canine owner. The secondary objectives of durability and the easiness of cleaning with support the main objective of reusability. The device must be durable.

3.2.4 Universal

To limit an excess amount of devices the surgeon needs to have during surgery, the device needs to fit multiple breeds of similar-sized dogs, as well as both the right and left legs on each dog. Adjustability of the device will allow for use across breeds.

3.2.5 User Friendly

When creating a successful device, the end user needs to be considered. To create a user friendly device, the secondary objectives of portability, being intuitive, and succinct training needs to be addressed. If training is required to ensure the device is being used properly, then the training should be relatively easy, but comprehensive. Additionally, it is necessary that the device does not hinder or prolong the surgery more than desired by surgeons.

3.2.6 Ergonomic

With the goal of not disturbing the procedure of the surgery in mind, the device needs to be comfortable, easy to hold, and not cumbersome. When being held, the device must be ergonomic

and comfortably fit the surgeon’s hand. In general terms, the device must not be a nuisance to the surgeon.

3.2.7 Pairwise Comparison Chart

The pairwise comparison chart was completed by the team and the SECUROS advisors based on the knowledge and research of the problem. Each member of the team and SECUROS ranked which objective they felt was most important compared to another objective, then the average for the final pairwise comparison chart was calculated, as shown in Table 1.

Table 1: Pairwise Comparison Chart

	Accuracy	User Friendly	Ergonomic	Universal	Cost	Reusable	Safety	Points
Accuracy	X	0.83	1	1	0.67	0.83	0.33	4.67
User Friendly	0.17	X	0.83	0.33	0.33	0.67	0	2.33
Ergonomic	0	0.17	X	0.17	0	0.33	0	0.67
Universal	0	0.67	0.83	X	0.33	0.33	0	2.17
Cost	0.33	0.67	1	0.67	X	0.67	0	3.33
Reusable	0.17	0.33	0.67	0.67	0.33	X	0	2.17
Safety	0.67	1	1	1	1	1	X	5.67

Ranking (from most important to least important):

1. Safety
2. Accuracy
3. Cost
4. User Friendly
5. Reusable & Universal
6. Ergonomic

3.3 Constraints

3.3.1 Accurately locate points to nearest $\pm 2\text{mm}$

Several constraints are necessary to ensure the effectiveness of the point guide's design. In order for the device created to fully address the main objective of accuracy, the device must accurately locate the anatomic points within $\pm 2\text{mm}$. This will allow for the surgeries to be repeatedly successful. Because the regions of isometry themselves are so crucial to the success of the stifle regaining full function, the tolerance for error is small, ensuring the correct placement of the sutures.

3.3.2 Size of device

As stated previously, because the device is meant for intraoperative use, it must be small enough to transport. Because of the fast-paced operating room environment, the device needs to be easily accessible to the surgeon and having a portable device would ease its use. Additionally, the device size should allow the aiming guide to be ergonomic to the surgeon. The device must also be small enough to fit within the autoclave in order to facilitate sterilization and ensure reusability.

3.3.3 Cost

Veterinary surgeries are much less common than human surgeries, which presents a design constraint on the tools used. This device must cost less than \$1800 in order to be worthwhile for the surgeons to not lose money on the surgeries. An average CCL surgery costs between \$500 and \$2,500 (Colorado State Veterinary Hospital). Since this device will be able to be cleaned and used for numerous surgeries, an initial cost below \$1800 should prove profitable after just a few surgeries.

3.3.4 Training time

Lastly, the device must be accompanied by instructional or succinct tutorial materials to ensure proper device use. The device itself should be intuitive, but the additional material will provide answers to any potential confusion on placement or drilling techniques. This training time should be no more than one day of learning and practice.

3.3.5 Testing

For the testing of the devices, time and resources are limited. The testing is restricted to cadavers, and must be completed within one academic year. A prospective *in vivo* study of the performance of the sutures attached at the anatomic points discovered in this research will not be possible.

3.4 Functions

After carefully considering the objectives and constraints, a list of three functions the device must perform was developed:

1. Attach to the canine stifle in a way that is minimally invasive and does not cause unnecessary harm to the animal.
2. Accurately, and precisely locate the anatomic regions intraoperative without disturbing the general procedure of the surgery.
3. Guide the surgeon to drill the bone at the proper points

3.5 Revised Client Statement

After identifying the objectives, constraints, and functions, the goals of the project were more clearly defined. The refined version of the initial client statement was:

Create an intraoperative aiming guide to reproducibly locate the most isometric set of points in the canine stifle when fixating the suture in a Lateral Suture Stabilization surgery on mid-sized canine subjects, and develop a model which will aid SECUROS in explaining the problem and the need for the device.

3.6 Strategy for Finding the Most Isometric Points

Before a device that intraoperatively locates the most isometric points on the canine stifle was created, the points needed to be identified. Since there is little research on the matter, *in-vitro* cadaver testing with 9 canine stifles was conducted. Figure 15 below displays the location of the most anatomometric points between the femur and the tibia, while Figure 16 shows the measurements required to precisely locate the selected points. The details on the tests conducted and results are located in the full research paper in Appendix A.

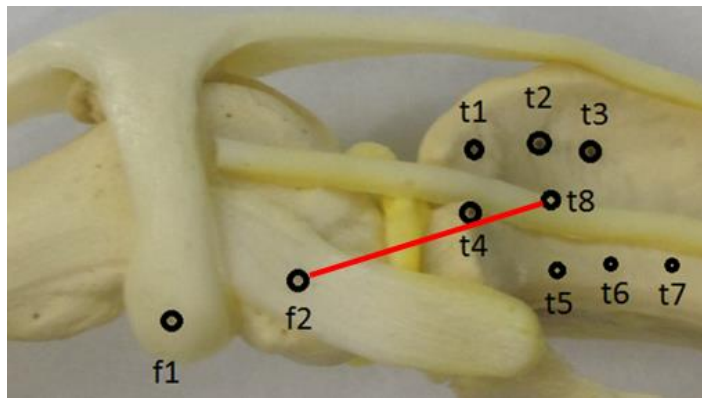

Figure 15: Most anatomometric points, represented by the femoral point F2 and the tibial point T8

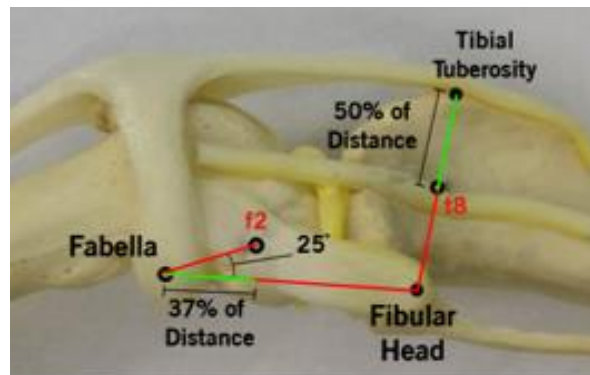

Figure 16: Precise measurements to the locations of the most anatomometric points

Chapter 4: Alternative Designs

To conceptualize these alternative designs we used information from reputable research papers; input from our sponsor, SECUROS; and input from veterinary surgeons Dr. Fred Pike, Dr. William Faircloth, and Dr. Sean Murphy, who all have many years of experience in the field.

4.1 Needs analysis

There are several options to repair CCL ruptures in canines. Each has its own advantages and disadvantages. In particular, LSS is the simplest solution to this problem. The procedure doesn't require a lot of experience, so it can be concluded that this technique is the most available amongst veterinary surgeons and general practitioners. Additionally, SECUROS has a selection of products that apply to LSS. Before selecting a final prototype design, the team brainstormed and developed three conceptual ideas.

4.2 Conceptual Design #1

To identify the most anatomic points on the femur and the tibia, one concept was to have two devices – each one specific to the femur or tibia. The femoral assistive drill guide would loop around the caudal side of the fabella, then extended to the desired length depending on the size of the dog. The extending portion of the device would have numbers engraved on it so that the user could pull the extension out to a specific length. A set-screw would connect the loop to the extension piece so that the correct positioning could be locked in place. Accompanying the device would be a chart defining what number to set the extension to for different sized dogs. At the end of the extension is a hole specific to the size of the drill that is used to attach the anchor for the surgeon to drill through. The tibial device would operate in a similar way, with the alteration being a rod placed in the long digital extensor tendon groove to stabilize the device. The extension on this device would also be adjustable to adapt to different sized dogs with a hole at the end of the extension to drill the tunnel through the tibia. Both pieces can be seen below in Figure 17.

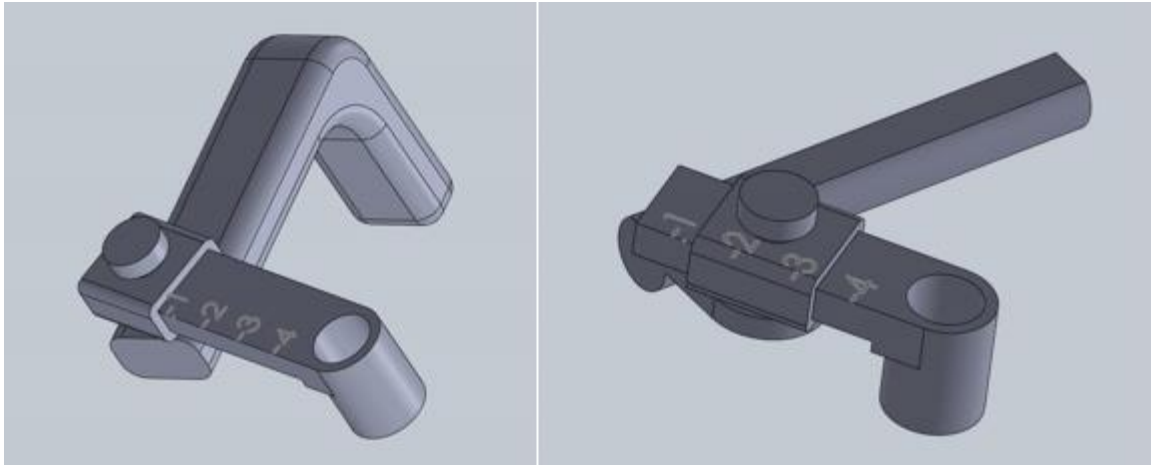

Figure 17: Left: Femur Piece; Right: Tibia Piece

The benefits to this device would be that two devices could encompass a specific bone for a better fit, providing more accuracy for the surgeon. The limitations were that there were two separate devices that needed to be handled, which can cause concerns for surgeons working without an assistant. Having two separate devices for the two separate bones helped with accuracy, but added complication for the surgeon in having a more complex system.

4.3 Conceptual Design #2

A projector system was developed to cast an image over the bone to identify the femoral and tibial points that needed to be drilled during surgery. The idea was to have an x-ray of the deficient stifle scanned onto a computer program similar to Photoshop, so that a SECUROS employee could outline the bone in white, then black out the rest of the x-ray image. From there, a white circle would be placed precisely where the most anatomic point was on both the femur and tibia. The x-ray would then be used during surgery with a light source to align over the leg on the operating table. The image would then be adjusted so that the bone outline was clear and exactly overlaying the canine stifle. The light projected from the white circle would show the surgeon precisely where to attach the anchor or drill the tunnel during surgery.

A few design ideas were generated for the fixture that would hold the light source needed for the projection. The first was the use of a handheld light. The x-ray would be made into a small transparency that would slide over and attach on the light. With one hand the surgeon would hold the light over the canine's leg and drill with the other hand. The limitation with this design was that it did not ensure that the light would be positioned directly above the stifle and the surgeon would also have needed to hold the light steady while drilling with the other hand. The benefit of this device was that it was handheld and did not take up much space in the operating room.

The second method of holding the transparency and light source was to have a stand with four adjustable legs and a light positioned directly vertical to the ground. A simple flashlight could be used as the light source and could be placed in the holder at the center of all the legs. At the bottom of the light holder was a slit to slide the transparency through. The benefit to this design is that the light does not need to be held by the surgeon or assistant, and would ensure that it is shining perpendicular to the stifle. Additionally, with adjustable legs, the distance the light is from the stifle could be adjusted to enlarge or shrink the projected image while keeping the light at the same angle. The drawbacks are that the legs would need to be positioned on the operating table, causing less room for the surgeon to work. This device also has potential to be very large, taking up more room in the veterinary office. Lastly, the position of the projected image can only be altered vertically, resulting in the leg needing to be positioned just right on the table without getting in the way of the devices legs.

The last iteration of ways to hold the light source involved a stand that held an adjustable plane over the operating table. The stand would be positioned next to the operating table at any side to stay out of the surgeon's way. The plane that extended over the operating table would be adjustable vertically along the stand to adjust the size of the projected image. The light source

would be placed in the holder inside of the plane and able to be positioned in any direction to move directly above the stifle. Under the light source holder would be a slot for the transparency to lie. The limitations with this device are that it is very large and will take up room within the operating room. There are many benefits that are associated with it, however. The plane suspended over the table allows the light to be positioned directly above the stifle, while allowing room for the surgeon to operate underneath. The device's ability to move in all planes also allows the surgeon to position the light above the leg, instead of having to position the leg under the light. Figure 18 below shows the design iterations of the latter two designs of the projector concept.

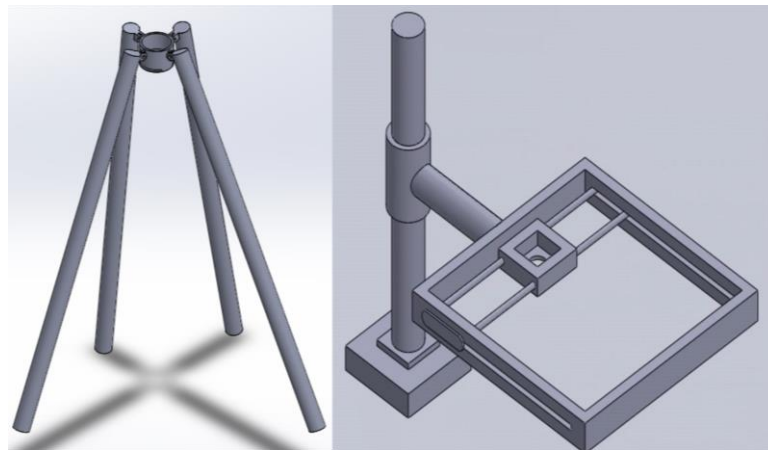

Figure 18: Two projector design iterations

The general idea of the projector system has its own drawbacks in addition to the specific design limitations. Sending x-rays to SECUIROS would require surgeons to have to take x-rays in advance, then wait until the transparency sheets return before the surgery can be completed. The light also causes complications in an operating room. With surgeries requiring as much light as possible, it is difficult to diminish light in order to see the projected image over the bone. Much of the bone is also covered by muscle and fur, so positioning the outline of the bone correctly above the stifle has great potential for human error. Lastly, focusing the light may be troublesome for surgeons

to get a crisp image to know where to drill. There are a few benefits that accompany this overall concept. This method requires very little, if any, contact with the actual dog, making biocompatibility a very small concern. The customized x-rays would also provide for very specific calculations of the most anatomic points, allowing this method to be used on any type of dog, adding to the universality of the device.

4.4 Conceptual Design #3

A four-bar linkage system was developed to span the entire stifle, locating both the points on the femur and tibia. Different iterations of each aspect of this concept were explored. The major qualities considered were fixation, bars or linkages, shape, adaptability, and drilling holes. By finding the optimal aspect of each of these categories, a device would be made that fit with the anatomy of the stifle, located the anatomic points, and allowed for accurate drilling.

First, the method of fixation of the device to the bone was developed. One option was to have a simple pin that would be placed on an identifiable landmark on the bone. This option could slip if not on a flat surface but could allow for great precision due to the small surface area on the tip of the pin. Secondly, a clamp method was created that acted as a vice around the sides of the bone and would be coated with a rough surface to prevent slipping. The drawback to this is that the entire bone may not be exposed to be able to clamp around during surgery, but the advantage was that the rough surface overcame the slipping issue present with the pin method.

The shape of the bars was also considered in order for the device to conform to the anatomy of the stifle. Although all of the four bars may not be the same shape, the different options were developed. The first would be straight bars, and different lengths of links would account for the varying terrain of the bone. Next, a curved bar was designed that would adapt to the anatomy of the bone. An angled bar was the next option that incorporated a slant to adapt to different

elevations on the bone by having the sloped region of the bar match the slope of the bone. Lastly, a form fit bar was designed where the terrain of the bone would be matched by a thicker bar. All four iterations can be seen in Figure 19.

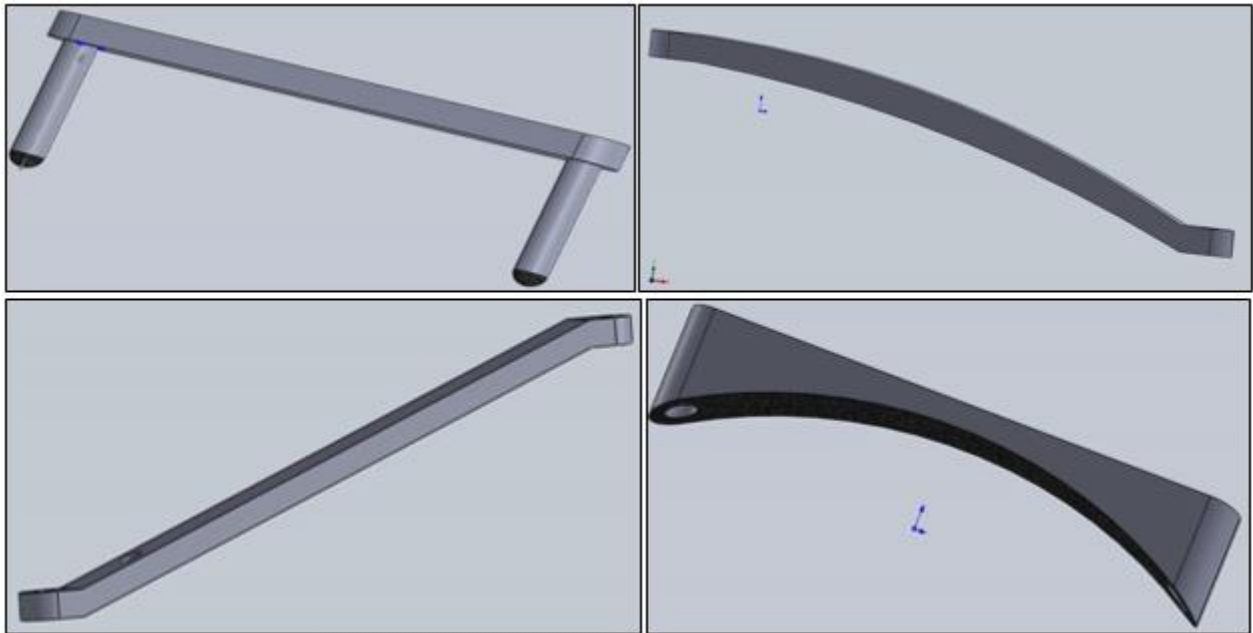

Figure 19: (Clock-wise from Top-Left) Straight, Curved, Angled, and Form Fit Bar Iterations

Adaptability was the next category that was incorporated. First, a bar was developed that had multiple holes along the bar to provide for many different drill guide options using the same device. Next was different sized bars to be sent with a guide for what size dogs they are best used on. After that, an adjustable hole guide was created that had an attachment wrapped around the bar that could slide up and down the hollow bar to be positioned at the optimal location.

Lastly, the different methods for drill guides were explored. Methods were created to accommodate for straight, perpendicular drills onto the bone as well as angled holes. The angled holes would allow for the surgeon to position the tunnel and the anchor at the angle that will secure the suture best. In addition to the angle of the cut, the depth was also considered with a stopper

placed on top of a drill guide hole to physically stop the drill from penetrating any further into the bone than necessary. A basic four bar linkage concept can be seen in Figure 20.

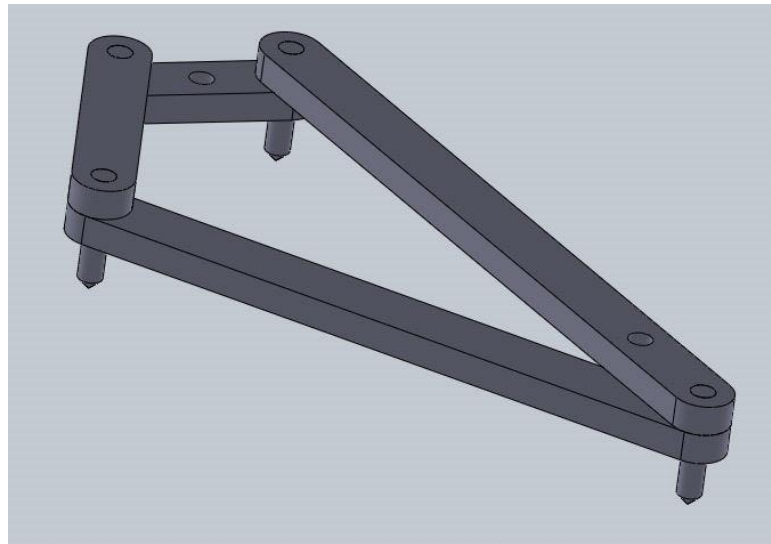

Figure 20: Basic Four Bar Linkage Conceptual Design

4.5 Feasibility and Design Selection:

The first conceptual idea was discarded after discussions with SECUROS. With the idea of limiting human error in mind, it was agreed that two separate, adjustable, small pieces would increase human error, or cause frustration to the surgeon. The focus then shifted to the last two conceptual ideas.

A rough prototype of the projector approach was created by attaching a small LED to an adjustable camera tripod, and the transparencies were prototyped by printing outlines of a canine femur and tibia. Figure 21: Projector Design Idea Proof of Concept below shows the prototype of our projector approach. The clarity of the image was heavily affected by the room's lighting, especially when the room had multiple sources of light. Focusing the image also proved to be a challenge. When presented with these issues, a veterinary surgeon was consulted about the feasibility of this device. This surgeon then clarified that most veterinary operating rooms are

illuminated through the natural light that comes through the windows, which would provide a huge obstacle to the projector idea, which was found to work best with a single, focused source of light. Not only would the natural light create multiple projections, it would nullify all efforts to focus and sharpen the image. Because of these factors, the projector approach was deemed impractical and the idea was abandoned. Thus, a four bar linkage system was developed.



Figure 21: Projector Design Idea Proof of Concept

The device works by lining the pins connected to bars to be placed at obvious landmarks on the stifle, then using a hole on the bar as the drill guide. This concept was the most ideal due to its simplicity, which minimized human error, was easy to manufacture and clean, and did not require additional assistance from technicians during the surgery. With all efforts directed towards the four-bar linkage concept, many different designs were created: a flat bar, a sloped bar, and a curved bar.

4.6 Design Functions:

After selecting the four-bar linkage style device, several functions for the device were determined. The device had to locate anatomical points, fixate to the stifle in some way, assist the guidance of the drilling procedure, be made out of a proper material, adjust to the geometry of the stifle, and be able to accommodate various breeds of canines. Table 2: Function Means Chart below shows a function means chart was created in order to outline the potential design feature that could accomplish these functions.

Table 2: Function Means Chart

<i>Function Means</i>	1	2	3	4
<i>Locates Isometric Points</i>	Identify based off of key landmarks			
<i>Fixes to Bone or Muscle Tissue</i>	Screw	Clamp	Abrasive Ball	Abrasive Concave Peg
<i>Assist Surgical Drill</i>	Hole	Tube		
<i>Material for Surgical Device</i>	Aluminum	Stainless Steel	Titanium	
<i>Adjust to Shape of Canine Stifle</i>	Straight Bars	Angled Bars	Curved Bars	Form Fit Bars
<i>Accommodate various breeds of canine</i>	Different individually sized devices	Slide adjusting linkages	Interchangeable linkages	

After several design iterations, a design was selected to meet the functions needed for the device. The device would locate and be oriented around the anatomical suture attachment sites through key landmarks on the stifle. These landmarks include the tibial tuberosity, fibular head, and fabella, all of which are well known landmarks and easily identifiable during surgery. It was determined that the device would fixate to the bone by resting the links on the landmarks of the stifle. The device would assist the drilling process during surgery through holes in the bar placed over the anatomical points. The material chosen for the device was 316 stainless steel, which is commonly used in surgical tools. Various link sizes would be used to help the device adjust to the geometry of the stifle. Lastly it was determined that the device would be scaled to several different sizes in order to accommodate various canine sizes and breeds of canines.

All of the different designs for the four-bar linkage were modeled in SolidWorks, and placed on a rough model of the stifle. The stifle model was created in SolidWorks by taking slices of a Sawbone model of a Labrador's knee, creating outlines of those slices on separate planes, and connecting those outlines through 3D sketches. Figure 22 shows our stifle model with the curved linkage.

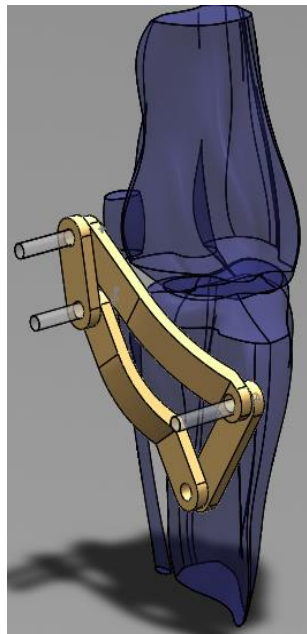

Figure 22: 3-D Model of the Stifle with Curved Linkage

4.7 Optimization and Decisions

Several design iterations were performed for the four-bar linkage device, which allowed for the device to go from a conceptual design to a functional prototype that met all the functions and objectives desired for the device. The iterations were modeled in Solidworks and 3-D printed in ABS plastic. This allowed for the prototypes to be tested on cadaver samples as well as given to veterinary surgeons so that they could offer the best feedback possible. Each iteration helped to further reach the aims of the functions and objectives. Manufacturability of the device was also taken into consideration when assessing prototypes.

The first design iteration was to have a four-bar linkage on both the femur and tibia individually. This soon led to second iteration where the four-bar linkage spanned across the whole stifle. In the third iteration, the links or pins were positioned on specific landmarks on the stifle that were visible in surgery. These landmarks, as mentioned prior, are the tibial tuberosity, the fabella, and the fibular head. The fourth iteration was made to help the device conform to stifle geometry and terrain. Curved bars were prototyped as well as links of different lengths. The links were designed as part of the top-resting bars and allowed for a level elevation on the surface of the four-bar linkage. In the fifth iteration, manufacturability of the device was taken into more detailed consideration. This led the iteration to have straight bars instead of curved bars. Curved bars would have required increased machining time and high material waste. Straight bars along with varied link heights were determined to be the optimal design for adjusting to canine stifle anatomy. Straight holes for drill guidance were also the most ideal option in comparison to angle drill holes because of the ease and accuracy of the manufacturing process. It was also determined that the links be separate from the bars. Having the links and bars be connected and machined out of one solid block of metal would lead to high material waste and added machining time. The last accommodation included in the fifth iteration was the addition of extra drill holes so that one linkage device could be used on both a left and right sided stifle. In the sixth and final iteration of the device prototype, a handle was added to improve stability of the device during surgery. Various device iterations can be seen in Figure 23. The device was also scaled to five different sizes in order to accommodate various sizes and breeds of canines. This method of scaling proved to be most ideal in comparison to bars that could slide and adjust to various sizes. Finally labels were added to the device to make it more intuitive to understand where the links should be positioned, as well as assist in the assembly and correct selection of device size.

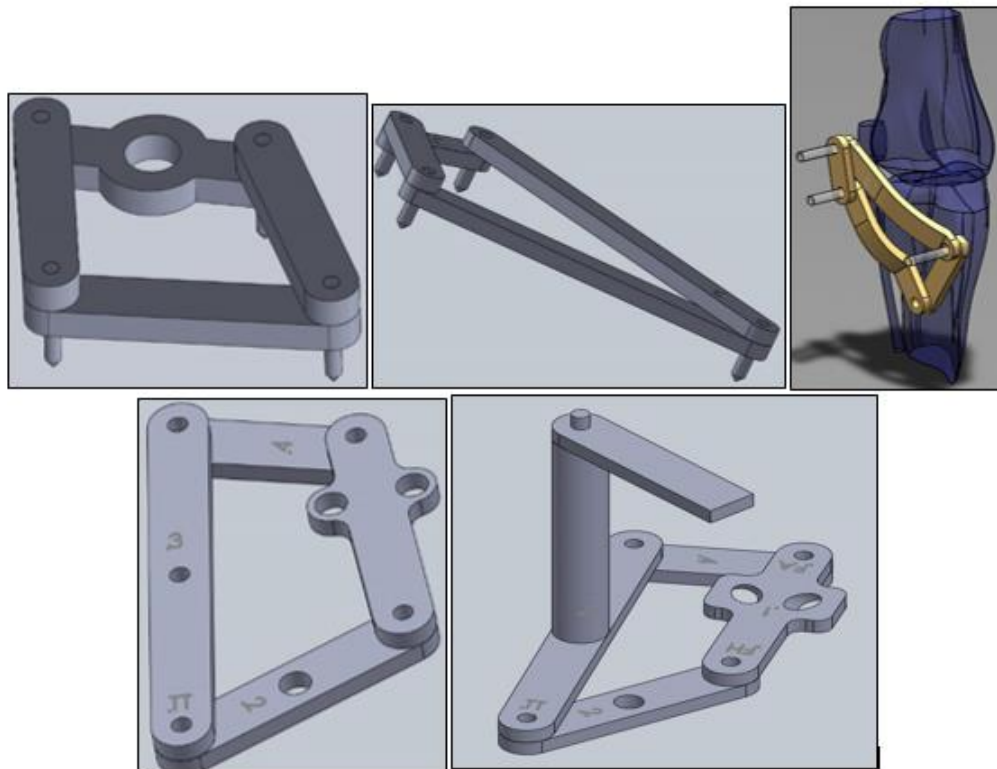

Figure 23: Four Bar Linkage Design Iterations

Several of these design iterations were driven from feedback received from veterinary surgeons from around the country and engineers at SECUROS. These parties helped to confirm that the three landmarks the four bar linkage would rest upon to locate the anatomometric points were common knowledge for veterinarian surgeons and would be easy to locate during the surgery. Surgeons also recommended the addition of further stabilization of the device through the addition of a handle.

4.8 Design specifications:

To accommodate for the different sizes resulted from biological variability, we scaled the device into five different sizes. These size ranges were all obtained from the cadavers used for anatomometric point testing. The distance between two landmarks (tibial tuberosity and fibular head; Figure 24(a)) on the cadaver stifle dictates the size of the chosen device. The diameter of the drill

holes is 5mm, which is based off of the size of the drill bits and bone anchors typically used in the surgery in mid-sized dogs. Dimensions of one of the bars of our middle range linkage can be seen in Figure 24(b) below. All dimensions of all bars can be found in Appendix G: Dimension Table.

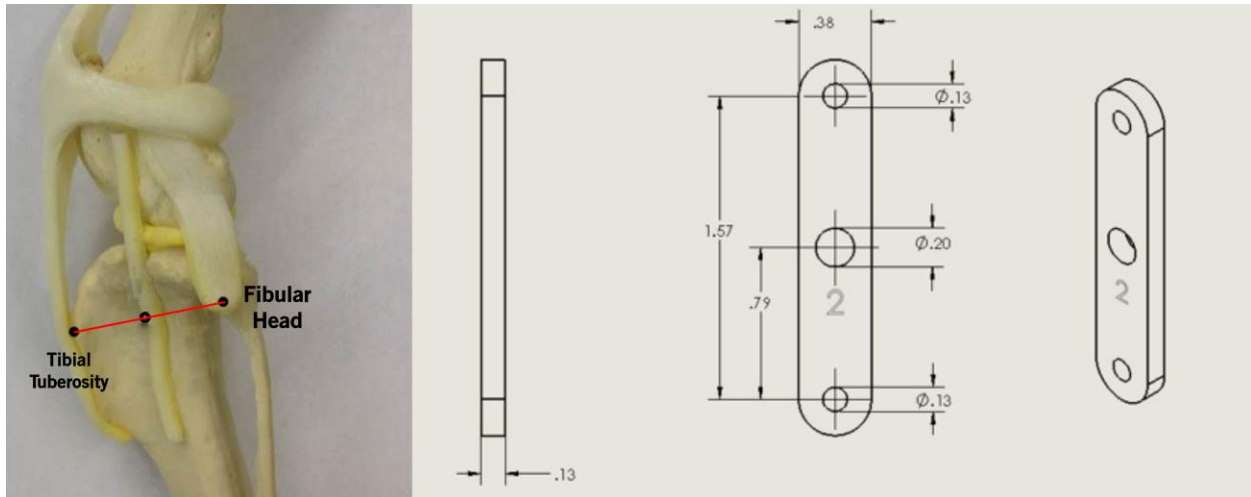

Figure 24: (a) Landmarks (b) Dimensions of the Bottom Bar

The material chosen was 316 stainless steel, as it is an accessible, and durable material. Many drill guides in the market, both for medical and regular use, are made of stainless steel. Although the device itself is not meant to be implantable, it is still important to note that stainless steel has shown great biocompatibility, minimizing the risk of the surgery.

Chapter 5: Design Verification

Once the final Anatometric Point Guide device was chosen, a rapid prototype model was brought to two surgeons with a questionnaire to validate that the device fit their desired characteristics.

5.1 Questionnaire Development

To quantify the success of the device, a pass-fail questionnaire was generated to evaluate how well the device conforms to the original objectives. The objectives of interest were user friendliness and ease of use, reusability, accuracy, and universality. In addition to device specific questions, space was available for qualitative responses regarding the surgeon's particular method for performing this surgery and their current understanding of the problem presented. These questions were created to facilitate future development of marking tools by gaining a better understanding of the present knowledge from professionals in the field. The full questionnaire can be found in Appendix B.

5.2 Surgeon Validation

Two surgeons were consulted using this questionnaire – both of them were also given a prototype of the anatometric point guide. To get variance between the data, geographic location and credentials were considered. One surgeon, Dr. Sean Murphy, is a board certified practicing veterinarian from Boise, Idaho while the other surgeon, Dr. William Faircloth, is a general practice veterinarian from Westfield, Massachusetts. Both surgeons were briefed on the goals and objectives of the project then presented with the device and asked to answer the questionnaire. The completed questionnaire for Dr. Faircloth and Dr. Murphy can be found in Appendices Appendix C and Appendix D, respectively.

Overall, both surgeons had positive feedback and believed that the device addressed the major problem within the field of CCL LSS repair. A summary of the relevant results are shown in Table 3.

Table 3: Summary of Surgeon Responses

<i>Question</i>	<i>Percent of Surgeons that Answered “Yes”</i>
The device is intuitive to use	100%
The device attaches to the landmarks properly	100%
The device is easy to use while drilling	100%*
The device is easy to assemble, disassemble, and clean	100%
I would pay for and use this device for CCL repair	100%

The affirmative responses to the questions asked in Table 3 show that the device addressed all original objectives. The asterisk that accompanies the question “The device is easy to use while drilling” is there because both surgeons saw a prototype of the design without a handle. Both suggested that the addition of a handle would enhance the ease of use of the device, which is why it was incorporated into the final design upon the surgeon’s request. The last question in Table 3 speaks to the success and need for this device. This question confirmed that both surgeons would pay for and use this device, meaning that they would alter their current surgical procedure to accommodate anatomic point research and use of the device into their new practice. This statement was made after the surgeon was made aware of the expected device price range. These results validated that the device met the needs of the problem and would be accepted by surgeons in the field.

Chapter 6: Discussion

The results of the pass-fail questionnaire emphasized the need for the device. Although these veterinarians have been practicing for many years, both mentioned they would pay for use the device, abandoning their current practice. This statement also shows that there is a true market for this device - a market that has been waiting for quite a while for a development of this kind. The device was presented with a price range of between \$600 and \$1000, which was decided by considering the price of the surgery and products that also aid in the surgery. The price was validated by SECUROS.

6.1 Limitations

The testing performed to locate the anatomical points had some limitations that are discussed in Appendix A. Once the device was completed, the team decided to pursue a patent, and this process limited the amount of surgeons contacted for device feedback. Another limitation is that the final prototype of the device could not be tested during an actual LSS surgery. In future experimentation of the device, the team recommends a prospective study of the ability of sutures placed with this device to prevent unwanted translation in the stifle of live subjects throughout long periods of time. These limitations, however, only present obstacles that can be overcome with more time and financial resources. The limitations do not directly impact the validation at this stage of the device development.

6.2 Impact

A portion of the project focused on locating the anatomical points. As previously mentioned, there is limited data on where surgeons should attach the sutures on the femur and tibia of a canine stifle during LSS. This project is unique, not only because of the creation of a device that accurately and precisely locates anatomical points during a surgery, but because research was conducted that located the points that are the most optimal for the surgery. Two clinically relevant tests were

performed on cadaver stifles to find the most anatomical set of points. The full findings of these tests can be found in Appendix A.

There is an active patent of a device that has a similar goal, but a completely different method. The anatomical points the device created in this project locates have been proven to be the specific combination of points that are isometric and prevent translation of the stifle. Additionally, the anatomical point guide created in this project attaches to three different landmarks of the bone and references the anatomical points from them. The only other device used for this function, which was referenced in Chapter 3, only references one landmark. For these reasons this anatomical drill guide can adapt to small biological variations much better than the currently available drill guide. Additionally, the way this new device is designed allows for simple manufacturing and can be scaled to fit smaller and larger canine breeds. With further research, the point guide could even be adapted for use with different species of quadrupeds.

This device has the potential to have a significant economic impact for pet owners. As mentioned in the background section, LSS currently has a high complication rate. This means repeated visits to the veterinarian and increased expenses for pet owners. This device can lower the complication rate of LSS, resulting in a lower total price for veterinarian's clients. Additionally, this device presents a significant economic opportunity for SECUROS; it is a groundbreaking device, and a direct line into this \$1.3 billion dollar industry (Wilke et al., 2005). Being the first company to introduce an anatomical point guide into the market provides a first mover advantage for the project's sponsor, SECUROS.

The device has very little negative impact on the natural environment. The device is made out of medical grade stainless steel so it is reusable, which eliminates one-time-use devices being disposed into the environment. As long as the device is disposed of in a proper manner once it

reaches the end of its life cycle, it will not have negative impacts on the natural environment. The device's positive impacts on the natural environment are also minimal considering that it will be used to improve the canine veterinary industry.

Although this device has no effect on politics, it does hold a huge impact for society, and its economy. Trust is a critical factor in a strongly functioning society. Trust is especially important when it comes to the medical industry. People need to know that they can trust doctors and surgeons to perform their jobs to the best of their abilities, from giving a correct diagnosis to performing a flawless surgery. The canine medical industry is no different. The anatomic point guide will help to establish more trust in a very common procedure that makes up a \$1.3 billion dollar industry. This will reflect well on veterinary practices and allow people to continue to rely on medical professionals to aid in restoring the health of their canines.

The anatomic point guide has the ability to influence the global market. Since veterinary surgery is practiced world-wide, the device could be brought into markets around the world. Its being affordable will also help to insure its global impact. The cost of the device was taken into consideration when choosing a final design. The device is made out of fairly inexpensive metal and is easy to produce. Other cultures may not support paying a lot of money for ensuring the health of pets. This device could help ensure that people around the world pay less for the repair of their canines' CCL.

Since the drill guide can result in fewer visits to the veterinarian, it provides a higher level of comfort for the common pet owner. It can be frustrating to place trust in a veterinarian, only to see the repair fail shortly after surgery. Rupture of the CCL is very prevalent, and considering that approximately 37% of all American households own dogs as pets, it affects a large amount of people (American Veterinary Medical Association, 2012). From an ethical standpoint, the device helps to

improve the ethical decision to perform the LSS surgery on canines, knowing that the device will improve the success of the procedure.

The anatomic point guide will ensure the improved health and safety of canines everywhere. Healthier canines will also help to improve the health of their human owners. The stress and anxiety of the canine owner associated with inability of the canine to move without pain due to a rupture CCL can be very taxing. This device will help to reduce such stress and allow for healthier dogs and improved mental health of their owners.

Manufacturability played a big role when deciding on a final device. It was a high priority to create a device that could be built inexpensively, with ease, and with low waste. The device was machined out of medical grade stainless steel. This material, although harder than other metals such as aluminum, has very little wear on drill bits which will save in costs and time in the long run. The process for machining this device involves creating a jig in order to profile the shape of the bar. Making a jig for each bar adds time to the machining process, but in an operation setting, the jigs could be reused every time a device is produced, significantly reducing the time needed for machining. The current design of the bars allows for very minimal material waste, which aids the cost of manufacturing as well as time needed to manufacture.

Creating a device that was reusable directly limits the carbon footprint of the average veterinary clinic. The device is manufactured in a way which reduces material waste as well. Overall the sustainability of the device is very high because of the fact that the amount of material waste associated with the device is low and had been reduced significantly through design iterations.

Chapter 7: Final Design

Based on the results and modifications from the surgeon and device accuracy validation tests, a final Anatometric Point Guide device was determined. The device was based off of research which discovered the anatometric points. This research involved preliminary testing of measuring various femoral-tibial point combinations, cyclic mechanical testing to determine the suture strain throughout the range of motion, and a tibial translation test which mimicked the clinical CCL rupture diagnostic test by measuring the maximum amount of force required to displace the femur caudally off the tibia. The point combination that best prevented the tibial translation while staying relatively isometric throughout the range of motion was selected. The Anatometric Point Guide device was based off of a four-bar linkage design where three of the pins on the linkage were placed at major stifle landmarks, lining up the holes on the device over the anatometric points for drill guidance. To accommodate for the variation in stifle anatomy of different size and breeds of canines, the device was scaled to five different sizes. To select the correct scaled version of the device intraoperatively, a surgeon would measure the distance between the fibular head and the point at which the patellar tendon attaches to the tibial tuberosity then select the device that this measurement is within range of. To address the user friendliness of this device, these scale ranges are engraved on the bottom side of the device for surgeons to ensure they have the correct size. In addition to the scale range engravings, there are also engravings on the top side of each device bar. The first group of markings identify which landmark each pin attaches to. The second group of markings are a number one through four and are located in the middle of each bar. These numbers inform the surgeon which order the bars are attached in when reassembling the device. These markings present to make the device more intuitive and provide less room for error. The handle present on the device gives the surgeon control of the device without impeding on the space needed to drill through the holes. The marketing brochure and instructional models, located in Appendices Appendix E and Appendix F

respectively, also assist in the correct use of the device. A SolidWorks model of the final design can be seen in Figure 25: Final design of the Anatometric Point Guide.

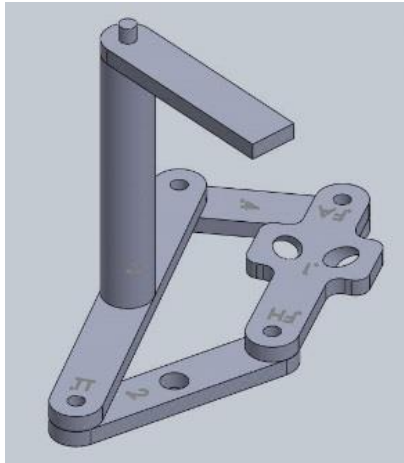

Figure 25: Final design of the Anatometric Point Guide

Chapter 8: Conclusions and Recommendations

Finding the location of the anatomic points allowed the team to design a point guide for canine CCL LSS repair. Initial iterations were improved upon by selecting a four-bar linkage design and adding intuitive assembly instructions, easily manufactured device components, and a handle for stability while drilling. Feedback from surgeons verified that the device was user-friendly, universal, and accurate. These responses confirmed the achievement of the device's objectives. Surgeons also stated they would be willing to purchase the product and abandon current practices to use it, validating the great need for a device of this kind within the current market. Educational materials were developed to demonstrate proper device use. Additional marketing materials were created to outline the need for and value of the team's anatomic point guide.

While the device adequately meets the team's design objectives, the product needs further evaluation and testing which was not feasible in the scope of this study. A provisional patent was filed with the completion of the final prototype and this report. Due to disclosure limitations, the time frame of the patent filing limited the ability to contact a higher number of surgeons. In the future, the device should be used by surgeons during one of the surgeries for more accurate feedback regarding ease of use, accuracy, and universality. Long term success of suture placement and the point guide should also be measured through a prospective study. Data from this study could further validate the device and the anatomic points selected by the team. The device is not currently able to control two variables in the surgery: the angle at which the drill inserts into the bone, and the final suture tension. These factors could cause additional strain to the suture and bone structure. Future research is needed on the impact of the angle of the bone anchor and tibia tunnel. Future iterations of the point guide should consider the drilling angle. Additionally, the links used in the final prototype are made from stock shoulder screws. Upcoming iterations should consider custom links that are manufactured along with the device for improved stability of the linkage.

References

- American Veterinary Medical Association (2012). U.S. Pet Ownership Statistics. Retrieved April 16, 2015.
- Barrick, E. F. (1998). Washington, D.C. Patent No.
- Bergh, M. S., Sullivan, C., Ferrell, C. L., Troy, J., & Budsberg, S. C. (2014). Systematic review of surgical treatments for cranial cruciate ligament disease in dogs. *Journal of the American Animal Hospital Association*, 50(5), 315-321.
- Canapp, S. J. (2007). The Canine Stifle. *Physical Therapy in Small Animals*, 22(4), 195-205. doi: 10.1053/j.ctsap.2007.09.008
- Colorado State University Veterinary Hospital, Treatment options for cranial cruciate ligament injury/disease of the dog knee.
- Fischer, C., Cherres, M., Grevel, V., Oechtering, G., & Bottcher, P. (2010). Effects of Attachment Sites and Joint Angle at the Time of Lateral Suture Fixation on Tension in the Suture for Stabilization of the Cranial Cruciate Ligament Deficient Stifle in Dogs. *The American College of Veterinary Surgeons*, 39, 334-342.
- Fox, J. M. (1988). Washington, D. C. Patent No.
- Hulse, D., Hyman, W., Beale, B., Saunders, B., Peycke, I., & Hosgood, G. (2010). Determination of isometric points for placement of a later suture in treatment of the cranial cruciate ligament deficient stifle. *Veterinary and comparative orthopaedics and traumatology; V.C.O.T.*, 23(3), 163-167.
- Kazanovicz, A. (2014). [MQP 2014- Lateral Suture Stabilization, Anatometric Point Guide Project].
- Muir, P. (2011). *Advances in the canine cranial cruciate ligament* (Vol. 1): John Wiley & Sons.

- Roe, S., Kue, J., & Gemma, J. (2008). Isometry of potential suture attachment sites for the cranial cruciate ligament deficient canine stifle. *Veterinary and Comparative Orthopaedics and Traumatology*, 21(3), 215.
- Rubel, I., Schwarzbard, I., Leonard, A., & Cece, D. (2004). Anatomic Location of the Peroneal Nerve at the Level of the Proximal Aspect of the Tibia: Gerdy's Safe Zone. *The Journal of Bone & Joint Surgery*, 86(8), 1625-1628.
- SECUROS Catalog. In SECUROS (Ed.), (pp. 57).
- Surgeons, A. C. o. V. (2014). Cranial Cruciate Ligament Disease. Retrieved October 15th, 2014, 2014, from <https://www.acvs.org/small-animal/cranial-cruciate-ligament-disease>
- Tonks, C. A., Pozzi, Antonio, Ling, Hang-Yin, Lewis, Daniel D.,. (2009). The Effects of Extra-Articular Suture Tension on Contact Mechanics of the Lateral Compartment of Cadaveric Stifles Treated with the TightRope CCL or Lateral Suure Technique. *Veterinary Sugery*, 39, 343-349. doi: 10.1111/j.1532-950X.2010.00664.x
- Trecha, R. R. (2003). Washington, D. C. Patent No.
- White, R. R. (2011). United States Patent No. Grant.
- Whitehair, J. G., Vasseur, P. B., & Willits, N. H. (1993). Epidemiology of cranial cruciate ligament rupture in dogs. *Journal of the American Veterinary Medical Association*, 203(7), 1016-1019.
- Wilke, V. L., Robinson, D. A., Evans, R. B., Rothschild, M. F., & Conzemius, M. G. (2005). Estimate of the annual economic impact of treatment of cranial cruciate ligament injury in dogs in the United States. *Journal of the American Veterinary Medical Association*, 227(10), 1604-1607.
- Wilson, F. A. (2003). Washington, D. C. Patent No.: M. E. Nadzadi

Appendix A: *Locating Anatomic Points*

In the Canine Stifle for Lateral Suture Placement

Roman Gutierrez, Brittany Rhodes, Aimee St. Germain, Elliott Wiegman
Advisor: Glenn Gaudette, PhD
Department of Biomedical Engineering,
Worcester Polytechnic Institute, Worcester, MA, USA

Abstract— *Tears to the cranial cruciate ligament account for 90% of all canine hind-limb lameness causing stifle injuries. The most common surgical repair method, lateral suture stabilization, has a 25% failure rate. The purpose of this study is to identify the points on the femur and tibia where the suture should be attached that are the most isometric throughout range of motion while minimizing tibial translation to successfully repair the damaged stifle. Cyclic cadaver testing and tibial translation testing were completed on 9 cadaver stifles of mid-sized dogs to evaluate the strain on sutures at various stifle points, and to collect quantitative data of tibial translation. The results of these tests suggested that femoral point f2, and the tibial point t8 are the most anatomic points due to limited strain on the suture during the stifle range of motion and high forces required for tibial translation. This research will give veterinary surgeons the information they need to correctly place sutures in lateral suture stabilization surgeries, potentially decreasing the number of failed repair attempts.*

INTRODUCTION

Cranial Cruciate Ligament Disease (CCLD), the most common hind limb lameness-causing injury in canines, occurs when the Cranial Cruciate Ligament (CCL) is damaged or deteriorated [1]. Pet owners spend \$1.3 billion annually on canine CCL surgeries [2]. While there are many surgical and rehabilitation options for CCLD, the most common is the Lateral Suture Stabilization (LSS) technique [3]. In LSS, a nylon suture stretches between a point on the femur and a point on the tibia to mimic the mechanical functions of the CCL through stabilization of the joint and minimization tibial translation [4]. The CCL prevents tibial translation, which is the translation of the femur across the tibia. Without surgical intervention, anywhere between 40% and 50% of canines with CCL tears will rupture the opposite CCL [5]. This price does not include any possible complications due to failed suture attachments during LSS.

Attachment points of the suture in LSS procedures are vital for proper function and recovery. Ideally, the distance between these two points should remain constant during the range of motion. Incorrect placement results in suture strain, ineffective functionality, ruptured sutures, osteoarthritis, and further stifle damage. Attachment and anchoring points that overstretch the suture do not allow the joint to complete the full range of motion, and often cause suture rupture post-operatively causing further damages the stifle joint [3].

Despite the importance of the attachment points, limited research has been conducted regarding ideal anchor points. While surgeons have basic guidelines for suture attachment sites during surgery, there are no definitive data for points on the bone that allow for an optimal range of motion and stability. Most importantly, the most isometric point

combination that also prevents tibial translation has not been identified. The point combination that addresses both of these factors is identified as the most “anatomic” region.

The aim of this study is to improve the success rate of a specific type of LSS procedure, Extracapsular lateral bone anchor tibial suture fixation, by locating the most ideal attachment and anchoring sites for these type of procedures. Figure 1 shows a general schematic of how the suture is currently placed on the stifle. Extracapsular suture (ES) repair is a type of LSS and lateral bone anchor tibial suture fixation is a type of ES. Attaching sutures to points that remain the same distance apart through the entire range of motion (ROM) and also prevent excessive tibial translation will allow the damaged stifle to have greater stability.

To define these regions, various tests were conducted using saw bones, fluoroscopy videos, and cadavers. The hypothesis is that a set of anatomic points exists which limits tibial translation and exposes a suture to minimal and constant strain. The results of this research will provide surgeons with scientific data supporting the correct anatomic placement for suture attachment.



Figure 1: Extracapsular lateral bone anchor tibial suture fixation schematic [3]

MATERIALS AND METHODS

The preliminary testing involved analyzing fluoroscopy videos and manual tests using a saw bone and a cadaver. Fluoroscopy videos were obtained from a Fluoroscopic Kinematography website by the University of Leipzig in Germany. The videos were separated into frames. Two frames were selected representing two different angles of the stifle motion. In the first frame, the angle between the femur

and the tibia was 135°, and in the second is was 120°. The distal end of the femur, and the proximal end of the tibia were divided into quadrants. Using ImageJ image analysis software, the distance between the centroids for each possible combination of femur-tibia quadrants was measured at both angles. Then the percent change in distance was calculated. Femur-tibia quadrant combinations that had less than 4% change were selected for a second round of measuring.

In this second round, the quadrants were divided into four subsections. All possible combinations of smaller quadrants were measured once again. The pairs with less than 2% distance change between angles were selected as the most isometric points to be further analyzed on a physical saw bone model and cadaver.

The manual testing method calculated the distance between points during a range of motion in a canine stifle saw bone. The saw bone was positioned at angles 40°, 80°, 120° and 160° using a paper protractor to simulate the maximum range of motion a canine may undergo. The various points selected, explained in Table 1 and shown in Figure 2, were based off of the fluoroscopy videos analysis results and anatomic landmarks that can be seen easily by a surgeon during surgery. To get an accurate measurement of the suture length if attached to these points, a string was placed with one end at a femoral landmark point and the other end placed tautly at a tibial point while the saw bone was held tightly at the specific angle. The string was then removed and measured for that distance, then repeated for all femoral-tibial point combinations. These tests were then repeated and averaged for all combinations to minimize human error. The results of the measured distances for each combination were then analyzed using Microsoft Excel.

Table 1: Description of femoral and tibial point locations

Point	Description
f1	Fabella
f2	Under medial collateral ligament, 1.5 cm distal to fabella
t1	Lateral condyle (part of tibial plateau)
t2	Center of tibial tuberosity
t3	1cm prox from center of tibial tub
t4	anterior portion of tibial plateau, almost on proximal portion of tibial tuberosity
t5	1.2 cm distal to lateral condyle (part of tibial plateau), posterior to long digital extensor tendon
t6	2.3 cm distal to lateral condyle (part of tibial plateau), posterior to long digital extensor tendon
t7	2.9 cm distal to lateral condyle (part of tibial plateau), posterior to long digital extensor tendon
t8	0.6 posterior to center of tibial tub
t9	Long digital extensor tendon

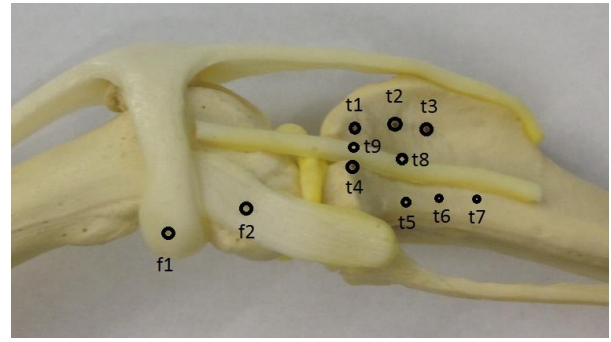

Figure 2: Selected femoral and tibial point locations used during saw bone and cadaver testing

To verify the points found during the saw bone and fluoroscopy video testing, a cadaver was used to complete the same test done on the saw bone. The cadaver was placed at different angles throughout the range of motion then measured using a string. Due to the stiffness of the cadaver, the angles measured were 30°, 70°, 110° and 130°. The same points analyzed with the saw bone were analyzed with the cadaver. The results were again analyzed by Microsoft Excel.

From the preliminary testing, three point combinations were then analyzed mechanically. Testing was performed to quantitatively evaluate the effectiveness of the three femoral-tibial point combinations on prevention of tibial translation. The mechanical test was performed on nine cadavers (three per point combination) and used the Instron 5544, wooden blocks, and various screws to mimic veterinarian's clinical test for tibial translation. This clinical test is conducted by holding the tibia in place with one hand, then applying a force with the other hand that displaces the femur a maximum distance of 25mm in the caudal direction. To mimic this test in a mechanical machine, the caudal side of the tibial tuberosity tibia on a suture-secured cadaver was screwed into a wooden block that was positioned in the bottom grip of the Instron 5544 with the tibia 135 to the grips. An eye screw was secured in the caudal side of the femur between the two condyles. Braided fishing line that can withstand up to 50 pounds was tied to the eye screw and then attached tautly to the top grip. The screw driven machine then pulled the top grip to a displacement of 25mm to mimic the maximum tibial translation that a healthy stifle can withstand, then the maximum force was recorded. This test was completed three times for each cadaver with a new string attached each time. The set-up of this test can be seen in Figure 3.



Figure 3: Test set-up for t translation clinical assessment simulation

Next, the strain that the suture encounters during a full range of motion for the three point combinations being tested was assessed. The same nine cadavers were used as the tibial translation test, all with sutures applied at one of the three point combinations that were being researched. The tibia of the cadaver was secured to a screw action grip of an Instron 5544 mechanical testing machine so that the cranial side of the stifle faced vertically away from the machine. The tibia was slightly angled away from the machine at approximately. A hole was drilled through the proximal end of the femur, then threaded with fishing line. The fishing line was tied tightly around the top load cell of the Instron. The height was adjusted so that the stifle started in the maximum range of motion angle. The set-up of the cadaver in the Instron is shown in Figure 4. From there, the stifle was ran through a cyclic test to simulate a full range of motion while being captured by high definition video. The motion capture was analyzed using Matlab software and the results were compared from all nine tests. The data from the cyclic cadaver testing and tibial translation testing were compiled and analyzed to determine the most optimal femoral-tibial point combination based on strain for isometry and tibial translation prevention.



Figure 4: Cyclic Cadaver

RESULTS

From the preliminary testing, all point combinations were narrowed down to the top three which would move on to be further tested. The top three point combinations were ranked by lowest percent change values collected through both manual testing and fluoroscopy analysis. The following point combinations were selected: f2, t2; f2, t7; and f2, t8, shown in Figure 5, and had maximum percent change values of 1.03, 3.13, and 3.4 respectively.

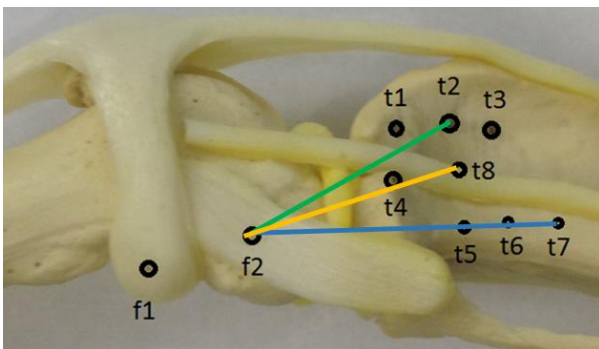

Figure 5: Most isometric points found through preliminary fluoroscopy

The results from the tibial translation test were forces required to cause a 25mm displacement. In order for 25mm of displacement, f2, t2; f2, t7; and f2, t8 had average maximum forces of 80.54, 74.00, and 83.57 respectively, as shown in Figure 6.

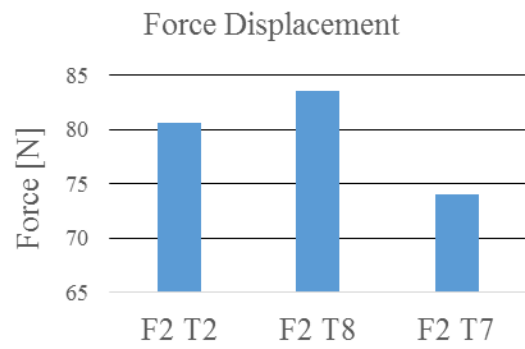

Figure 6: Force Displacement results graph for tibial translation test

The cyclic cadaver testing through a full range of motion resulted in the percent strain on the suture at different points throughout the range of motion. The percent strain and standard deviation for sets f2, t2; f2, t8; and f2, t7 are displayed in Table 2. The information is also displayed in graphical form in Figure 7.

Table 2: Cyclic Cadaver Testing Results

Cyclic Cadaver Testing			
%strain	f2, t2	f2, t7	f2, t8
%strain 80° (flexion)	1.71	1.34	4.39
%strain 50° (flexion)	4.12	1.01	3.11
%strain 80° (extension)	3.40	2.42	4.95
%strain SD	1.23	0.74	0.95

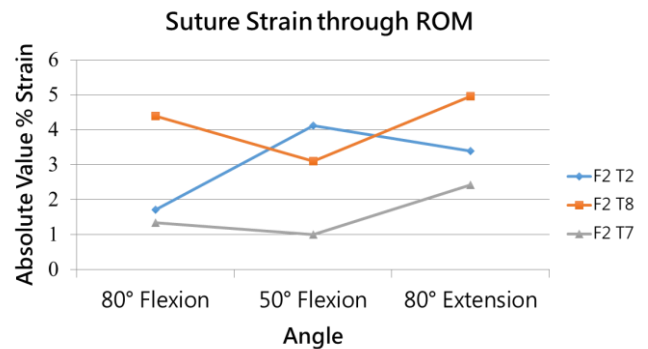

Figure 7: Suture Strain through ROM

DISCUSSION

The combination of f2 and t8 was selected as the most ideal combination of points (Figure 8). The tibial translation test results show that this set of points required the most amount of force to achieve a translation of 25 mm, meaning that it was best at preventing tibial translation. The results of the cyclic testing were not conclusive in determining one set of points as most effective. However, the percent strain values for the combination of f2 and t8 are within the acceptable amount of strain for sutures typically used in this surgery. Failure of these monofilament nylon sutures have been observed to occur at a percent strain of 36 [6]. The maximum value calculated for strain percent between the points f2, t8 was 2.42. Additionally, the strain levels remained relatively constant, showing that a

suture attached at this set of points would remain taught throughout the range of motion.

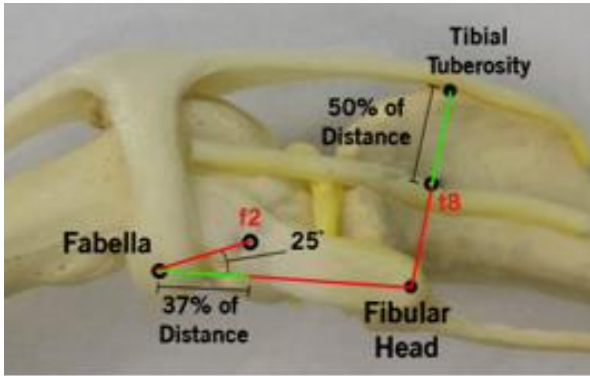

Figure 8: Final Anatomometric Points

The cadavers used in this testing had some limitations. Due to the wide range of potential type of dogs within the midsize category (30-60 pounds), the size varied greatly between the nine samples. These bones were also stripped of all muscle to accommodate for the test methods, which may have an effect on the mechanics of the stifle. Additionally, a larger sample size would have made the sample size more statistically significant. When testing these cadavers, the grips and equipment were not custom to the test, which caused some variance. In the future, custom machined grips for the Instron 5544 would be made to produce more repeatable results for both the tibial translation test and the cyclic cadaver test.

CONCLUSIONS

From this study, a femoral and tibial point were selected that not only take into account isometry throughout the range of motion, but also consider how well the point combination prevents tibial translation. The most anatomometric points found were at f2 and t8. This supports the hypothesis that a set of anatomometric points exists which limits translation and exposes a suture to minimal and constant strain.

With the current amount of LSS failures due to incorrect suture placement, this research is extremely important to the success of future surgeries.

ACKNOWLEDGMENT

The team would like to thank the project advisor Glenn Gaudette, David Anderson and Andrew Kazanovicz from SECUROS, Josh Gershlak, and lab manager Lisa Wall for their kind support, encouragement and guidance throughout the course of this project.

REFERENCES

- [1] D. Tonks, A. Pozzi, H. Ling, D.D. Lewis. (2010). "The Effects of extra-articular suture tension on contact mechanics of the lateral compartment of cadaveric stifles treated with the TightRope CCL or Lateral Suture Technique," *Veterinary Surgery*, 39(3), 343-349.
- [2] V. L. Wilke, D. A. Robinson, R. B. Evans, M. F. Rothschild, and M. G. Conzemius. (2005). "Estimate of the annual economic impact of treatment of cranial cruciate ligament injury in dogs in the United States." *Journal of the American Veterinary Medical Association*, 227(10), 1604-1607.

- [3] Fischer, C., Cherres, M., Grevel, V., Oechtering, G., and Bottcher, P. (2010). "Effects of Attachment Sites and Joint Angle at the Time of Lateral Suture Fixation on Tension in the Suture for Stabilization of the Cranial Cruciate Ligament Deficient Stifle in Dogs." *The American College of Veterinary Surgeons*, 39(3), 334-342.
- [4] S. Roe, J. Kue, and J. Gemma. (2008). "Isometry of potential suture attachment sites for the cranial cruciate ligament deficient canine stifle." *Veterinary and Comparative Orthopedics and Traumatology*, 21(3), 215-2
- [5] D. Anderson and A. Kazanovic (2014). Project Proposal Meeting, Topic: "MQP 2014." Worcester Polytechnic Institute, Worcester, Massachusetts, Oct. 16, 2014
- N. D. Rose, D. Goerke, R. B. Evans, and M. G. Conzemius. (2010). "Mechanical Testing of Orthopedic Suture Materials for Extra-Articular Stabilization of Canine Cruciate Ligament-Deficient Stifles." *Veterinary Surgery*, 41(2), 266-27

Appendix B: Blank Surgeon Questionnaire

Before Testing Device		
Question	Explain	
How do you currently perform the CCL fixation surgery?		
With your current method, how difficult is it to find the most isometric points?		
After Testing Device		
Question	Yes or No	Explain
This device is intuitive to use.		
The directions for using the device are easy to understand and are accurate for proper device usage.		
The device forms to the stifle well.		
This device is easy to hold while drilling.		

This device will be easy to assemble.		
This device will be easy to clean		
I would use this surgical device for CCL fixation surgeries.		
What changes would you like to see in the device?		

Appendix C: Surgeon Questionnaire - Dr. Faircloth

Veterinarian: Dr. William Faircloth, DVM, U30 Cat and Small Dog Wellness Center

Before Testing Device		
Question	Explain	
How do you currently perform the CCL fixation surgery?	Depending on dog size, you either put an anchor or a tunnel in the femur, then put a tunnel on the caudal side of the long digital extensor groove and as close to the joint surface as possible (similar to where our T4 point is)	
With your current method, how difficult is it to find the most isometric points?	Never know, 5 years later the crimp is never in the same place and the sutures seem to be broken	
After Testing Device		
Question	Yes or No	Explain
This device is intuitive to use.	Yes	With the basic instructions, would know how to use it
The directions for using the device are easy to understand and are accurate for proper device usage.	Yes	
The device forms to the stifle well.	Yes	The different length pins work but I would rather see the curved version to fit the stifle
This device is easy to hold while drilling.	Yes	I would most likely remove the device before I drill so the hole angle wouldn't matter, but if you were to keep the device on the stifle, the holes need to be angled. I would put a K-wire in the holes, then remove the

		device and use a drill that can drill over the k-wire. K wire might be more accurate than a marker because it goes through the soft tissue but both would be acceptable.
This device will be easy to assemble.	Yes	If you have the labels on the pins, it is intuitive. Might be helpful to have the bars labeled then have a picture in the kit.
This device will be easy to clean	Yes	All practitioners have an autoclave in their shop to sterilize.
I would use this surgical device for CCL fixation surgeries.	Yes	If it located the points, I would pay up to \$500 for one device (up to \$1000 for a set of 5)
What changes would you like to see in the device?	Sell the kit and the sizes individually for people who have specialized clinics or if you lose one set.	

Appendix D: Surgeon Questionnaire - Dr. Murphy

Veterinarian: Dr. Sean Murphy, DVM, DACVS, WestVet

Before Testing Device		
Question	Explain	
How do you currently perform the CCL fixation surgery?	I typically don't perform the surgery. I use a circumfabellar-tibial suture technique. This suture goes around the fabella, actually encircling femoral-fabellar ligament. For the tibial side, we usually drill right in the extensor groove (cranial aspect). Under the LDE and shoot a tunnel across, right at the groove.	
With your current method, how difficult is it to find the most isometric points?	<p>I have not seen a ton of issues with the surgery successes, but research has shown they don't return with regular function. A lot of isometric research has been less and less used because the lateral suture placement has been used less. The TPLO procedure has been becoming more popular.</p> <p>Sometimes they do the circumfabellar-tibial suture technique, and then they do tibia point, and it will seem isometric, but the problem is that the point combination may not stop cranial drawer.</p>	
After Testing Device		
Question	Yes or No	Explain
This device is intuitive to use.	yes	As long as there is clear directions to follow with numbered steps, it is intuitive to use.

The directions for using the device are easy to understand and are accurate for proper device usage.	yes	
The device forms to the stifle well.	yes	Having different length pins to reach the different portions of the stifle will allow the device to form well.
This device is easy to hold while drilling.	no	<p>I recommend having a handle to place it all on the landmarks.</p> <p>Have something fixed before drilling. The best to fixate would be fibular head, or tibia would be best. One of the bottom ones, basically. I really thinks that not fixating it will make the drilling hard.</p> <p>A potential idea to drill a pin perpendicular to the patellar tendon insertion site, and then slide the jig through that to secure the device to the stifle.</p> <p>If you're drilling, the guide should be very stable while drilling. Either that or marking it with a surgical pencil, but that removes the control over the angle of the drilling.</p> <p>I recommend k-wires for fixating the device.</p>
This device will be easy to assemble.	Yes	
This device will be easy to clean	Yes	
I would use this surgical device for CCL fixation surgeries.	Yes	

What changes would you like to see in the device?

Bone anchors break, because of the sharp corners.

Consider the angle for the anchor especially. How the angle of the anchor gives wear to the suture, but still provides pull-out.

Be wary of the hole angle because eventually the angle that you drill the bone anchor in, is the angle in which the suture will come out of.

Fabella is the most important point. He suggests the pins first, and sliding the jig over it.

Your design is better than the one that is on the market now.

Use the measurement between two landmarks on the stifle to get a range of what size device is appropriate for the dog size.

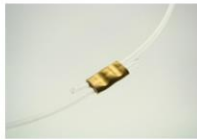
<h1 style="text-align: center;">The Need</h1> <ul style="list-style-type: none"> · CCL disease accounts for 90% of all hind-limb lameness · \$1.3 billion annually spent on CCL repairs · Current suture repair methods fail 19-25% of the time · Current research identifies nearly isometric points between the femur and tibia, but does not necessarily prevent against cranial drawer 	<h3 style="text-align: center;">Who are we?</h3> <p>SECUROS was founded in 1997 to re-shape the veterinary orthopedic industry. There were three key things missing in the industry at that time:</p> <p><i>Quality innovative products</i></p> <p><i>Supreme customer service</i></p> <p><i>A company dedicated to educating the market on new and improved techniques, implants and instrumentation.</i></p> <p>This is what we set out to deliver and has since become known as the "SECUROS Philosophy."</p>	<h2 style="text-align: center;">Anatomic Point Guide</h2> <p style="text-align: center;">for</p> <h3 style="text-align: center;">Lateral Suture Stabilization of the Cranial Cruciate Ligament</h3>
	<h3 style="text-align: center;">Relevant Products</h3> <div style="display: flex; justify-content: space-between;"> <div data-bbox="634 961 813 1083">  </div> <div data-bbox="813 978 1036 1062"> <p>PowerX Crimping Device for Lateral Suture Stabilization</p> </div> </div> <div style="display: flex; justify-content: space-between; margin-top: 10px;"> <div data-bbox="630 1121 829 1220"> <p>Titanium Nitride (TiN) coated crimp clamps</p> </div> <div data-bbox="841 1108 1036 1245">  </div> </div>	



With data from two clinically relevant tests to support it, you can rest assured that our Anatometric Point Guide will accurately and repeatably find the correct points for suture attachment during Lateral Suture Stabilization.



Tibial Translation Test

Suture Strain Test



**Reusable
Accurate
Universal**

For more information call 1 (877) BONEFIX (266-3349), or visit us at www.securos.com

Appendix F: Device Instructions

Device Overview

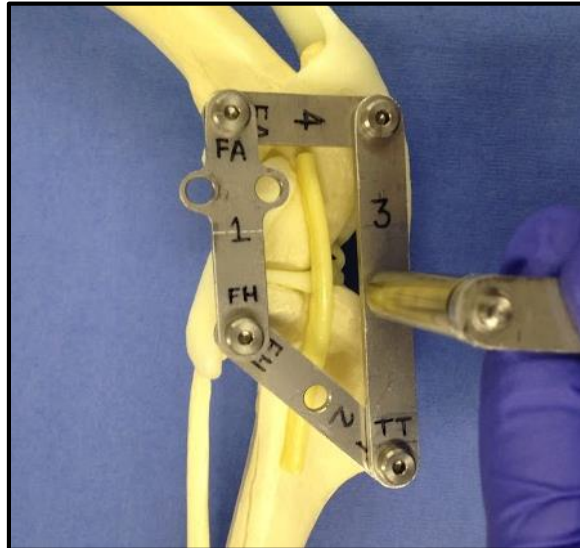

Preparing the Canine Stifle

1. Position the dog so that the lateral side of the injured stifle is facing up or away from the operating table.
2. Bend the stifle so that the angle between the femur and the tibia is 120°.
3. Expose the lateral side of the joint capsule so that the fabella (FA), fibular head (FH), and the point at which the patellar tendon attaches to the tibial tuberosity (TT) are able to be identified.

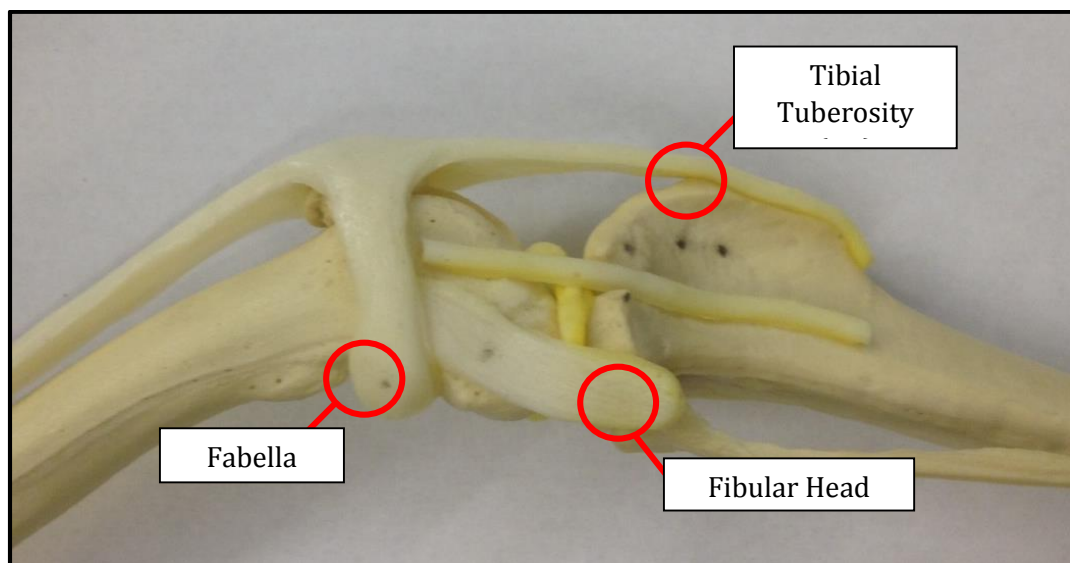

Selecting the Optimum Drill Guide

1. Measure the length from the fibular head to the point at which the patellar tendon attaches to the tibial tuberosity on the lateral side.
2. Using that measurement, select the drill guide that this measurement is within range of. The range is located on the bottom side of each bar and in the drill guide kit.

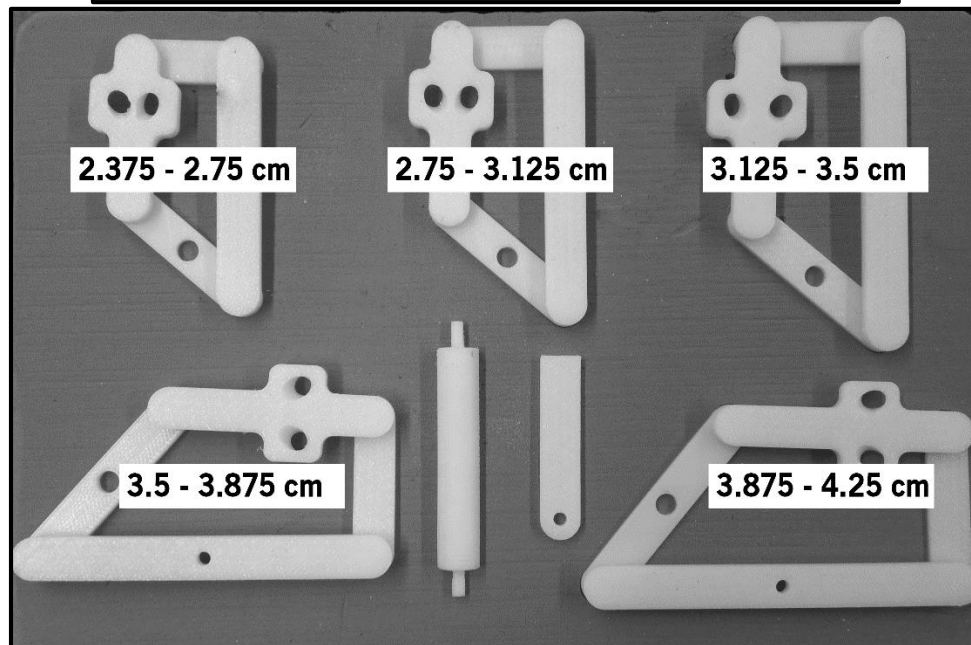
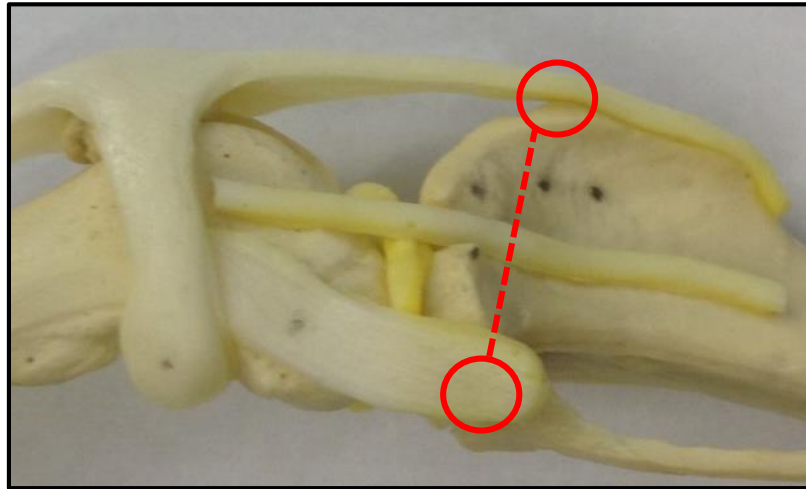

Align the Device

3. Place the “FA” pin located at the junction of bar 1 and 4 on the center of the lateral side of the fabella.
4. Place the “FH” pin located at the junction of bar 1 and 2 on the center of the lateral side of the fibular head.
5. Place the “TT” pin located at the junction of bar 2 and 4 on the point at which the patellar tendon attaches to the tibial tuberosity on the lateral side.



Drill Using the Device

1. Using your non-dominant hand, hold the device in place with the handle.
2. Using your dominant hand, drill a tunnel through the tibia using the hole on bar 2 as a guide.
3. Using your dominant hand, drill a bone anchor on the bone using the inside hole on bar 1 as a guide.
(Note: Two holes exist on bar 1 to allow the device to be used for both the right and left stifle. Only one hole should hover over the femur at a time, making that the optimal hole to use as a guide)

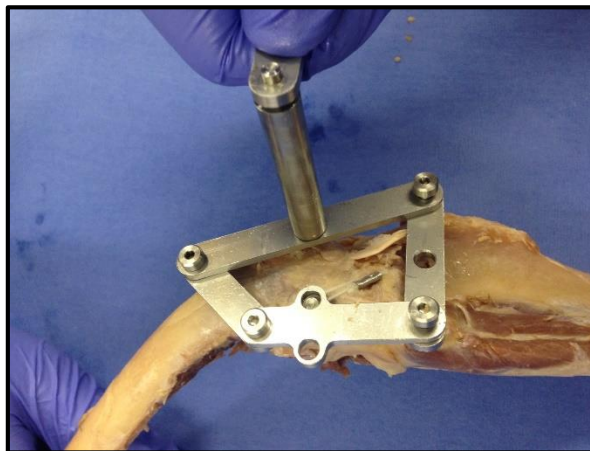

Clean the Device

1. Disassemble each bar away from the other bars so that there are four individual pieces.
2. Perform normal sterilization procedures for stainless steel equipment.
3. Assemble the device back together by attaching each bar in order by the numbers engraved on the middle of the bar (see inside cover of the kit for further instructions).
4. Place the device back into its assigned place within the kit packaging.

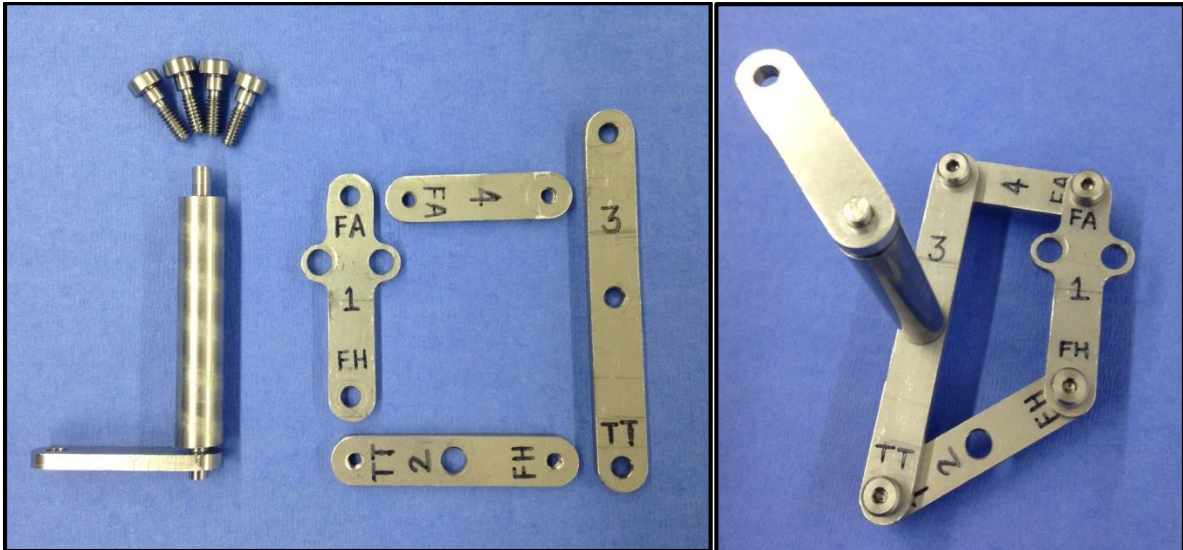

Appendix G: Dimension Table

Label for Scaled Sizes	Bar 1	Bar 2	Bar 3	Bar 4
2.375 – 2.75 cm	3.312	3.190	5.385	2.286
2.75 – 3.125 cm	3.726	3.589	6.058	2.572
3.125 – 3.5 cm	4.140	3.988	6.731	2.858
3.5 – 3.875 cm	1.760	4.387	7.404	3.143
3.875 – 4.25 cm	4.968	4.785	8.077	3.429