



IQP-222

Emergency Burnt Skin Treatment

By Marzhan Mozhanova, Yann-Frederic Schoenhagen, and Jirom Yibrah

An Interactive Qualifying Project

Submitted to the Faculty

of the

WORCESTER POLYTECHNIC INSTITUTE

In partial fulfillment of the requirement for the

Degree of Bachelor of Science

April 27, 2011

Marzhan Mozhanova

Yann-Frederic Schoenhagen

Jirom Yibrah

APPROVED:

APRIL 2011

Advisor: Professor Mustapha Fofana
Mechanical Engineering Department

Abstract

According to the American Burn Association, 450,000 receive medical treatment for burns annually. About 10% of the burn victims are hospitalized, including 5.6% in hospitals with specialized burn centers. Patients who suffer from burns of over 10% of total body surface area typically will need skin debridement. There are currently various methods to debride burnt skin, most of which have their own advantages and disadvantages. The project team focuses on understanding burns and the human skin structure, as well as management of burns within hospitals and ambulances and the recovery process. These project objectives enable us to develop of our own debridement device design.

The report provides information about burn pathogenesis and treatment and care management for burn patients. The group has reached its goal by providing a theoretical basis and general guidelines for designing a debriding device that will eliminate issues and complications currently faced by surgeons performing debridement procedures today.

Table of Contents

<i>Abstract</i>	<i>i</i>
<i>Table of Contents</i>	<i>ii</i>
<i>List of Figures</i>	<i>iv</i>
<i>List of Tables</i>	<i>vi</i>
<i>Acknowledgments</i>	<i>vii</i>
CHAPTER 1. REALIZATION	1
Introduction	1
CHAPTER 2. RESEARCH	3
2. Introduction.....	3
2.1 Human Skin.....	4
2.1.1 Epidermis	6
2.1.2 Dermis.....	7
2.1.3 Hypodermis [Subcutaneous Layer].....	8
2.2 Burn Classification.....	9
2.2.1 Superficial Burns	10
2.2.2 Superficial Partial-Thickness Burns	11
2.2.3 Deep Partial Thickness Burns.....	12
2.2.4 Full-Thickness Burns	13
2.3 Ambulatory Management of Burns.....	14
2.3.1 Rule of Nine.....	17
2.3.2 Stabilization	18
2.3.3 Transportation.....	26
2.4 Hospital Management of Burns.....	28
2.4.1 Burn Assessment.....	29
2.4.2 Burn complications	32
2.4.3 Debridement.....	42
2.4.4 Modern Debridement Procedures	52
2.5 Recovery.....	58
CHAPTER 3. INNOVATION	63
3. Introduction.....	63
3.1 Modern Robotic Technology	64

3.1.1	Robots	64
3.1.2	Robots in the Medical Field.....	65
3.2	Design Iterations	72
3.2.1	Introduction.....	72
3.2.2	Supervisory Controlled System	74
3.2.3	Telesurgical System Implementation Design Options.....	78
3.3	Debriding Device Final Design.....	84
3.3.1	Arm	85
3.3.2	Nozzle	87
3.3.3	Benefits	89
CHAPTER 4. CONCLUSION.....		91
GLOSSARY.....		92
REFERENCES.....		98
APPENDICES.....		103
	Engineering Photos and Drawings	103

List of Figures

Figure 1 - Structure of Human Skin [69]	5
Figure 2 - Epidermis Layer of Skin [27]	6
Figure 3 - Dermis Layer of Skin [27]	7
Figure 4 - Hypodermis Layer of Skin [27]	8
Figure 5 - First, Second, and Third Degree Burns [43]	9
Figure 6 - Drawing of Superficial Burn [49]	10
Figure 7 - Drawing Depicting Superficial Partial Thickness Burn [49]	11
Figure 8 - Deep Partial Thickness Burns [49]	12
Figure 9 - Full Thickness Burn [49]	13
Figure 10 - A Horton Ambulance [34]	14
Figure 11 - Algorithm for the Management of Patients with Burns. [49]	16
Figure 12 - The Rule of Nine [32]	17
Figure 13 - Paramedic Scissors [28]	18
Figure 14 - Saline Soaked Gauze [28]	19
Figure 15 - Burn Cleaning [28]	20
Figure 16 - Silvadene Ointment [62]	22
Figure 17 - Dry Gauze Covering Wound	24
Figure 18 - Medical Morphine [11]	25
Figure 19 - Medical Helicopter [22]	26
Figure 20 - An Algorithm for Medical Transportation [22]	27
Figure 21 - Skin Biopsy [25]	29
Figure 22 - Laser Doppler Imaging [56]	30
Figure 23 - Thermography [13]	31
Figure 24 - Clinical Complications in Burn Victims [10]	32
Figure 25 - Association of Several Complications and Duration of Mechanical Ventilation [10]	33
Figure 26 - Occurrence Complication with Duration of mechanical Ventilation within different age groups [10]	34
Figure 27 - Burn Size Group [10]	44
Figure 28 - Lived/Died by Burn Group Size (%TBSA) [10]	45
Figure 29 - Goulian Surgical Knife [61]	46
Figure 30 - Mechanical Debridement [61]	48
Figure 31 - Autolytic Debridement [65]	50
Figure 32 - Versajet Hydro-Surgery System [23]	52
Figure 33 - SPP(in mmHg) values for the Ultrasound research groups [68]	56
Figure 34 - SPP(in mmHg) values for the surgical debridement research groups [68]	56
Figure 35 - Burn Center Mortality Rates in Fire/Flame Cases [10]	58
Figure 36 - Mean Hospital length of stay for fire/flame cases between 2005-2008 [10]	60
Figure 37 - Phases of Wound Recovery [9]	62
Figure 38 - Sony's Aibo, The Robo-Dog [74]	63
Figure 39 - Robotic Vacuum, Roomba [74]	64
Figure 40 - Military Robots [74]	65
Figure 41 - HONDA's Asimo Robot [74]	66
Figure 42 - RoboDoc Surgical System [59]	68
Figure 43 - Da Vinci System [75]	69

Figure 44 - Nurse preparing a robotic surgery system [75]	71
Figure 45 - Computer Numerical Control Milling Machine [71]	74
Figure 46 - Five-Axis Machining Center [71]	75
Figure 47 - Laser Doppler Blood Flow Imaging of a Human Brain [72]	76
Figure 48-Da Vinci Surgical System Control Console [73]	78
Figure 49 - Da Vinci Surgical System Control Console [73]	79
Figure 50 - Da Vinci Surgical System Control Rings [73]	80
Figure 51 - Da Vinci Surgical System EndoWrist [73]	81
Figure 52 - Da Vinci EndoWrist Specialized Tip [73]	82
Figure 53 - Da Vinci Surgical System in General Procedure Setting [73]	83
Figure 54 - Robotic Arm Design	85
Figure 55 - Engineering Drawing of Robotic Arm	86
Figure 56 - Nozzle Design –Wire View	87
Figure 57 - Nozzle Design	88
Figure 58- Engineering Drawing of Nozzle.....	88
Figure 59- Mock Assembly of Final Project.....	103
Figure 60 - Robotic Arm.....	104
Figure 61- Engineering Drawing of Robotic Arm.....	104
Figure 62 - Nozzle Design	104
Figure 63 - Wireframe View of Nozzle Design.....	104
Figure 64 - Engineering Drawing for Nozzle Design.....	104

List of Tables

Table 1 - Mortality Rate of Patients [10].....	23
Table 2 - Costs of Different Types of Burns [10].....	28
Table 3 - Top Ten Burn Treatment Procedures [20-20.9 Years of Age] [10]	43
Table 4 - Top Ten Burn Treatment procedures for Age group of 80+ years [10]	44

Acknowledgments

The project team would like to give special thanks to everyone that aided the project development, especially the Emergency Medical Technicians and medical staff at University of Massachusetts Medical Center. The EMTs were very helpful in giving us first-hand experience and insight about our topic. They also took time to further explain what procedures take place in the ambulance and how they prepare victims for the hospital, including assessing burns, and the different treatments. Special thanks to EMTs John Schofield, Norman Soucie, and Stephen Haynes EMS Chief of U-Mass Memorial for opening their facilities and answering our questions. A special thanks is due to Professor Fofana, whose passion and vision helped us throughout our project. Professor Fofana's time, effort, enthusiasm, and input were invaluable assets to this team.

CHAPTER 1. REALIZATION

Introduction

The project started with the group's interest in modern medical procedures of burn treatment in ambulatory and hospital settings. Along with our advisor, Professor M.Fofana, whose interest in medical ambulances provided a great setting for the project, the group decided to research and work on advancing the treatment of burnt skin. The research would lead us in the direction of designing innovative way to remove burnt skin from a patient without causing further injury and pain and decreasing the time needed for a patient to recover.

The initial stage of the project focuses on providing a better understanding of not only the causes and effects of burns, but also a better understanding of the human body. Important preliminary research topics include human skin structure, traditional and contemporary burn classifications, methods to assess burns and methods to stabilize a burn patient used by emergency medical staff. More advanced research includes technology used for burn depth assessment, conventional and contemporary burn wound cleaning methods, and possible burn complications and risk factors. This research provides a sufficient understanding of burns and the human body. That leads to an opportunity to focus more on innovation. Within the innovation phase, medical machines and current technology are analyzed, that will allow the project team to develop a design for a machine that will be able to remove the necrotic and burnt skin from a patient. The following are key goals for the device:

- To provide an effective method of burn wound cleaning
- Automating the process of cleaning a burn wound
- Decreasing possibility of human error

- Decreasing the risk of an infection
- Decreasing pain level of the burn wound cleaning procedure
- Decreasing patient recovery period

This interactive qualifying project spanned over a course of typical WPI school year, lasting the 4 terms. Different objectives have been set and accomplished within each of the terms. A-Term was dedicated to collecting statistical data on burns, causes, treatment methods, preventative measures, as well as defining the problem statement and project objectives. B-Term was dedicated to an extensive research on human skin structure, including its layers and components, as well as burn pathogenesis and classification. Also in B-Term, ambulatory management of a patient and initial burn area and depth assessment are scheduled to be looked at as well as burn patient stabilization and transportation from the initial site of the incident to the hospital. The group also plans to visit the University of Massachusetts Memorial Hospital to interview Emergency Medical Technicians about burn patient transportation and stabilization in an ambulance.

During C-Term, the group will conduct research on conventional and innovative methods of burn wound treatment in a hospital setting, as well as benefits and disadvantages of each method. Furthermore, initial research on application of robotic systems in modern surgery will be looked into. In the course of D-Term, the group will develop design for the device based on the contemporary robotic surgery methods and finish the report.

CHAPTER 2. RESEARCH

2. Introduction

Millions of people each year are affected by a medical condition referred to as being burnt. Tanning, or the act of exposing the skin to ultraviolet radiation, is one of the most common cases of burns. A burn is a type of injury to the skin caused by heat and affects the different layers of the skin. In the United States, 500,000 people are estimated to receive medical treatment for burn related injuries every year. While 1% of the total population is a miniscule number of people that are affected by burns, many cases of burns and burn related injuries go unreported. Most of the population will be affected by some type of burn throughout their lifetime. Amid improvements in medical procedures, emergency care, technology and transportation hospitals with specialized burn centers have been on a rise, aiding to the success and survival rate of burn victims.

Among burn injuries, there are sub-categories of burns depending on the type and cause of the burn. The severity of the burn is also taken into consideration. Burns affect the layers of skin, the epidermis being the top layer of skin, followed by the dermis, and the hypodermis being the deepest level. Most burns only affect the epidermis or dermis layer, but more serious burns will penetrate to the hypodermis level. Different types of burns include scalds, contact burns, thermal, chemical, electrical, inhalation, radiation and ultraviolet, each with separate symptoms and procedures. While different degrees of burn were previously classified by I-Degree burn, II-Degree Burn, or III-Degree Burn, these terms are being replaced by the terms superficial burns, superficial partial burns, deep partial thickness burns and full thickness burns. This chapter highlights all of the research done on the various topics associated with burns.

2.1 Human Skin

The human skin is the largest organ in the human body and serves several functions. The skin accounts for around 15 to 20 percent of the total body weight of a person and each square centimeter of skin alone contains 6 million cells, 5,000 sensory points and over 100 sweat glands. The skin is home to hair follicles, capillaries, stratum corneums, nerve endings, and both the sebaceous and sweats glands. The skin is also constantly going through a process of regeneration. Cells are created in the lower layer of the skin and eventually make their way to the top layer of skin, where they stay before dying and eventually shedding, creating space for new skin. This process insures that human skin always healthy (Magrath, et al [41]).

The skin performs many jobs for the human body, and some of the more important jobs include protecting organs, bones, and muscles from injury and preventing the body to exposure of germs. Once the skin is penetrated, the body is vulnerable to different dangers, including infections and viruses. The body is constantly fighting to prevent this from happening. The skin also is an important factor in body temperature regulation. The skin will help keep the body temperature constant indifferent of the temperature outside of the body. This is done using different methods such as sweating, which occurs when the body attempts to keep the body cool from a warmer outside temperature. Lastly, the skin provides the nerve endings that create feeling and sensations (National Geographic [2]).

There are several layers of skin in the human body including the epidermis, top layer, the dermis, the middle layer and lastly the subcutaneous, the lowest level which touches the muscular tissues depending on the region of the body. **Figure 1** shows a depiction of the human skin, with the layers and different component that comprise the skin.

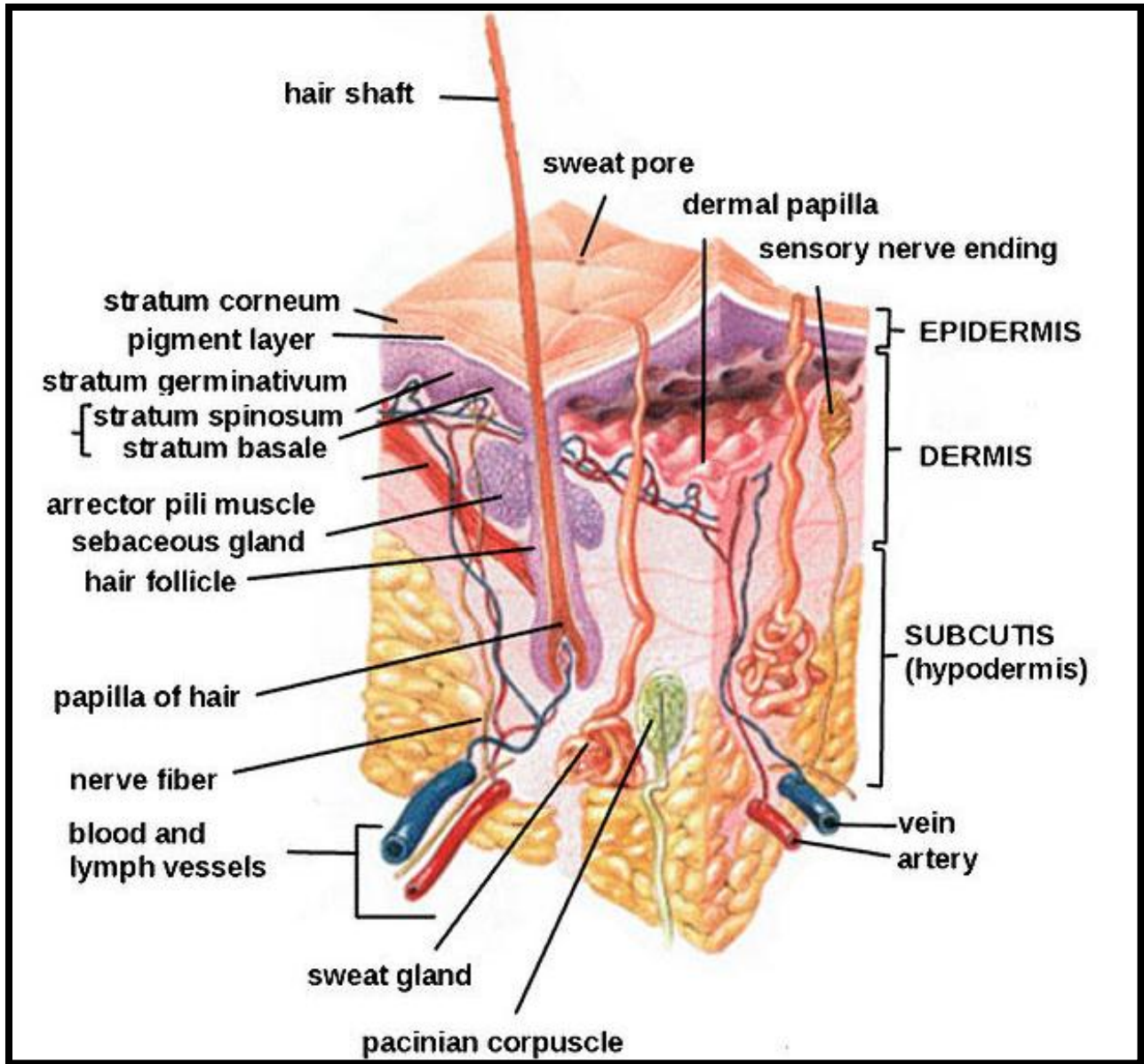

Figure 1- Structure of Human Skin [69]

From this depiction of the structure of the human skin, we gain a better understanding of not only the different layers of the skin, but the different components within the skin and their relative position. Further research into the different layers of the skin follow this section, starting with the epidermis layer, followed by the dermis, and lastly the hypodermis. (Trauma J.,Sevitt S [69]).

2.1.1 Epidermis

The epidermis layer is the outer level of skin that you can see and is made up of several overlapping layers of skin cells. It contains no blood vessels and must use diffusion to receive nourishment from the dermis layer. The outer layer contains dried flattened cells that are constantly being replaced by other cells produced in the lower epidermis level. It takes about five weeks for newly created cells to make it to the top surface. This layer of dead skin is known as the stratum corneum and its thickness varies throughout the body. For example, the stratum corneum layer is much thicker around the soles of the feet than around the fingers. (Magrath, et al. [41]).

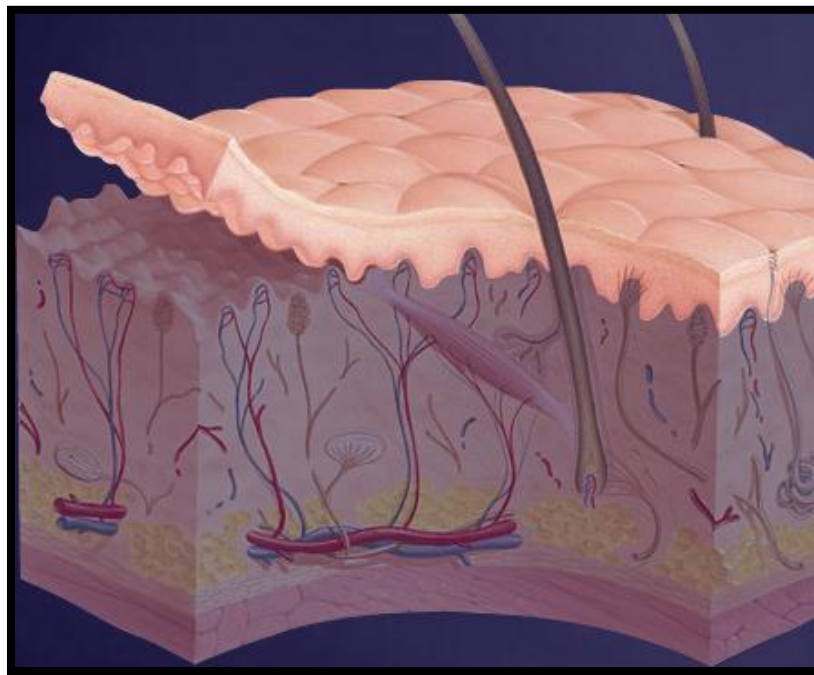

Figure 2- Epidermis Layer of Skin [27]

Figure 2 shows the Epidermis layer of the skin, whose skin cells contain proteins such as keratin, also found in hair and fingernails, which help keep moisture inside and keep the skin surface waterproof (National Geographic [27]).

2.1.2 Dermis

Below the initial layer of skin, is the dermis layer, which is a strong, thick and flexible layer composed of collagen and elastin, which gives the skin the strength and elasticity. Within the dermis layer are networks of blood vessels that help in regulating body temperature. This is done by increasing blood flow to the skin to allow heat to escape when overheated, or restricting the blood flow in an attempt to increase body heat when cold (Magrath, et al. [41]).

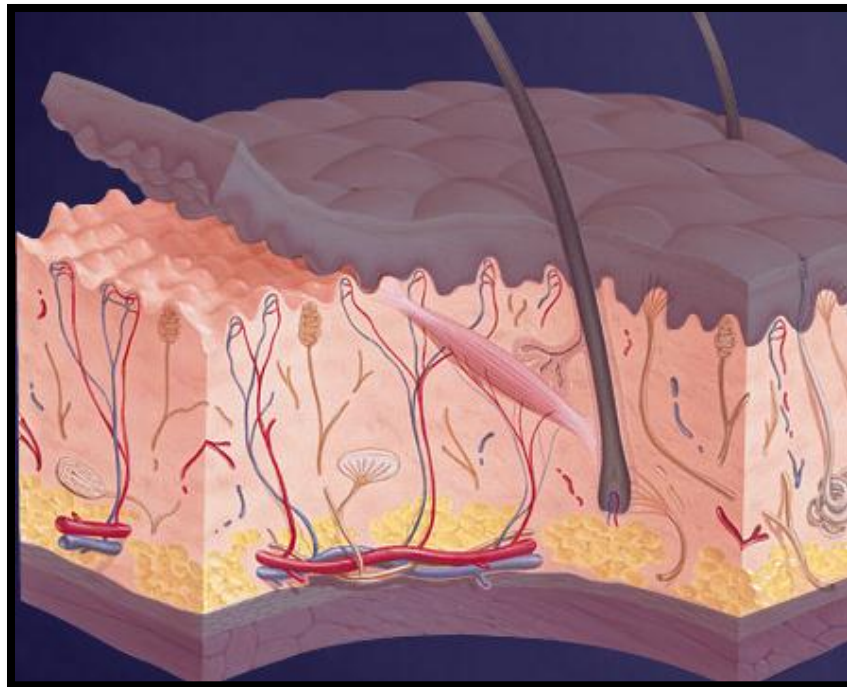

Figure 3- Dermis Layer of Skin [27]

Figure 3 shows the dermis layer of the skin, along with some of the components within the dermis layer that include a network of nerve fibers as well as receptors that detect pressure, pain, and temperature. It is also in this layer where the hair follicles and sweat glands are located (National Geographic [27]).

2.1.3 Hypodermis [Subcutaneous Layer]

Underneath the dermis layer, is the subcutaneous layer also known as the hypodermis layer, which is a seam of fat used as a fuel reserve as well as for insulation and cushioning. This layer also serves as a layer between the outer layers of the skin and the underlying bone and muscle. **Figure 4** shows the hypodermis layer of skin which acts as an energy reserve, by storing different fats that can be put back into circulation and eventually turned into energy (Magrath, et al. [41], National Geographic [27]).

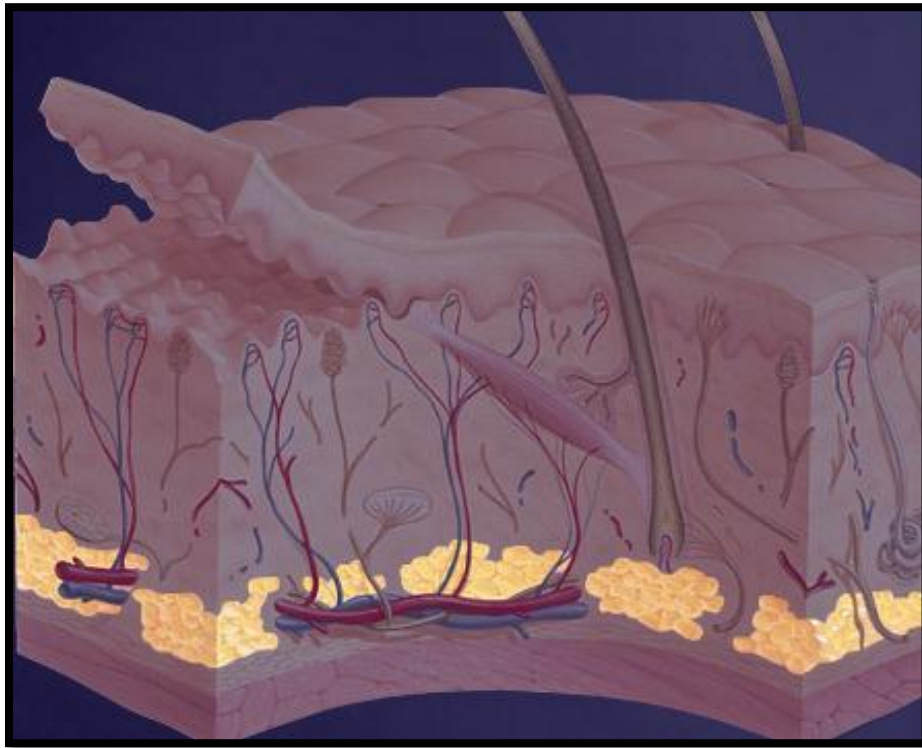

Figure 4- Hypodermis Layer of Skin [27]

2.2 Burn Classification

Defining different burns degrees is done by analyzing the depth and geometry of the burn. A recognized method for defining these degrees has been to define them as I, II, or III-degree burns, with burn injury and depth increasing as the degrees increase. The different burns and effects on the layers of skin are shown in **Figure 5**. I-Degree burns affect the epidermis layer of skin, which allows the skin to still retain its normal functions but causes redness and swelling. Typically these types of burns are not serious enough to require special medical attention and being sun-burnt, or tanning, is a typical example of such a burn (Mayo Clinic [43], American Family Physician [49]).

II-Degree burns are more serious than the I-Degree burns. They affect the epidermis, dermis, sweat glands, and the hair follicles. The normal skin functions will not perform normally and the burn will cause pain, blisters, redness and swelling. The last degree of burns, III- Degree, destroys the epidermis, dermis, and all the way to the hypodermis. This can affect fat, muscles, and the bones. The skin can be completely destroyed, eliminating all the skin functions. The skin will appear white, black, and charred. This form of burn requires immediate medical treatment. These traditional terms are being replaced by more detailed expressions, which are superficial, superficial partial thickness, deep partial thickness and full thickness. The research into the current methods to define burn degrees are in the proceeding sections (Mayo Clinic [43], American Family Physician [49]).

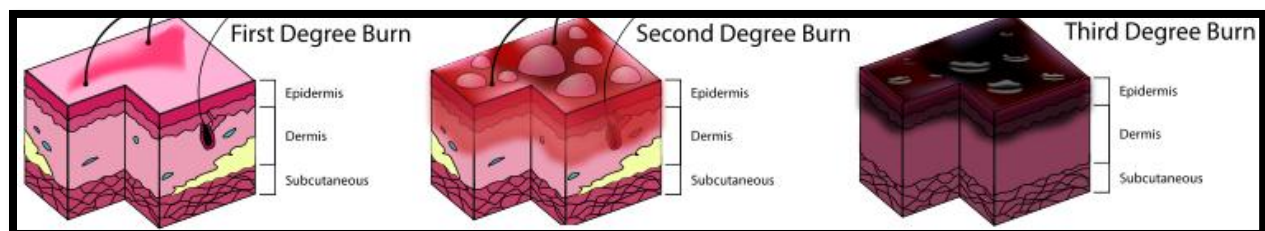

Figure 5- First, Second, and Third Degree Burns [43]

2.2.1 Superficial Burns

Superficial burns are generally painful with a dry irritated complexion on the surface of the epidermis. These types of burns may be caused from ultraviolet light, which is typically caused by exposure to the sun. A very short flash flame is also known to induce a superficial burn. The healing times for these burns are typically small, ranging from 3 to 6 days. These types of burns normally leave little to no scarring. Characteristically, these burns are recognized by red burns that blanch with pressure (American Family Physician [49]).

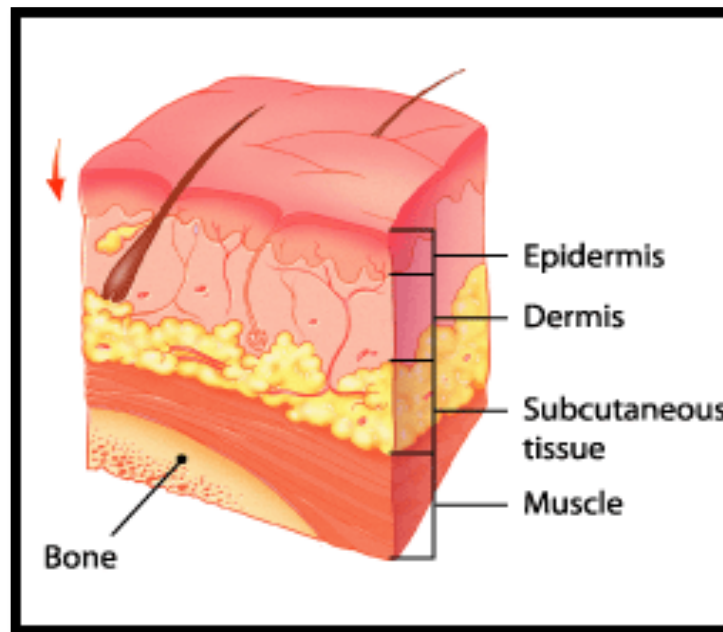

Figure 6- Drawing of Superficial Burn [49]

Shown in **Figure 6** is a depiction of superficial burns on the human skin. This provides us with a better understanding of the severity of the burns, as well as the depth of the burns on the human skin. Similar figures are used in proceeding chapters (American Family Physician [49]).

2.2.2 Superficial Partial-Thickness Burns

Superficial partial-thickness burns, previously known as II-degree burns, are characterized as burns that extend through the epidermis skin layer down to the dermis layer. A superficial partial-thickness burn can be caused by scalding water or a short flash, among many other causes. This wound is sensitive to air and temperature, making it important to protect the wound as much as possible. The typical recover time ranges from about 7 to 20 days and slight scarring and pigmentary change is possible (American Family Physician [49]).

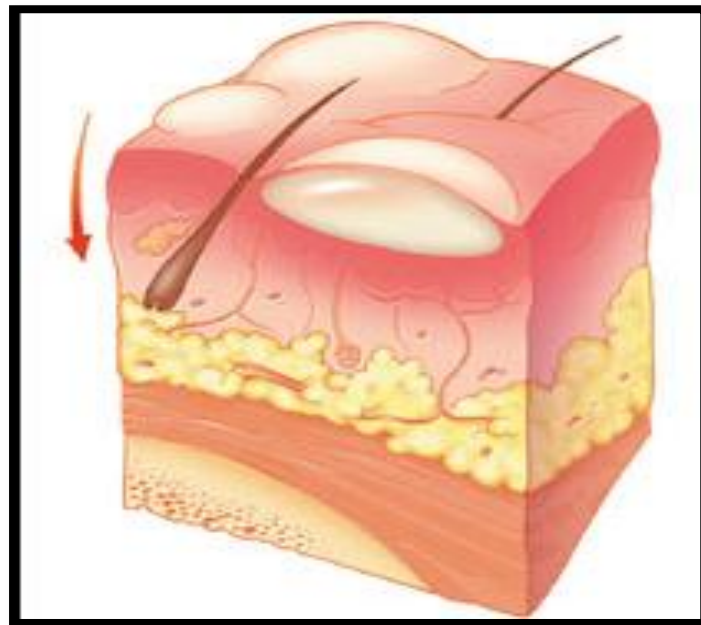

Figure 7- Drawing Depicting Superficial Partial Thickness Burn [49]

Shown on **Figure 7** is a drawing depicting the swelling and damage done by a superficial partial thickness burn. The skin shows signs of surfacing blisters. Wounds that appear red and moist are a clear sign of the superficial partial thickness burn. When pressure is applied to the irritated region of the skin, it will blanch out and when the pressure is released rapid capillary refill will occur (American Family Physician [49]).

2.2.3 Deep Partial Thickness Burns

Deep partial thickness burns can be caused by a range of entities such as scalding liquid, a flame, grease from a frying pan or different venues. A victim of a burn this intense is at risk of contracture. A contracture is a continuous contraction in the absence of electrical stimuli from the nervous system. Deep partial thickness burns are very painful and leave dry waxy blisters on the damaged region. Within minutes of a burn injury, these thin walled blisters surface. If these blisters were to break, this would leave the nerve endings exposed. This can lead to the burned region becoming highly sensitive to touch or temperature. Exposure to the nerves makes these wounds extremely painful (American Family Physician [49]).

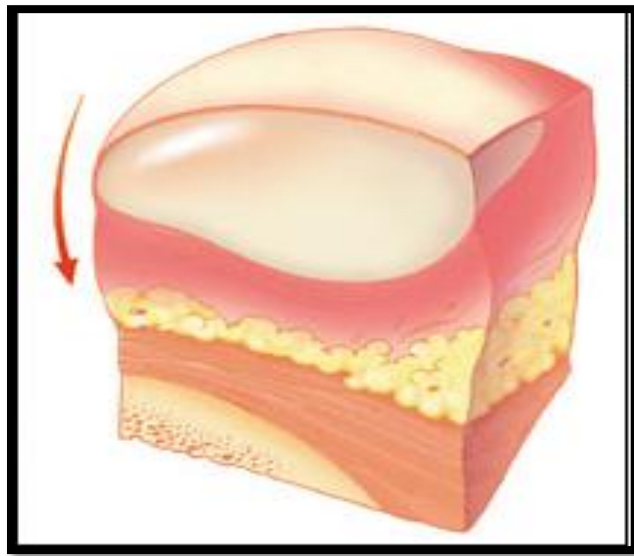

Figure 8- Deep Partial Thickness Burns [49]

Figure 8 shows swelling of the epidermis and damage to the skin layers. Deep partial thickness burns can be classified as severe II-degree burns. These burns are characterized by easily unroofed blisters that have a waxy appearance and do not blanch with pressure. A wound of this magnitude takes over 21 days to recovery from (American Family Physician [49]).

2.2.4 Full-Thickness Burns

A full-thickness burn can be caused by scalding water, flame, steam, oil, grease, chemical, high voltage electricity, among others. The victim is at risk for very severe contracture. The victim is also at risk of a damaged subcutaneous, which occurs when the nerve endings are cut, and gives a deep pressure sensation. If the wound takes up more than 2% of the total body surface area then the burn is at risk never to heal. This type of burn is very dry, inelastic, and has a leathery gray texture. Full-thickness burns share many symptoms with third degree burns. A full-thickness burn extends through the epidermis and dermis and into the subcutaneous tissue layer (American Family Physician [49]).

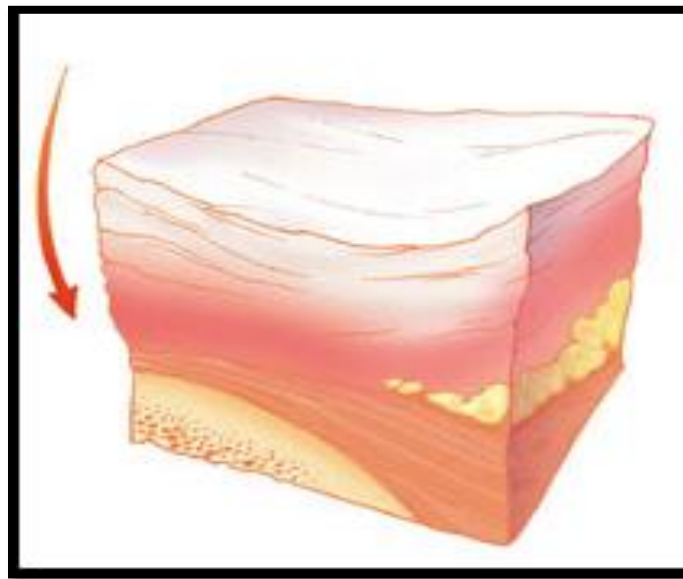

Figure 9- Full Thickness Burn [49]

Figure 9 depicts full thickness burn on the human skin. A burn of this magnitude damages muscle, bone, and interstitial tissue. Within hours, fluid and protein shift from capillary to interstitial space, causing swelling. An immediate immunologic response to injury makes wound sepsis a potential threat. The nerve endings are also compromised, thereby reducing the sensation of pain. Burn areas of this type are characteristically insensate and waxy white or leathery gray in color (American Family Physician [49]).

2.3 Ambulatory Management of Burns

Burn injuries are the third leading cause of accidental death in the United States, after incidents involving motor vehicles and firearms. Each year in the USA, more than 1 million people seek medical care for burns and more than 95% of these patients can be managed on an ambulatory basis. Ambulatory management of burns can be divided into acute treatment and follow-up care. Acute management includes measures to minimize further damage to patients; prevent infection and relieve pain. During follow-up care, the focus shifts to limiting disfigurement from scarring and dysfunction from contractures (Johnson M., Reg R.[34]). It is an EMT's responsibility to determine whether a burn patient should be hospitalized for hydration and burn care or whether ambulatory management appears feasible. Classification of burns as minor, moderate or major facilitates preliminary hospitalization decisions.



Figure 10- A Horton Ambulance [34]

The American Burn Association has established criteria for determining which patients can be managed as outpatients and which require hospital admission or referral to a burn center. A diagram of the decision making process is shown in **Figure 11**. Follow-up care is important to assess patients for infection, healing and ability to provide proper wound care (American Family Physician [49]). Early surgical referral can often help prevent or lessen scarring and contractures.

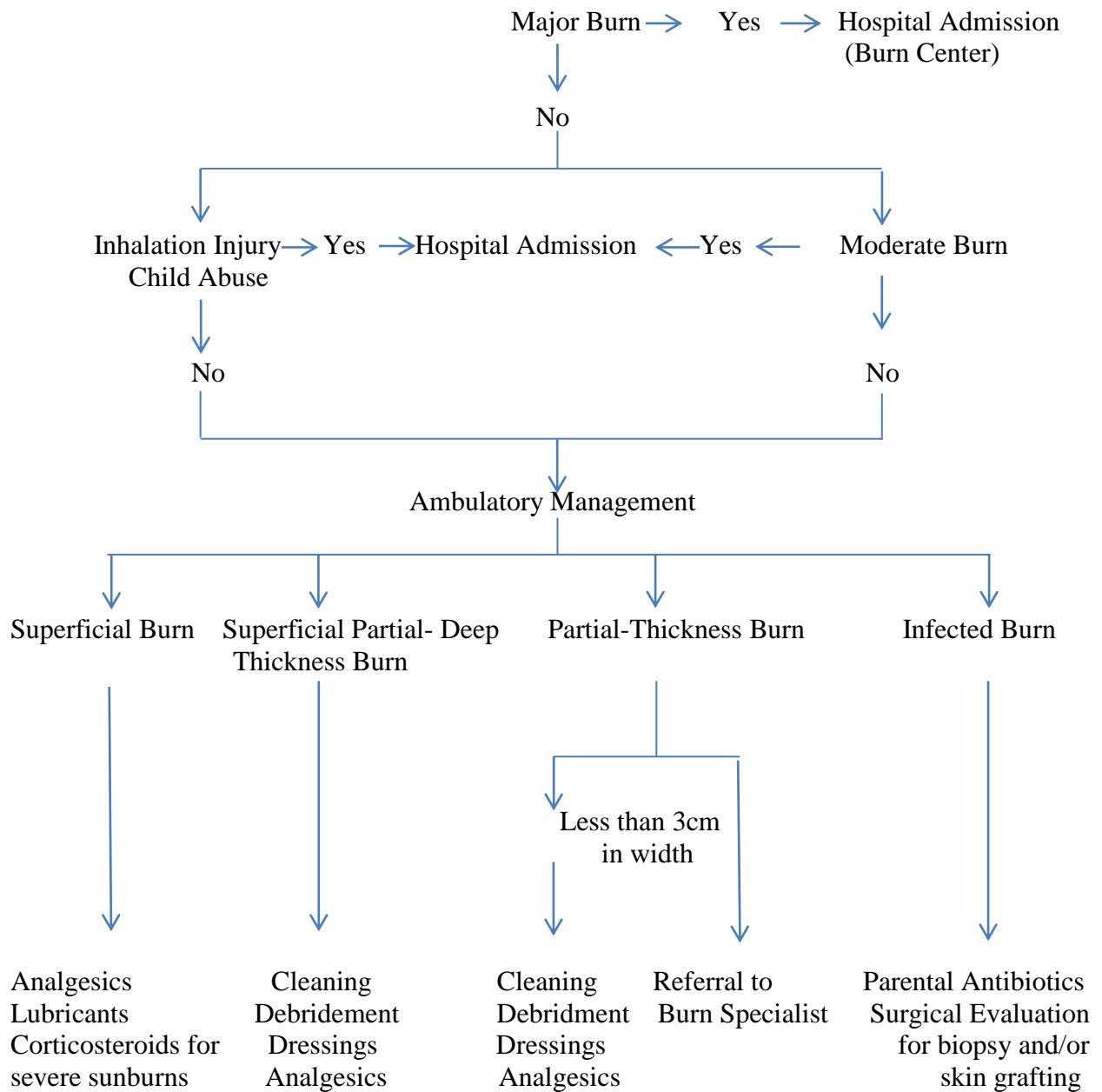

Figure 11- Algorithm for the Management of Patients with Burns. [49]

2.3.1 Rule of Nine

The depth and extent of a burn can be expressed as the total percentage of body surface area, shortened to TBSA, affected by the injury. Accurate estimation of the TBSA of a burn is essential to guide management. The best known method, known as the "Rule of Nine," is appropriate for burn related injuries in all adults and when a quick assessment is needed for a child. The TBSA is divided into eleven sections and each section is 9% of the total skin surface. Depending on how intense the region of the burn is, an EMT can classify the injury (American Family Physician [32]). **Figure 12** shows the percentage of each major body section to the total body surface area.

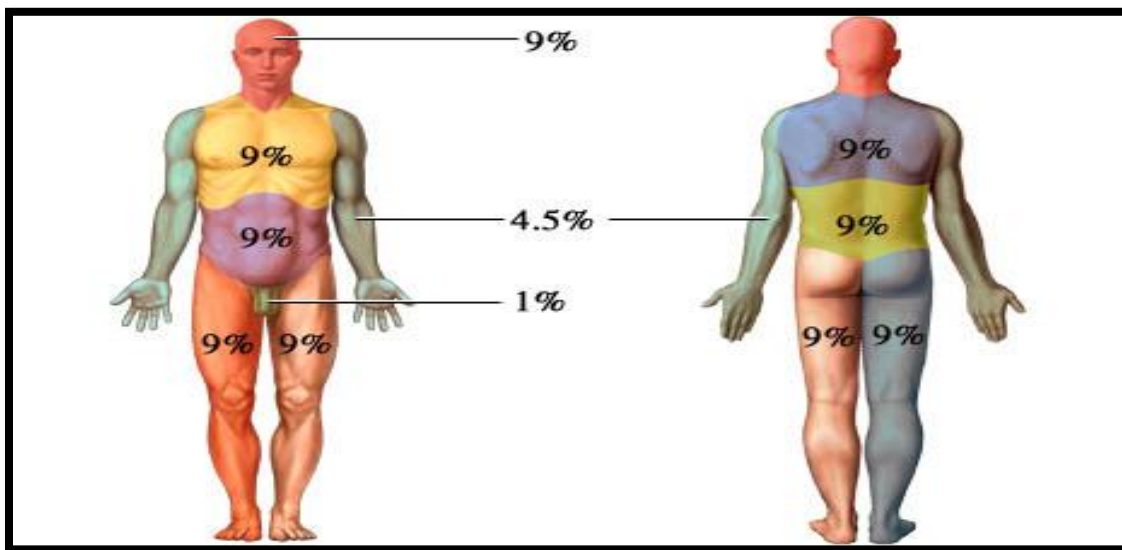

Figure 12- The Rule of Nine [32]

Patients considered to have moderate burns should be admitted for intravenous hydration and surgical care of their wounds. Minor burns comprise approximately 95 percent of burn injuries treated by physicians in the United States. Most of these burns can be managed on an outpatient basis.

2.3.2 Stabilization

A systematic approach to the ambulatory management of burns is conceptualized by the six "Cs": clothing, cooling, cleaning, chemoprophylaxis, covering and comforting or pain relief. These are the main factors that paramedics need to consider when first coming into contact with a victim of a burn. The proceeding sections will further analyze each of these factors.

Clothing

Clothing that is burned should be removed immediately from the patient's body. Clothing that has been exposed to chemicals should also be removed to avoid exposing the skin to continued burn exposure. If clothing does not remove easily, non-adherent material should be cut away (American Family Physician [32]). To cut through the material, EMT's typically use stainless steel scissors, as shown in **Figure 13**, which are EMT utility scissors.



Figure 13 - Paramedic Scissors [28]

Cooling

Burns should be cooled immediately after they occur, and further cooling might be needed through the principal hours after injury to effectively decrease burn pain. Sterile saline-soaked gauze, cooled to around 53.6°F, can be applied to the burned tissues. Shown in **Figure 14** is a saline soaked gauze applied to a foot. To avoid the risk of hypothermia, caution should be exercised in cooling extensive burns (American Family Physician [32]).



Figure 14 - Saline Soaked Gauze [28]

Cleaning

Cleaning a burn wound is critical but can cause excruciating pain. It is therefore important to properly administer anesthesia before the wound is cleaned. Anesthesia should not be applied topically to a burn or injected directly into the wound. Disinfectants are often employed to clean burn wounds, though their use is discouraged because these agents can inhibit the healing process. Washing burns with mild soap and then rinsing with water is a method that has been becoming more popular (American Family Physician [32]).

Figure 15 depicts the cleaning a burn wound with saline solution. In order to minimize infection for partial and full-thickness burns, the burns should be removed manually or with whirlpool debridement. The whirlpool debridement method tends to be better tolerated by patients.



Figure 15 - Burn Cleaning [28]

Chemoprophylaxis

Stabilization and transportation are the top two priorities paramedic considers when dealing with a burn patient. Preventing infection is also a key issue which can be done through chemoprophylaxis. Chemoprophylaxis refers to the administration of a medication for the purpose of preventing infection. The use of chemoprophylaxis is limited primarily by two factors, risk and financial costs. Tetanus immunization should be updated in patients with wounds deeper than a superficial partial-thickness burn. Because of its lower cost, Bacitracin is often favored over silvadene for topical treatment of burns, but no studies support that one agent is better than the others. For burn infections, Silver sulfadiazine cream is used but should not be used on pregnant women, newborns or nursing mothers with infants younger than two months of age. Bacitracin is an alternative topical prophylactic antibiotic. This agent should always be used around mucous membranes. Because of the decreased cost, several authors favor using bacitracin rather than silver sulfadiazine for any superficial partial-thickness burn. No studies comparing the efficacies of bacitracin and silver sulfadiazine have yet been published (Johnson M, Reg R [34]).

Bismuth-impregnated petroleum gauze and biobrane dressings appear to be advantageous treatments and are acceptable for use in young children with superficial partial-thickness burns. Both of these dressings are applied as a single layer over the burn, followed by a cover of a bulky dressing. The bulky dressing should be changed every other day, typically in a physician's office, with close assessment of the wound for signs of infection. All medications have the potential to cause side effects. In general, chemoprophylaxis should be initiated only when the benefits of treatment outweigh the risks. The cost associated with chemoprophylaxis may be expensive,

particularly when the cost of treatment is high. Many forms of chemoprophylaxis are therefore not cost-effective.



Figure 16 - Silvadene Ointment [62]

Above **Figure 16**, is a chemoprophylaxis cream used on burn wounds to prevent infection. There are various different packing and creams out in the market today and typically vary by discretion of the hospital.

Below on **Table 1**, is a table representing mortality rate ranging from the ages of 20-30 that may have been reduced by the use of chemoprophylaxis, and is sub divided into the different percentages of total body surface area that the burn covers.

Table 1- Mortality Rate of Patients [10]

LIVED/DIED BY BURN GROUP SIZE (% TBSA)				HOSPITAL DAYS BY BURN GROUP SIZE (% TBSA)		
	Lived	Died		Cases	Mean +/- SEM	
%TBSA	Cases	Cases	Mortality Rate	%TBSA		
0.1 - 9.9	10,494	11	0.1	0.1 - 9.9	10,505	4.8 +/- 0.1
10 - 19.9	2,850	20	0.7	10 - 19.9	2,870	10.1 +/- 0.2
20 - 29.9	685	20	2.2	20 - 29.9	905	17.7 +/- 0.5
30 - 39.9	406	22	5.1	30 - 39.9	438	31.5 +/- 1.2
40 - 49.9	195	19	8.9	40 - 49.9	214	45.2 +/- 2.5
50 - 59.9	126	24	16.0	50 - 59.9	150	54.6 +/- 3.1
60 - 69.9	84	28	25.0	60 - 69.9	112	55.8 +/- 4.3
70 - 79.9	38	25	39.7	70 - 79.9	63	68.1 +/- 7.4
80 - 89.9	27	39	59.1	80 - 89.9	66	61.5 +/- 10.1
≥ 90	15	57	79.2	≥ 90	72	34.9 +/- 8.3
Subtotal	15,120	265	1.7	Subtotal	15,385	9.4 +/- 0.1
Missing or 0%	6,680	156	2.3	Missing or 0%	6,836	6.1 +/- 0.2
TOTAL	21,800	421	1.9	TOTAL	22,221	8.4 +/- 0.1
Total N=22,221				Total N=22,221		

Covering

Covering burns serves a number of purposes. Dressings provide anesthetic relief, act as a barrier against infection and keep the wound dry by absorbing drainage. Types of coverings differ, depending on the depth of a burn and its location. All partial and full-thickness burns should be covered with sterile dressings. A fine mesh gauze should be applied after the burn has been cleaned and a thin layer of topical antibiotic has been applied (Bioskinrevival [16]).



Figure 17 - Dry Gauze Covering Wound

Figure 17 is an image of an arm with partial thickness burns that has been properly covered by a dry gauze dressing. Circulatory impairment is minimized by applying a non-adherent dressing in successive strips, rather than wrapping it around the wound. The dressing is then held in place with a tubular net bandage or lightly applied gauze wraps.

Comforting

Analgesics should be given around the clock to control "background" pain. Tylenol and non-steroidal anti-inflammatory drugs can be administered alone or in a combination with opioids. This combination is often appropriate for use in patients with small burn wounds. Patients with burns often require a "rescue" medication, which tends to be Tylenol with Codeine or morphine, before dressing changes and during increased physical activity (American Family Physician [49]).



Figure 18 - Medical Morphine [11]

Figure 18 is a bag of morphine mixed with saline used by EMTs to comfort patients with severe burns. These types of morphine bags are common in medical settings and are frequently used.

2.3.3 Transportation

Regularly burn patients are transported by an ambulance. However to avoid the vibrations, insufficient medical supplies, and spatial constraints, helicopter have become a viable option. **Figure 19** shows a medical helicopter being used. Burn patients that are typically transported to hospitals through a ground ambulance are now able to be safely transported via helicopter with trained staff onboard. (Chipp, et al [22])



Figure 19- Medical Helicopter [22]

Helicopters have several advantages to the more common ground transportation, as well as disadvantages. Depending on the different factors of a situation, either ground transportation or aerial transportation will be chosen.

Figure 20 is an algorithm that could prove useful when determining if a helicopter or ambulance is needed. The figure depicts the thought and decision process used by paramedics on a daily basis in deciding how to transport a patient.

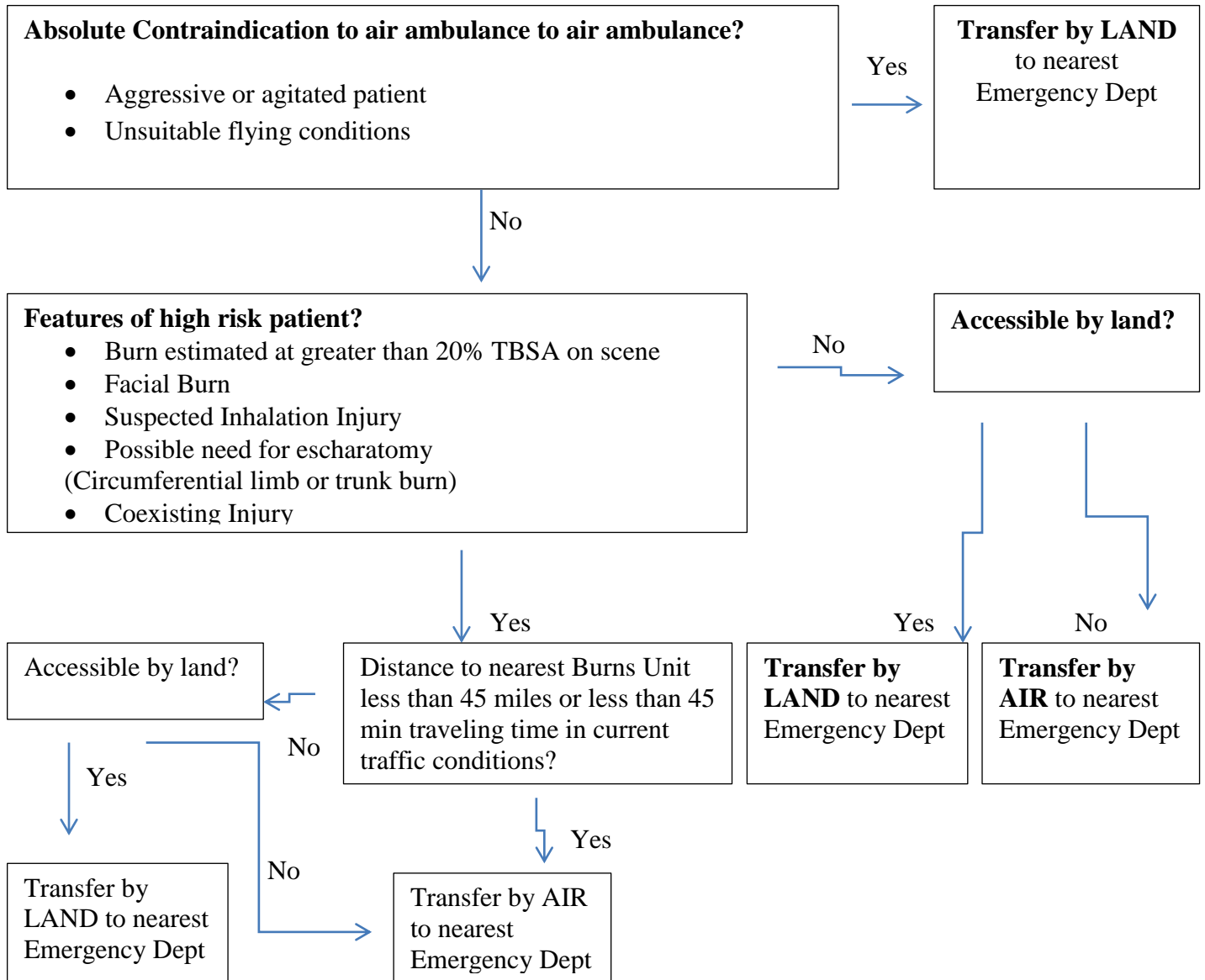

Figure 20- An Algorithm for Medical Transportation [22]

2.4 Hospital Management of Burns

The essential aspects of wound management are an initial assessment, followed by necrotic tissue removal, dressing and recovery monitoring. In order to design a method that would effectively treat burn victims, cost-efficiency should be investigated. The variation of burns range from non-extensive, I-degree, to extensive full thickness burns, III-degree, and the cost difference between the two is over a quarter of a million dollars. This is why paramedics treating extensive III- degree burns, tend to focus on a speedy transportation as they do not have the proper equipment to appropriately treat them (American Burn Association [10]). Below on **Table 2**, is a table representing the costs needed to treat and stabilize patients with varying degree of burns.

Table 2- Costs of Different Types of Burns [10]

MS-DRG Code	Cases	Cases with Valid Charges	Mean +/- SEM
935 Non-extensive burns	6,516	3,231	\$18,851 +/-679
929 Full thickness burn w skin graft or inhal inj w/o CC/MCC	1,672	680	\$82,403 +/-5,272
928 Full thickness burn w skin graft or inhal inj w CC/MCC	937	493	\$152,123 +/-9,593
934 Full thickness burn w/o skin grft or inhal inj	578	332	\$35,058 +/-5,197
927 Extensive burns or full thickness burns w MV 96+ hrs w skin graft	575	247	\$354,514 +/-38,570
Total N= 10,278			

2.4.1 Burn Assessment

Burns are dynamic wounds and need to be reassessed during first 72 hours, as they can alter due to inadequate treatment or infection. Estimation of burn depth is very subjective, as an independent comparison among experienced surgeons showed 60-80% concurrence. Furthermore, depth may vary from one area of the burn to another. Shallow and full thickness burns are the most easily detected types of burns by clinical observation, whereas superficial and deep-partial thickness wounds are difficult to estimate correctly. Different criteria are exploited by different assessment methods to determine burn depth. For example detection of dead cells can be done by skin biopsy, evaluation of skin density, and assessment of dermal circulation with fluorescein. There is also work being done with laser Doppler flowmetry, monitoring wound temperature by thermography, and color coding of burn wounds by light reflectance. **Figure 21** depicts a burn assessment method known as skin biopsy.

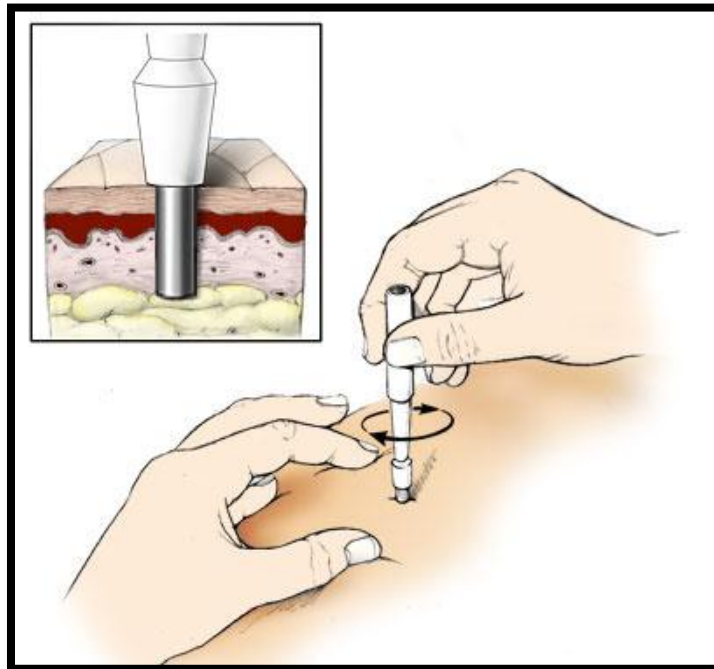

Figure 21- Skin Biopsy [25]

Some of these methods, such as thermography, which bases of temperature gradient between burnt and intact skin, or transcutaneous video microscopy, which uses direct visualization of dermal capillary integrity, optical measurement, nuclear imaging, noncontact and high-frequency ultrasound are still largely experimental. Fluorescein has great diagnostic limitations as it does not differentiate between superficial and deep partial thickness burns. Its dosing is also limited by renal clearance and capillary leak.

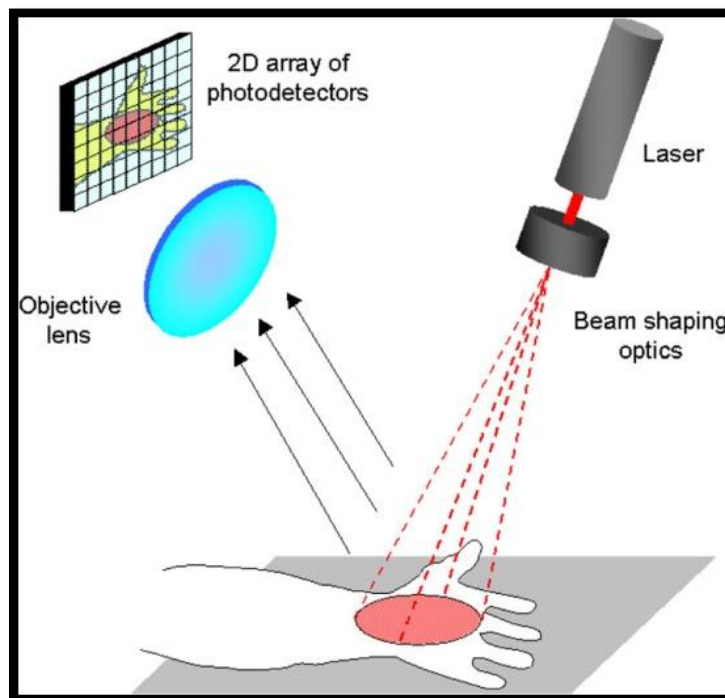

Figure 22- Laser Doppler Imaging [56]

Figure 22 depicts a burn assessment method known as Laser Doppler Imaging. Laser Doppler techniques, which assess skin blood flow, show to be 90-100% sensitive and 92-96% specific for estimating burn depth. Besides the need of close contact with the wound which results in a higher risk of infection, laser Doppler equipment is very expensive and only used in special burns units (Devgan [26]).

Figure 23 depicts the burn assessment method known as Thermography



Figure 23- Thermography [13]

2.4.2 Burn complications

There can be various types of complications in burn patients, such as hypothermia, hypovolemic shock, malnutrition, dehydration and infection. **Figure 24** depicts the number of complications in all case records in the for the American Burn association. Most prevalent complications include pneumonia, cellulitis and infections (American Burn Association [9]).

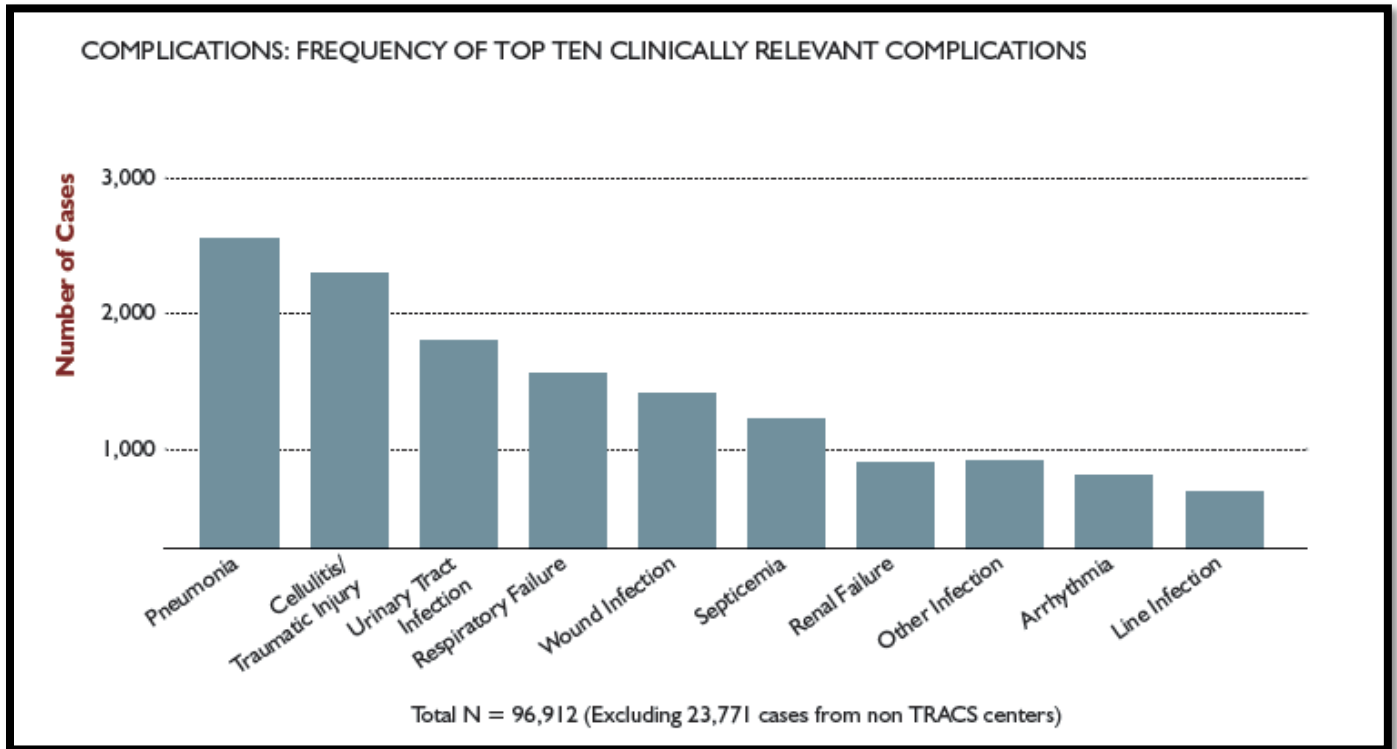

Figure 24- Clinical Complications in Burn Victims [10]

From this figure, we're able to see that pneumonia, cellulitis/traumatic injury, respiratory failure, and wound infection comprise a big part of the complications in all of the cases. These cases may become worse or better depending on length of complications. Data has been collected regarding the frequencies of complications and their comparison to the duration of days of mechanical ventilation (American Burn Association [9]). **Figure 25** demonstrates this association of complications and the duration of mechanical ventilation. The complications are

sub-divided into different durations of days on the ventilator. First sub-division duration is zero days on the ventilator, the second sub-division duration is one to three days, and the last sub-division duration is four or more days on the ventilator.

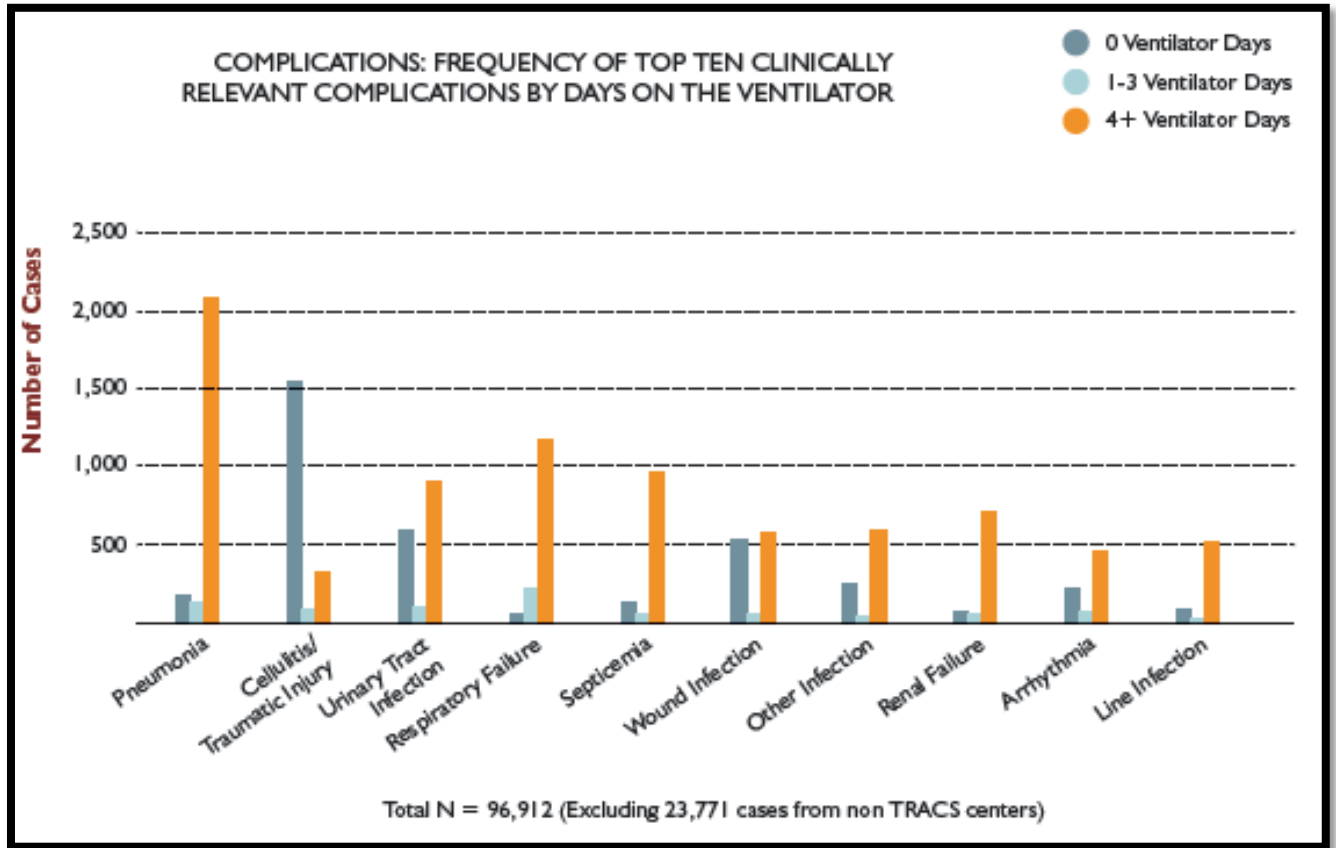

Figure 25- Association of Several Complications and Duration of Mechanical Ventilation [10]

The complication rate, in terms of percentage, has also been researched. It shows throughout the different age groups, with increasing amount of days that a patient is on the ventilator, there is a large increase in the amount of rise of complication rate.

Figure 26 depict the association between occurrence of a least one complication, with duration of mechanical ventilation in different age groups.

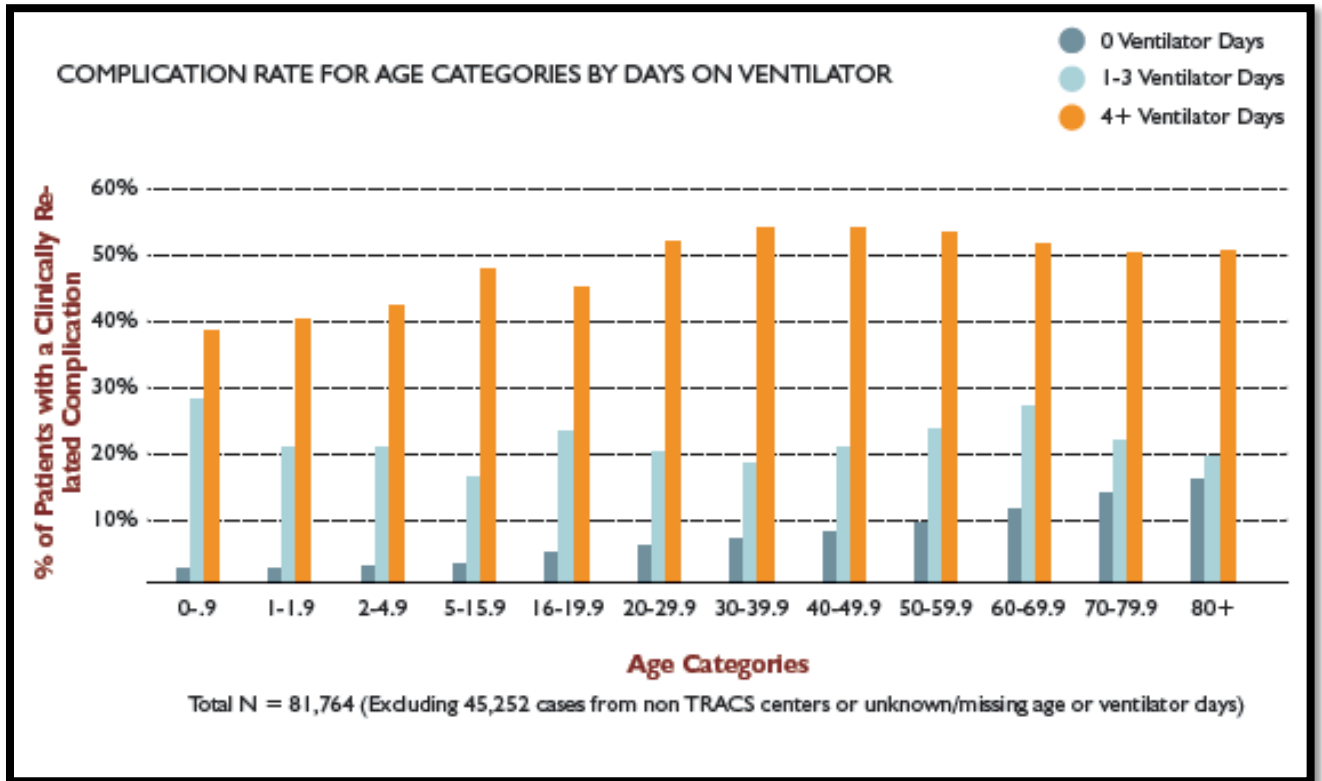

Figure 26- Occurrence Complication with Duration of mechanical Ventilation within different age groups [10]

These figures provide a better understanding of the amount of complications that occur with burn patients, and more specifically the increase of complications once on a ventilator. In the proceeding sections, important and prevalent burn complications are looked into.

Hypothermia

Hypothermia is a medical condition that occurs when the body loses heat faster than it is able to produce heat, which causes a dangerously low body temperature. The normal body temperature is around 98.6 F (37 C) and hypothermia occurs when the body temperature passes below 95 F (35 C). When the body temperature drops to a lower temperature, organs such as the heart or the nervous system are unable to function properly. This can lead to a complete failure of organs and eventually death. While treating burn patients, cooling is used to treat burns. Much care is required as cooling may lead to hypothermia especially among those in the lower age groups and those with larger burn surface areas and higher burn classes.

Strategies to prevent hypothermia include a warmed room, warm air, warming blankets, and countercurrent heat exchangers for infused fluids. There are cooling products on the market are able to cool a burn while greatly reducing the risk of hypothermia. But these products admit that any type of cooling done to a patient leaves the risk of hypothermia. Metabolic responses can be minimized by treating the patient in a thermo neutral environment (32°C). During hydrotherapy, in both the operating room and the burn unit, the room temperature is kept at 85°F to minimize heat loss and decrease metabolic rate (Mulholland M., Doherty G [53]).

Hypovolemic Shock

Hypovolemic shock is an emergency condition in which severe blood and fluid loss makes the heart unable to pump enough blood to the body. This can cause organs to stop functioning. This is a cause of concern within burn patients due to the decrease of circulating blood in the body when a patient loses too many other body fluids. Losing about 20% of the normal amount of blood in the body can cause a patient to go into hypovolemic shock.

Proper fluid management is critical to the survival of a burn victim. While once a leading complication cause of death, an increasing understanding of the fluids and vascular changes that occur during burn shock has led to a decrease in cause of deaths. Hypovolemic shock is prevented by replacing lost fluids by fluid resuscitation and blood transfusions (Mulholland M., Doherty G [53]).

Dehydration

Dehydration is another type of complication that is due to the loss of fluid, which burn victims are vulnerable to. Dehydration is prevented by fluid resuscitation. Various resuscitation formulas have been used throughout the past decades such as, but currently the most used formula is the Parkland formula, which is defined as the following:

$$4ml \times TBSA (\%) \times body \ weight (kg)$$

50 percent of the total calculated fluid will be administered within the first eight hours and the remaining 50 percent is given in next 16 hours. Urine output and heart rate are the primary methods for monitoring fluids and is the current standards for monitoring fluid therapy in patients. The American Burn Association Practice Guidelines for Burn Shock Resuscitation recommend 0.5 mL/kg/hr urine output in adults and 0.5–1.0 mL/kg/hr in children weighing 30 kilograms. Lesser hourly urinary outputs in the first 48 hours post burn tend to represent inadequate resuscitation. (Mulholland M., Doherty G [53]).

Hyper-metabolism

Hyper-metabolism describes an increase in metabolic rate when compared to the normal metabolic response. Hyper-metabolism leads to an increase in energy demands. Protein, carbohydrates, and triglycerides may inappropriately become energy sources. Hyper-metabolism occurs when there is a significant or multiple injuries to the body and therefore is a cause for concern within burn patients. Changes to a burn victim's metabolism has been seen more than 12 months after the initial event, which can lead to impaired immune function, decreased wound healing, erosion of lean body mass, and hinders rehabilitative efforts.

Patients with burns greater than 40 percent total body surface area can lose up to 25 percent of their body weight in the first 3 weeks following a burn injury. As hyper-metabolism can lead to doubling of the normal resting energy expenditure, enteral nutrition should be started as soon as resuscitation is underway with a feeding tube. Patients with burns over 20 percent TBSA will be unable to meet their nutritional needs with oral intake alone. Patients fed early have significantly enhanced wound healing and shorter hospital stays (Mulholland M., Doherty G [53]).

Infections

As previously mentioned, the skin serves multiply purposes for the human body, including being the first line of defense when protecting the human body from infections and diseases. With the different layers of skin, bacteria is kept from entering the body and when skin is destroyed by burns, the body loses its natural barrier against infections and bacteria. This can become a fatal threat to a patient. Until burn wound is completely healed, the risk of infection is present and needs to be taken into consideration.

Three important factors to consider with infections are the source of organisms, the modes of transmission and the susceptibility of the patient. Organisms associated with infections in burn patients include gram-positive/negative and yeast/fungal organisms. Gram-negative organisms have been known to cause serious infections in burn patients and have been associated with a 50 percent increase in predicted mortality for patients with bacteremia compared to those without bacteremia. This is compared to gram-negative bacteremia, in which there is no increase in predicted mortality. Fungal organisms have also been associated with serious infection in burn patients.

The modes of transmission can include contact, droplet, and airborne spread. Typically with burn patients, direct or indirect contact are the most common of bacteria transmission due to contact with the personnel caring for the patient or contact with contaminated equipment. Not only are burn patients more vulnerable and probable to colonization from organisms in the environment, but they're also known for their tendency to emit organisms into the surrounding environment. The larger and deeper the burn, the more susceptible the patient is to colonization of organisms, as well as the discharge of organisms. Human's principle defenses against infections are the skin, as well as immune responses, such as white blood cells. Changes in these

defenses will cause the patient to be more vulnerable to infections. (Mulholland M., Doherty G [53]).

Infection is a leading cause of mortality in the burn patient and remains a tough challenge for medical personnel to deal with. Typical methods for preventing infections include strict aseptic technique, the use of sterile gloves and dressing materials, wearing mask for dressing changes, and special separation of patients.

To prevent infections, topical medications, such as silver sulfadiazine, and antibiotics are used. Sometimes severe burns are treated by putting the patient into a sterile environment. These sterile environments tend to be rooms filled with pure oxygen under high pressure. However the patient must receive this treatment within 24 hours of being burned for the treatment to be effective. The burned areas are cleaned and covered with an antibiotic cream, then covered in sterile bandages. These bandages are changed frequently and the burned area is carefully monitored for signs of infection. Potential signs of infection include:

- Pain
- Redness
- Swelling
- Heat
- Change in color of burnt area and surrounding skin
- Change in thickness of the burn
- Fever

With infections being the leading cause in morbidity and mortality in burn patients, pneumonia is the main infection. According to PubMed Health, pneumonia is a respiratory condition in which there is an infection of the lung. According to the National Burn Repository

(American Burn Association [9]), pneumonia was the most frequent clinically related complication and occurs in 4.5 percent of fire/flame injured patients. Symptoms of Pneumonia include:

- Fever
- Chills
- Cough with sputum production
- Chest pain
- Shortness of breath

The occurrence of pneumonia and respiratory failure greatly increase with 4 days or more of mechanical ventilation. Prevention of pneumonia is very important.

2.4.3 Debridement

The purpose of debriding is to remove necrotic tissue and metabolic waste from a wound. This is essential to improve and accelerate the healing process, prevent infections and allow a practitioner to better visualize the wound. When the non-living tissue is not removed, protein loss (through large open wounds), generalized infection, limb amputation, or even death may result. Lack of oxygen and nutrients in dead tissue prevents a wound from healing, and may mask underlying abscesses and fluids, as well as serves as a breeding ground for bacteria.

The physician or nurse will begin the debridement process by assessing the patient and decide whether or not debridement is actually needed. The wound will be examined to estimate the depth of dead tissue and evaluate whether it lies close to other organs, bone, or important body features. It is possible that underlying tendons, blood vessels or other structures may be damaged during the examination of the wound and during surgical debridement. Surface bacteria may also be introduced deeper into the body, causing infection (Wound Debridement - Information, Symptoms and Treatment Bupa UK [5]).

The assessment addresses the following points:

- The nature of the necrotic tissue and the best debridement procedure to follow
- The risk of spreading infection and the use of antibiotics
- The presence of underlying medical conditions causing the wound
- The extent of ischemia in the wound tissues
- The location of the wound in the body
- The type of pain management to be used during the procedure

Conventional debridement techniques include surgical, mechanical, chemical, and autolytic debridement (SurgeryEncyclopedia. [65]). Besides those methods, there are novel approaches to burn wound, such as low frequency ultrasonic debridement and Versajet hydro-surgery. They will be described in detail further in this chapter.

Table 3- Top Ten Burn Treatment Procedures [20-20.9 Years of Age] [10]

TOP TEN PROCEDURES		
Top Ten Procedures Codes	Count	% of All Procedures
86.22 Excisional debridement of wound, infection, or burn	8,116	16.0
86.69 Other skin graft to other sites	4,987	10.4
86.28 Nonexcisional debridement of wound, infection or burn	2,724	5.7
86.66 Homograft to skin	2,258	4.7
93.57 Application of other wound dressing	1,819	3.8
38.93 Venous catheterization, not elsewhere	1,509	3.2
86.65 Heterograft to skin	1,102	2.3
86.67 Dermal regenerative graft	1,035	2.2
99.29 Injection or infusion of other therapeutic or prophylactic substance	1,024	2.1
86.62 Other skin graft to hand	988	2.1
Total N = 19,033		

Comparing percentage of different burn treatment procedures among different age groups, as shown in **Table 3**, it is observed that excisional debridement plays major role in burn treatment.

Table 4- Top Ten Burn Treatment procedures for Age group of 80+ years [10]

TOP TEN PROCEDURES		
Top Ten Procedures Codes	Count	% of All Procedures
86.22 Excisional debridement of wound, infection, or burn	1,578	13.9
86.69 Other skin graft to other sites	1,082	9.6
38.93 Venous catheterization, not elsewhere	646	5.7
86.66 Homograft to skin	450	3.0
99.29 Injection or infusion of other therapeutic or prophylactic substance	383	3.4
87.03 Computerized axial tomography of head	350	3.1
99.04 Transfusion of packed cells	308	2.7
86.28 Nonexcisional debridement of wound, infection or burn	285	2.5
38.91 Arterial catheterization	274	2.4
96.04 Insertion of endotracheal tube	251	2.2
Total N = 3,594		

As **Figure 27** shows that almost half of all burns only covers 0.1-9.9% of the total body surface area. However, there are still a lot of burns of greater TBSA, in which the mortality rate increases rapidly in proportion to the burn area, as shown in **Figure 28**.

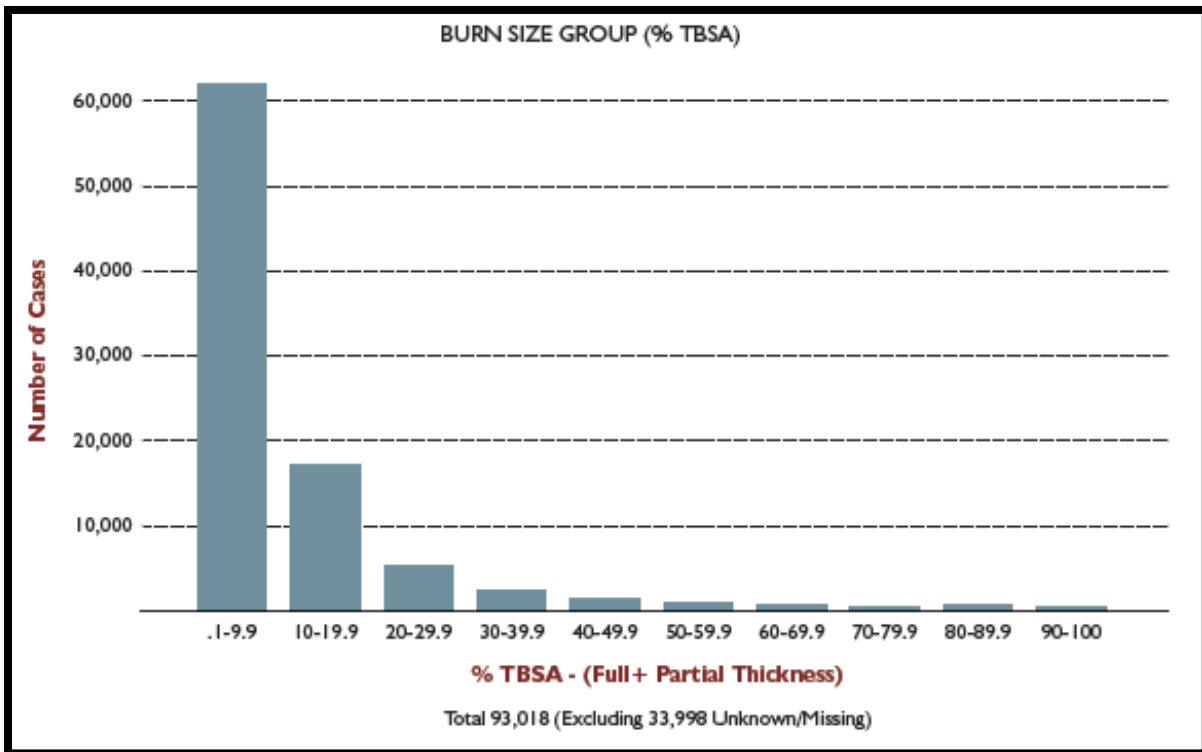

Figure 27- Burn Size Group [10]

LIVED/DIED BY BURN GROUP SIZE (%TBSA)

%TBSA	Lived	Died	Mortality Rate
	No. of Cases	No. of Cases	
0.1 - 9.9	62,113	403	0.6
10 - 19.9	17,064	518	2.9
20 - 29.9	5,267	473	8.2
30 - 39.9	2,277	419	15.5
40 - 49.9	1,093	352	24.4
50 - 59.9	596	336	36.1
60 - 69.9	398	297	42.7
70 - 79.9	215	289	57.3
80 - 89.9	128	286	69.1
> 90	97	397	80.4
Subtotal	89,248	3,770	4.1
Missing or 0%	32,737	1,261	3.7
TOTAL	121,985	5,031	4.0

Total N= 127,016

Figure 28- Lived/Died by Burn Group Size (%TBSA) [10]

Conventional Debridement Methods

Surgical Debridement

This technique, also known as sharp debridement, utilizes various surgical instruments such as Goulian/Weck, Watson dermatomes (hand held surgical knives), scalpels, scissors, etc to remove necrotic tissue from a wound. This method is used best on wounds with large amounts of necrotic or infected tissue (Ronald Sherman [61]). **Figure 29** shows the Goulian Surgical Knife, a surgical tool used in the mechanical debridement surgeries.

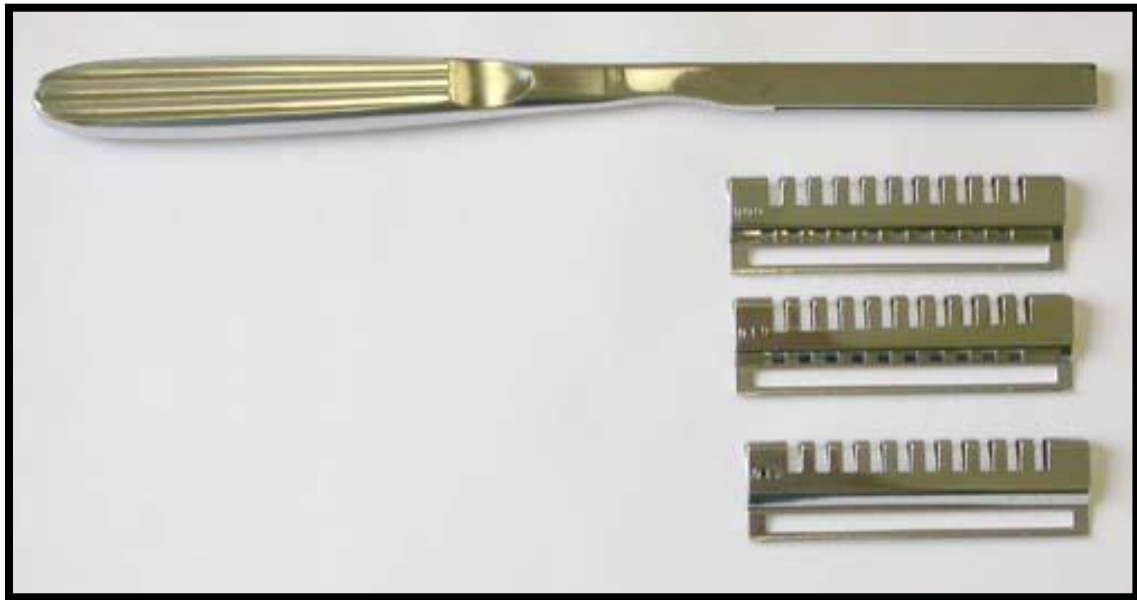

Figure 29- Goulian Surgical Knife [61]

This procedure is used when the surgeon is faced with a time sensitive operation such as a rapidly developing inflammation or a spreading infection in the bloodstream. This current standard of wound debridement is very fast and effective. The physician starts by flushing the area with a saline (salt water) solution, and then applies a topical anesthetic gel to the edges of the wound to minimize pain. Using tongs to grip the dead tissue, the physician cuts away bit by bit with a scalpel or scissors. Sometimes it is necessary to leave some dead tissue behind rather

than disturb living tissue. The physician may repeat the process again at another session. The spread of a third degree burn can an extensive amount of damage, and all the dead tissue may not be removed all in one surgery. Although this method is extremely effective, it is costly. This method may put a patient under substantial pain and might be often imprecise or result in excessive tissue removal. This technique is also not suited for debridement of such areas as eyelids, ears and web spaces.

Mechanical Debridement

Mechanical debridement is one of the oldest methods of debridement. It is a low costing operation and is suitable for wounds with moderate amounts of necrotic tissue. This type of debridement procedure starts with applying a saline-moistened dressing on a wound, then letting it dry and removing it with the debris and necrotic tissue. However, it is non-selective and may be very painful as it can remove living as well as necrotic tissue (Ronald Sherman [61]).

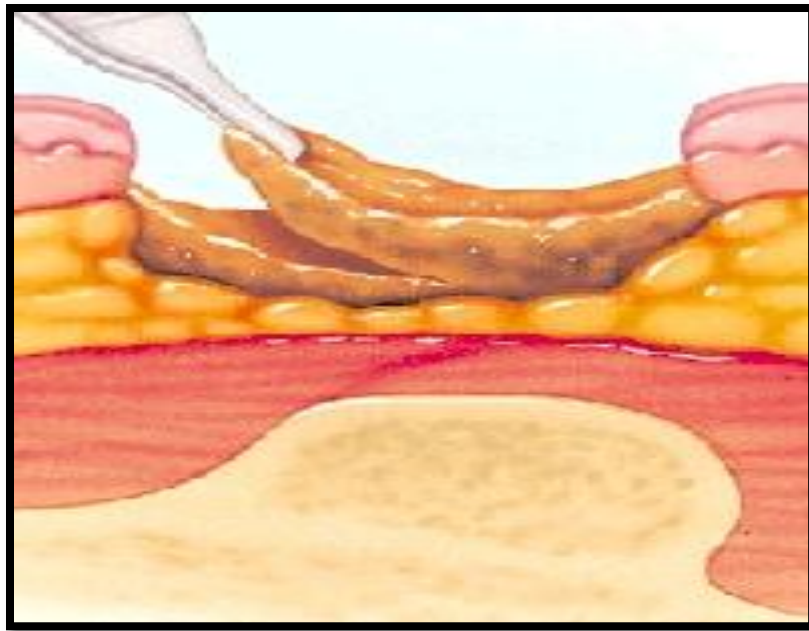

Figure 30 - Mechanical Debridement [61]

Figure 30 depicts a mechanical debridement method, where the necrotic skin is being removed. This method is unacceptable for debriding clean wounds where a new layer of healing cells is already developing.

Chemical Debridement

Chemical debridement makes use of certain enzymes and other compounds to dissolve necrotic tissue. The body makes its own enzyme, collagenase. A pharmaceutical version of collagenase is available and is highly effective as a debridement agent. As with other debridement techniques, the area first is flushed with saline. Any crust of dead tissue is etched in a crosshatched pattern to allow the enzyme to penetrate. A topical antibiotic is also applied to prevent introducing infection into the bloodstream. A moist dressing is then placed over the wound (Ronald Sherman [61]).

Autolytic debridement

Autolytic debridement takes advantage of the body's own ability to dissolve dead tissue. The key to the technique is keeping the wound moist, which can be accomplished with a variety of dressings. Dressings help to trap wound fluid that contains growth factors, enzymes, and immune cells that promote wound healing (Ronald Sherman [61]).

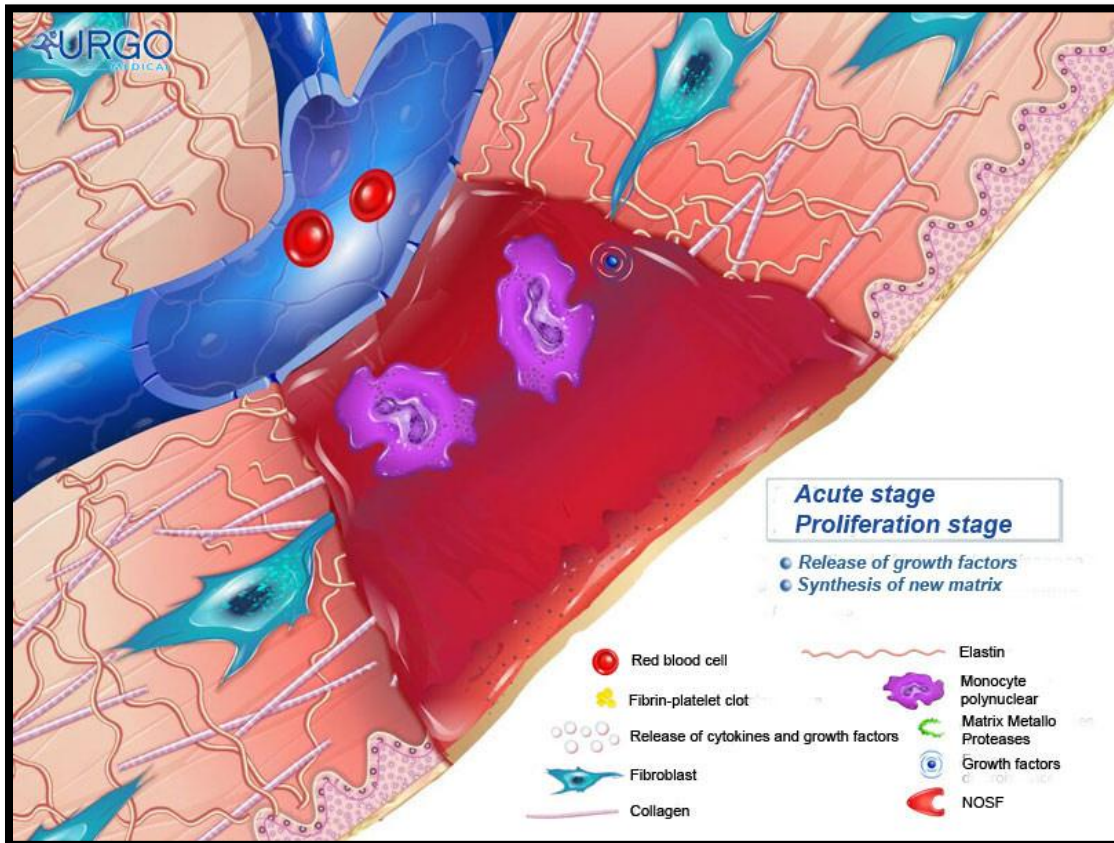

Figure 31 - Autolytic Debridement [65]

Figure 31 depicts the acute and proliferation state of autolytic debridement. Not only is this method selective but it is also safe to surrounding skin, while almost painless and easy to perform. The disadvantage of the method is that it takes the longest to work, needs to be closely monitored for signs of infection and is not inappropriate for wounds that have become infected.

Biological Debridement

Biological debridement most often involves using the larvae of greenbottle fly that are applied to the wound. The organisms digest necrotic tissue and bacteria. This method has been known around for decades. It is a rapid and selective method with little pain, however a lot of patients are reluctant to the procedure for psychological reasons. A study with 21 ambulatory patients has shown that more than 95 percent of the therapists and 90 percent of their patients were satisfied with their outpatient maggot debridement therapy. Of the 8 patients who were advised to undergo amputation or major surgical debridement as an alternative to maggot debridement, only 3 required surgical resection (amputation) after maggot therapy. Maggot therapy completely or significantly debrided 18 (86 percent) of the wounds and 11 healed without any additional surgical procedures.

After surgical debridement, the wound is usually packed with a dry dressing for a day to control bleeding. Moist dressings are applied to promote wound healing after mechanical, chemical, and autolytic debridement. Debridement usually needs to be repeated so the healing process usually takes a long time (Ronald Sherman [61]). Debridement is followed by dressing, which is necessary to keep the wound clean and prevent infection. Commonly used types of burn dressings include collagen dressings, foam dressings and hydrogels (SurgeryEncyclopedia [65]).

2.4.4 Modern Debridement Procedures

Versajet Hydro-surgery System

The Versajet hydro-surgery system, built by the Smith &Nephew Company (United Kingdom) was analyzed as a novel burn debridement tool. The system enables surgeons to precisely select and remove necrotic tissue, bacteria and contaminants from a wound. This handheld device's operation is based on the Venturi effect to create a localized vacuum. It has various power settings, which allow it to remove various amounts of nonviable tissue at a rapid rate, while still preserving as much healthy tissue as possible. Studies have shown evidence of Versajet being an effective device in wound debridement particularly in anatomic areas where conventional debridement is difficult to perform. The device is less efficient in full thickness burns. Lowering the bacterial load has also been observed in burn wounds treated by the device. (C. Cubison [23]). Figure 32 shows the Versajet Hydrosurgery system being used on a burn patient to remove the necrotic skin (C. Cubison [23]).



Figure 32-Versajet Hydro-Surgery System [23]

Several researches that have been held indicate following clinical and economical outcomes:

- Reduced bacterial burden
- Preserves viable tissue
- Removes unwanted necrosis and debris
- Improved graft and synthetic dressing results
- Improved excision of contoured areas, web spaces and facial structures
- Minimized peripheral tissue damage
- Reduced number of debridement
- Reduced healing time, compared to conventional methods
- Reduced operating room time
- Reduced repeat procedures
- Minimized cross contamination
- Reduced treatment cost

A study conducted in 44 patients using Versajet as an adjunct to surgical debridement in a variety of anatomic spaces including eyelids, ears, etc, showed the following that no patients required repeat grafting as a result of inadequate excision with the Versajet. In addition, no patients experienced graft loss due to excessive tissue excision". This adjunct reduces the risk of inadequate debridement and damage to fragile anatomic structures, which is not suitable for debriding large areas.

In the study Granick et Al., 40 patients with 45 wounds debrided with the Versajet system have been compared to 22 control patients with 22 wounds debrided by conventional surgical method. The groups were compared by wound type, diagnosis, age and gender. The mean number of debridement was significantly less for the Versajet group, 1.18 versus 1.91

procedures per wound for control group. Furthermore, significantly lower odds of needing additional procedures were reported among patients of the Versajet group.

Klein et Al. reported a 2000 dollar decrease in average debridement procedures per patient costs that was due to the reduction in the number of procedures per patient in the Versajet group reported by Granick. The price of the Versajet console is 9500 dollars with individual hand piece cost of 355 dollars. Alternatively, Smith & Nephew will provide the console free of charge but the cost per hand piece will be raised to 395 dollar (Klein et al.). Comparing the number of procedures per patient and debridement cost at the University Hospital in Newark, the device proves to be very cost effective (C. Cubison [23]).

Low Frequency Ultrasonic Debridement

Currently, there are several low-frequency (20-120 kHz) ultrasound (LFU) wound therapy devices available in the U.S. Market that are approved by FDA. With proper training these devices may even be used by nurses. Low-frequency ultrasound therapy stimulates the generation of nitric oxide in the endothelium via fluid shear-stress, which in turn, increases blood flow. A study was designed to verify the increase in blood flow (post-ultrasound treatment) of the periwound skin in lower-extremity wounds using the laser-Doppler based Skin Perfusion Pressure (SPP) monitor (Suzuki K., Cowan L., Aronowitz J. [67]).

In order to test this, 17 nonrandomized lower extremity wound patients were selected in two groups according to the type of debridement the patients received, either conventional surgical debridement or 5 minute sessions of low-frequency ultrasound debridement, both followed with saline irrigation. The SPP values were measured at the same location (periwound area) before and after sharp debridement or ultrasound treatment. Studies have shown that low frequency ultrasound debridement is capable of accelerating wound healing with low levels of pain. Ultrasound debridement involves transferring ultrasound vibrations (40 kHz, 0.1 W/cm^2 - 0.5 W/cm^2) to the wound via a stream of ultrasound generated mist from a transducer horn made on titanium alloy. The device was held 5 – 15 millimeters away from the wound. This type of debridement simulates blood flow to the treated wound. As research shows that nine subjects in the ultrasound group showed significant increase in mean = 9.11 mmHg, SD = 4.34 after 5 minutes of ultrasound therapy. For comparison, 8 subjects in the control group mean = 1.2 mmHg, SD = 0.84 group showed negligible increase in SPP.

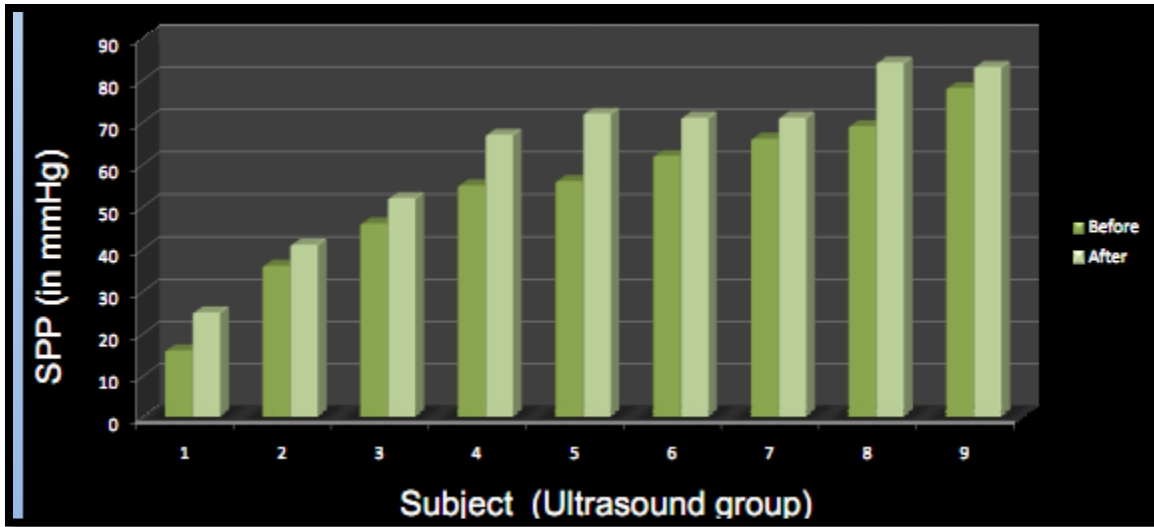

Figure 33-SPP (in mmHg) values for the Ultrasound research groups [68]

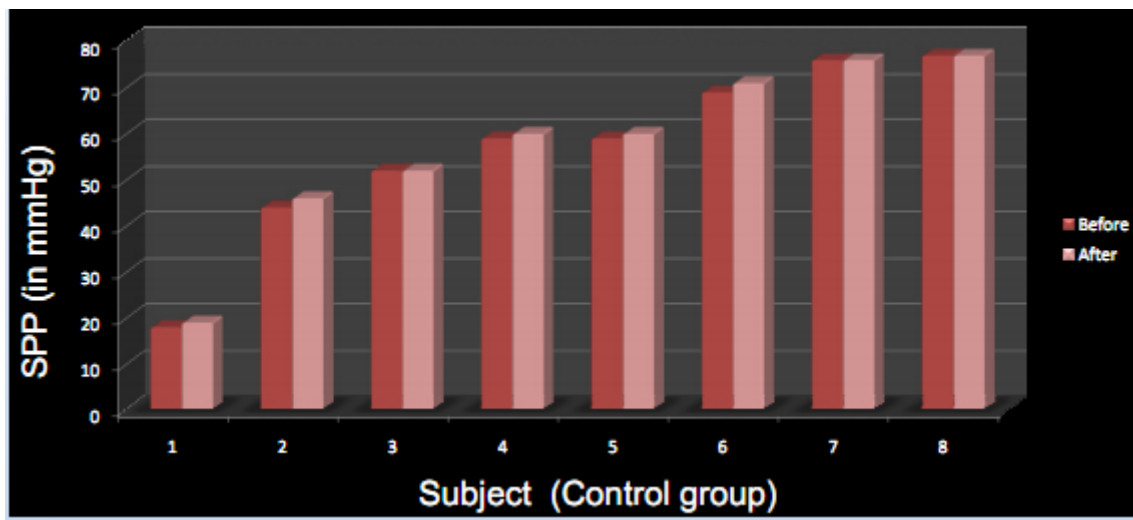

Figure 34- SPP (in mmHg) values for the surgical debridement research groups [68]

Figure 33 and **34** reflects mmHg levels before and after debridement for the ultrasound and the control groups in respect to time. It is clear that patients with wounds that have been debrided with low-frequency ultrasound show a significant change in SPP after the procedure in comparison to the patients treated by the conventional surgical debridement method.

According to studies patients treated with LFU have a significantly shorter average healing time of group (mean: 9.12 ± 0.58 weeks; median: 11 ± 0 weeks) comparing to patients treated with conventional methods (mean: 11.74 ± 0.22 weeks, median: 12 ± 0.82 weeks) (log rank $p < 0.0144$) (Kazu Suzuki [68]).

2.5 Recovery

Despite all of the different factors & challenges that occur in burns, of all the known burn incidences in the United States alone, survival rate is over 90%. **Figure 35** compares burn center mortality rates in fire/flame cases between the years 2005 and 2008. With over 125 established specialized burn centers in the United States in 2005, and the number only increasing, patients in need of special care have been able to receive treatment more efficiently than ever.

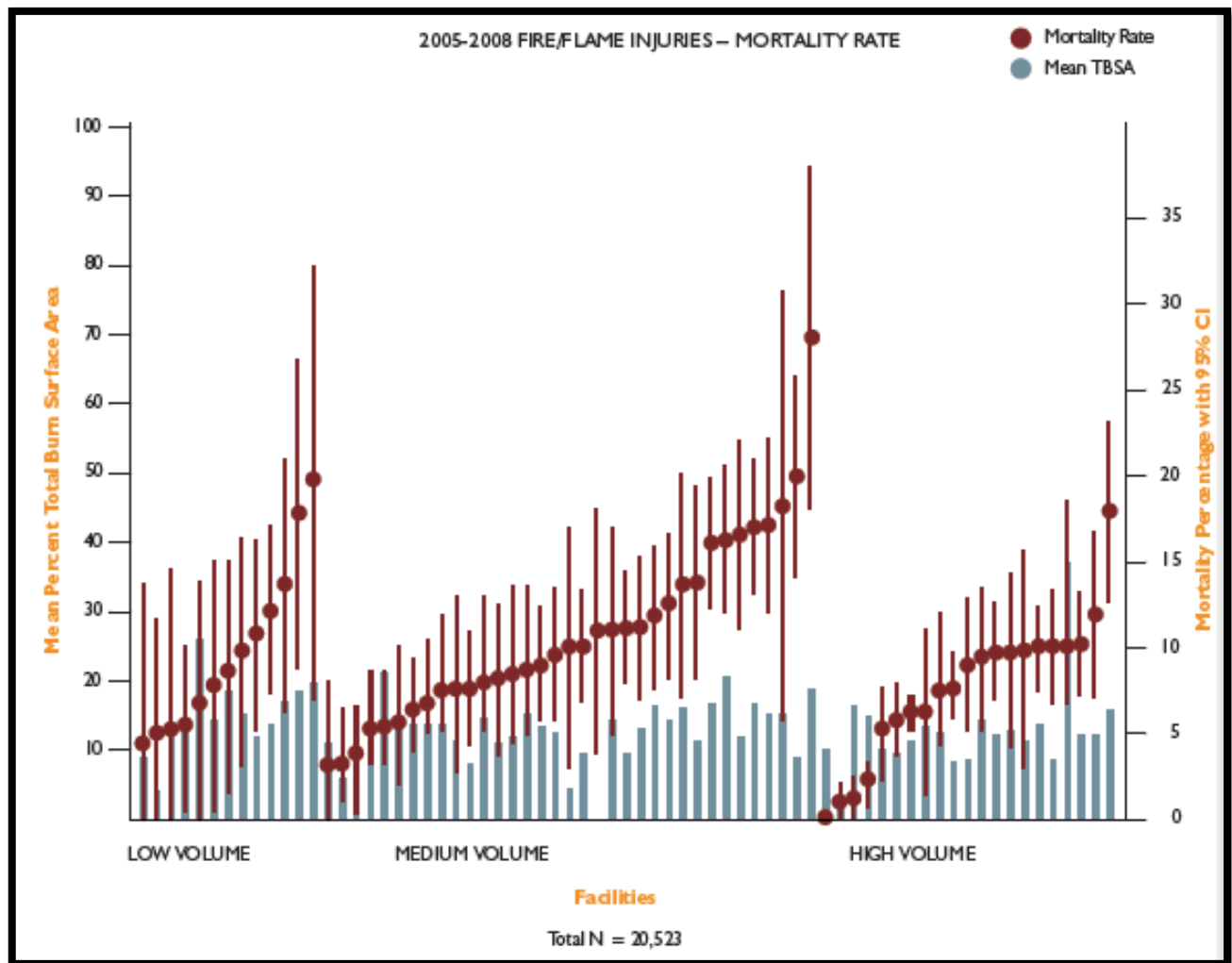

Figure 35- Burn Center Mortality Rates in Fire/Flame Cases [10]

While advancements in technology and information have led to vast improvements in the burn care field, recovery from burns is still a major factor and long-term care for patients admitted into specialized burn centers is always a necessity. There are different factors to consider with the long term burn recovery process such as the length of hospitalization and the length of time the skin takes to completely heal. The length of hospitalization is also affected by other elements including other previous injuries and pre-existing medical problems, which can further complicate the recovery process. There are some issues that burn survivors need to take into consideration is the loss of the ability to sweat, the need for special skin lotions, the change of color and strength of the skin, the changes in feeling in a burned area, and the pain that may occur.

With a deep burn, either an II or III-degree burn, the burn is so extensive that it destroys sweat glands, which are not replaced when the skin starts to heal. Sweat glands are an important part of the human body because sweating is used to control the body temperature, and without the sweat glands, it becomes very difficult for burn survivors to tolerate hot and humid weather conditions. This can become a lethal problem due to the fact that these types of conditions, which include exercising or recreational activities, increase a chance for a person to go into a heat stroke. Watching body temperature and remaining hydrated becomes vital for a burn survivor. Not only are there glands in the skin that provide the means for sweating, but there are the sebaceous glands that produce oils that lubricates and moistens the skin, preventing skin from becoming too dry and cracking. When these glands are destroyed, proper lotion application is another habit that burn survivors need to become accustomed too (American Burn Association [10]).

Figure 36 compares mean hospital length of stay for fire/flame cases between 2005 and 2008.

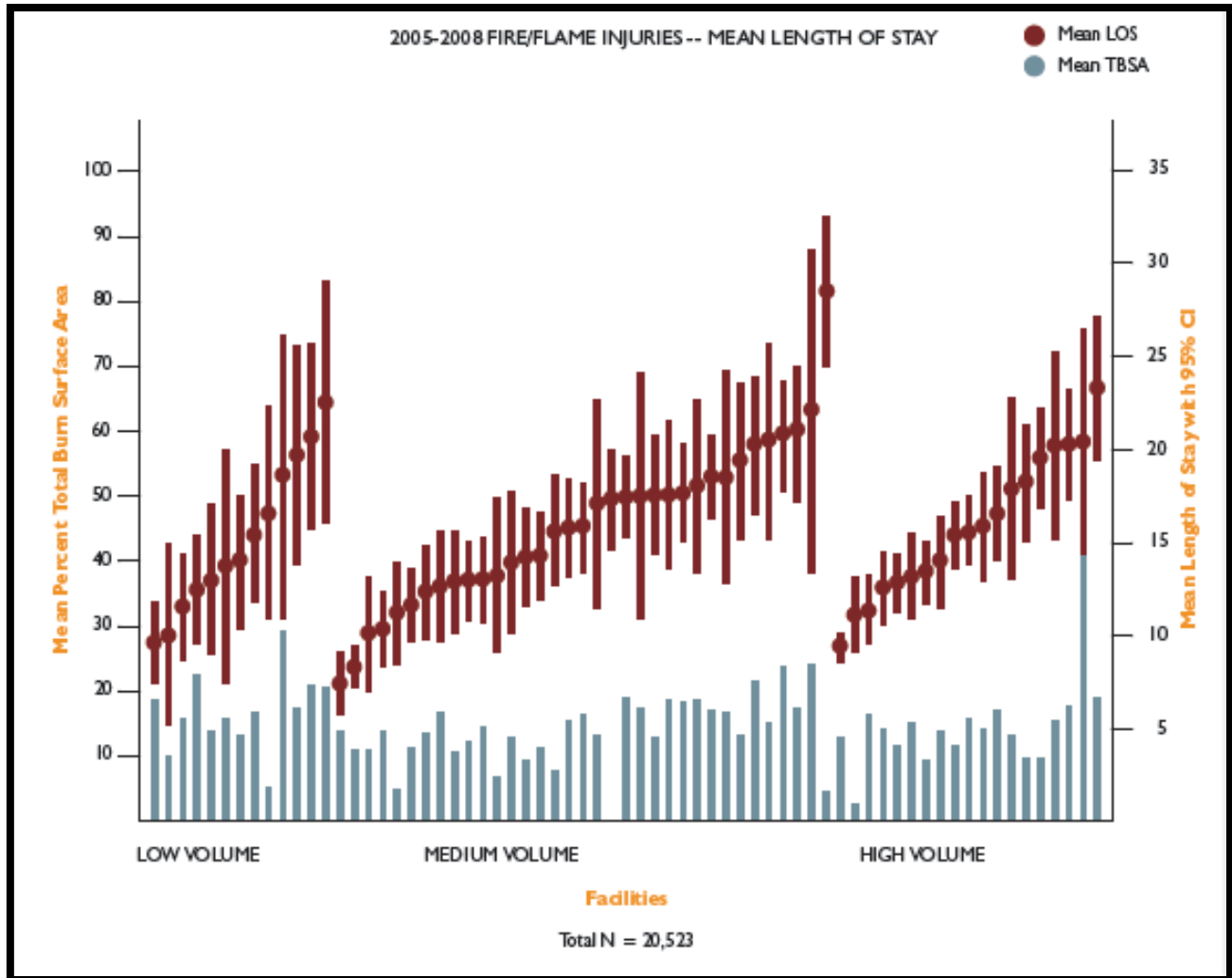

Figure 36- Mean Hospital length of stay for fire/flame cases between 2005-2008 [10]

When recoveries from a typical burn, the skin tends not to be the same as it was before. Color of the skin can also change following burns. During the natural process, skin color is created by cells in the epidermis of the skin called melanocytes, which produce melanin. This pigment melanin is responsible for the different skin colors that we see and when someone suffers from a deep burn that affects the epidermis, the melanocytes are destroyed. Strength of

the skin is also another attribute of the skin that changes with deep burns. It is said that healed burned areas are about 20% weaker than the skin that was replaced. The skin is even weaker during the recovery process and prone to blistering. Special care and attention needs to be placed on burn areas, which include wearing appropriate clothing, keeping burned areas away from possible sun burns, and watching for allergic reactions that may affect the skin. Change in sensation or feel is another effect a burn can have on skin and the degree and depth of the burn will dictate the amount of sensation that the skin will have. While for a superficial burn, sensation may return to normal after the wound has healed, for deeper burns, feeling is often diminished. This can include sensation of hot and cold, and touch. There is a trend of heightened sensitivity to air temperature, most feeling more sensitive to colder air temperatures. Pain is the last and greatest effect that a burn will have throughout the burn recovery phase.

With burn care, there is a natural regenerative path to a burn recovery, and you also have the more unnatural surgical way. These different methods are described in 3 different categories of wound closure. The 3 categories of wound closure are primary intention, secondary intention, and tertiary intention. Primary healing occurs when a wound will close within hours of its creation. Secondary healing involves no formal wound closure but instead the wound closes spontaneously by contraction and the re-growth of skin tissue over a denuded surface. Tertiary wound closure, also known as delayed primary closure, and involves initial debridement of the wound and then formal closure with suturing or by other methods.

In general, there are three phases in regards to skin healing, known as inflammation, tissue formation also called proliferative, and tissue remodeling. The first phase, inflammation, tends to last roughly a week and the body begins a process to remove dying or dead skin tissue. The body will also fight the infections that the body may encounter while sending cells to begin

the healing process in burned and infected areas. The second phase, which lasts anywhere between two to five weeks, the body makes collagen fibers that evolves into scar tissue and creates new blood vessels. The third and last phase, which can take months to even years, the scar tissue matures, resulting in a stronger scar and skin tissue. The three phases are aided by surgery and debridement of the dead skin, with replacements with skin grafts. Recovering from a burn injury can be a very long and extensive process that can become very costly. Due to all of the complications and risk included, maximum care and attention is needed to tend to an injury, but with increasing aid, recovery rates have been on the decrease. **Figure 37** depicts the recovery process along with time durations.

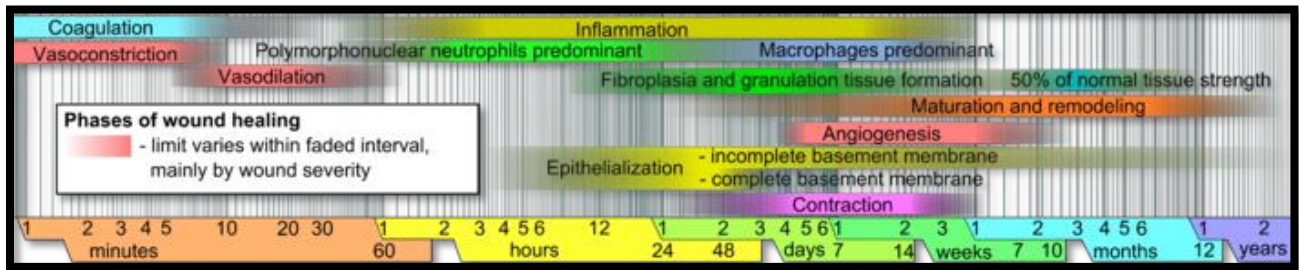

Figure 37- Phases of Wound Recovery [9]

CHAPTER 3. INNOVATION

3. Introduction

In order to create our own debridement procedure, there are several topics that we need to research and investigate. We have already looked into the area of burns and what it takes in order to treat a burn. Taking that knowledge, the group wants to take this better understanding of treating burns and develop a semi-autonomous method in removing the burnt skin from a victim. The next few sections will describe research done in order to achieve our goal of creating a novel technique using current methods & current technology, such as Sony's Aibo, a robotic pet dog that is shown in **Figure 38**.



Figure 38- Sony's Aibo, The Robo-Dog [74]

3.1 Modern Robotic Technology

3.1.1 Robots

Over the past 20th century, there has been tremendous progress in the area of technology and we as humans have been able to integrate more and more technology into our everyday lives. It is apparent the amount of change technology has brought in the manufacturing field, including manufacturing of vehicles, toys, and other consumer goods by streamlining and speeding up the assembly line. There has even been integration of more advanced technology into our own homes, including smart refrigerators and autonomous vacuums and pets. There has also been an increase in interest of creating artificial intelligence, such as Honda's ASIMO robot, which continues to come closer to mimicking human form. While this is just the start of what promises to be a very bright and vivid future for technology advancements, we are already seeing the integration occur in many different fields. Such integration has been brought into the medical field as well. Technology advancements in different fields bring numerous amounts of advantages and benefits, while the level of robotic involvement that should be involved is always a debatable topic. An example of this advancement is the robotic vacuum, shown in **Figure 39**.



Figure 39- Robotic Vacuum, Roomba [74]

3.1.2 Robots in the Medical Field

Over the past decades, we've seen robots replace the humans where people have seen fit, including manufacturing lines, military operations, and many other situations. We're also starting to see the integration of robotics in the medical field, and robotic surgery is already a reality with doctors using very sophisticated robots to perform surgical procedures on patients. Advancements in this field are in large part due to the military. The military needs to provide a way for doctors to help injured soldiers on the battlefields without having to physically be there and put themselves at risk. While currently it has been difficult to integrate the technology into modern day militaries, due largely in part to latency issues, civilian doctors and hospitals have been able to take the technology and use it themselves.



Figure 40- Military Robots [74]

An example of a robot in the military is shown in **Figure 40**, as the robot is fitted with a machine gun to be able to attack the enemies without risking human lives.

We've been seeing more and more of this integration of technology and currently there are three different kinds of robotic surgery systems. The three levels of robotic assistance are called supervisory controlled systems, telesurgical systems, and shared-control systems, which differ by how involved a human surgeon must be when performing a surgical procedure. The more advanced technology allows the robots to perform surgical procedures without any direct intervention of a surgeon, while there are a range of machines where doctors will perform the surgery with the assistance of a robot.



Figure 41- HONDA's Asimo Robot [74]

Supervisory controlled System

In a supervisory controlled system, the procedure is executed solely by the robot. The robot is programmed prior to the procedure with a computer code or program inputted by the medical staff. While the medical staff will not participate in the medical procedure directly, the staff is still vital in planning the procedure and overseeing the procedure. Typically, there must be extensive pre-operation preparation done before the robot can operate. Because the program is inputted before the robot performs surgery, there is no room for error as the robot itself will not be able to adjust mid-surgery. A popular reason to use this method is that this can make a surgery process very precise which in turn can reduce trauma on a patient and reduce recovery time. But this can become very expensive process since the robot performs and the entire procedure and must be constantly programmed for each individually medical procedure (How Stuff Works [75]).



Figure 42- RoboDoc Surgical System [59]

The RoboDoc (RoboDoc [59]) is an example of a supervisory controlled system used in orthopedic surgeries. A Surgeon positions the RoboDoc's bone-milling tool inside the patient and the robot will cut the bone to the precise measurement in order to install the orthopedic implant.

Telesurgical Systems

The telesurgical system is also known as the remote system, which requires the medical staff to operate the robotic machine during the procedure instead of having a fully autonomous machine run a pre-determined program. The surgeons tend to operate robotic arms that act as their own and allow for very high precision. Real-time imaging feedback is used, allowing the surgeon to use the machine from a remote location using data transmitted from the machine (How Stuff Works [75]).

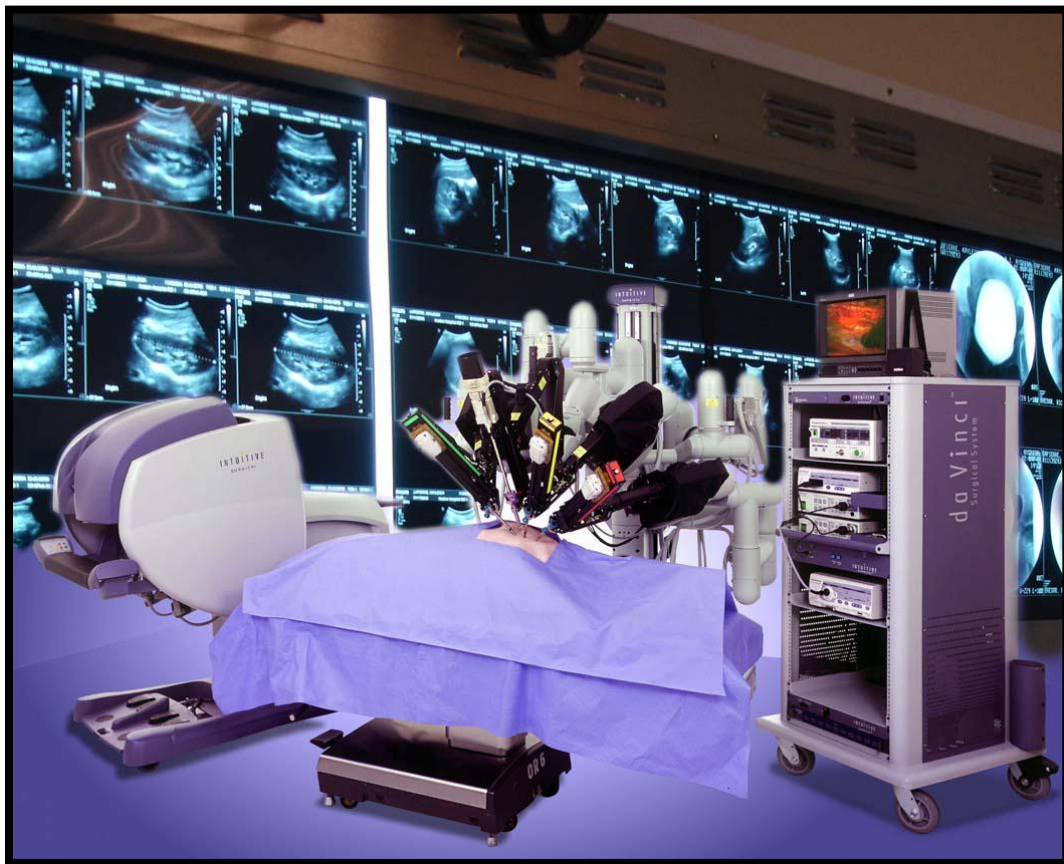

Figure 43- Da Vinci System [75]

Figure 43 is a picture of the Da Vinci Surgical system in an operating room. The Da Vinci surgical system is the leading product in this system, using advanced technology to enable surgeons to perform complex and precise operations through small incisions with increased

vision, precisions, dexterity and control. The Da Vinci Surgical system is comprised of several components including an ergonomically designed console where the surgeon sits while operating, a patient side cart where the patient lays during surgery, four interactive robotic arms, a high definition 3D vision system and trademarked EndoWrist instruments.

Shared-control System

The shared-control system features the most medical staff involvement. The staff carries out the procedure with the use of a robot that just offers steady-hand manipulations of the instrument, which enables both sides to perform the procedure. The robotic system monitors the surgeon's performance and provides stability and support through what's called active constraint. Active constraint relies on four main categories, and recognizing these regions on a patient. The four categories are safe, close, boundary, and forbidden. The safe regions are the main focus of a surgery. This defining of regions is done through pre-operation planning done by the surgeons.

Figure 44 is an image of a nurse adjusting an EndoWrist (How Stuff Works [75]).



Figure 44- Nurse preparing a robotic surgery system [75]

3.2 Design Iterations

3.2.1 Introduction

The new debridement device has the following objectives:

- To provide an effective method of burn wound cleaning
- Automate the process of cleaning a burn wound
- Decrease possibility of human error
- Decrease the risk of an infection
- Decrease pain level of the burn wound cleaning procedure
- Decrease patient recovery period

The team's goal is to design a highly precise robotic surgery system for performing minimally invasive surgeries for an extended amount of time, minimizing infection risks. The team had several design ideas that were analyzed in order to select the most appropriate and feasible approach. Originally the design involved placing a patient into a chamber with a rotary table, much like those in the magnetic resonance imaging, also known as MRI. The design also involved a robotic arm similar to those in Computer Numerical Control Milling Machines. A patient would be under local or general anesthesia, while the table would rotate accordingly to a programmed algorithm, as the robotic arm would simultaneously assess and debride the wound. As research has shown, programming table rotation algorithms is a highly sophisticated process. So, since the table will need to constantly receive the input from a depth assessment device and adjust accordingly this design idea did not seem feasible because of its complexity. Furthermore, there is a need for prior and simultaneous burn geometry as well as depth assessment. The project team analyzed most effective depth assessment device currently available – Laser Doppler Blood Flowmetry Imager. The research has shown that despite the high assessment speed of the imager still is not sufficient to perform debridement with precision as the image

processing takes 1-3 minutes. As a result, the design idea with a rotary table is eliminated. The design idea with autonomous burn depth assessment is eliminated as well. This left us to having burn geometry and depth assessment performed by a surgeon. Our goal is to be able to perform surgeries for an extended amount of time and lower human errors. We also want to lower surgeon's fatigue, because the fatigue of the surgeon may lead to potential hand tremors during a surgery. The most effective approach is to have the surgeon sitting and perform the surgery from a distance, which brings a need for a communication system between the debriding device and the surgeon. A camera would be installed on the end of the device to let the surgeon monitor the process. During the research the team has been able to analyze the operation of a robotic surgery system named "Da Vinci Surgical System". The system implements technology we need to meet our design objectives. The system has a high definition camera needed to observe and assess a wound, robotic arms that are controlled by a surgeon and that have a calibrating system to eliminate human hand tremors. In order to complete the objectives of decreasing risk infections and reducing pain, the group has designed a specialized debriding nozzle with disposable and reusable parts with multiple power settings.

Further sections of **Chapter 3.2 Design Iterations** contain detail on advantages and disadvantages of original design ideas, the reasoning for selecting our final design and the design description.

3.2.2 Supervisory Controlled System

Computer Numerical Control Milling Machines

Milling machine is a tool used machine solid materials. There are two basic types of milling machines - vertical and horizontal, classified by the orientation of the main spindle. Both types may vary from small bench mounted to room-sized machines. Ability to move the work piece is what makes milling machines different from other types of machines. Work piece and cutter movement may be adjusted to very precise values of less than 0.025 millimeter. Adjustment may be manual, mechanical or digital via computer numerical control (CNC). As a potential base for a design, horizontal rotary table CNC mill architecture was analyzed. This type of a mill allows milling at various angles. **Figure 45** is a picture of a CNC milling machine.



Figure 45- Computer Numerical Control Milling Machine [71]

Horizontal CNC machines have C, Q and B axis in addition to the normal X, Y and Z axis. When these axis are used in conjunction with each other, extremely complicated geometries can be made with the machines. However, the skill to program such geometries is beyond that of most operators. Conducting autonomous robotic debridement will need initial input based on burn wound geometry. Continuous adjustment in accordance to burn assessment data will be needed. These factors make the use of horizontal CNC milling machine prototype design unreliable and therefore should not be used in the design. **Figure 46** is a photograph of a rotary table for a CNC milling machine with rotating table and computer interface.



Figure 46 - Five-Axis Machining Center [71]

Laser Doppler Blood Flow Assessment Imager

Laser Doppler Imaging is the most reliable burn depth assessment method with accuracy of 90-100 percent. It has a frame rate of 1.48 hertz and a relatively high spatial resolution of 290 μm . However to acquire an acceptable estimation of a burn depth it is necessary to collect at least three minutes of imaging and image post-processing takes one to two minutes. **Figure 47** is an example of laser Doppler blood flow assessment of a brain including stimulus, image post-processing and the resulting functional image.

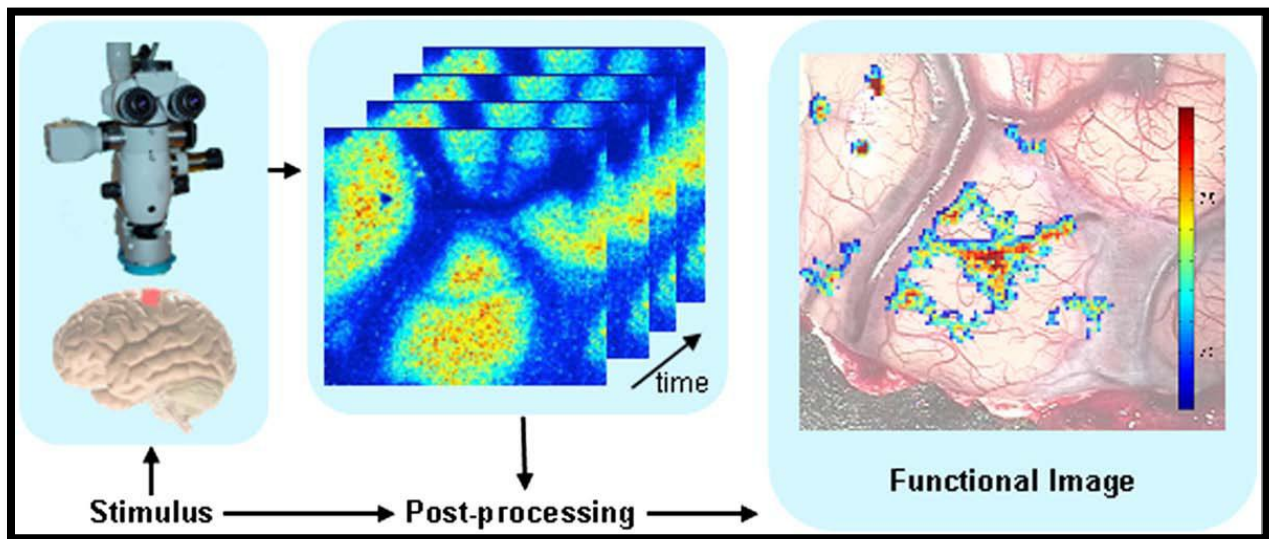

Figure 47 - Laser Doppler Blood Flow Imaging of a Human Brain [72]

That is an insufficient period of time for simultaneous debridement and burn depth assessment. Debridement tool needs to get constant and most up-to-date condition of the burn in order to avoid removing any living tissue and cause more damage to the wound. Furthermore, as has been previously mentioned in on Burn Assessment, this technology requires close contact with the wound, which increases infection risks. Rapid laser Doppler blood flow assessment instruments are very expensive. In addition to all these factors LD imagers are usually only available in specialized burn centers due to a very high cost of the equipment. The disadvantages

of this very accurate burn depth assessment method results in its elimination as a mean of assessing burn simultaneous to the debridement process.

3.2.3 Telesurgical System Implementation Design Options

As has been mentioned before in section the Innovation Research, one of the most advanced robotic surgical systems that receive all of its inputs solely from the surgeons is the Da Vinci Surgical System. A surgeon sits at a control console a few feet away from the operating table. Observations are made through a three-dimensional enhanced high definition camera with the maximum magnification factor of 15. The camera sends images to a monitor inside the control console for the surgeon to be able to observe the operation of the robotic arms. Surgical instruments manipulation performed with a use of joystick-like control rings underneath the monitor, as shown in **Figure 48**.



Figure 48-Da Vinci Surgical System Control Console [73]

In **Figure 49** is the control console of the Da Vinci surgical system. The monitor is inside the console. The surgeon inserts his fingers in the rings that send corresponding signals to the robot's arms. This surgical system has offers motion scaling, so that gross hand movements are transformed into fine movements allowing minimizing invasiveness of a surgery and maximizing its preciseness.



Figure 49 - Da Vinci Surgical System Control Console [73]

Figure 50 is the picture of the joy-stick like game control. Fingers are inserted into the control rings and their motion is scaled and tremors reduced.



Figure 50 - Da Vinci Surgical System Control Rings [73]

For an example, surgeon's one inch movement gets translated to robot's quarter inch movement. The device also offers control using a single foot pedal that provides device engagement and disengagement. As the foot pedal is released the surgeon can relax and reposition (center and re-index) his hands and arms. The arms use a technology called EndoWrist — flexible wrists that surgeons can bend and twist like human wrists. EndoWrist, instruments are made by Intuitive Surgical and they are electromechanical arms representing surgeon's right and left arms that provide mechanical capability to perform complex tissue manipulations. They are designed to provide a full range of motion and very precise operation in minimally invasive surgeries.

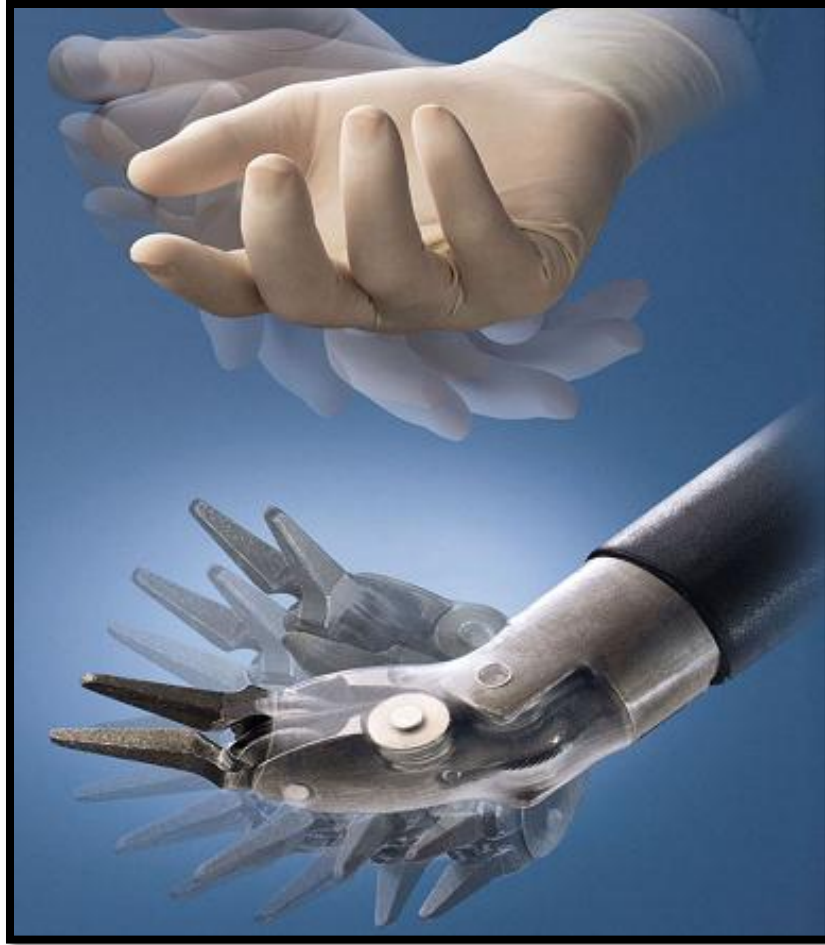

Figure 51 - Da Vinci Surgical System EndoWrist [73]

Figure 51 shows the EndoWrist dexterity and flexibility which is modeled after a human wrist. The instrument offers even a greater range of motion, greater surgical precision, high responsiveness that allows very rapid manipulation EndoWrist offer 7 degrees of freedom, 90 degrees of articulation as well as motion scaling and tremor reduction.



Figure 52 - Da Vinci EndoWrist Specialized Tip [73]

Intuitive Instruments provide a wide selection of EndoWrist specialized tip designs to perform various types of surgical procedures as shown in **Figure 52**. EndoWrist tips are approximately 5-8mm in diameter. The surgeon uses hand movements and foot pedals to control the camera, adjust focus, and reposition the robotic arms. The entire layout of a typical surgery room including the Da Vinci system is shown in **Figure 53**. This serves to give us a better understanding of how the system is set up and how a patient would be operated on.

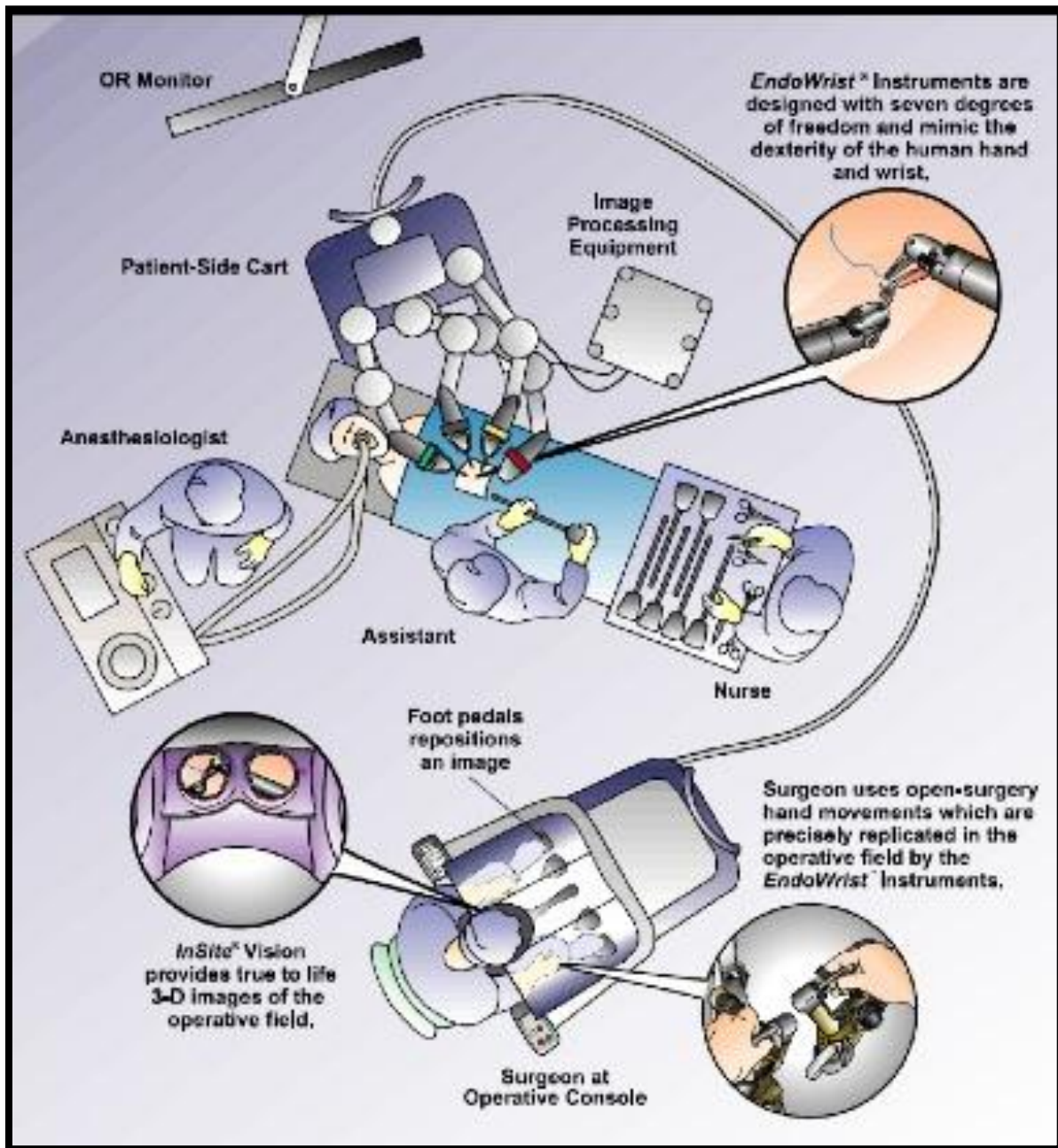

Figure 53 - Da Vinci Surgical System in General Procedure Setting [73]

3.3 Debriding Device Final Design

After evaluating the different methods and procedures currently used to debride necrotic skin from a burn patient, we were able to develop our own preliminary design that would be able to perform the same operations. The debridement design can be broken up into three main components, the first being a robotic arm, the second being a vacuum like nozzle, and the last component is a railway system that the robotic arm rests on. The robotic arm is designed to be able to rotate and move in every quadrant allowing access to any point on an x, y, and z plane. To provide additional movement along the y plane, the machine will be placed on a moving railway system. All movements of the robotic arm and nozzle tip will be controlled by a surgeon on a control system. This includes the control of the moving railway system, different rotations and movements of the robotic arm, as well as the rotation and power of the nozzle. The nozzle will be placed at the end of the robotic arm and will simultaneously debride and collect removed tissue. The nozzle should include a high definition camera to provide a better view of the surgery, as well as a screen for the surgeon be able to view the live feed from the camera. The arm will have two points of rotation providing greater dexterity. Main purpose of the console is to provide the connection between the surgeon and the robotic arm. The surgeon should be able to manipulate the arm from a distance, while the robotic arm mimics the exact control of the surgeon. The device design takes into consideration various burn depth and therefore implements several power settings to control the intensity of debris removal, including most gentle cleaning to decrease pain levels as much as possible. In order to meet the decreasing of infection risks objective the device will be using disposable tubing and steel nozzles that can be reused multiple times after vigorous sterilization.

3.3.1 Arm

The arm is attached to a rail located on the ceiling of a chamber or room. The robotic arm has three points of rotation. The point closest to the ceiling has an axis of 360 on the x and y plane. The second point closest to the nozzle has movement on the x, y, and z plane. Attached to these joints are a series of chains which allow for motion of the arm. The arm is controlled by an operator via computer console controls. Remote control surgery was chosen to avoid any hand tremors a surgeon may experience during an extensive debridement. CAD Models and a CAD are given in **Figure 54** and **55**.

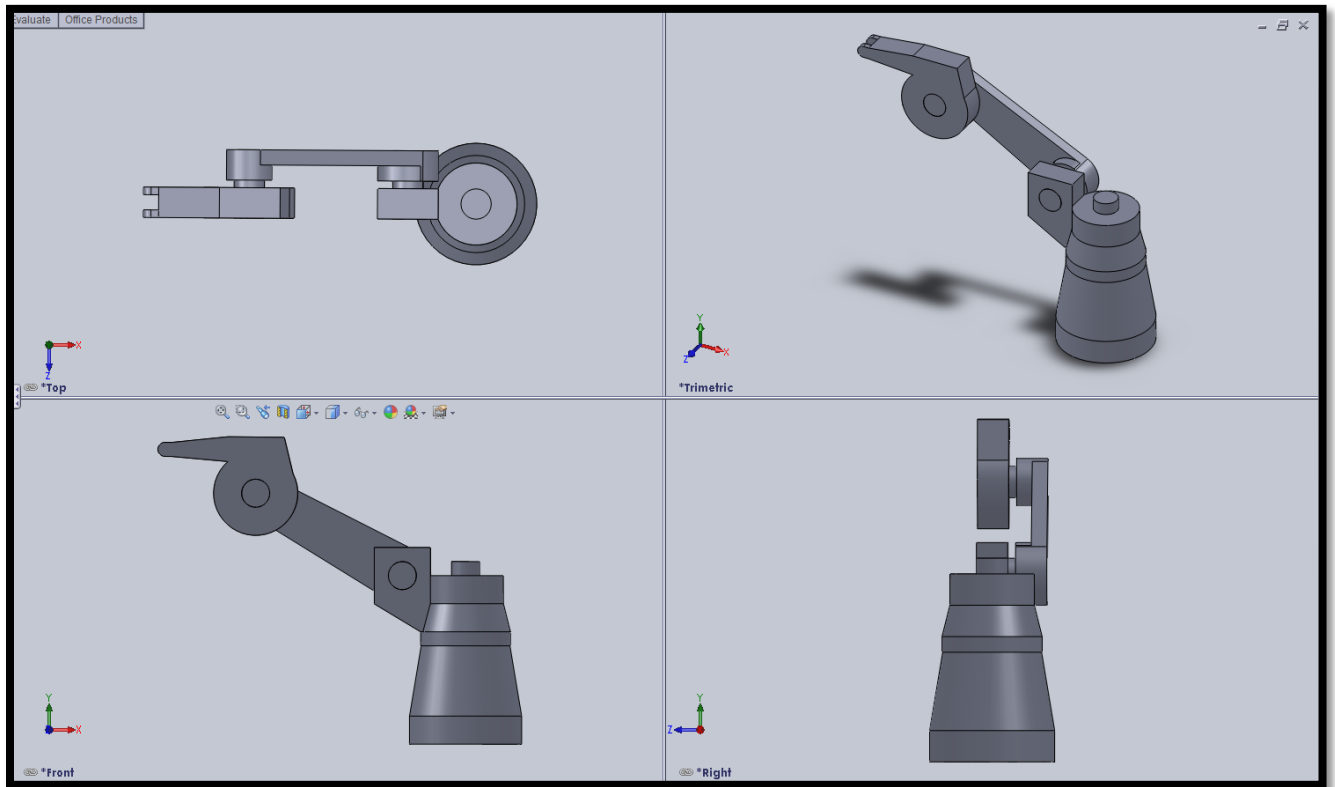

Figure 54- Robotic Arm Design

3.3.2 Nozzle

The nozzle is found on the tip of the arm. The tip will have an opening that acts as a suction piece. This piece picks up any debris or non-viable tissue found on a burn wound. Inside the nozzle are two parallel tubes running downward beside the vacuum space. The tubes are filled with saline to prep and cleanse the burn wound for the procedure. At the end of the tube is a ridge that acts a sprinkler and directs the flow of the fluid into the vacuum space. The vacuum has a weak suction power that debrides the wound in multiple waves, creating a painless debridement procedure. The debris is collected in a bin attached to the ball screw railing beside the power source. The following series of figures, **Figure 56, 57,** and **58** show the nozzle layout.

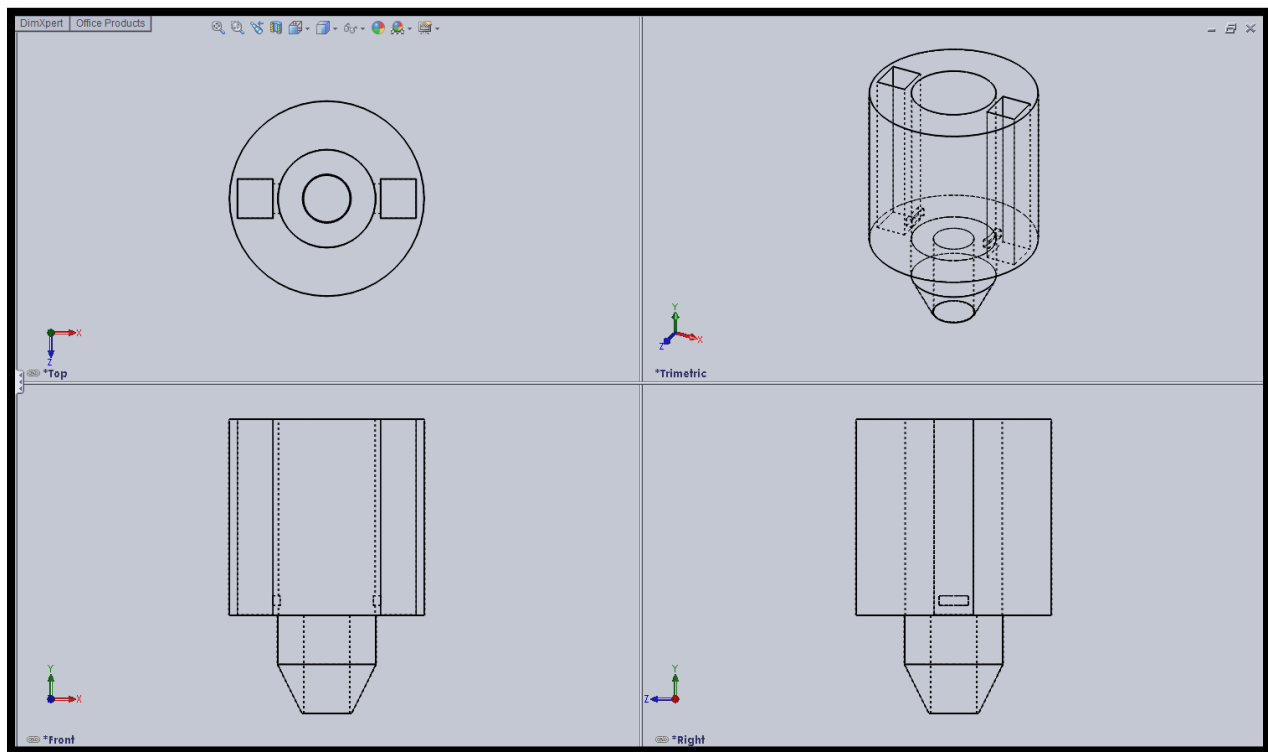

Figure 56- Nozzle Design –Wire View

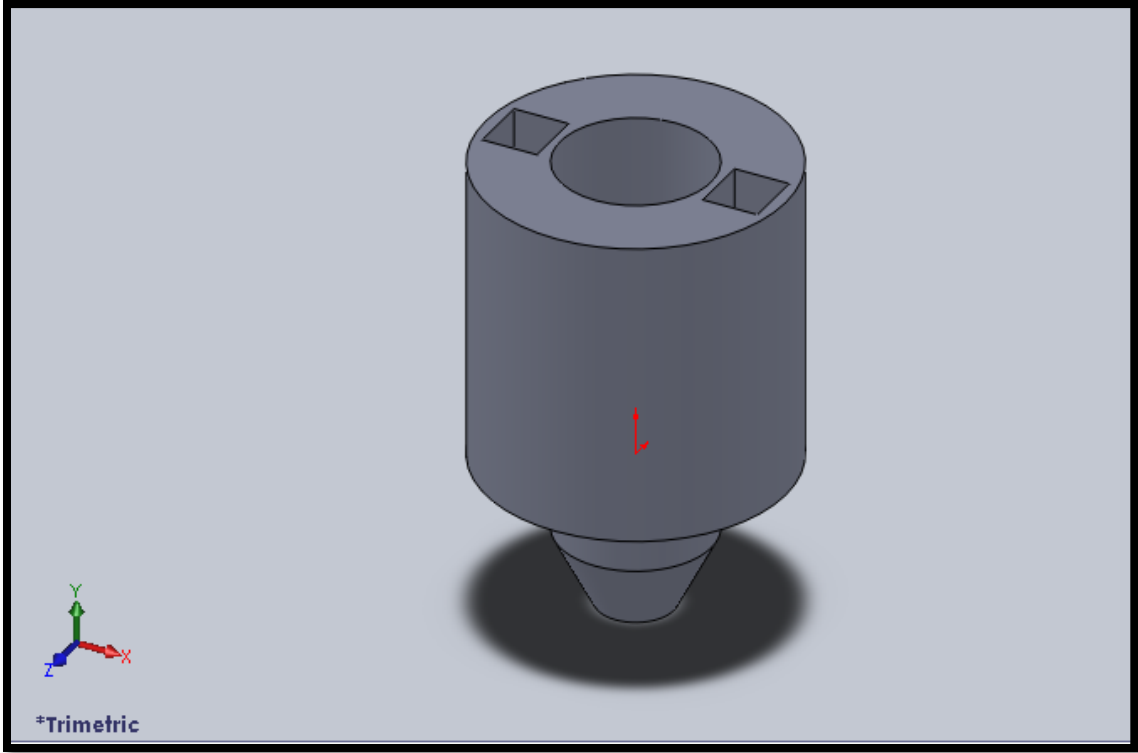

Figure 57- Nozzle Design

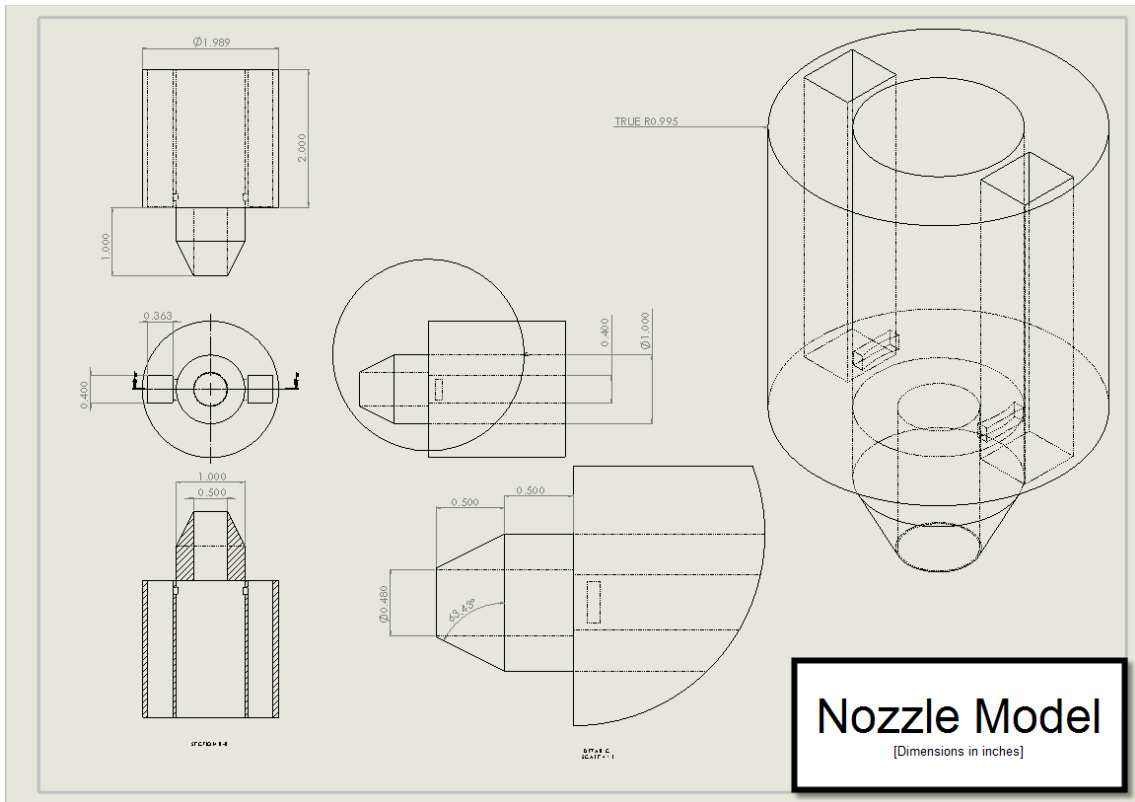

Figure 58- Engineering Drawing of Nozzle

3.3.3 Benefits

These are some conventional methods used to debride non-viable tissue. However most techniques are either flawed or could be improved upon. Below are previously mentioned debridement techniques that are commonly used.

- Sharp debridement is the most commonly used approach to debriding burn wounds. This technique uses sterile knives and scalpels.
- Autolytic debridement is when the body uses its own enzymes to rehydrate and moisturize, soften, and eventually liquefy hard dead tissue. The process is slow and prone to developing invasive infection, malnourishment and severe pain.
- Enzymatic debridement utilizes chemical enzymes. These enzymes are fast acting products that produce nonviable tissue. It can be effective in patients with minimal necrotic wounds but is time consuming and labor intensive.
- Mechanical debridement uses the wet to dry technique. This method involves a moist dressing that is applied and peeled off when dry; this is done to remove debris and slough tissue. It is a painful and non-specific process.
- Laser debridement is an effective and precise method of removing dead tissue. However the technique comes with the risk of thermal damage to viable tissue.
- Maggot therapy is when actual larva maggots are used to ingest and break down necrotic tissue. This ancient method is still surprisingly effective, but is rarely accepted among patients.

Our theoretical design should be a simple product that can be operated by a doctor with adequate training in the treatment of burn debridement. Through the use of a compute console system the idea of telesurgery becomes a possibility. The surgeon could perform the debridement

via computer station just a few feet away from the patient. To further this idea a surgeon could have the option of operating through a computer console miles away from the patient. With the help of robotic arms the fatigue doctors experience during these types surgeries would drastically decrease. During intensive surgeries, doctors often experience hand tremors. The unsteady hands of a surgeon cannot compete with those of a surgical robot. These robotic arms would be programmed to ignore the sporadic tremors of the surgeon this would keep the arm steady.

Health care professional use the TIME concept to assess and treat burn or any wounds. The goal of this method is to restore healthy biochemical reactions that stimulate the healing process. Step one the Necrotic Tissue (**T**) and foreign bodies must be cleared from the wound. Step two Infection (**I**) must be controlled. Moisture (**M**) balance must be restored to prevent tissue from rotting. This will obviously prevent healing. The edge of the Epithelium (**E**) rising is a vital and final sign of the wound healing. The main priorities for the debridement product are to decrease the risk of infection, increase blood flow, and make the debridement process a relatively pain free procedure.

CHAPTER 4. CONCLUSION

In conclusion, with a better understanding of burns, the human skin structure, management of burns within hospitals and ambulances, and the recovery process, the project team has been able to determine an innovative way to remove necrotic skin from a burn patient. The design was created using a combination of current technology and main components including a robotic arm that can access any point on an x, y, z plane and a vacuum based suction nozzle used at the tip of the robotic arm to collect necrotic skin. The design was and should be built with the following key goals in mind:

- To provide an effective method of burn wound cleaning
- Automating the process of cleaning a burn wound
- Decreasing possibility of human error
- Decreasing the risk of an infection
- Decreasing pain level of the burn wound cleaning procedure
- Decreasing patient recovery period

We believe that the method is viable and feasible for the future, and would recommend further research and calculations for the design implementation such as power options, bill of materials, hardware and software. While expense may be a concern for this type of medical instrument, it is believed the future compensation will be a great investment.

GLOSSARY

The technical terms in this section are provided by MedicineNet.com

Chemoprophylaxis: The use of a chemical agent to prevent the development of a disease. See:

<http://www.emedicinehealth.com/script/main/art.asp?articlekey=26649>

Debridement: The act of debriding (removing dead, contaminated or adherent tissue or foreign material). Debridement encompasses enzymatic debridement (as with proteolysis enzymes), mechanical nonselective debridement (as in a whirlpool), and sharp debridement (by surgery).

<http://www.medterms.com/script/main/art.asp?articlekey=40483>

Dehydration: occurs when the amount of water leaving the body is greater than the amount being taken in. The body is very dynamic and always changing. This is especially true with water in the body. We lose water routinely when we:

- breathe and humidified air leaves the body;
- sweat to cool the body; and
- urinate or have a bowel movement to rid the body of waste products.

In a normal day, a person has to drink a significant amount of water to replace this routine loss.

If intravascular (within the blood vessels) water is lost, the body can compensate somewhat by shifting water from within the cells into the blood vessels, but this is a very short-term solution.

The body lives within a very narrow range of normal parameters, and signs and symptoms of dehydration will occur quickly if the water is not replenished.

The body is able to monitor the amount of fluid it needs to function. The thirst mechanism signals the body to drink water when the body is dry. As well, hormones like anti-diuretic hormone (ADH) work with the kidney to limit the amount of water lost in the urine when the body needs to conserve water.

<http://www.medicinenet.com/dehydration/article.htm>

Dermis: The lower or inner layer of the two main layers of cells that make up the skin. The dermis contains blood vessels, lymph vessels, hair follicles, and glands that produce sweat, which helps regulate body temperature, and sebum, an oily substance that helps keep the skin from drying out. Sweat and sebum reach the skin's surface through tiny openings in the skin that act as pores.

<http://www.medterms.com/script/main/art.asp?articlekey=2958>

Epidermis: The upper or outer layer of the two main layers of cells that make up the skin. The epidermis is mostly made up of flat, scale-like cells called squamous cells. Under the squamous cells are round cells called basal cells. The deepest part of the epidermis also contains melanocytes. These cells produce melanin, which gives the skin its color.

<http://www.medterms.com/script/main/art.asp?articlekey=3278>

Eschar: The scab formed when a wound or skin is sealed by the heat of cautery or burning. Also the dark crusted ulcer (tache noire) at the site of the chigger (mite larva) bite in scrub typhus.

<http://www.medterms.com/script/main/art.asp?articlekey=3313>

First Degree Burn: is superficial and causes local inflammation of the skin. Sunburns often are categorized as first degree burns. The inflammation is characterized by pain, redness, and a mild amount of swelling. The skin may be very tender to touch.

<http://www.medicinenet.com/burns/article.htm>

Hypodermis: (Subcutaneous tissue) Where larger blood vessels and nerves are located. This is the layer of tissue that is most important in temperature regulation.

<http://www.medicinenet.com/burns/article.htm>

Necrotic Tissue: Synonymous with dead. Necrotic tissue is dead tissue.

<http://www.emedicinehealth.com/script/main/art.asp?articlekey=4515>

Second Degree Burn: are deeper and in addition to the pain, redness and inflammation, there is also blistering of the skin.

<http://www.medicinenet.com/burns/article.htm>

The Rule of Nine: assesses the percentage of burn and is used to help guide treatment decisions including fluid resuscitation and becomes part of the guidelines to determine transfer to a burn unit.

You can estimate the body surface area on an adult that has been burned by using multiples of 9.

An adult who has been burned, the percent of the body involved can be calculated as follows:

Head = 9%

Chest (front) = 9%

Abdomen (front) = 9%

Upper/mid/low back and buttocks = 18%

Each arm = 9% (front = 4.5%, back = 4.5%)

Groin = 1%

Each leg = 18% total (front = 9%, back = 9%)

As an example, if both legs ($18\% \times 2 = 36\%$), the groin (1%) and the front chest and abdomen were burned, this would involve 55% of the body.

http://www.emedicinehealth.com/burn_percentage_in_adults_rule_of_nines/article_em.htm

Third Degree burn: are deeper still, involving all layers of the skin, in effect killing that area of skin. Because the nerves and blood vessels are damaged, third degree burns appear white and leathery and tend to be relatively painless.

Burns are not static and may mature. Over a few hours a first degree burn may involve deeper structures and become second degree. Think of a sunburn that blisters the next day. Similarly, second degree burns may evolve into third degree burns.

Regardless of the type of burn, inflammation and fluid accumulation in and around the wound occur. Moreover, it should be noted that the skin is the body's first defense against infection by microorganisms. A burn is also a break in the skin, and the risk of infection exists both at the site of the injury and potentially throughout the body.

Only the epidermis has the ability to regenerate itself. Burns that extend deeper may cause permanent injury and scarring and not allow the skin in that area to return to normal function.

<http://www.medicinenet.com/burns/article.htm>

Ventilator: A ventilator is a machine which mechanically assists patients in the exchange of oxygen and carbon dioxide (sometimes referred to as artificial respiration).

<http://www.medterms.com/script/main/art.asp?articlekey=5983>

Chemoprophylaxis: The use of a chemical agent to prevent the development of a disease. See:
<http://www.emedicinehealth.com/script/main/art.asp?articlekey=26649>

Necrotic Tissue: Synonymous with dead. Necrotic tissue is dead tissue.
<http://www.emedicinehealth.com/script/main/art.asp?articlekey=4515>

REFERENCES

1. "Debridement - Procedure, Blood, Removal, Pain, Time, Infection, Cells, Types, Risk, Definition, Purpose, Description, Diagnosis/Preparation, Aftercare, Risks, Normal Results, Alternatives." Encyclopedia of Surgery: A Guide for Patients and Caregivers. Web. 16 Oct. 2010. <<http://www.surgeryencyclopedia.com/Ce-Fi/Debridement.html>>.
2. "Skin, Skin Information, Facts, News, Photos -- National Geographic." Science and Space Facts, Science and Space, Human Body, Health, Earth, Human Disease - National Geographic. Web. 22 Mar. 2011. <<http://science.nationalgeographic.com/science/health-and-human-body/human-body/skin-article.html>>.
3. "Trauma Programs: ATLS." American College of Surgeons. Web. 22 Mar. 2011. <<http://www.facs.org/trauma/atls/index.html>>.
4. "Treatment of Mild Burns." Health Tips, Health News, Health Information. 13 Aug. 2010. Web. 08 Apr. 2011. <<http://asiancraftinc.com/2010/08/13/treatment-of-mild-burns/>>.
5. "Wound Debridement - Information, Symptoms and Treatment | Bupa UK." Private Health Insurance, Individual, Group, Family Healthcare | Bupa UK. Nov. 2009. Web. 14 Jan. 2011. <<http://www.bupa.co.uk/individuals/health-information/directory/w/wound-debridement>>.
6. "Debridement - Procedure, Blood, Removal, Pain, Time, Infection, Cells, Types, Risk, Definition, Purpose, Description, Diagnosis/Preparation, Aftercare, Risks, Normal Results, Alternatives." Encyclopedia of Surgery: A Guide for Patients and Caregivers. Web. 16 Oct. 2010. <<http://www.surgeryencyclopedia.com/Ce-Fi/Debridement.html>>.
7. "Educating the Burn Care Professionals." Web. 22 Mar. 2011. <<http://www.burnsurgery.com/>>.
8. "Emergency Care For Burn Victims." Web. 22 Mar. 2011. <<http://uuhs.utah.edu/burncenter/emergencycare/index.html>>.
9. American Burn Association. Web. 22 Mar. 2011. <<http://www.ameriburn.org>>.
10. American Burn Association. "National Burn Repository. Rep. Ameriburn, 2009." Web. 22 Mar. 2011. <<http://www.ameriburn.org/2009NBRAnnualReport.pdf>>.
11. Americare Medical. "Americare Medical - Home Infusion Therapy." Americare Medical - Medical Staffing, Home Medical Supplies and Home Medical Care in Michigan. 2007. Web. 08 Apr. 2011. <<http://www.americaremedical.com/rxiv.htm>>.
12. Anu Singhai, Emane Reis, Morris Kerstein "Options for Nonsurgical Debridement of Necrotic Wounds" Volume 14, 2001 <<http://endoflifecare.tripod.com/imbeddedlinks/id3.html> >
13. Atlan M., Gross M., Vitalis T., Rancillac A., Rossier J., Boccara A. " High-speed wave-mixing laser Doppler imaging, in vivo.", March 2008 <<http://hal.archivesouvertes.fr/docs/00/26/16/50/PDF/FFTspectroMice.pdf>>
14. Aung, Barbara J. "Aung Foot Health Clinics." Aung Foot Health Clinics | Tucson Podiatry | Tucson Foot Doctor. 2008. Web. 08 Apr. 2011. <http://healthy-feet.com/wc_6.html>.
15. Australian Government Department of Health and Ageing and Royal Australian College of Surgeons, "Prioritizing Summary Low frequency ultrasound debridement ", Horizon Scanning Technology, 2007

16. Bioskinrevival. "Burn Wound Healing." Web. 22 Mar. 2011.
<<http://www.bioskinrevival.com/burnwoundhealing/>>.
17. Boyd J., "High-Pressure Pulsatile Lavage Causes Soft Tissue Damage", *Clinical Orthopaedics and Related Research*, 2004, 427, 13-17.
18. Boyd JI, "High-Pressure Pulsatile Lavage Causes Soft Tissue Damage", *Clinical Orthopaedics and Related Research*, 2004, 427, 13-17.
19. Breuing K., "Early Experience Using Low-Frequency Ultrasounds in Chronic Wounds", *Annals of Plastic Surgery*, Volume 55, Number 2, 2005
20. Breuing, Karl H. "Early Experience Using Low Frequency Ultrasound in Chronic Wounds." *Annals of Plastic Surgery* 55.2 (2005). [Http://wundbehandlung.net/](http://wundbehandlung.net/). Aug. 2005. Web. 14 Apr. 2011.
<http://wundbehandlung.net/opencms/opencms/wundbehandlung/dokumente/Early_Experience_Using_Low-Frequency_Ultrasound_in_Chronic_Wounds.pdf>.
21. Burnsurgery.org. "Use of Skin Substitutes." Burnsurgery.org. 2005. Web. 8 Apr. 2011.
<http://www.burnsurgery.org/Modules/BurnWound%201/sect_VIII.htm>.
22. Chipp E., Warner R., McGill D., Moiemmen N. "Air Ambulance Transfer of Adult Patients to a UK Regional Burns Centre: Who Needs to Fly?" *Science Direct*. Dec. 2010. Web. 20 Mar. 2011. <<http://www.ncbi.nlm.nih.gov/pubmed/20708337>>.
23. Cubison C. , "Dermal preservation using the VERSAJET[®] Hydrosurgery System for debridement of pediatric burns", *Burns*, 2006, 32, 714-720.
24. Cubison CS et al, "Dermal preservation using the VERSAJET[®] Hydrosurgery System for debridement of pediatric burns", *Burns*, 2006, 32, 714-720.
25. Devgan L, "Modalities for the Assessment of Burn Wound Depth", *Journal of Burns and Wounds*, Volume 5, 2006
26. Devgan L., Bhat S., Aylwar S., R. Spence R. "Modalities for the Assessment of Burn Wound Depth", *Journal of Burns and Wounds*, Volume 5, February 2006
27. Enoch S., "Emergency and Early Management of burns and scalds", *British Medical Journal*, Volume 338, 2009
28. Enviro Safety Product. Advertisement." EnviroSafety Products - 3M Respirators, Peltor Hearing Protection, Safety Vests on Sale. "Web. 08 Apr. 2011.
<<http://www.envirosafetyproducts.com/emt-scissors.html>>.
29. Granick M. , "Efficacy and cost-effectiveness of a high-powered parallel waterjet for wound debridement", *Wound Repair & Regeneration*, 2006, 14, 394-397.
30. Granick M., "Efficacy and cost-effectiveness of a high-powered parallel waterjet for wound debridement", *Wound Repair & Regeneration*, 2006, 14, 394-397.
31. Granick M., "Toward a common language; surgical wound bed preparation and debridement", *Wound Repair & Regeneration*, 2006, 14, S1-S10.
32. Granick MS, " Toward a common language; surgical wound bed preparation and debridement", *Wound Repair & Regeneration*, 2006, 14, S1-S10.
33. Herndon D. "Total Burn Care." Edinburgh: Saunders Elsevier, 2007. Print.
34. Johnson M., Reg R.. "Partial-thickness Burns: Identification and Management | Advances in Skin & Wound Care | Find Articles at BNET." Find Articles at BNET | News Articles, Magazine Back Issues & Reference Articles on All Topics. July-Aug. 2003. Web. 08 Apr. 2011.
<http://findarticles.com/p/articles/mi_qa3977/is_200307/ai_n9270135/>

35. Johnson, R. M., Richard R. "Partial-thickness Burns: Identification and Management | Advances in Skin & Wound Care | Find Articles at BNET." Find Articles at BNET | News Articles, Magazine Back Issues & Reference Articles on All Topics. Summer 2003.
36. Klein M., " The VERSAJET[®] Water Dissector: A new tool for tangential excision", Journal of Burn Care & Rehabilitation 2005, 26, 483-487.
37. Klein MB, "The VERSAJET[®] Water Dissector: A new tool for tangential excision", Journal of Burn Care & Rehabilitation 2005, 26, 483-487.
38. Kosta Y., Mumcuoglu "Maggot De'bridement Therapy in Outpatients"
39. Lara Devgan. *Modalities for the Assesment of Burn Wound Depth*. Rep. Journals of Burns and Wounds, 15 Feb. 2006. Web. 14 Apr. 2011. <<http://www.eplasty.com/pdf/volume05/jobw05e02.pdf>>.
40. Latenser B., "Critical care of the burn patient: The first 48 hours", Critical Care Medicine, Volume 37, Number 10, 2009
41. Magrath, J. A., R. A. Eady, and F. M. Pope. "Anatomy and Organization of Human Skin." Editorial. Black Well Publishing. Black Well Publishing. Web. 22 Mar. 2011. <http://www.blackwellpublishing.com/content/BPL_Images/Content_store/Sample_chapter/0632064293/DermChap3.pdf>.
42. Mastronicol, D., M. Romanelli, and P. Barachin. "Burn Depth Assessment Using a Tri-stimulus Colorimeter." WOUNDS. Apr. 2008. Web. 07 Apr. 2011. <<http://www.woundsresearch.com/article/4667>>.
43. Mayo Clinic. "Burns: First Aid - MayoClinic.com." 5 Jan. 2010. Mayo Clinic. Web. 08 Apr. 2011. <<http://www.mayoclinic.com/health/first-aid-burns/FA00022>>.
44. McAlee J., "A Prospective Randomized Study Evaluating the Time Efficiency of the VERSAJET[®] Hydrosurgery System and Traditional Wound Debridement", 2005, Presented at ACFAS Conference. Data on File.
45. McCardle J., "VERSAJET[®] hydroscalpel: treatment of diabetic foot ulceration", British Journal of Nursing, 2006, 15, Tissue Viability Supplement.
46. McCardle JE, "VERSAJET[®] hydroscalpel: treatment of diabetic foot ulceration", British Journal of Nursing, 2006, 15
47. MedicineNet. "Chemoprophylaxis Definition - Medical Dictionary Definitions of Popular Medical Terms Easily Defined on MedTerms." MedicineNet. 3 Feb. 2004. Web. 08 Apr. 2011. <<http://www.medterms.com/script/main/art.asp?articlekey=26649>>.
48. MedicineNet. *MedicineNet - Health and Medical Information Produced by Doctors*. 2011. Web. 14 Apr. 2011. <<http://www.medicinenet.com/script/main/hp.asp>>.
49. Morgan E. "Ambulatory Management of Burns - November 1, 2000 - American Family Physician." Home Page -- American Academy of Family Physicians. American Family Association, 1 Nov. 2001. Web. 22 Mar. 2011. <<http://www.aafp.org/afp/20001101/2015.html>>.
50. Morgan E., Scott B., Barker J. "Ambulatory Management of Burns - November 1, 2000 - American Family Physician." Home Page -- American Academy of Family Physicians. 1 Nov. 2000. Web. 08 Apr. 2011. <<http://www.aafp.org/afp/20001101/2015.html>>.
51. Mosti G, "The Debridement of Chronic Leg Ulcers by Means of a New, Fluidjet - Based Device", Wounds, 2006, 18, 227-237.
52. Mosti G., "The Debridement of Chronic Leg Ulcers by Means of a New, Fluidjet - Based Device", Wounds, 2006, 18, 227-237.

53. Mulholland M., Doherty G. "Complications in Surgery". Philadelphia: Wolters Kluwer/Lippincott Williams & Wilkins Health, 2011. Print.
54. National Cancer Institute. Web. 8 Apr. 2011. <<http://www.cancer.gov/>>.
55. Paolo D., "The use of VERSAJET[®] in the limb salvage following failure of minor amputation in diabetic foot", 2005, AIUC Meeting. Data on File.
56. Pape S., Skouras C., Byrne P. "An Audit of the Use of Laser Doppler Imaging (LDI) in the Assessment of Burns of Intermediate Depth." *Burns Journal*. July 2000. Web. <[http://www.burnsjournal.com/article/S0305-4179\(00\)00118-2/abstract](http://www.burnsjournal.com/article/S0305-4179(00)00118-2/abstract)>.
57. Rennekampff H., "Debridement of burn wounds with a water jet surgical tool", *Burns*, 2006, 32, 64-69.
58. Rennekampff H., "Debridement of burn wounds with a water jet surgical tool", *Burns*, 2006, 32, 64-69.
59. Robodoc. "ROBODOC® - a CUREXO Technology Company." ROBODOC. 2008. Web. 08 Apr. 2011. <<http://www.robodoc.com/home.html>>.
60. Sherman, Ronald, "Debridement - Procedure, Blood, Removal, Pain, Time, Infection, Cells, Types, Risk, Definition, Purpose, Description, Diagnosis/Preparation, Aftercare, Risks, Normal Results, Alternatives.", *Encyclopedia of Surgery: A Guide for Patients and Caregivers*. Apr. 2006. Web. 2 Feb. 2011. <<http://www.surgeryencyclopedia.com/Ce-Fi/Debridement.html>>.
61. Sherman, Ronald, "Debridement - Procedure, Blood, Removal, Pain, Time, Infection, Cells, Types, Risk, Definition, Purpose, Description, Diagnosis/Preparation, Aftercare, Risks, Normal Results, Alternatives.", *Encyclopedia of Surgery: A Guide for Patients and Caregivers*. Apr. 2006. Web. 2 Feb. 2011. <<http://www.surgeryencyclopedia.com/Ce-Fi/Debridement.html>>.
62. Silver Sulfadiazine Cream. Advertisement. Medical Supplies | Medical Equipment | Hospital Medical Supplies | Hospital Equipment. Mountainside Medical Equipment. Web. 08 Apr. 2011. <<http://www.mountainside-medical.com/products/Silver-Sulfadiazine-Cream.html>>.
63. Singhal A, "Wound Care: Nonsurgical Options.", *Huntington's Disease Support Information*. Mar. 2001. Web. 21 Dec. 2010. <<http://endoflifecare.tripod.com/imbeddedlinks/id3.html>>.
64. Smith J., "Minimal bacterial transfer during and following hydrosurgical debridement.", poster presented at SAWC Florida 2010
65. SurgeryEncyclopedia. "Debridement." *Encyclopedia of Surgery: A Guide for Patients and Caregivers*. SurgeryEncyclopedia, 2011. Web. 14 Apr. 2011. <<http://www.surgeryencyclopedia.com/Ce-Fi/Debridement.html>>.
66. Suzuki K, "Low-Frequency Ultrasound Therapy of Lower Extremity Wounds Significantly Increases the Peri-Wound Skin Perfusion Pressure", Presented at the Diabetic Foot Global Conference 2009, Los Angeles, CA
67. Suzuki K., Cowan L., Aronowitz J., "Low-Frequency Ultrasound Therapy of Lower Extremity Wounds Significantly Increases the Peri-Wound Skin Perfusion Pressure", Tower Wound Care Center, Cedar-Sinai Medical Towers, Keck School OF medicine, University of Southern California, Los Angeles, CA
68. Suzuki, Kazu. *Low Frequency Ultrasound Therapy of Lower Extremity Wounds Significantly Increases the Peri-wound Skin Perfusion Pressure*. CEDARS-SINAI, 2009.

- Web. 14 Apr. 2001.
<<http://www.vasamed.com/documents/SuzukiDFcon09ArobellaStudyPoster.pdf>>.
69. Trauma J.,Sevitt S. "A Review of the Complications of Burns, Their Origin and Importance for Illness and Death." PubMed. 19 May 1979. Web. 08 Apr. 2011.
<<http://www.ncbi.nlm.nih.gov/pubmed/448773>>.
70. Wrong Diagnosis. "Complications of Burns - WrongDiagnosis.com." 26 Jan. 2011. Web. 08 Apr. 2011. <<http://www.wrongdiagnosis.com/b/burns/complic.htm>>.
71. Vitalis T., Atlan M., Rancillac A., Rossier J., "High-speed wave-mixing laser Doppler imaging, in vivo." March 2008, <<http://hal.archives-ouvertes.fr/docs/00/26/16/50/PDF/FFTspectroMice.pdf> >
¹Haas Automation. <http://www.haascnc.com/solutions_tooling.asp>
72. Brown University Department of Biomedicine "Robotic Surgery Da Vinci Surgical System Overview"
<http://biomed.brown.edu/Courses/BI108/BI108_2005_Groups/04/davinci.html>.
73. Intuitive Surgical Instruments. "EndoWrist Instruments"
<<http://www.intuitivesurgical.com/products/instruments/>>
74. "HowStuffWorks "How Robotic Surgery Will Work"" *HowStuffWorks - Learn How Everything Works!* Web. 1 Apr. 2011. <<http://www.howstuffworks.com/robotic-surgery.htm>>.

APPENDICES

Engineering Photos and Drawings

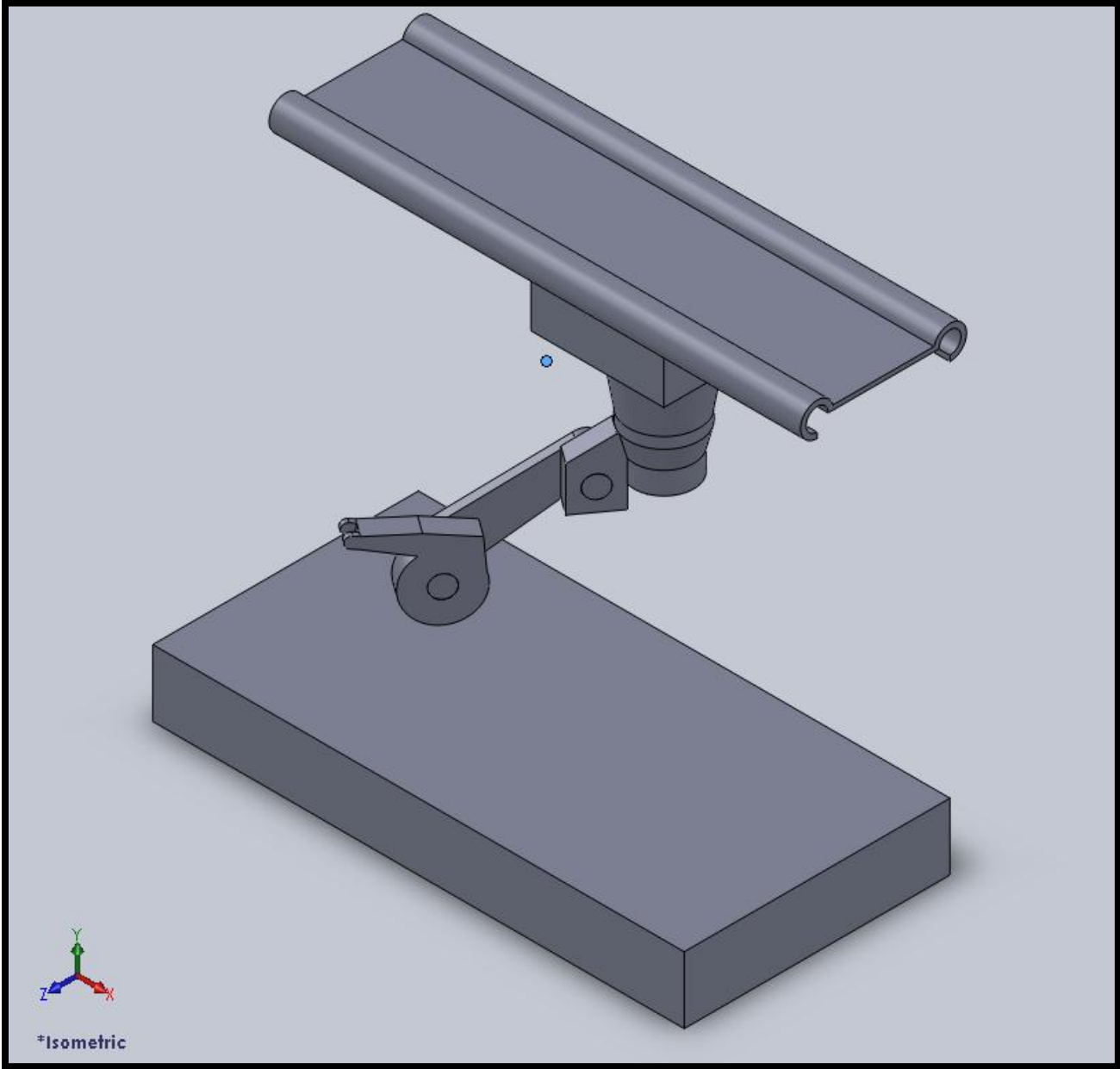

Figure 59- Mock Assembly of Final Project

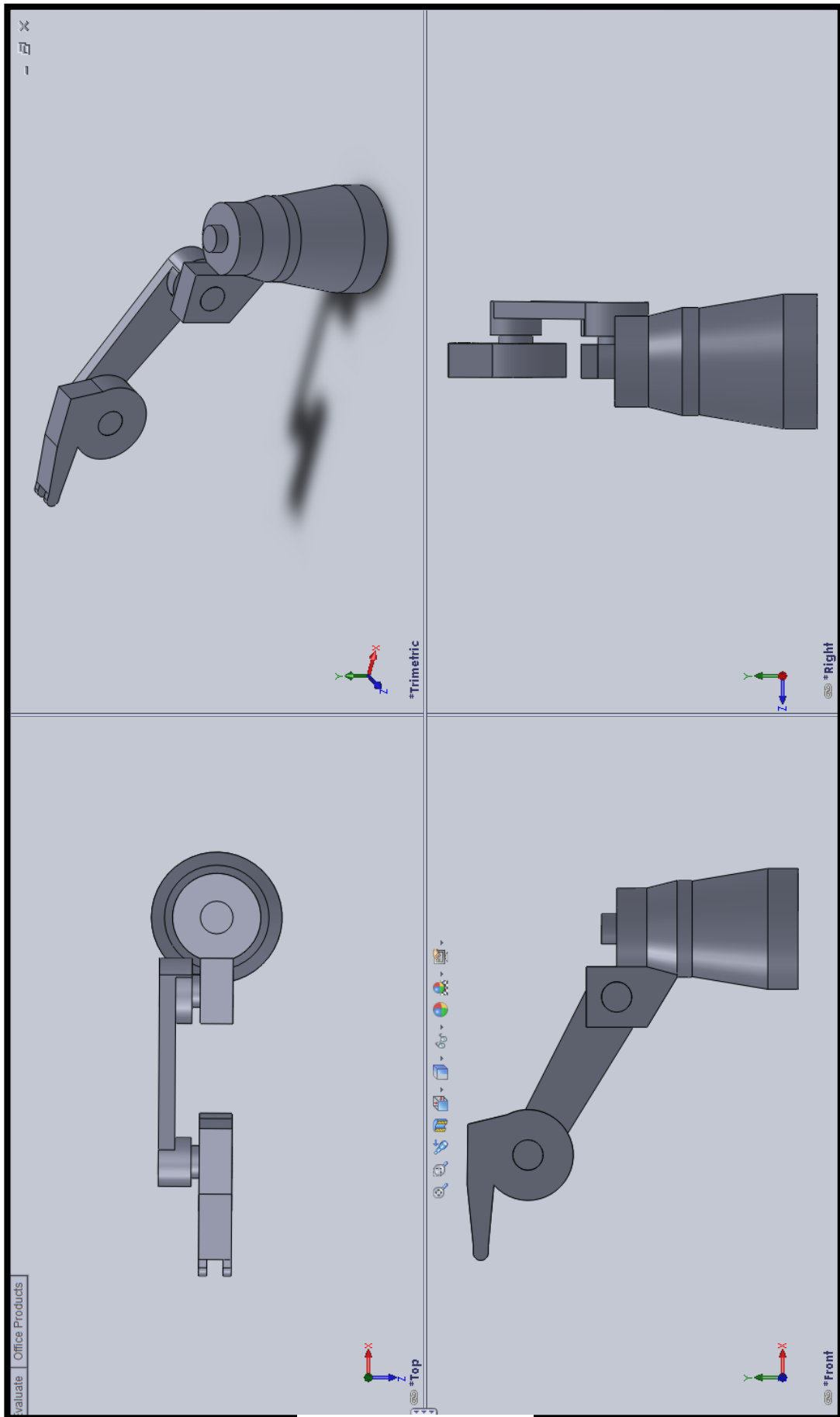

Figure 60 - Robotic Arm

Robotic Arm Model

[Dimensions in inches]

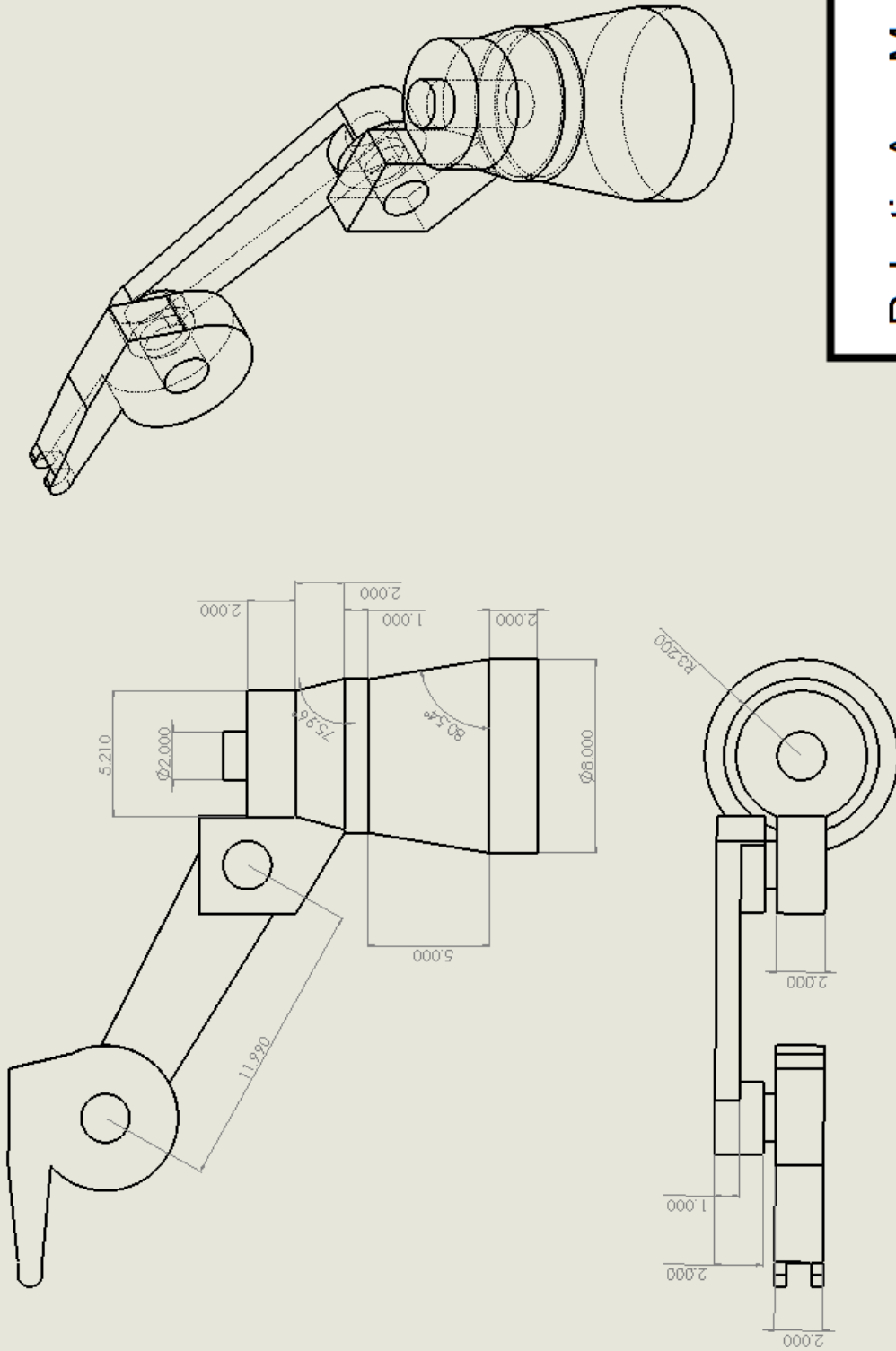

Figure 61- Engineering Drawing of Robotic Arm

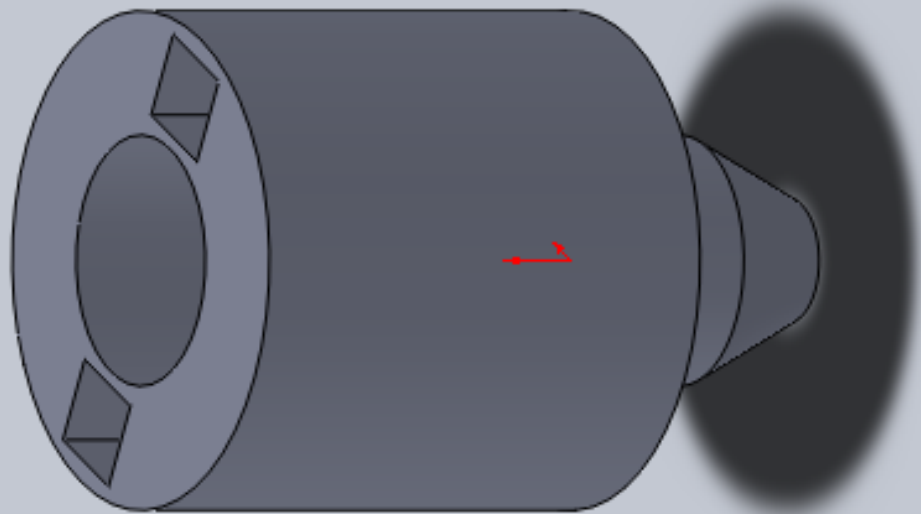

Figure 62- Nozzle Design



#Trimetric

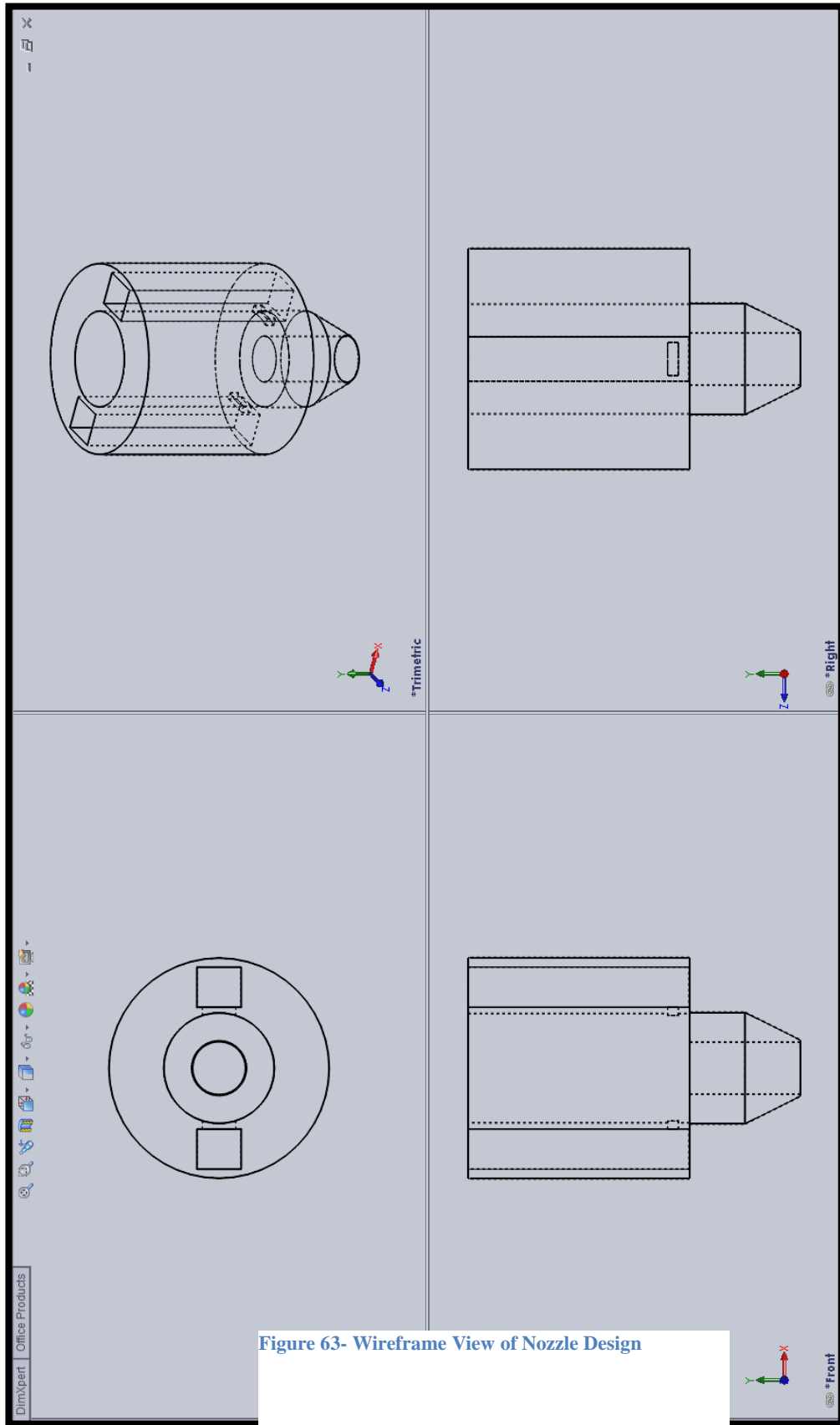
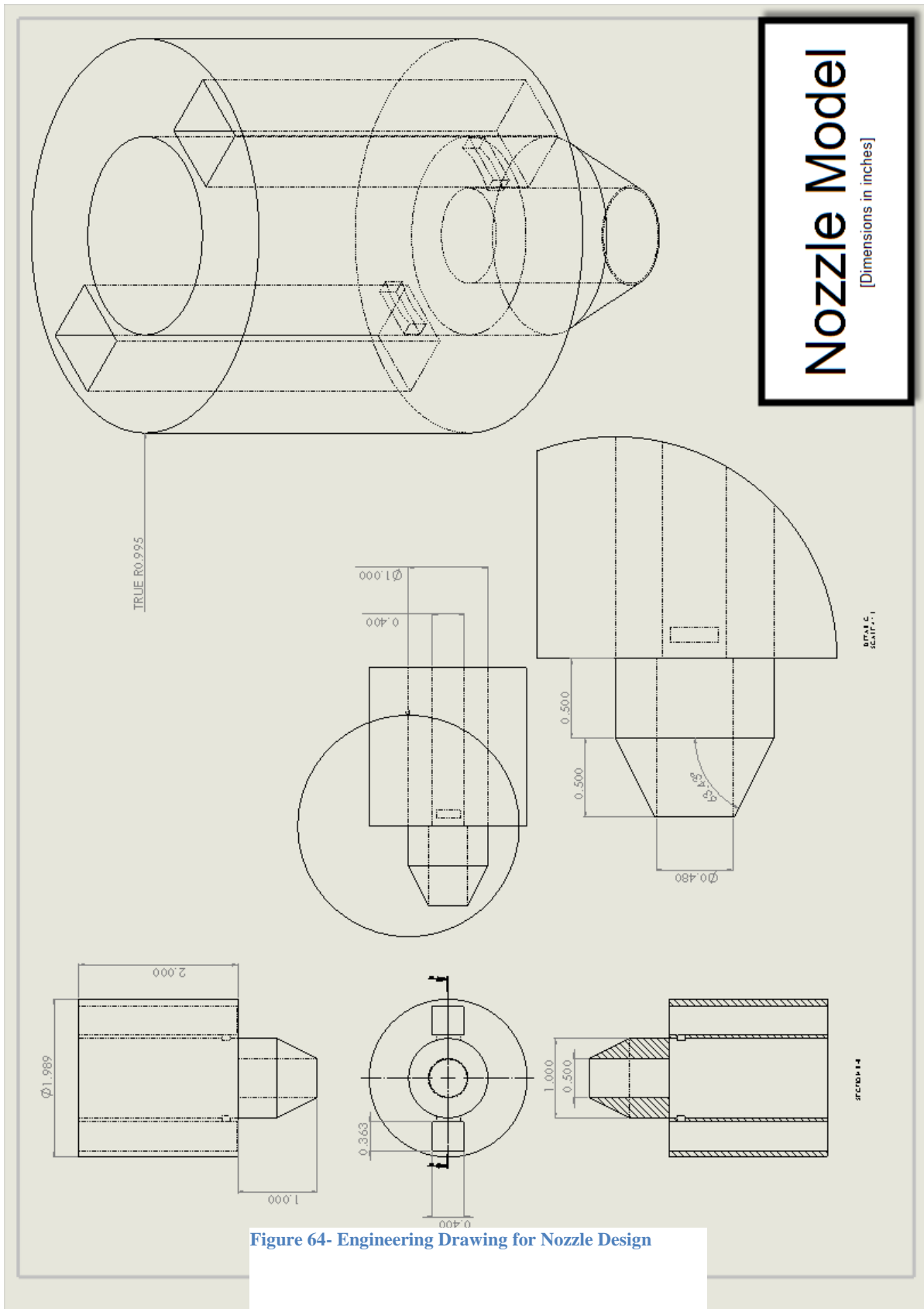

Figure 63- Wireframe View of Nozzle Design



Nozzle Model

[Dimensions in inches]

Figure 64- Engineering Drawing for Nozzle Design