

Capturing Tradition: Feasibility and Promotion of Hasi Mish i Thatë



Daniel Bloemker,
Scott Cazier,
Sienna Mayer,
Heather Selmer

Submitted to Worcester Polytechnic Institute



Capturing Tradition: The Feasibility and Promotion of Hasi Mish i Thatë

Tirana, Albania

An Interactive Qualifying Project
submitted to the Faculty of the
WORCESTER POLYTECHNIC INSTITUTE
in partial fulfillment of the requirements for the
Degree of Bachelor of Science

By: Daniel Bloemker, Scott Cazier, Sienna Mayer, and Heather Selmer

December 17, 2015

Report Submitted to:
Rural Association Support Programme (RASP)



Advised By:
Professor Robert Hersh and Professor Robert Dempksi

This report represents work of WPI undergraduate students submitted to the faculty as evidence of a degree requirement. WPI routinely publishes these reports on its web site without editorial or peer review. For more information about the projects program at WPI, see <http://www.wpi.edu/Academics/Projects>

Abstract

Living in one of the poorest counties, goat farmers in the rural Has region of northeastern Albania and the Rural Association Support Programme aim to encourage economic development through commercializing underutilized traditional products. Key informant interviews and process observations captured the regional tradition of dried goat meat, Hasi “Mish i Thatë.” Systematic documentation and process analysis compared to industry standards led to identification of areas for quality control, hygiene, and traceability improvements. Calculations indicate that Hasi “Mish i Thatë” can result in a 140% increase in profit per goat. Further examination of product development led to suggested methods of promotion and distribution necessary to attain certification and sustained commercial success.

Acknowledgments:

Our team would like to thank all individuals, organizations, and groups who contributed to the success of our project.

Special thanks to:

- Our advisors, Professor Robert Dempski and Robert Hersh for their continued support and patience when advising and for their professional feedback on our report.
- The Rural Association Support Programme (RASP) for sponsoring the project.
- Prof Assoc. Dr. Petrit Dobi, the Executive Director of RASP for his guidance and expertise. We would also like to thank him for coordinating and translating many meetings and interviews with both experts and farmers.
- Naim Pacara, the Local Coordinator in the Has region, for his help organizing our trips to speak with farmers and translating during interviews.
- Kastriot Dajçi, the Chair of the Hasi Goat Association, for allowing us to visit his farm twice to observe and document the slaughtering and drying process and for the hospitality shown to us by him and his family.
- Dr. Ilir Lloha from the Biotechnology Department at the Agricultural University of Tirana for sharing his expert knowledge of meat processing.
- Prof. Dr. Ilia Kristo from the Faculty of Economics at the University of Tirana and his MBA marketing class for their insight on marketing and distribution of products in Albania.
- All farmers who interviewed with us for answering all our questions and for their great hospitality.

Finally, we would like to thank WPI for providing us the opportunity to participate in this project and all others who assisted in the success of the project.

Executive Summary

Background

The World Bank estimates only 22% of Albanians benefit from remittances, however of the 153 goat farms surveyed in the Has district in the northeastern region of Albania, 100% receive remittances. (Garnier, 2015). A 2004 census indicated that 40% of the population in the region lived below the absolute poverty line (Nevila, 2014). The main agricultural activity of this rural area is goat husbandry.

Currently, certain goat products are underutilized. Our sponsor the Rural Association Support Program (RASP), identified commercializing dried goat meat as means to increase farmers' income. RASP's approach to encourage such innovation is to develop the value of local products and facilitate access to markets. To aid in the development of goat products, RASP helped create the Hasi Goat Association (HGA).

Fresh meat, cheese, and milk were initially selected as high interest opportunities. However, the traditional product of dried meat was more recently chosen as in initial foray for HGA's commercialization efforts due to the simplicity of its production. With RASP's help, the HGA intends on highlighting the traditions of this product so that dried goat meat can be sold in larger cities. Since approximately 6,000 Hasi goats are raised in Has, promoting Hasi dried goat meat has the potential to help 178 goat farms in the region.

Objectives and Corresponding Methods

Three main objectives were developed to utilize the traditional product of dried goat meat to create a desirable, marketable product to increase economic opportunity in Has. Since traditional, mountain products are desirable to Albanian consumers, interviews and production analysis focused on preserving tradition while improving quality.

Determining the traditional practices of drying goat meat in the Has region through key informant interviews and observations was the first step towards understanding the drying process. The villages visited, marked in red in Figure 1, corresponded to villages of Has with the highest population of goats. These villages were selected since they would best represent goat rearing tendencies in the region.

Documenting current methods established the context needed to analyze potential improvements. A comparison between observations and safety criteria developed using published FAO standards, industry guidelines, and an interview with an Albanian food processing expert led to recommendations for good code of practice.

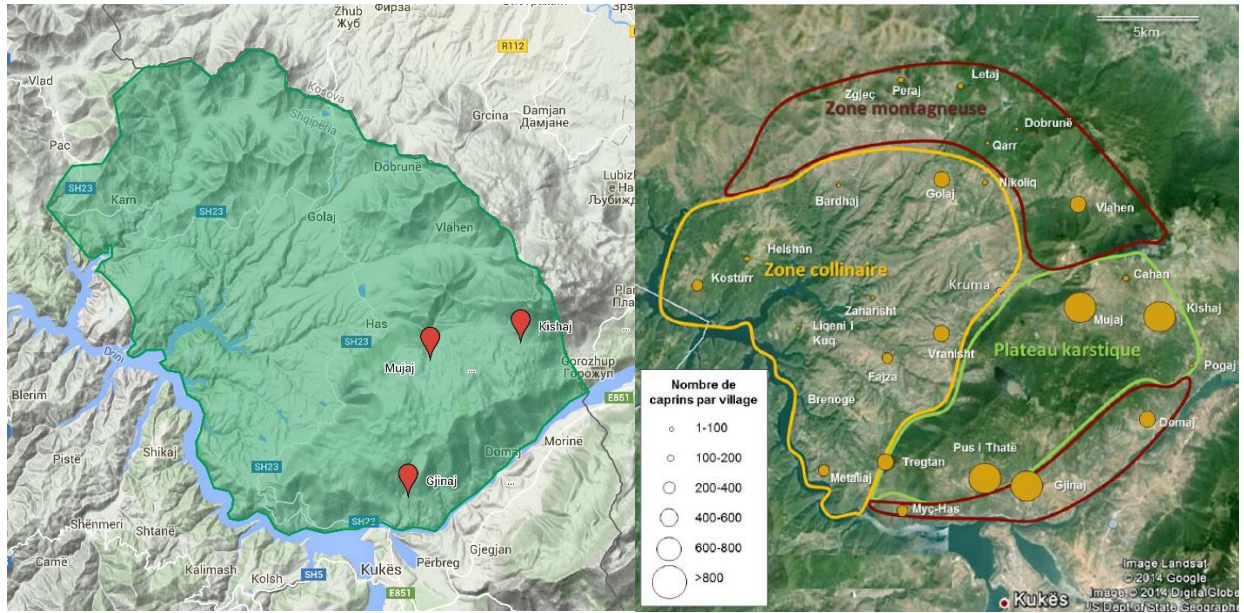

Figure 1: Villages interviewed (left) and corresponding goat densities (right)

The team focused on developing the Hasi goat brand and recommending a promotion plan for dried goat meat once the process had been improved to make dried meat more appealing to consumers. Using the compiled data from interviews, observations, standards, and production the team conducted a SWOT analysis to identify potential strategies for product development and marketing. Recommendations for developing the Hasi goat brand were provided to RASP and HGA.

Findings

Interviews and observations with eight farms from three villages across Has demonstrated the drying process throughout the region was consistent. Mid-December, once the first snow has fallen, begins the traditional time to dry goat meat. Farmers stated that colder winter air was a primary factor in preventing smaller pests and microorganisms from contaminating the meat. Farmers expressed that the current drying process is simple and the team only found small variations between villages. However, the major practices of salting and drying were uniform amongst all villages.

In each village slices of meat are cut approximately 50 cm long and 2-3 cm wide then layered in a dish with salt for 3-5 days. Strips of meat are then hung for 2-5 days, flipped, and dried for 2-5 more days; this range in drying time is due to external variables such as the weather. To ensure the meat is completely dry, farmers twist a portion with the intention of checking if the meat will break, if it breaks they know the meat is done drying. Every farmer called the final product “Mish i Thatë” and used it for familial

consumption throughout the winter. This traditional methods of drying meat has been passed down for generations, making Hasi "Mish i Thatë" a traditional product deeply rooted in the culture in Has.

Although this process is consistent throughout the region, few health and safety checks were observed. During the slaughtering process hygienic practices of frequent hand, tool, and surface washing were observed, but aside from these actions there were no apparent safety standards. Discussions with farmers revealed that the majority of the drying process is uncodified and measurements are never used. Analysis of interviews indicated that while farmers are experts in drying meat, lack of measurements prohibits their ability to provide precise production figures. Because of this, improving product safety and quality was identified as a major area of improving the final product while maintaining traditional practices.

Farmer’s interest in selling this traditional product already exists. The team found that farmers had already put thought into a potential distribution chain. Since families in Has produce their own dried meat, larger cities and traditional restaurants were identified as areas of interest for selling. The distribution network as explained by farmers in addition to potential network expansion as identified by the team was mapped out, as seen in Figure 2.

Farmers requested a minimum price of 2,000 L/kg for dried goat meat, but even 3,000 L/kg would be competitive given an existing price of 4,500 L/kg for dried beef in the area. Currently, farmers are able to make 15,000L selling goats in market. If they were to instead dry the meat and sell it at 3,000 L/kg an income of 36,000L per goat would be possible. Per goat that would result in an increased income of 21,000L. Using the average of 4 old goats being sold or dried yearly, a minimum potential added income of 83,680L per farm is possible by selling Hasi "Mish i Thatë." A summary of the potential yearly profit can be seen in Table 1.

Table 1: Potential yearly profit

Profits of Hasi “Mish i Thatë” for Farms Interviewed with Goat Husbandry as Primary Activity (Lek)	
Average Flock Size	116
Average Old Goats per Farm	14
Potential Profit per Goats as Hasi “Mish i Thatë”	21,000
Average Potential Profit of Large Goat Farm	288,400

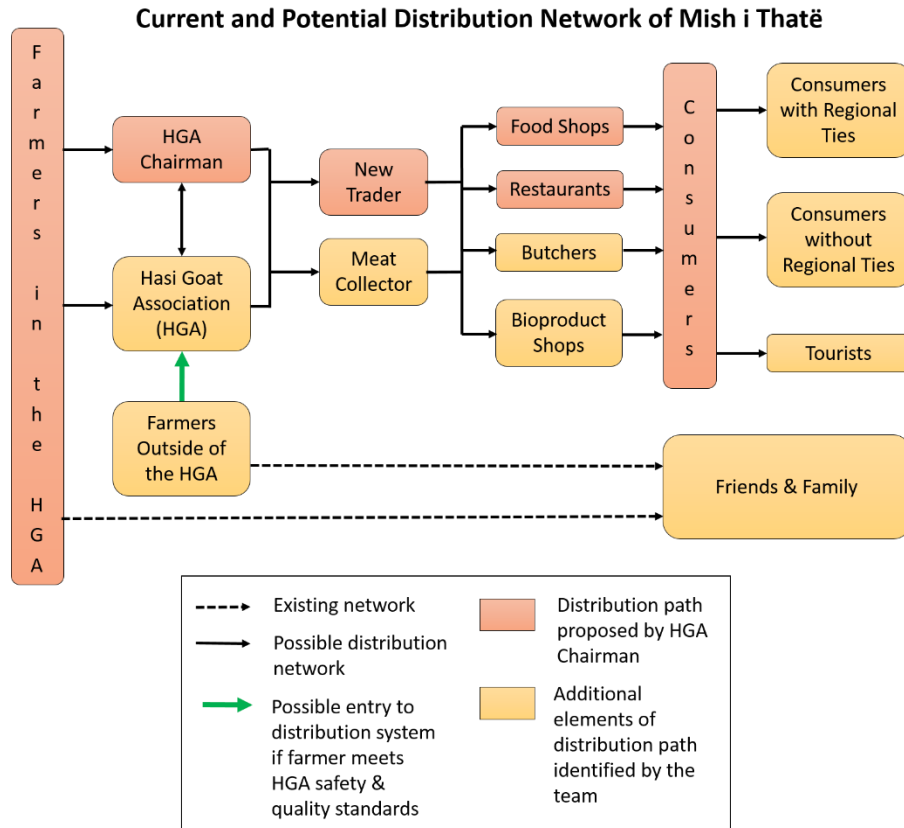

Figure 2: Current, proposed, and potential distribution network

After documenting this traditional practice and identifying areas of improvement, four key steps towards increasing product promotion and creating a Hasi goat brand development were identified:

1. Improve technical aspects to increase standardization and quality control.
2. Build capacity of farmers to improve the drying process and safety.
3. Develop a promotional campaign.
4. Establish a business plan.

This initial focus on improving technical aspects and increasing standardization of the drying process builds capacity for the brand and facilitates the ability of the product to receive the quality mark from HGA. This mark is intended to show the goat products are of a high quality and traditional origin, the intent is to use the HGA mark on all future Hasi goat products. Incorporating the quality mark creates more effective labeling and packaging, leading into the brand's overall promotional campaign. After increasing the product's quality and developing key factors of brand promotion, a business plan expanding upon the currently identified distribution network should be established so that clear steps leading to the commercial market can be taken.

Conclusions

Initial steps towards improving and distributing the traditional product of Hasi "Mish i Thatë" have been identified. Documenting current practice evolved to include recommendations for improving product safety. Highlighting the consistent tradition and high quality of Hasi "Mish i Thatë", RASP can prepare the product for commercialization. Analysis led to suggestions for a development plan to provide RASP with the materials and network necessary for successful distribution. Production and cost calculations suggest that with the correct changes Hasi "Mish i Thatë" can become a profitable commercial product for farmers.

Recommendations

The following list recommendations can be used to improve product quality and brand development:

Safety & Traceability	Quality Improvements	Brand Development
<ul style="list-style-type: none">• Document animal health care• Conduct ante-mortem and postmortem inspections• Proper waste disposal• Document animal sales• Separate area for drying• Pre-slaughter checklist• Codify sanitation	<ul style="list-style-type: none">• Consumer preference study• Flavoring experimentation• Decrease hanging time• Improve slice size, fat content, and salt content• Develop HGA code of practice (CoP)	<ul style="list-style-type: none">• Conduct market survey• Establish HGA logo as a quality mark• Develop consistent branding• Develop promotional materials• Brochure for consumers• Introduce smaller farms to supply chain

Authorship:

	Primary Author(s)	Primary Editor(s)
Title Page	Heather, Scott	-
Abstract	Scott, Sienna	Scott, Sienna
Acknowledgements	Heather	Daniel
Authorship	Sienna	All
Executive Summary	Daniel, Scott, Sienna	Sienna
Introduction	Sienna	Scott
Background	All	All
Methodology	Scott, Sienna	Scott, Daniel
Results	All	All
Conclusions	Heather	Sienna
Recommendations	Daniel	Heather, Scott
Appendices	All	Sienna
Original Photos	All	-
Original Diagrams	Daniel, Scott, Sienna	-

Table of Contents

Abstract.....	ii
Acknowledgments:	iii
Executive Summary.....	iv
Background	iv
Objectives and Corresponding Methods	iv
Findings	v
Conclusions	viii
Recommendations	viii
Authorship:	ix
List of Figures	xiii
List of Tables	xiv
Chapter 1: Introduction	1
Chapter 2: Background	3
2.1 Farming in the Has Region	3
2.1.1 Farming Economics in Has	3
2.1.2 Demographics and Geography of Goat Breeding in Has	5
2.1.3 Resources and their Effects.....	7
2.1.4 Opportunity with Has Goats for Economic Growth	10
2.2 Market Potential of the Hasi Goat	10
2.2.1 Rural Association Support Programme and Their Past Work with Goats in Albania.....	10
2.2.2 Specifics regarding the Hasi Goat Breed.....	11
2.2.3 Current and Growing Demand for Hasi Goat Products.....	11
2.3 Meat Processing and Production	12
2.3.1 Has Goat Meat Production	12
2.3.2 Commonly Used Drying Techniques	12
2.3.3 Additives / Flavoring Options.....	15
2.3.4 Factors Influencing Meat Preservation	17
2.3.5 Successful Goat Meat Production.....	18
2.3.6 Potential for Dried Goat Meat Production in Albania	18
2.4 Packaging	19
2.5 Standards and Promotion	20
2.5.1 Regulations and Safety.....	21

2.5.2 Geographical Indicator Marks (GI's)	21
2.5.3 Traceability.....	22
2.5.4 Branding.....	23
2.7 Challenges for the Success of Dried Meat	24
Chapter 3: Methodology.....	26
3.1 Documenting Existing Drying Practices.....	26
3.1.1 Safety and Quality Assessment Tool.....	27
3.1.2 Interviews regarding Tradition.....	27
3.1.3 Site Observations	28
3.2 Process Evaluations and Recommendations	28
3.2.1 Compiling and Comparing Practice.....	28
3.2.2 SWOT Analysis.....	28
3.3 Developing the Hasi Goat Brand.....	29
3.3.1 Marketing Focus Group.....	29
3.3.2 Identifying Potential Retailers.....	29
4. Results and Analysis	30
4.1 Observations and Opinions of the Current Drying Process	30
4.1.1 The Traditional Production of Hasi "Mish i Thatë"	30
4.1.2 Minor Variations in the Overall Process	32
4.1.3 Firsthand Observations of Slaughtering and Butchering Methods.....	33
4.1.4 Potential conflicts with health and safety standards.....	37
4.1.5 Specific Issues Regarding Product Safety.....	38
4.1.6 Areas for Product Quality Improvement	41
4.2 Lack of Measurement during Production	41
4.3 Farmer Interest in Selling Dried Meat.....	41
4.3.1 Desired Price of Hasi "Mish i Thatë"	42
4.3.2 Retailer of Interest and Potential Distribution Network.....	42
4.4 Potential Income	44
4.5 Insights on Promoting a Niche Product	45
4.6 Creating a Development Plan for the Hasi Goat Brand	46
5. Conclusions	48
5.1 Tradition is Consistent	48
5.2 Potential Impact of Measurements and Additives	48

5.3 Selling Dried Meat.....	49
5.3.1 Packaging Dried Meat	49
5.4 Potential Profits of Hasi "Mish i Thatë"	51
5.5 Promotion Plan for Hasi Goat Breed.....	52
6. Recommendations	53
6.1 Improving Product Safety and Traceability.....	53
6.2 Improving Product Quality.....	54
6.3 Development of the Hasi Goat Brand and Hasi "Mish i Thatë"	56
Works Cited.....	57
References	59
Appendix A: Initial Interview Questions	61
Appendix B: Updated Interview Questions.....	64
Appendix C: Individual Farmer Data Table	66
Appendix D: All Collected Farmer Data.....	68
Appendix E: Meat Expert Interview Notes.....	70
Appendix F: Marketing Focus Group Notes.....	74
Appendix G: Hygiene & Safety Criteria	75
Appendix H: Drying Pamphlet Produced for RASP	76

WARNING: Some of the figures in this report may be graphic to some readers. However, images depicting the process of slaughtering and butchering is valuable in understanding the traditional practice of producing Hasi "Mish i Thatë".

List of Figures

Figure 1: Villages interviewed (left) and corresponding goat densities (right)	v
Figure 2: Current, proposed, and potential distribution network	vii
Figure 3: This map highlights the Hasi region of Albania.....	3
Figure 4: Portion of families in the region who own goats. Given the sample size and population of the region, this is believed to be incredibly accurate. (Garnier, 2015).....	5
Figure 5: Number of goats per family (Garnier, 2015).....	6
Figure 6: A map of goat herd sizes and their distribution by village. (Garnier, 2015)	7
Figure 7: Man hours spent on various farming activities for a goat breeder over the course of year.(Garnier, 2015).....	8
Figure 8: Indicates the role agriculture and at various levels throughout the Has region. Garnier indicated that for goat farmers, commercial success increased with focus on agricultural activity. (Garnier, 2015) .	9
Figure 9: An adult Hasi goat foraging for food. (Dobi, n.d.).....	11
Figure 10: Simple sun drying technique (Heinz & Hautzinger, 2007)	14
Figure 11: Solar Tunnel drying apparatus (Heinz & Hautzinger, 2007)	14
Figure 12: Multi-collector drying apparatus (Heinz & Hautzinger, 2007).....	15
Figure 13: (Left) Semi-dry meat marinating. (Right) Final product after a second drying (Heinz & Hautzinger, 2007).....	16
Figure 14: Visual guide from FAO for simple vacuum packing of meat(Heinz & Hautzinger, 2007).	20
Figure 15: Overview of the process that guided methodology.	26
Figure 16: Steps within each part of the process.....	26
Figure 17: Timeline of the traditional meat drying process determined through group interviews	31
Figure 18: Red Markers in the right image indicate the villages of goat farmers interviewed. Interviews took place in villages with different environments and across the region but focused on villages with large numbers of goats.	32
Figure 19: Hasi goat intended to be used for Mish i Thatë.....	33
Figure 20: Washing of the Slaughtering Surface.....	34
Figure 21: Washing Hands and Tools with Soap and Water	34
Figure 22: Start of the Skinning Process - Removing Hooves	35
Figure 23: Hanging and Skinning.....	35
Figure 24: (a) Removing internal organs. (b) Goat carcass prepared for butchering	36
Figure 25: Cleaning of surfaces	36
Figure 26: Cutting slices for drying	37
Figure 27: Distribution model comprised of current, proposed, and recommended paths to market. ...	43
Figure 28: Distribution model of GI marked goat kid meat in Argentina (Vandecandelaere et al., 2010).	44
Figure 29: SWOT Analysis.....	46

List of Tables

Table 1: Potential yearly profit	vi
Table 2: Details of various drying techniques and associated information(Heinz & Hautzinger, 2007). ...	13
Table 3: Common ingredients used in meat processing (Santchurn, Arnaud, Zakhia-Rozis, & Collignan, 2012).	17
Table 4: Guidelines vs. farmer practice and potential hazards	38
Table 5: SWOT Strategy Matrix.....	47
Table 6: Variations, current safety measures and key improvements are simplified.	48
Table 7: The materials and properties of a plastic film RASP plans to use in packaging dried meat.	50
Table 8: Profits of dried goat meat	51
Table 9: Average yearly potential profit	52

Chapter 1: Introduction

Following the Albanian transition to democracy in 1991, emigration has grown as Albanians seek new economic opportunities in more developed areas. The Has Region of Kukes County in northeastern Albania has experienced some of the heaviest rates of internal emigration due to the lack of economic growth in rural, mountainous areas of Albania. According to the Albanian Institute for Statistics over 30% of the population of Kukes County emigrated to either other parts of the country or internationally in 2011 (Gjergji, 2014). Less than 2.6% of migrants return to Kukes County, making it the county with the lowest return rate in all of Albania (Gjergji, 2014). Those who stay within the Has Region rely heavily on remittances sent from family members working abroad; within the Has region 100% of 153 farming families interviewed in an intensive socioeconomic study received money from family outside of Albania (Garnier, 2015). This demonstrates the poverty and low economic standing of the Has Region when compared to a 2003 World Bank study estimating 22% of Albanian families benefit from remittances.

Income from remittances supplements agricultural income and is sometimes reinvested in farming enterprises – the primary activity of the Has region (Garnier, 2015). A popular economic activity in the area, goat husbandry, takes place on 178 farms and involves approximately 7,300 goats (RASP, 2014). These factors indicate that sustainable improvements in goat farming practices leading to increased economic opportunity could greatly benefit the region (RASP, 2014).

The sponsor of this project, Rural Association Support Programme (RASP), pursues opportunities for economic improvement; in this case RASP aims to utilize products from Hasi goats as an avenue for economic improvement. Turning current goat rearing practices into means of economic opportunity presents a daunting challenge since it involves "transforming agriculture from subsistence-oriented production into a modern, commercial, and competitive sector" (*Albania Program Snapshot*, 2015). RASP prepared to face these challenges by developing an initial strategy of introducing Hasi goat milk, meat, and cheese into markets. Since Hasi goat farmers are unable to individually develop and implement changes, RASP works with farmers throughout the region to develop animal products through a value added chain, eventually leading to the commercial market (RASP, 2014).

RASP has identified dried meat as an initial step in commercializing Hasi goat products. Safe animal origin products, especially those coming from mountain regions, are increasingly attracting consumer interest in Albania and the surrounding countries (RASP, 2014). The Has region has a long history of drying meat from older goats for familial consumption during the winter months. RASP sees the surplus of this

traditional product as an opportunity to develop a sustainable set of practices that would create value in the market.

This project aimed to provide RASP with recommendations on utilizing the traditions surrounding dried goat meat to create a desirable, marketable product that would result in increased economic opportunity in the Has Region. To achieve this goal three main objectives have been identified:

1. Determine the existing traditions surrounding dried goat meat within the Has Region.
2. Evaluate current practices with respect to identifying areas of potential growth and improvement for the drying process.
3. Develop the Hasi goat brand and recommend a promotion plan for dried goat meat.

Initializing change agents to improve the drying process and following the recommended steps to promote the Hasi goat brand will allow RASP to introduce Hasi goat products to the market. As the brand expands to include more value added products, adaptations to promotion and labeling can be made so that the brand is consistent among all Hasi goat products.

Chapter 2: Background

Initial work with the Hasi goat breed has shown that the development of quality control and product branding are two key aspects farmers may utilize to improve dried Hasi goat meat for revenue generation. This chapter first discusses the economics of goat farming and the demography of participants in the northeastern region of Has, highlighted in Figure 3, and considers the challenges farmers face in increasing productivity. To better understand the context of the project the chapter continues by presenting relevant meat drying techniques, noted elements of quality and safety, the use of herbal additives and spices, and options for packaging and labeling. Various quality marks are also examined to better understand the requirements of, consumer preferences for, geographically specific products, and the possible contributions to product branding. Finally, anticipated challenges are examined and how they might constrain and affect the project.



Figure 3: This map highlights the Hasi region of Albania.

2.1 Farming in the Has Region

Albanian farmers in the northern mountainous regions participate heavily in goat husbandry as part of the larger national trend in growing agribusiness. Development of more sustainable and productive goat husbandry - the main agricultural activity in Has - has the potential to significantly improve the regional economy. The Rural Association Support Program (RASP) has already begun capitalizing on goats to positively impact the livelihoods of farmers in the region (RASP, 2014).

2.1.1 Farming Economics in Has

Two French masters' students, Alice Garnier and Besmira Medolli, from the International Centre for Advanced Mediterranean Agronomic Studies program at the Institut Agronomique Méditerranéen de Montpellier performed intensive socioeconomic surveys to establish the Hasi goat farmers situation. This program trains executives of agriculture, food, and sustainable rural development in the Mediterranean. Working in conjunction with RASP, the two students each spent 8 months in the region over the course of two years and present a thorough understanding of the demographics, resources, and goat breeding practices of the area. Their studies included 153 of the 178 goat farms in the Has region, providing an incredibly accurate picture of goat husbandry in the region. Their observations and analysis are crucial to

understanding the farmers and their situations and what role this project will play in their economic ventures.

The farmers of the Has region face a number of challenges in improving their economic standing and goat breeding efforts. Chief among these is a diversity in the goals of each farm and their enabling factors. Not only do the goat-breeders not share the same aims regarding production, but neither are they endowed with the same factors of production which enable them to raise goats: access to pasture, the ability to produce fodder, labor, capital to cover expenses, access to markets etc. This results in variations in the size of the herds: some have few animals and use these for consumption and to supplement other activities, while by contrast others are specialized in breeding Hasi goats and raise large herds (Garnier, 2015).

Many reasons exist for the diversity in the farmers' practices and resources, while some of those are grounded in the nation's transition to capitalism, Garnier presents a number of other reasons such as high rates of emigration in the area and a high dependence on uncertain remittances from abroad. The combination of these two factors means that not only are the farmers shorthanded to perform the labor necessary for growth but do not have the financing to make larger investments with which to improve.

Labor here is often a free resource but is limited in many cases. Due to significant regional out-migration, families are dwindling. Children no longer want to take on the family farm. This resource is a key factor: it is often the main constraint which limits the activity of stock-breeding. A growth in the capacity of the labor force in a farm allows the following: a growth in the size of the herd; an increase in the production of fodder (if the land makes it possible); better production value; the possibility of climbing up into the summer pastures (Garnier, 2015). Seeing as the availability of labor limits economic success, dried goat meat seems to offer an opportunity to place added value on a high quality product with almost no change in labor demands. The monetization of dried goat meat would involve little change on the part of the farmers and would provide a supplementary income that could be used as capital to make small and necessary improvements to the overall goat husbandry efforts. This however does not ignore the fact that in order to find larger success the farmers would require a larger source of labor which could depend on increases in capital.

2.1.2 Demographics and Geography of Goat Breeding in Has

Understanding the traditions involved in the goat meat drying process, quality improvements, and brand development requires a deeper knowledge of the participants and who would benefit from these activities. Despite the prevalence of agriculture and livestock in the region only three percent of families surveyed by the Garnier and Medolli team were involved in goat husbandry at some level. This can be seen in Figure 4. Given that a 2011 census indicates there are about 17,500 people in the Has region it is likely that their sample size of 5,013 families is pretty complete (Gjergji, 2014). RASP's work indicates there are 178 farms in the area, therefore represents a sizeable portion of the region's people. These farmers have varying levels of education as well as differing sizes of goat herds. Relevant data on Albanian farmers can be found in a survey performed by faculty members in the Department Of Animal Production at Agricultural University of Tirana to identify tendencies on farms rearing local goat breeds (Dobi, Hoda, & Labinoti, 2011). Generally the goat farmers on average are just shy of 57 years old and have a mean of only 8 years of formal education. Often farms consist of a large household in order to have all the necessary labor to care for the farm. On average, there are 12-20 people on the farm, though 6-10 actively help with the farm (Garnier, 2015). A number of the farm activities surrounding goats and cows, (another popular form of livestock) are time consuming and involve significant man hours. This indicates increased income would significantly improve the famers' situation by providing greater access to labor.

Portion of Families Possessing Goats (5013 Families Total)

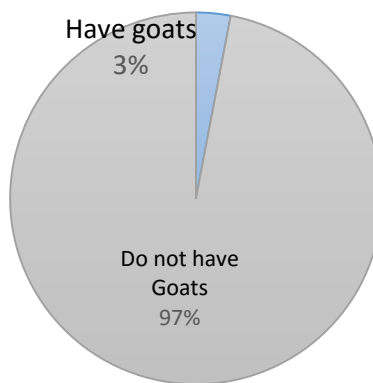

Figure 4: Portion of families in the region who own goats. Given the sample size and population of the region, this is believed to be incredibly accurate. (Garnier, 2015)

The average goat farmer surveyed owns 1.47 hectares of land with an average of 31% of that space covered in foraging area. These farmers own other animals as well: 41% also own sheep and 74% also own cows as a part of their husbandry efforts. The 178 goat farms collectively have an estimated 7,300 goats,

of which 6,000 are Hasi goats. Kukes County, (of which the Hasi region is a smaller area) has a total of 1270 goat farms and 28,000 goats. Most of the farms in the Has area are smaller, on average have only 41 goats, 70% of these farms have between 5-50 animals. Some farms produce dried meat with the goats that are too old or sometimes the ones that are not sold (RASP, 2014).

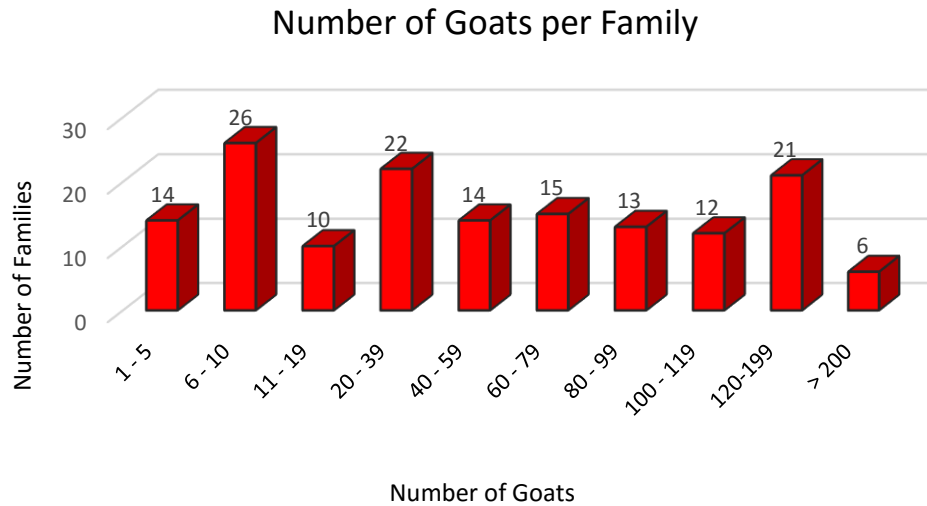

Figure 5: Number of goats per family (Garnier, 2015)

The various sizes of farms that can be seen in Figure 5. This figure demonstrates the idea that the farmers are in a number of different situations in relation to their use of goat breeding as an economic activity. The locations of certain farms mean they are better suited to larger scales of production, due to increased access to pastures and water sources reducing in those cases the need for additional labor. The Karst Plateau is home to the most dense goat activity, but Figure 6 illustrates the sizes and distribution of farms throughout Has.

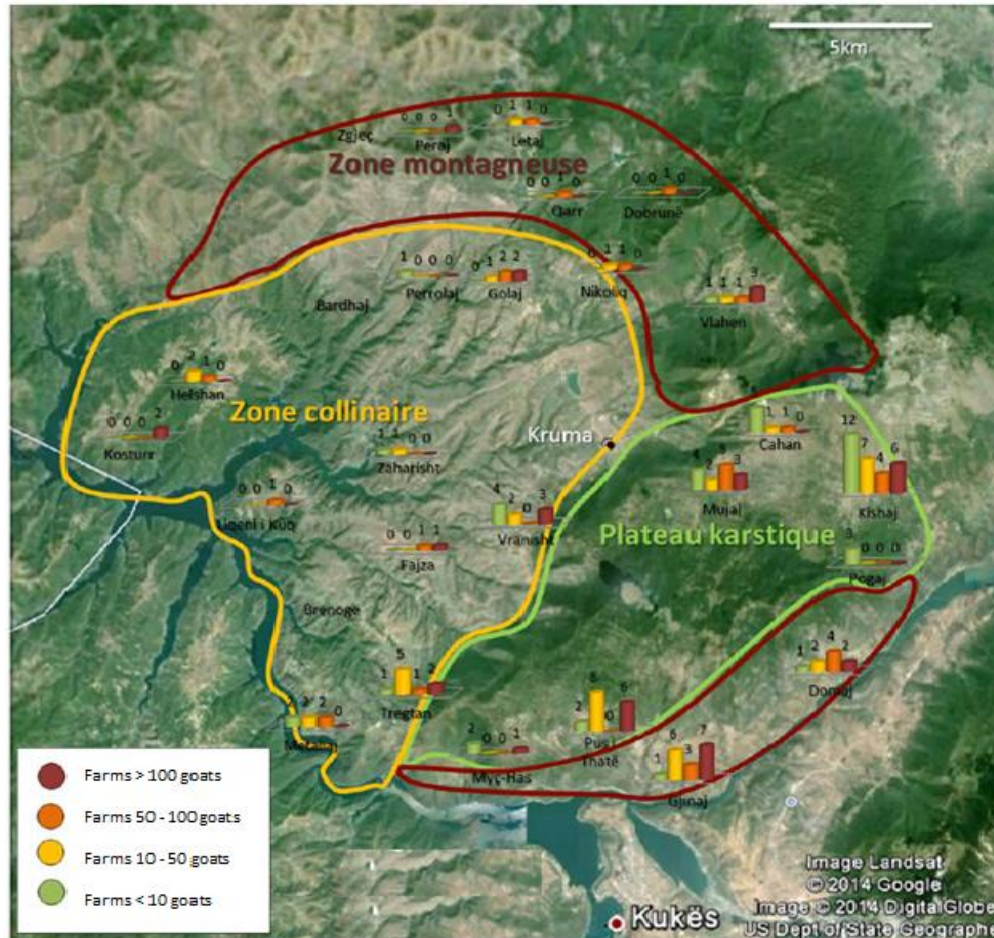

Figure 6: A map of goat herd sizes and their distribution by village. (Garnier, 2015)

The availability of these resources such as water and grazing area rather clearly lead to the development and success of the larger farms seen on and surrounding the Karst Plateau in Figure 6. Larger farms might require more labor to maintain the herd size and production capabilities. An increased scale of production often means the larger farms are better connected to meat traders and other markets, realizing better commercial success. These larger farms have been the target of RASP’s initial efforts, however smaller farms are also welcome to participate if interested.

2.1.3 Resources and their Effects

A number of aforementioned resources make up the capital of the region’s farmers, these include both human and natural resources. Human resources are directly tied to capital through labor and its importance to success as seen in Figure 7 where the availability of labor is a determining factor. However, it must be emphasized that money coming from abroad, remittances, play a primary role in the economy of the Has families: the amount of remittances sent by one or more members of the family working abroad

is high. In fact, Alice Garnier reported that she did not meet anybody in Has who did not have at least one member of their family sending money to their family who had remained in Has. Garnier then proceeded to indicate that a 2003 World Bank study estimated that 22% of Albanian households benefited from these remittances. This indicates a strong dependence on the irregular remittances for pushing beyond familial economic subsistence, which may allow for the occasional investment.

Man Hours per Month on Agricultural Activities

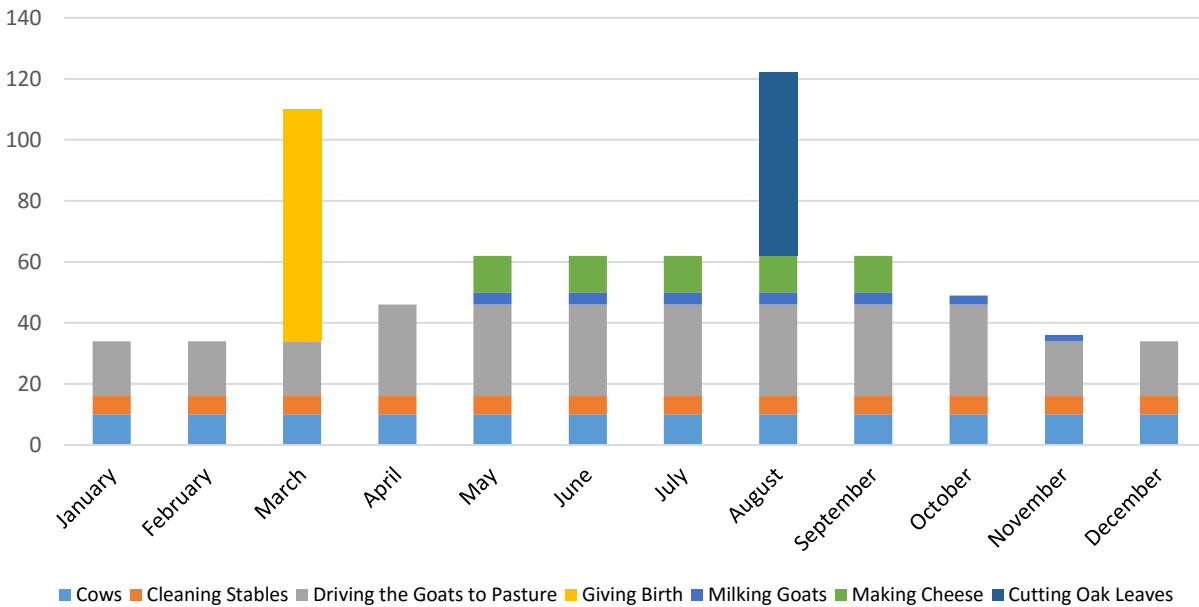

Figure 7: Man hours spent on various farming activities for a goat breeder over the course of year. (Garnier, 2015)

Between raising animals as a supplementary source of food and raising animals as the primary income-generating activity there are a multitude of intermediate cases specific to each household, which are presented in a schematic manner in from left to right in Figure 8. These cases highlight the difficulties the farmers face but also indicates that the Has Goat Breed Association will help fill a void in order to find future success. These advantages and situations outlined throughout the chapter leave labor as one of the primary difficulties the farmers will encounter moving forward.

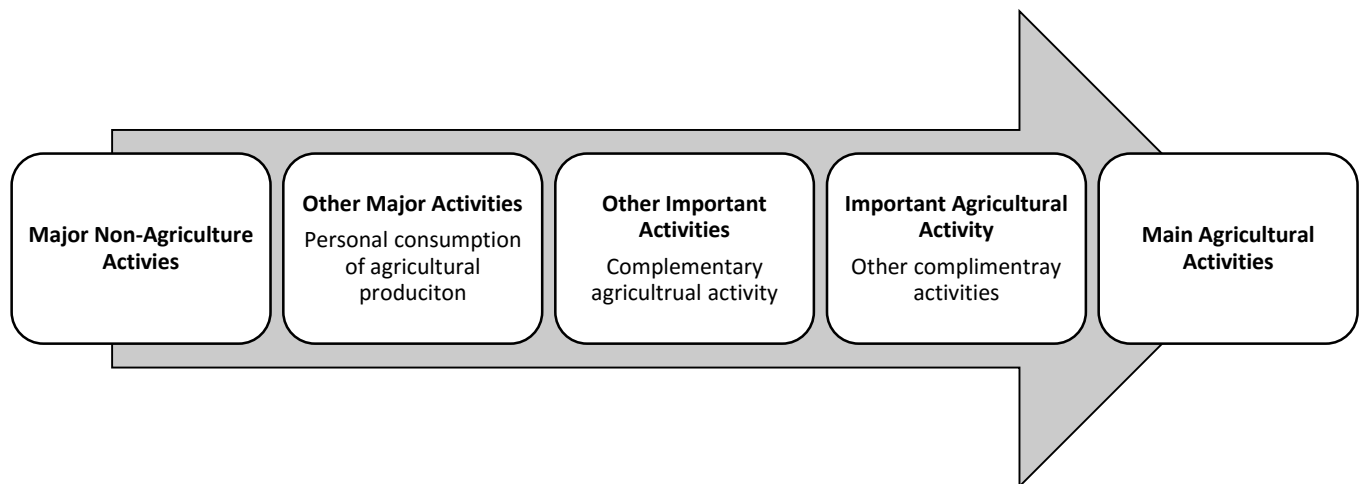

Figure 8: Indicates the role agriculture and at various levels throughout the Has region. Garnier indicated that for goat farmers, commercial success increased with focus on agricultural activity. (Garnier, 2015)

The size of the herd is an important distinguishing criterion for success outside of economic survival because it is correlated to the importance of the breeding at the heart of a system of activities. If there are under 50 head of breeding goats, goat-breeding is not on its own a viable activity: it is rare that this would not be combined with another activity (farming or non-farming). Among these are included the herds consisting of less than 10 breeding goats, whose products are mainly for the household's consumption and sold on an occasional basis, constituting a small supplementary source of income. A herd of more than 50 head of breeding goats can become an income-generating activity which sustains the needs of a family on its own. A herd of more than 100 head of breeding goats represents a significant income-generating activity, more rarely associated with another activity, and one which could be called specialized breeding.

Above 100 head of breeding goats, (L per head of breeding goats). This is generally the principal activity of the breeder or his family, because it provides a substantial income. These are often the farms with a strong labor force and medium to strong agricultural capacity (especially the ability to produce fodder), and/or considerable capital for labor or fodder.

Medolli argues that the greater number of goats a breeder has, the easier it is to sell them (as cited in Garnier, 2015). Essentially, the big goat breeders (specialized or non-specialized) have easier access to the circuits of direct sale such as restaurants, meat traders, or butchers, which enables them to sell their goats at a better price than if they went to the meat market. Moreover, the meat market is limiting because not only does the farmer pay for transport to (a particular difficulty for more remote or disadvantaged villages)

but equally, it is an uncertain market outlet where the farmer must pay an admission fee without being sure he will sell his goats. The commercialization of goats depends not only on physical access to markets but also on access to consumers, which greatly depends on the quantity of goats for sale.

2.1.4 Opportunity with Has Goats for Economic Growth

Goats are one of the easiest animals to feed and maintain both worldwide and in Albania. Additionally, they are an excellent resource for a number of products. To better understand the value of the Hasi goat and the natural environment it thrives in, an anecdote from Garnier's interviews provides a key insight. "The milk of the goats of Has is like gold. No, it's better than gold: it's like a medicine! If you smell the breath of a goat that has come back from pasture, it smells like a pharmacy...Here there are goatherds who, aged 100, still climb up into the mountains on foot, they're in such good shape!" (a goatherd in the village of Vlahen). This anecdote indicates a high value is placed on the Has goats and their products ranging from milk to dried meat.

The survey by researchers from the Agricultural University of Tirana indicates that farms receive more income from goats than any other livestock and that 59% of goat farmers consider goat meat production their main priority and farms with over 50 heads receive around 73% of their income from goat products (Dobi et al., 2011). Smaller scale farmers have a lower income per goat than that of larger farms. This could be attributed to infrastructure, making it even more important to develop infrastructure to increase the income per goat. Capitalizing on low labor products and improvements such as the dried meat of older less desirable goats is an excellent way to accomplish this (Dobi et al., 2011). Garnier suggests that the Has goats have strong potential for a Geographic Indicator (GI) mark which could enhance the value of its products without a large increase in labor required (Garnier, 2015).

2.2 Market Potential of the Hasi Goat

2.2.1 Rural Association Support Programme and Their Past Work with Goats in Albania

RASP seeks to ultimately improve the livelihoods of those in rural areas through education and the development of local products by actively involving the population in the environment and local economy. The Hasi goat has been identified by Dr. Petrit Dobi, the executive director of RASP as a viable source of income in the Has region of Albania due to the high quality and nutrition found in goat milk and cheese (Dobi et al., 2011). RASP has been gathering data on the Has goat and the context required to pursue projects for the breed. The goats involved in analysis prior to this project were used primarily for milk, cheese, and the kids for meat production. The results indicated the Has goat is a "good source of income

for the local population." RASP seeks to create value of goat products and promote meat production (Dobi, 2015).

The project's further success is dependent on the navigation of a number of obstacles. Most of these difficulties are tied to lack of support or access to credit, distribution networks, quality control and hygienic standards for processing and packaging. To facilitate these improvements RASP has helped the farmers organize into an association, the Hasi Goat Association (HGA).

2.2.2 Specifics regarding the Hasi Goat Breed

"The Hasi goat is a typical goat breed of northern Albania, mostly found in the district of Has, Kukes. This breed is well known for its adaptation to harsh environments. The Hasi goat has a well-developed body, strong legs and well developed udder. They are excellent browsers in oak forest, oak-hornbeam forests, evergreen forests and shrubs, etc. These animals are a good source of income for the local population thanks to their high quality milk and cheese, [which are] low in cholesterol and high in nutritional values" (RASP, 2014). The Hasi goat is a recognized breed, distinct with its reddish long hair and horns that curl sideward in females, and larger and curled in males. These goats are used for their milk and meat. Females produce 150-250 liters of very rich and high quality milk each year. As a large goat, at full size, females are 55 kg, and males are 65-70 kg (RASP, 2014).



Figure 9: An adult Hasi goat foraging for food. (Dobi, n.d.)

2.2.3 Current and Growing Demand for Hasi Goat Products

Preexisting husbandry practices and the efforts of RASP demonstrate the profitability of goat meat in northeastern Albania. Hasi goat products are already being exported to Kosovo where products from this high quality goat are often requested (RASP, 2014). Additionally, the meat traders from various regions in

Albania have been increasingly interested in Hasi goat meat. Traders from Durres and Kukes have become interested in buying Hasi goat kids, taking them to destination markets, and slaughtering them on site where the fresh kid meat is then sold. This kid meat can be sold at a price of 400-420 L per kg of meat at the destination markets in areas such as Tirana and Kosovo.

2.3 Meat Processing and Production

The development of new revenue streams for farmers is a main priority. RASP is seeking to promote dried goat meat as a vehicle to generate additional revenues for goat producers. The following section examines possible goat meat production techniques in detail. The section provides context for Hasi "Mish i Thatë" and production methods by considering various techniques presented in literature from RASP, the Food and Agriculture Organization of the United Nations (FAO), and other agricultural researchers.

2.3.1 Has Goat Meat Production

Dried goat meat has market potential in Albania and the surrounding regions if it can be made more appealing through different drying techniques and flavor enhancements. Currently, the method of drying goat meat after it is slaughtered produces poor quality meat. If done correctly however, dried goat meat can be "very tasty and it is used to create a variety of dishes" (Dobi, n.d.). People in Albania and the surrounding regions like goat meat for its high nutritional content, at 21.5% protein and 1.95% fat and its taste, something between lamb and beef (Costa et al., 2011).

Basic infrastructure for this meat production also exists since farmers in Albania already have goats that are used for milk production until they age and are slaughtered for personal meat consumption. Currently, farmers use kids (preadolescent goats) ranging from 2-9 months of age for commercial consumption, and adult goat meat is often dried at home and stored for familial consumption. The addition of better drying techniques and a value added process would allow farmers to generate additional revenue using these older goats.

Within the Has region there are 7,300 goats split amongst 178 farms with a mean herd size of 41. There are some outliers within this process however, with 70% of farmers having less than 50 animals and 5% having more than 100. Yearly turnover within flocks is around 80-100 kids for a flock of 100 (RASP, 2014).

2.3.2 Commonly Used Drying Techniques

There are various drying or preserving techniques already used in Albania and the surrounding regions. The processes each have their merits and each affects the quality of the meat in a different manner. The variety of methods also require a range of technology in order to preserve the meat ranging from the

simple, requiring sticks and string, while others require more technical apparatuses. A few examples of small-scale methods highlighted by FAO can be seen in Table 1.

Table 2: Details of various drying techniques and associated information(Heinz & Hautzinger, 2007).

Process	Equipment Needed	Average Time to Dry	Materials Cost	Difficulties
Sun Drying	Wood or metallic frame or drying trays 14% salt solution	8-10 hours for a thickness of <1cm	Low/no cost	Possibility of contamination due to drying out in the open
Solar Tunnel Drying	containment chamber corrugated aluminum sheet fans solar panels drying trays	48 -96 hours	Approximate cost US\$1000	Expensive and possibly difficult to successfully set up
Multi-collector dryer	containment coop corrugated aluminum sheet wood frame drying trays	48-96 hours	Low cost	Entire dryer requires a large area

On one end of the spectrum, a frequently utilized method in larger commercialization efforts is the complex method of preserving meat through thermal treatment. Conventionally, thermal drying of meat involves large rooms equipped with environmental controls and moving hooks for hanging meat. Thermal treatment preserving is designed for environments with higher volumes of goats, higher capital, and further stages of commercialization.

On the opposite end of the spectrum is solar drying - one of the oldest meat preservation methods. The majority of Albanian mountain farms use this process. Solar drying can come in many forms, but is generally described as the gradual dehydration of pieces of meat cut into a specific uniform shape. Solar drying techniques are defined as the drying of meat under natural temperatures, humidity, and circulation of air, including direct influence of sun rays ((FAO), 1990). This treatment of the meat reduces the meat's water content rapidly enough that no bacterial spoilage can take place, even though temperatures remain high. Solar dryers may be as simple as hanging the meat from sticks in the sun (Figure 10) or can be a more complex process. Various methods of increasing complexity may involve such as aspects as a roof above the drying area, or siding made of netting to allow for air flow but reduce contaminants, examples can be seen in Figure 11. The cabinet solar dryer is a more complex solar dryer, "where warm air is conducted

through a hermetically closed chamber, and thereby avoiding any undesirable impacts from the outside” (Heinz & Hautzinger, 2007). This method seems to fall nicely in the middle of the spectrum.

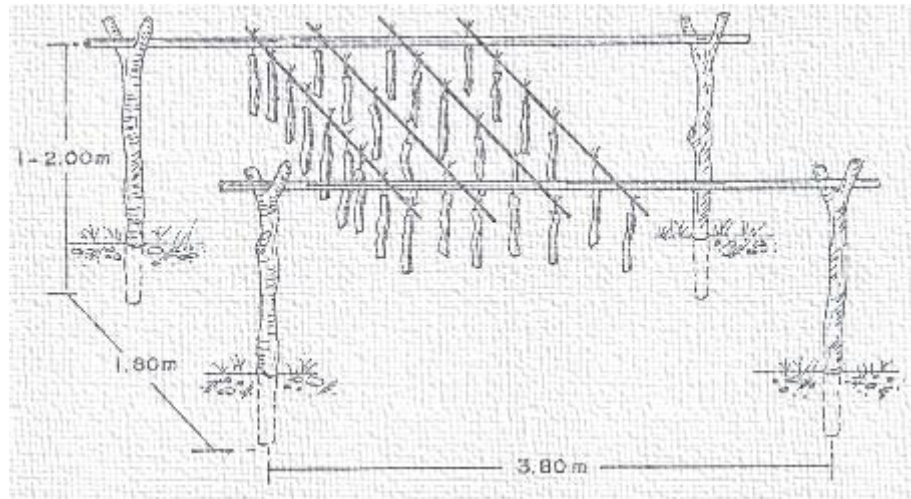

Figure 10: Simple sun drying technique (Heinz & Hautzinger, 2007)

Solar drying is a simpler method due to the ease of obtaining the necessary materials. The construction materials for the solar tunnel dryer are relatively cheap, simple and can be produced locally. Simple solar drying can be done using sticks and twine, which are both cheap and easy to obtain. It can also be made more permanent by using metal tubing for the structure that the meat hangs from to dry. Solar drying is more time consuming to prepare than most methods, as each strip has to be cut and then twine must be tied to each one so that they can be hung.

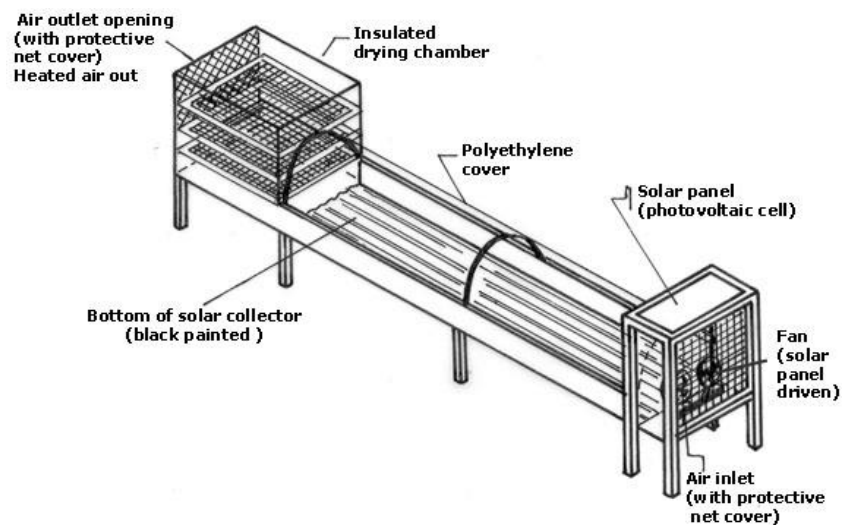

Figure 11: Solar Tunnel drying apparatus (Heinz & Hautzinger, 2007)

On the more advanced side of the solar drying spectrum, the multi-collector dryer (Figure 12) utilizes the heat produced by the sun, collecting it on aluminum sheets that direct the heat into a screened-in container where the meat sits on drying racks. This process usually takes about two days to complete drying. The tunnel solar dryer is similar to the multi-collector dryer, where “high energy inputs from the sun are achieved through a long solar collector ("tunnel") using electric fans”. This method has a drying time of about two days as well. The tunnel dryer in Figure 11 costs between 1000 – 5000 USD to implement (cost depends on the power usage of solar panels in the given design). The fans used to provide air circulation require some sort of power source, solar panels are often used. Both the multi-collector dryer and the tunnel solar dryer have the advantage of being able to leave the meat out at night, and it will continue to dry. These apparatuses dry the meat on racks, so less time is required to prepare the meat for drying. Each method and technology has its own merits.



Figure 12: Multi-collector drying apparatus (Heinz & Hautzinger, 2007)

2.3.3 Additives / Flavoring Options

Potentially one of the areas for greatest improvement is in the use of flavorings to improve the quality of the taste, appearance and texture of the meat. One popular flavoring option practiced in Africa on beef and goat is adding flavors partially through the drying process. Solar drying is used to semi-dry the meat, then the meat slices are soaked in a flavorful marinade for several days. Common ingredients for the marinades include water, salts, garlic, spices, onions, and oils. Since meat is often soaked for an extended period of time, the slices are able to fully soak up these flavors. After soaking, the meat needs to be dried again and the preferred secondary drying method is heat treatment. Although the meat has a high water concentration after soaking, five minutes over a fire reduces the water content to 10-15% which is low enough to allow for a long shelf life (Lloha, 2015).



Figure 13: (Left) Semi-dry meat marinating. (Right) Final product after a second drying (Heinz & Hautzinger, 2007)

Besides the use of marinades for taste there are a number of additives that can be used to improve texture, safety and appearance. Certain plant enzymes can be used to soften meat and prevent the usual hardening of meat that occurs in drying, keeping meat more tender and thus more attractive to consumers. In addition, small quantities of nitrites can be applied to maintain meat color, keeping the meat a bright red as seen with chipped beef (Youling, 2012). A list of common additives can be seen in Table 3: Common ingredients used in meat processing (Santchurn, Arnaud, Zakhia-Rozis, & Collignan, 2012). Table 3 below. Several herbs found in the Has region may also be used to improve taste. Local available seasonings are sage, thyme, Winter Savory, and paprika which can be used to improve the taste and safety of the meat.

An intensive study examining the effects certain spices as meat additives concluded that the addition of oil and paprika decreased the amount of coliforms, yeast, and mold present in the meat - so this additive can be used as means of extending shelf life. Paprika has a significant effect on reducing bacteria since the spice is characterized by strong antimicrobial effects against pathogens, and can be a means of increasing the safety factor of the final meat product (Cherroud et al., 2014). These additives can help create a product that is both of high quality and safe to consume and allows the farmers to better profit from their work.

Dry curing is another way to apply flavoring. This process is a little more involved since the meat must be rubbed with a mixture of salt, sugar, and nitrates at least two times a day throughout a 3-5 day drying process .

Table 3: Common ingredients used in meat processing (Santchurn, Arnaud, Zakhia-Rozis, & Collignan, 2012).

Common Ingredients Utilized in Meat Processing		
Ingredient	Example	Main Function
Salts	NaCl, KCl, LiCl, CaCl ₂ , MgCl ₂	Flavor; protein solubility; protein functionality; meat hydration
Phosphates	Na ₃ PO ₄ (ortho-), Na ₄ P ₂ O ₆ (pyro-), Na ₅ P ₃ O ₈ (tripoly-), (NaPO ₃) _n (hexameta-)	pH stability; protein extraction; water-holding; meat hydration
Alkalis	NaHCO ₃ , alkali phosphates	Protein extraction; meat hydration
Acids	Citric acids, malic acid, lactic acid, acetic acid	Protein extraction; meat hydration
Curing agents	Nitrate, nitrite, erythorbate	Cured meat color (pinkish-red); flavor; antimicrobial
Nonmuscle proteins	Soy protein, sodium caseinate, protein hydrolysates	Extender; filler; texture; water-binding
Polysaccharides	Carrageenan, xanthan, Konjac flour, starch	Water-binding; emulsification
Enzymes	Bromelain, papain, ficin, transglutaminase	Meat tenderness; meat-binding; texture of restructured meats
Seasoning	Paprika, black pepper, fennel, cumin, garlic	Flavor; antioxidant; antimicrobial
Health ingredients	Vegetable oils, protein hydrolysates, rice bran	Nutrition; health

2.3.4 Factors Influencing Meat Preservation

The shelf life of meat products is influenced by various endogenous (from inside) and exogenous (from outside) factors such as pH, moisture (aw), oxygen, microorganisms, light, and temperature. When processing and packaging meat these factors are often tested as means of assessing shelf life and safety of the final product. Lower pH and aw values increase the shelf life and reduce the growth of microorganisms (Heinz & Hautzinger, 2007). Understanding different categories of microorganisms and bacteria is crucial to assessing preservation since certain categories of microorganisms negatively affect the product by causing spoilage or pathogen growth while others positively affect the product by causing desired texture changes and decreasing the nutrients available to harmful bacteria (Cherroud et al., 2014).

Lactic acid bacteria and Gram-positive catalase-positive cocci are two microorganisms commonly found in meat during processing and can be used to increase preservation. Lactic acid increases the safety of the meat and can be optimized through a shorter processing time. However, Gram-positive catalase-positive cocci, which prevents spoilage and increase the visual and aromatic appeal, increases with a longer maturation time (Cherroud et al., 2014). Considering the growth of these beneficial bacteria as well as how they prohibit harmful microorganisms will be important in assessing processing techniques that optimize shelf life and product value.

While endogenous factors are largely affected by processing techniques, packaging selection conditions the impact of exogenous factors. Packaging that decreases oxygen and light permeability is best for preservation. As meat is exposed to more oxygen, oxidation and rancidity of fats begins to occur which causes both unappealing color changes and spoilage. As exposure to light increases, the energy provided accelerates these processes.

A general guide for stable dried meat products at ambient temperatures is having a pH lower than 5.2 and water activity (a_w) ranging from 0.75–0.50 (Heinz & Hautzinger, 2007).

2.3.5 Successful Goat Meat Production

Successful kid meat markets exist in across Mediterranean region due to the high nutritional value of goat meat (Teixeria, 2011). The yield of meat from an older goat is higher than the yield from a kid however, as the goats increase in age their meat becomes less desirable since tenderness decreases (Costa, 2011). Countries such as Spain, Italy, and Brazil have been curing older goat meat through a salting and drying process to produce *cecina* for over 2000 years and currently *cecina* is considered a top quality cured meat (Teixeria, 2011). Studies in these areas highlight the benefits of a salting process since salting or smoking is more suitable for the tougher meat of older goats.

Longer salting times result in both the best microbiological and physicochemical meat results (Cherroud, 2014). Longer cure times directly correlate to meat tenderness and ease of tearing pieces from the final product (Teixeria, 2011). One article contradicted this finding, claiming longer salting time resulted in a tougher piece of meat. The same study also concluded that the reduced water content of a longer salting time had a positive effect on the meat (Lorenzo, 2015). This decrease in water saturation is important for the long term preservation of the final product since lower moisture values increase the shelf life.

Depending upon drying times or additives present in meat, drying techniques can be altered to find a method that results in "high levels of good microbes and low levels of harmful microbes" (Cherroud, 2014). The general trend was that an increased salting time better prevented harmful microbial growth by reducing the presence of coliform bacteria, yeast, and mold (Lorenzo 2015; Cherroud, 2014).

2.3.6 Potential for Dried Goat Meat Production in Albania

As summed up by Cherroud, "consumers demand safe, additive-free food of high nutritional value. In this sense, a dry-cured Halal goat meat product is the best choice to enhance goat meat and produce a product without chemical additives" (Cherroud, 2014). Since farmers in the Has District currently cut and dry meat, the basic background for dried goat production already exists. Methods currently used involve

stringing meat, salting it and hanging it to dry. Currently farmers in the Has region use no modern equipment or flavoring in the drying process (P. Dobi, personal communication, September 18, 2015). By applying the additives and techniques discussed earlier the product can be markedly improved with little increase in cost or skill set. These potential improvements will allow farmers to market a desirable product to consumers.

2.4 Packaging

Increasing a product's shelf life while maintaining proper physical and chemical characteristics is the main purpose of packaging. Type of packaging, storage air conditions, pH, and a_w are all factors that influence the quality of dried meat storage (Hui, 2012). Since dried meats already have a low pH and a_w , they are inherently shelf-stable. This means the longevity of storage is highly dependent on the packaging system.

There are two primary types of meat safety that must be considered with packaging choices – oxidative safety and bacterial safety (I. Lloha, personal communication, November 6, 2015). Minimizing the chemical deterioration of dried meat, while unavoidable, should be the focus of a packaging system. Proper packaging reduces exposure to heat, light, and oxygen, thus decreasing lipid oxidation and lowering the rancidity of meat (Hui, 2012). Bacterial safety, which refers to mold growth on the product, while still important, is a lower priority in packaging selection since any surface covering reduces bacterial growth (Hui, 2012).

When packaging dried meat products, such as Charque, vacuum packaging in plastic is a commonly used method since it effectively preserves the meat and is an easily implemented process (Hui, 2012). Vacuum packaging removes oxygen, thus decreasing chances of rancidity, and depending upon the sealing material the impacts of light and heat can also be reduced. A simple guide for vacuum packing can be seen in Figure 14. Tests on the effectiveness of transparent biaxially oriented polypropylene laminate (BOPP), semi-transparent BOPP, and polyethylene-polyamide (PE-PA) laminated showed the PE-PA is the most effective material to preserve the quantitative and qualitative characteristics of dried products under vacuum conditions (Shakouri, 2015). Polyethylene-polyamide is successful in further preserving these ideal characteristics since it is gas-impermeable (Hui, 2012).

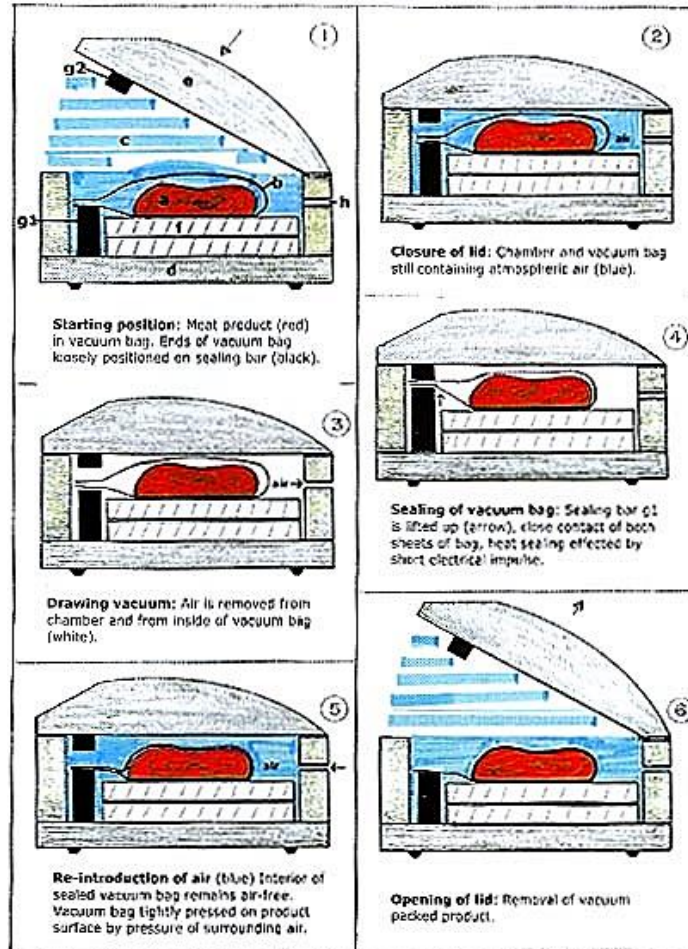

Figure 14: Visual guide from FAO for simple vacuum packing of meat(Heinz & Hautzinger, 2007).

2.5 Standards and Promotion

Dried goat meat is not a popular commercial product in Albania and little research exists on the subject and consumer preferences. Interviews of those with firsthand knowledge indicate that dried goat meat is typically consumed either locally or within the household and is rarely sold. This means that few consumers are aware of the product outside the regions where it is produced. This provides an excellent opportunity to define the product. The objectives of documenting the tradition, making improvements, and promoting dried goat meat all incorporate a refined product definition as part of the core idea. Using the documented traditional practices as a baseline, recommendations of best practice and their context are outlined in the following section. The following presents a general overview of necessary knowledge for defining such a product as well as relevant quality and safety standards.

2.5.1 Regulations and Safety

Something that consumers stressed when deciding on important aspects of the meat they purchased is the production process of the product as well as the quality control (Bernues, 2003). Many people in Albania are accustomed to buying from their local butcher and trust his or her opinion over that of a government regulatory body or grading agency (P. Dobi, personal correspondence, Sept. 24, 2015). Given a lack of large scale traditional products, inconsistency and less rigorous safety standards may present difficulties for dried meat commercialization. These aspects listed as highly important for the consumer, indicate that success of the traditional food product depends on the recognition of the brand and the accompanying definition of quality (Byrne, Waehrens, & O'Sullivan, 2013). An emphasis on the means of production and the brand's adherence to standards through traceability and hygiene criteria will allow the consumers to recognize and trust the product leading to a higher likelihood of profitability.

Albania has been working on improving the legal framework and infrastructure for food regulation. The National Food Authority was in 2009 established to help the country meet EU standards. These efforts are in line with the country's goal of joining the EU and ensuring that many relevant laws are up to date with world practices. The marks created require approval from the Ministry of Agriculture. However, all of the quality standards the National Food Authority is working to establish are voluntary. Currently homemade products such as dried goat meat need few certifications to be sold. Funding through the Instrument for Pre-accession Assistance of the EU Albania has also been established as means to help implement regulatory systems such as the Hazard Analysis Critical Point Control (HACCP) and Good Manufacturing Practice (GMP) (FAO, 2011). Such practices will become increasingly important at Albania moves towards the EU.

In addition to acquiring a government regulated quality mark, the Hasi Goat Breed Association is working to register a branding mark that is meant to promote the Hasi goat breed and associated products. This mark would be similar to a trademark and would show that the product met standards established by the association that improve the quality of the Hasi meat (P. Dobi, personal communication, September 18, 2015).

2.5.2 Geographical Indicator Marks (GI's)

A mark of geographical indication is a designation assigned by the European Union. There are three types of GI marks that EU can assign, Protected Designation of Origin (PDO), Protected Geographic Indication (PGI), and Traditional Specialty Guaranteed (TSG).

RASP is interested in pursuing a PDO which means that all production and processing needs to occur in the identified region, currently defined as Has. The other two marks are PGI where most but not all of the process should occur in the given region and TSG is associated with the traditional methods but not necessarily a region. The PDO mark RASP is interested in is for dried meat, but there is interest in further registration for not just dried meat but a number of Hasi Goat products. Such GI marks are shown to help a product gain traction in a market and have been shown to command a significant selling price over similar products without a similar mark. A review of various literature with a focus on the economic perspective of GI marks indicates that meat products usually command a price of 1.8 times that of similar products without the GI certification (Hajdukiewicz, 2014).

While studies show such marks have clear benefits they often come with many difficulties in standardizing practices, associated development costs, and continuous promotional developments in order to find success. This project hopes to further the understanding of dried goat meat and develop the Hasi goat breed brand in order to facilitate changes which will improve the socio-economic situation of the farmers and possibly other actors involved in Hasi Goat products (Byrne et al., 2013).

2.5.3 Traceability

In order for farmers to obtain the mark of the association and for the Hasi Goat Breed Association to meet corresponding standards, rather rigorous adherence to and documentation of the given standards is necessary. Traceability is major part of both of the GI mark, and its associated quality, but is also crucial to product safety. An understanding of what is being done to produce a processed meat product, even if done naturally, is important for general safety and quality. As a general definition this extends from breed of animal, food and water sources, the size and cut of meat, to type and concentration of additives. A number of standards offer definitions of traceability but the EU General Food Law (Regulation [EC] No. 178/2002, Article 18 paragraph 1) states, “‘Traceability’ means the ability to trace and follow a food, feed, food-producing animals or substance intended to be, or expected to be, incorporated into a food or feed, through all stages of production, processing and distribution” (EU General Food Law, 2002). Traceability measures can be used to improve both the food safety and animal health as well as the quality of the product and process.

While the difficulties in implementing an effective traceability scheme are complex and many of those challenges fall outside the scope of this project it is important to acknowledge that the objectives of this project help lay a preliminary framework for further success of dried goat meat and the Hasi Goat Breed in general. By using documented traditions as a baseline, the objectives surrounding improvements and

branding can be fulfilled. A set of FAO case studies indicates that traceability will help, “manage risks related to food safety and animal health issues; guarantee products’ authenticity and give reliable information to customers; and improve product quality and processes” (Germain, 2003). Results of a well-intentioned foundation in traceability would be highly beneficial to farmers and serve both the objectives of safety improvement and promotion.

2.5.4 Branding

Consistent brand development and appealing products are necessary for RASP to find success with Hasi Goat products in the long term. Defining not just the geography and practices but the sensory qualities and the story associated with the product have been shown to play a role in promotion of such a niche product and will therefore be key consideration in development of the Hasi Goat brand (Toften & Hammervoll). Cultural context and a constant definition of product are indicated as strong factors consumers consider in such food products. Two studies discussed in an article of the *Journal of the Science of Food and Agriculture* regarding *Future Development, Innovation and promotion of European Unique Food* indicate that deeper understanding of consumer preferences while “aiming to preserve the identity of unique products, keeping in mind that they were developed and evolved in a specific cultural context” (Byrne et al., 2013). The same paper indicates that, “it is crucial to give traditional producers the means to produce safe products as small producers experience technical and financial difficulties in complying with official food safety regulations.” By creating a brand that consumers associate with high quality and selective taste and a cultural story, the Hasi Goat Breed Association will likely be able to find success. This will involve the process of clearly defining for the association what it means for a specific product, in this case dried meat, to be of the brand’s quality. This will be crucial to not only development of the product but will aid the region on a larger scale, “it is a key way to ensure the survival of local economies with positive effects on employment and environmental protection” (Byrne et al., 2013).

Among Albanians domestic goat meat is of much higher value than that of imported varieties, and this signifies opportunity for RASP and their long term efforts regarding Hasi goat products. Consumers place focus on the meat being "local" in origin (AIDA 2009). Even within the country however, there is another factor that makes the Hasi goat more valuable. Highland goats specifically, those raised in the mountainous outer regions of the country, are considered to have better meat and can obtain prices much higher than that of imported or lowland, domestic varieties (Imamia, 2011). Better meat, a greater cultural story and health benefits indicate added value for a product. Defining the brand and associating

quality with each Hasi goat product will increase the likelihood of product success. This indicates that there is potential for Hasi Goat products in Albania if the brand can be created and properly maintained.

2.7 Challenges for the Success of Dried Meat

Overall consumer awareness of the product serves as a significant barrier to profitability of the dried meat. Those familiar with goat meat generally consider older goats rather undesirable due to its tougher texture, flavor, and the prevalence of strong muscle fibers. Dr. Ilir Lloha from the Biotechnology Department at the Agricultural University of Tirana explained that these characteristics are much more prevalent in the fresh meat of the older goat and nearly unnoticeable in dried meat and fresh meat of younger goats (I. Lloha, personal interview, November 6, 2015). Market knowledge is limited with dried meat, and might be a significant barrier to profitability of the product outside of consumers and markets tied to the region.

Various pieces of research suggests the best way to market and sell traditional food products is through the development of a brand based on natural values. Circumstances due to geographical and traditional factors of production play a key role in crafting such a product definition. Byrne highlights the importance of tradition in food production, “a clear understanding of local food heritage and the key elements in defining a food’s uniqueness will assist in preserving... [cultural] knowledge that can be passed on to the coming generations.” This focus on cultural preservation is similar to RASP’s mission and the goals of this project. This project faces a challenge of possibly adopting varying standards and traditions across a region in order to best tell the story of the product to improve its potential profitability. Byrne, Waehrens, and O’Sullivan makes that case that findings should be brought in the context of cultural and economic benefits, with a view to promoting sustainable agriculture and rural development where unique food is under-defined (Byrne et al., 2013).

The sensory qualities and traceability mentioned previously make up a small portion of the much larger context in which the traditional food practices of drying goat meat need to be evaluated. The challenges with the proposed goals include the reception of changes in practice. Common practice dictates that such changes would be motivated by economic incentive. Currently market knowledge is narrow and a niche product might have little demand, therefore little economic incentive for farmer participation. The Hasi Goat Breed Association may face difficulty establishing codified practice. Standardizing practice may enable these developments or prove to be a financial roadblock in the improvements or changes to the process.

Interviews with the sponsoring organization indicate dried goat meat supply chains do not extend outside of a localized area even when high prices are present in more urban environments. Nevertheless, RASP

has previously completed projects in helping develop products and facilitate market access. Creating dried goat meat as new commercial product rather than aiding with improvements will however, be a first for the organization. A lack of financial resources, infrastructure, and market knowledge will provide barriers for successful commercialization of the product.

Chapter 3: Methodology

The goal of this project was to utilize the traditions of dried goat meat to create a desirable, marketable product that would result in increased economic opportunity in the Has Region. To achieve this goal, three objectives were identified:

1. Determine existing traditional practices of drying goat meat in the Has Region.
2. Evaluate current practices and identify potential for improvement of the drying process.
3. Develop the Hasi goat brand and recommend a promotion plan for dried goat meat.

This chapter describes the methods used to gather information from experts and stakeholders, analyze potential improvements to the process, and develop recommendations for promotion. Ultimately, these steps, outlined in Figure 15 and Figure 16, lead to an initial plan for selling dried goat meat in the commercial Albanian market.

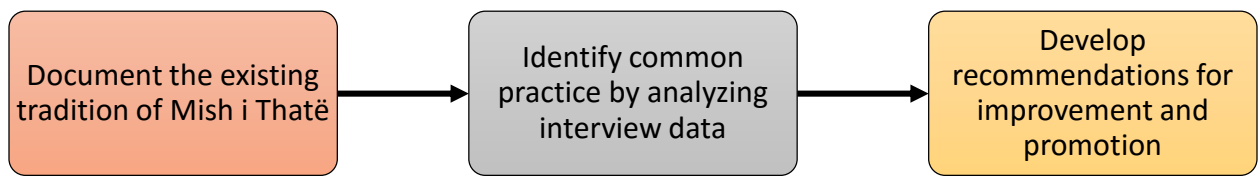

Figure 15: Overview of the process that guided methodology.

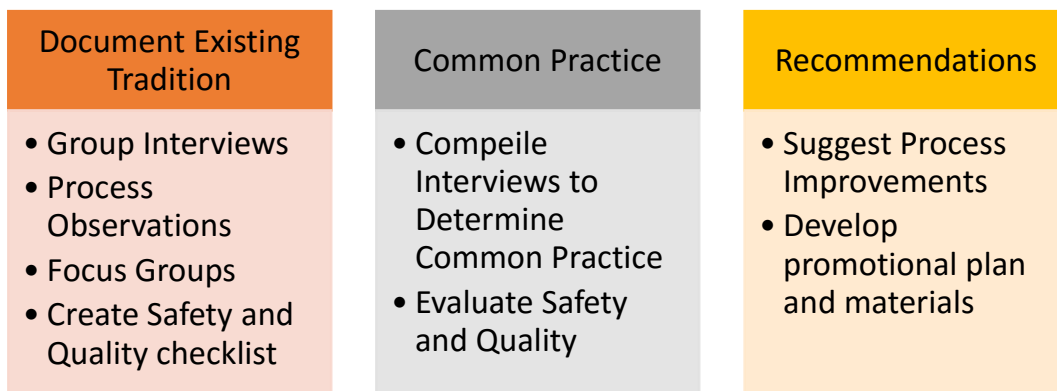

Figure 16: Steps within each part of the process

3.1 Documenting Existing Drying Practices

Objective one was to **determine existing traditional practices of drying goat meat in the Has Region**. In order to provide any improvements or recommendations the team needed to understand the history and

tradition of the process. Documenting current drying practices established context to analyze potential improvements and assess farmers' resistance to change. Multiple farmers within the HGA were interviewed since goat farmers throughout Has have varying levels of production and access to resources.

3.1.1 Safety and Quality Assessment Tool

In order to improve process safety and codify practice the team developed safety and quality criteria using published standards and an interview with an Albanian food processing expert, Dr. Ilir Lloha. This criteria, utilized as a checklist for monitoring practice during the visit, encompassed key aspects of standard safety practices recommended by experts, standards, and guidance documents. The criteria and sources used to develop it can be found in Appendix G: Hygiene & Safety Criteria. Background knowledge obtained through the development of the safety criteria and preparatory work then guided the interview questions and areas of focus for onsite observations.

3.1.2 Interviews regarding Tradition

Due to the constraints of limited time and opportunity to meet with farmers, only eight farms were represented in the interview process; however, farms from a variety of backgrounds were visited to best understand the region as a whole. RASP selected an initial sample of goat farmers from the HGA that would be good candidates for understanding the tradition and development of dried meat in the region. Farms selected for interviews were from the three villages with the largest goat population to provide the most accurate data on traditions surrounding dried goat meat. Interactions between the students and farmers was not a barrier since the farmers were comfortable working with RASP.

Interviews utilized an ethnographic data collection technique of theoretical sampling “where sampling decisions about further collection of data are driven by the state of the data analysis” (Flick, Metzler, Scott, & Gale Virtual Reference, 2014). Outlined in *The SAGE Handbook of Qualitative Data Analysis, 2014*, this technique was selected to best understand traditions due to the methods of translating emerging concepts into a stronger and more representative sample. Theoretical sampling begins with “an initial round of sampling to generate ideas, [then] your next choice of person, site or situation is driven by the need to develop and elaborate on your emerging conceptual ideas. In grounded theory terms, you undertake theoretical sampling to help develop codes and categories, to understand variation in a process, to saturate properties of categories and to integrate them.” After eight farms from HGA had been interviewed both the team and RASP felt that the sample size sufficiently represented regional practices for larger farmers interested in the initial stages of dried meat commercialization. Villages from dissimilar parts of Has were used to ensure that practices from across the region were recorded.

An initial questionnaire guided the first interview, detailing the practices from feeding and goat selection to butchering and common manners of consumption. The full questionnaire can be found in Appendix A. Individual data not representative of the entire village was recorded separately in the table shown in Appendix C.

Responses from the first interview guided the slight modification of the questionnaire used in subsequent interviews. This updated interview sheet can be found in Appendix B. The table in Appendix C was still used for data collection in all interviews. This table focused on quantitative data in order to compare farms at a later date. A member of the sponsoring organization based in Kukes County was later able to collect the above mentioned data from farmers not interviewed, the raw data can be found in Appendix D: All Collected Farmer Data.

3.1.3 Site Observations

The team was present too early in the season for the usual timing of the drying process and the majority of farmers were not ready to complete the drying process. This meant the team was only able to observe the process once. The team documented every aspect of the process through notes, adaptive questioning and photos. This observation was followed by a sampling of already dried meat and an open ended interview with the Chairman of the Hasi Goat Association (HGA). First hand observation and in depth discussions of the plans for HGA's use of dried meat highlighted the focus of the farmers and their efforts.

3.2 Process Evaluations and Recommendations

The second objective was to **evaluate current practices and identify potential for improvement of the drying process**. This objective was fulfilled by comparing interviews, analyzing the safety and quality of onsite observations, and conducting a SWOT analysis of the collected data.

3.2.1 Compiling and Comparing Practice

To ensure that common practice throughout the region was fully encompassed, the villages visited were mapped and interviews were compiled to create a preliminary code of practice. Results of the onsite observations were compared to standards and methods of good practice identified by Dr. Lloha and written FAO industry standards. The team evaluated the onsite observations using the safety criteria, standards, and follow-up discussions with the sponsoring organization.

3.2.2 SWOT Analysis

Based on methods outlined in a FAO guide for promoting quality linked, geographical indicated products, SWOT (strengths, weaknesses, opportunities, and threats) analysis was selected as an analytical technique for product development (Vandecandelaere, Arfini, Belletti, & Marescotti, 2010). The team conducted a

SWOT analysis specific to dried goat meat with Prof Assoc. Dr. Petrit Dobi. This analysis utilized findings, interviews, and the onsite observations to determine areas of improvement and growth for the product. Strengths and weaknesses of dried meat relating to current practices were identified first. Next, the team brainstormed potential external factors that could act as opportunities or threats while trying to develop dried meat for the market.

After the initial matrix was created each category was refined to highlight the most important factors. Analysis of the relationships between key factors in the given categories highlighted specific strategies for improvement; this primarily focused on using strengths and opportunities to diminish weaknesses and threats.

3.3 Developing the Hasi Goat Brand

The final objective was to **develop the Hasi Goat brand and recommend a promotion plan for dried goat meat**. This objective is necessary to promote Hasi Goat Products and morph dried goat meat from a product used only for familial consumption into a valued product in the market. Focus groups with marketing students were conducted to provide background information on marketing that was then adapted in the designs and promotional plan.

3.3.1 Marketing Focus Group

The team conducted a large, informal focus group with a class of MBA students at the University of Tirana to gain advice on marketing dried goat meat. Discussion topics were focused on consumer market demographics and promotional strategies. Main discussion questions used to lead the group and gather information were:

- Have you heard of or eaten dried goat meat?
- What groups of people would be most interested in dried goat meat?
- How would you recommend marketing dried goat meat?

3.3.2 Identifying Potential Retailers

Dr. Petrit Dobi and a number of the interviewed farmers had investigated potential links to markets. They did this by identifying retailers in the town of Krumë, located in Has, and the town of Lezhe, located 60 km north of Tirana. The Chairman of the association described the model for distribution he believed would be most feasible for HGA and the team compared this model to the FAO Guide for promoting geographically indicated products (Vandecandelaere et al., 2010).

4. Results and Analysis

4.1 Observations and Opinions of the Current Drying Process

Interviews conducted with farmers in the Hasi region were compiled, analyzed, and compared to understand the traditional methods of drying goat meat. These interviews provided an in-depth view of the processes throughout the region. Interviewees expressed that the current drying process is simple and largely uniform between villages. A pattern of common practices was observed with every farmer utilizing the same techniques with minor, usually superficial, differences; thus the traditional drying practices are consistent throughout Has.

4.1.1 The Traditional Production of Hasi "Mish i Thatë"

Hasi "Mish i Thatë" is traditionally made in each families home with simple tools and methods. Details such as how the goats are raised contribute to the method and quality of the final product. Growing up grazing in the mountainous pastures means that the goats only eat herbs, leaves, and grasses present in the area. As a result, the taste of these natural herbs contributes to the taste of Hasi goat meat. The close interaction of farmers in raising goats means that they know when a goat is sick, lame, or unable to produce milk. These factors are then taken into consideration when selecting goats to be slaughtered for drying.

Mid-December and the onset of winter marks the start of the drying process. Interviews with eight farmers showed that a single farm tends to slaughter 16-18% of their general flock numbers. Additionally, the common tendency is to slaughter two to three times as many kids as older goats. Kids are slaughtered earlier in the season for fresh meat, but old goats are slaughtered in these winter months with the intent of being dried.

All farmers interviewed slaughter and butcher the goats at home in an outdoor or kitchen area. This portion of the process is where the most variation occurs. Farmers will cut the neck and allow the blood to drain for 5-30 minutes, then different farms will leave the goat to sit or hang for different amounts of time. Some will hang the goat for 15-20 minutes and then leave it to sit for two hours before butchering begins. Others hang the goat for 15-30 minutes then immediately begin the skinning and butchering process.

When butchering the goat the farmers interviewed all followed similar sanitation methods. Not one farmer said that they washed the carcass with water. When asked, they said that washing would rid the meat of the good flavor or cause undesirable color changes. Although carcass washing did not occur, good sanitation practices of washing the butchering knives with hot water and soap were common.

Uses for each part of the goat remained relatively consistent from farmer to farmer. Internal organs and portions of meat unsuitable for drying (such as the neck and head) are eaten very soon after butchering. Strips of meat meant for drying are cut to approximately 50 cm long and 2-3 cm wide, but may be shorter depending on what part of the goat they come from. All farmers stated that leg meat is the best for drying because it is a long section of good meat without joints.

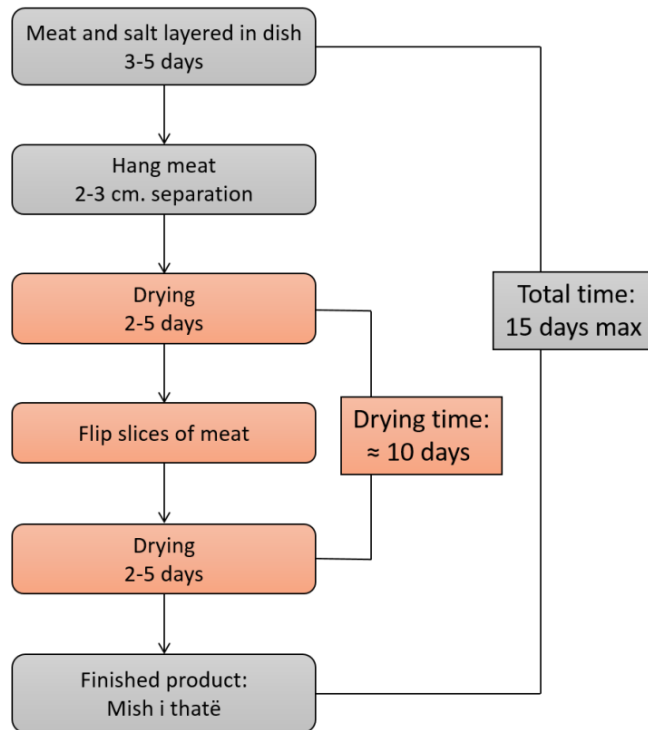

Figure 17: Timeline of the traditional meat drying process determined through group interviews

Figure 17 shows the complete salting and drying process, which may take up to 15 days and takes up the largest portion of time when producing Hasi "Mish i Thatë." The meat is layered with approximately 4-5 kg of salt per 100 kg of meat. During interviews the team found that the amount of salt varies since no farmers take measurements, instead they made approximations based on experience. The meat remains in salt for 3-5 days and then is hung over wires or ropes with 2-3 cm separating each piece. This separation allows for airflow between the strips which expedites the drying. Meat will hang for 2-5 days before being flipped and dried for an additional 2-5 days. During this process some farmers open windows during the day to allow fresh air flow and most keep a stove or fire in the room with the drying meat to prevent it from freezing and to reduce the moisture in the air, which also improves the drying process. To test if the meat is done drying all farmers said they twist the meat; if the piece breaks they know it is dry, if it does

not break they leave hanging for a few more days. Once the meat is completely dry, it is taken down and stored in a burlap sack that is left hanging in the kitchen throughout the winter.

These methods are the traditional way of producing Hasi "Mish i Thatë." Sons learn the method from their fathers through observations and oral instruction and the tradition is passed down from generation to generation. Observations and pieces of interviews indicated that women help with the slaughtering by preparing and cleaning surfaces or supplementing the primary activities of the process (such as flipping the slices and testing if the drying process is complete). When asked about changes in the process, farmers stated they had never tried any other way of drying meat because "this is the way it has always been done."

These interviews, conducted in the three villages across the region as seen in Figure 18, provided a variety in geography and terrain. Although all three villages lie in the southeastern portion of Has, they provide an accurate representation of the tradition throughout the region since they correspond to villages with the highest goat populations (approximately half the region's Hasi goat population).

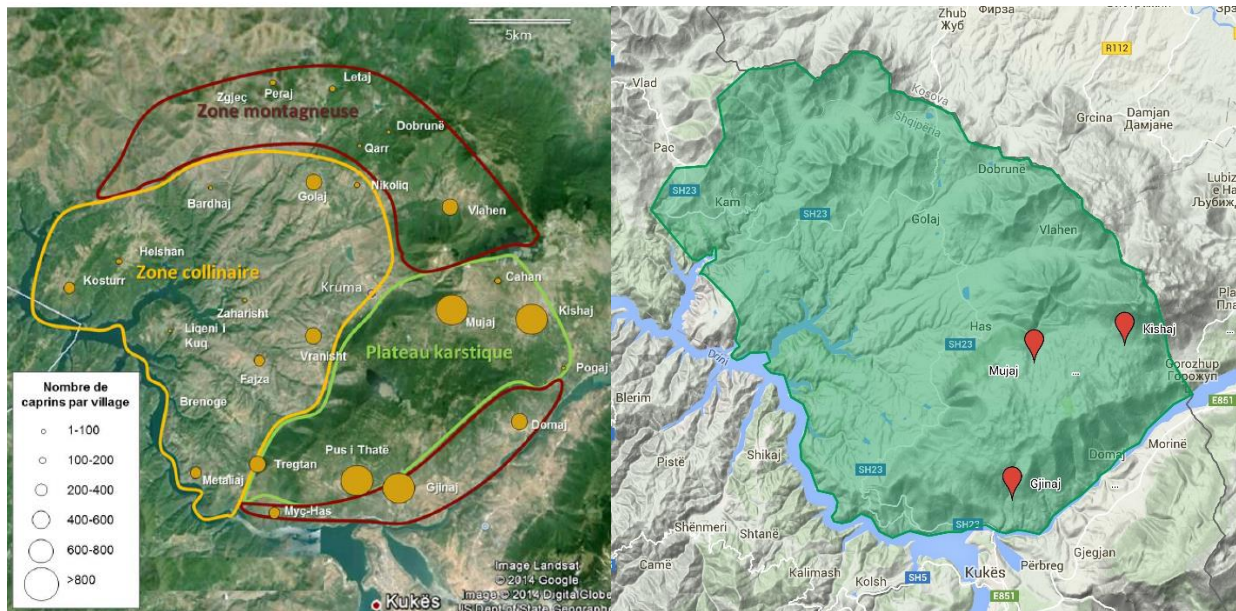

Figure 18: Red Markers in the right image indicate the villages of goat farmers interviewed. Interviews took place in villages with different environments and across the region but focused on villages with large numbers of goats.

4.1.2 Minor Variations in the Overall Process

Variations identified during interviews occurred in the slaughtering and butchering processes. The clear differences noticed in interviews were carcass hanging times, the ratio of salt to fresh meat, and hygienic practices based on the facilities and equipment available on each farm for meat drying. The difference in

carcass draining time revealed that this part of the process lacked any form of scientific guidance and led to farmers having some variation in this step of production. Carcass hang time could vary from 15 minutes to 2 hours. Ratio differences of salt to fresh meat also had high variation ranging from 4:100 to 8:100 of kg salt to kg meat, additionally many farms simply not measure salt and could not provide approximations.

Discussions following the lack of salt measurement revealed that the majority of the drying process is uncodified and rarely measured aside from a mental checklist for most farmers. Analysis of other interviews indicated that while some farmers were aware of their general practices, descriptions beyond approximations and generalizations could not be obtained. The lack of precision serves as a strong indicator that traceability and standardization should be codified to facilitate improvements.

4.1.3 Firsthand Observations of Slaughtering and Butchering Methods

After initial data collection through interviews, the team visited Mujaj village to observe the slaughtering and butchering process. Observation occurred at Kastriot Dajçi's home (Chairman of HGA). Other stakeholders in the project who were present include: Muharrem Xhebexhia and Ali Muja (both goat farmers and the Secretary of HGA and head of Mujaj Village respectively), and Sadik Xhafa Head of Hasi Agriculture Sector. Normally one person from the home will slaughter and butcher the goat, however since this was the first slaughter of the season and the team was there to view, a few others were invited to take part in the process.



Figure 19: Hasi goat intended to be used for Mish i Thatë

Only one goat, pictured in Figure 19, was slaughtered during the trip. The goat was four years old, younger than the average slaughter age of seven, but was chosen since she had stopped producing milk. Ten days prior to slaughter the local veterinarian performed an ante mortem inspection to ensure the goat was in good health. The day before slaughter feeding of the goat also ceased, so the last time the goat ate was 15 hours earlier. Slaughtering occurred outside on a cement platform in the yard. The goat was held down, a cut was made on the neck, and the goat was left to bleed out and stop moving for a few minutes. During this time the slaughtering surface was rinsed with potable water, as seen in Figure 20, and all of the farmers washed their tools and hands using soap and water from the family's drinking water storage container, as seen in Figure 21.



Figure 20: Washing of the Slaughtering Surface



Figure 21: Washing Hands and Tools with Soap and Water



Figure 22: Start of the Skinning Process - Removing Hooves

Once the goat was no longer moving, skinning began. While the goat was still lying on the cement the horns and hooves were removed, as seen in Figure 22 to avoid any possible contamination of the meat from materials residing on the goat's hooves. After these initial steps the goat was hung by its legs from a beam near the house. Skinning continued while the goat was hanging, as seen in Figure 23.



Figure 23: Hanging and Skinning



Figure 24: (a) Removing internal organs. (b) Goat carcass prepared for butchering

After skinning was complete, an incision was made in the abdomen and the internal organs were removed. This was entirely done by hand, as seen in Figure 24a, using very delicate motions so that none of the internal organs were ripped or punctured. All of the internals were collected in a single bucket, separated from the hooves and hide which were placed in a wheelbarrow meant for waste. Once the internal organs were removed the goat was ready for butchering, a fully prepared goat carcass is shown in Figure 24b.



Figure 25: Cleaning of surfaces

While the men were preparing the goat for butchering, women were often cleaning the trays and surfaces. Throughout the slaughtering process the surface around the goat was frequently cleaned and the blood was swept away, as shown in Figure 25. The stump used to chop meat, the table used to pile strips for drying, and the trays used to collect meat that would be kept fresh were all washed using potable water. Once the goat and trays were ready, butchering began. Slices for drying were cut from the torso as seen in Figure 26. Pieces from the leg were also chopped into long segments. These pieces were about 50 cm long, as was expected based off of interviews. However, the width was more within the range of 2-5 cm instead of the expected 2-3 cm farmers talked about during interviews. When cutting slices the fat was also left on, as previously explained by farmers.



Figure 26: Cutting slices for drying

4.1.4 Potential conflicts with health and safety standards

Following observations of the entire slaughtering and butchering process, the team compared current methods to safety and quality criteria developed based off of industry standards. These FAO standards and expert suggestions highlighted quality, hygiene, traceability, and capacity as areas of focus. Dr. Lloha specifically suggested the team focus on sanitation and hanging time. These comparisons to industry standards regarding quality and hygiene were identified by the team as some of the most important

aspects of a commercialized product. A number of problems with the current system were identified as well as areas that, while non-critical to safety, could be improved. A summary of these findings can be seen in Table 4: Guidelines vs. farmer practice and potential hazards.

Table 4: Guidelines vs. farmer practice and potential hazards

FAO Guidelines	Farmer Practice	Identified Hazard from Difference
Perform Ante-mortem inspection	Regular checks with veterinarian	Animal is not checked immediately before slaughter and could be sick
Perform Postmortem inspection	Not performed formally, observations were made during butchering	Animal is not formally checked for sickness prior to butchering
Organ Removal done by hand	Organs removed by hand (without gloves)	Exposes farmer to animal and vice versa
Tools and Hands frequently washed with soap and potable water	Washed with soap and potable farmer frequently	None
Non-porus surfaces used for butchering	Cement and log used as primary surfaces	Possible contamination
Clean cuts from bone	Particular cuts were imprecise and bone shards left	Possible bone shard ingestion
Safe environmental controls	Farmers depend on air temperature for safety	Not fully contained, and air temperature not measured
Secure environment	Screened windows and solid door, but in living quarters	Both residents and meat are exposed to increased contaminants

4.1.5 Specific Issues Regarding Product Safety

During the slaughtering process good efforts were made given the environment, but overall the process was lacking in areas of quality and sanitation. Although there was frequent washing of hands, tools, and surfaces, there were additional aspects of food safety that did not seem to be monitored. The Animal Production and Health Division of FAO recommends in the *Manual of Good Practices for the Meat Industry* that animals have ante-mortem and postmortem inspections, however the interviewees indicated that post mortem inspections never occur. Since there is only one veterinarian for the area it is common for

goats to be checked on a monthly basis while they are living, but farmers mentioned it would be too difficult to have a veterinarian perform postmortem inspections as well.

It was also brought to the team's attention that there is currently only one veterinarian in the Has Region. Due to the large number of farms with difficult accessibility, the veterinarian waits for requests rather than making regular visits to the farms in the region. During the onsite observation, a member of the Hasi Municipality's agricultural division revealed that this veterinarian that provides care to animals is also the competent person (certifying body) with the ability to provide certifications of good animal health. The second municipality veterinarian left a few months earlier and a replacement has not been found. Although the drop to one veterinarian is recent, this conflict of interest is of additional concern since a veterinarian certified clean bill of health for the animal is all that the Albanian Government requires for this type of food production.

Facilities available to the farmers also play a large role in both development and safety of the product. Surfaces on which slaughtering occurred were quickly identified as a part of facilities that did not meet industry guidelines. The cement surface used for slaughtering and initial butchering is porous, so although the surface was frequently cleaned, the team is unsure of how sanitary the surfaces actually is. However, the goat only lay on the cement surface prior to skinning so no consumed meat should have been exposed. A large block of wood was also used during this observation for butchering. While cleaned beforehand, the team felt safer surfaces with a lower likelihood of harboring bacteria exist. Acknowledging that farmers might not be able to possibly acquire a significantly better surface, the team recognizes that in the given environment surface improvements may not be feasible.

Meat intended for consumption only became exposed to the environment while the goat was hanging. Throughout this portion of the process the nearby areas were frequently washed with water and other farm animals were kept away from the fresh meat. The use of potable water for cleaning these surfaces appears sufficient since meat never comes in direct contact with the surfaces around it. Food safety while the goat was hanging was furthered due to the time of year meat drying occurs. Farmers stated that normally the colder air found later in the winter was a primary factor in preventing smaller pests and microorganisms from contaminating the meat.

Although colder weather act as a deterrent to pests, no supplementary preventative methods of pest control were observed. This observation was not too surprising since during interviews the only response to pest control was that the cold weather means they are not an issue. Additionally, meat spends a limited

amount of time outside. Once butchering is finished, the meat is moved inside to rooms that are sealed to outside by doors and screen covered windows. Farmers interviewed also expressed knowledge of this safety aspect and assured the teams all windows were screened during the drying process to prevent contamination.

In addition to environmental hygiene, the onsite observation paid particular attention to tool and hand sanitation. Hands were frequently washed with potable water, sometimes hot and sometimes cold depending upon availability. Tools were usually washed with hot water and antibacterial soap. However, both tools and hands were dried on the farmers' clothing which did not appear to be clean.

While butchering the meat, the team noticed a cleaver being used to cut sections into strips for drying. Underneath the section of tissue was a large bone which broke off into the meat when hit with the cleaver. This, in addition to the discovery of a small piece of bone in the sample of dried meat, indicated that the farmers should find a safer method of separating bone and meat prior to cutting the flesh into strips.

Washing the carcass, a recommendation by Dr. Lloha, was another step not practiced by farmers. A 10-30% salt solution was recommended to wash the carcass surface to kill any bacteria before proceeding with butchering. However, since the meat is not left hanging to rest for the 12-24 hours, as Dr. Lloha recommends, there is not much time for bacterial growth on the surface. Additionally, the meat is kept in salt for 3-5 days before drying occurs, so bacteria and microbes would be killed during this salting time. Taking the lack of exposure outside and the salting time into consideration, washing with a salt solution may not currently serve as a necessary or beneficial process.

Although the team was unable to observe meat hanging, when visiting the room used for hang drying and asking about the process it appeared that the meat was left uncovered. While the room was separated from the outside by windows and a door, it appeared to be a family room that was frequently exposed to the outside. Per Dr. Lloha's recommendation of covering meat to prevent contamination, additional observation of the drying process may be needed to assess the frequency of exposure during drying.

Many of the observations relating to food safety depend upon the environment in which the slaughtering and butchering process occur. One aspect of the process that the team will be unable to change is safety in terms of the environment. The location in which farmers slaughter and butcher goats will realistically not change, a fact of which RASP is aware. However RASP is working on raising farmers' awareness of safety throughout production and hopes to apply relevant standards.

4.1.6 Areas for Product Quality Improvement

Regarding quality, Dr. Lloha expressed that one of the best and easiest ways to create a more tender product was to allow the carcass to pass through rigor mortis - allowing the meat to relax prior to butchering. For an adult goat it may take 24-48 hours to complete this process. The goats slaughtered to be dried in the Hasi district are given significantly less time to relax their muscle tissue, typically less than 2 hours, potentially leading to a tougher product. The team acknowledges that while this may produce a lower quality product, the region lacks available facilities to store meat for extended periods of time so requesting farmers to do so may result in reduced safety of the product.

Improving quality through small hygiene changes, such as a larger separation during hanging, was another method recommended by Dr. Lloha. Current practice is to hang slices of meat approximately 2 cm apart. Lloha recommended hanging slices 10-15 cm apart, with the reasoning being to decrease the drying time. If the hanging time of the meat was lowered, then hygiene would improve due to less time for potential contamination.

4.2 Lack of Measurement during Production

Interviews suggested a lack of empirical measurements in the process of production. This finding was supported by onsite observations where no farmers were seen using any measurement tools. The team asked farmers whether they might use a thermometer for ascertaining whether the air was cold enough for drying or measuring the temperature of the drying room and if scales were used at any point in the production process. All of the farmers asked explained they “just knew when the time was right and that they had a good idea of the amount produced.” When team members expressed concern over the lack of measurements the regional coordinator explained that “every farmer knows his goats as well as his children,” suggesting there is a high degree of skill despite the lack of empirical measurements.

Production numbers were always provided as estimates with the minimum values often being as large as the estimated range. Some of this may be attributed to yearly variance, but when questioned further indicated a lack of measurement. When asked how they determined their production numbers, farmers responded by explaining that their lifelong knowledge of goats, their weights, and personal understanding of the process informed their production estimates.

4.3 Farmer Interest in Selling Dried Meat

Interest in selling dried goat meat exists within the population of farmers interviewed by the team. It was also expressed that other farmers in the area would be willing to sell Hasi "Mish i Thatë" if the market was available. Farmers are interested in selling outside of the Has Region since families within the region have

means of producing their own dried meat. However, to appeal to the tastes of people living in cities farmers believe adding herbs may be necessary. Discussions with the Chairman and Secretary of HGA indicated that while consumers in the Has region would like the dried meat without additives, they felt additives would help sell the product in more urban areas. They believe that consumers without ties to the region would find the product more appealing and that it would increase market size and interest. Overall, there is a willingness to sell individually or together depending upon what is best for the market and what would result in the best price.

4.3.1 Desired Price of Hasi "Mish i Thatë"

Farmers' desire to sell their surplus of dried meat is dependent on the ability to make a profit. Old goats, having a live weight of 55 kg for ewes and 75 kg for rams, can be sold at markets in Kukes or Kosovo for 15,000 L. A ram may produce up to 15 kg of dried meat and a ewe up to 11 kg of dried meat. In order for breeders to produce and market dried meat rather than selling a live goat, a price of 1000-1360 L/kg for dried meat would be necessary to break even. However, since producing Hasi "Mish i Thatë" requires additional time and resources so the farmers' minimum desired price is 2,000-3,000 L/kg. Since dried beef sells for 4,000-4,500 L/kg in Kukes and Kruma, this is a reasonable and competitive price for dried goat meat.

4.3.2 Retailer of Interest and Potential Distribution Network

The HGA Chairman noted that farmers are interested in selling to restaurants. His perspective on selling begins with an initial target market in Kukes and eventually selling to restaurants in Krume that already use traditional products. Selling to traditional markets was also mentioned in conversations at the Faculty of Economics at University of Tirana. Mrizi i Zanave, a restaurant in Lezha, and Kompleksi Rada, a restaurant in Durrës, were mentioned as potential restaurants that may be interested in buying a traditional products. While selling to restaurants is of interest to farmers, there currently are not any established relationships with traders or distribution networks to do so.

The current state of dried goat meat distribution is limited to localized consumption in the home, families, and friends as seen with the dotted lines in Figure 27. Discussions with the chairman and secretary of the HGA revealed that key stakeholders such as the chairman have a tentative plan for a distribution network also seen in Figure 27. The team compared the distribution plan laid out by the HGA Chairman to an FAO case study regarding the distribution of Chivito Criollo del Norte Nequino, a fresh goat meat product in northern Argentina. This successful distribution network in Argentina is outlined in Figure 28. The guide on promoting quality and geographically linked products provided a plan for fresh meat and guide as to

what would fit inside the desired GI mark. The team compared the farmer provided model and suggested certain additions to the model to better understand the product and potential paths to market. This documents the current situation and ideas for improvement. The additions can also be seen in yellow in Figure 27.

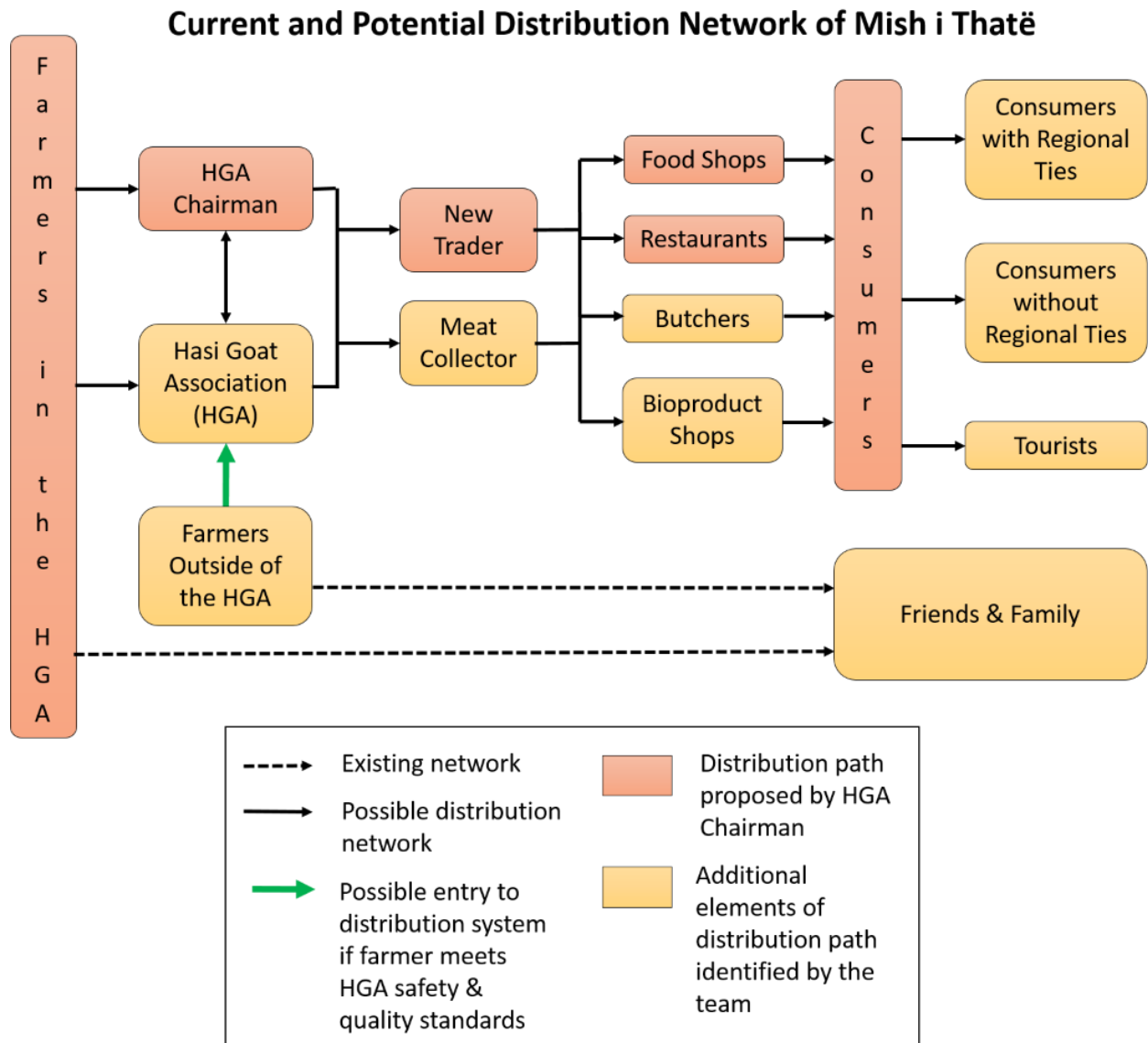

Figure 27: Distribution model comprised of current, proposed, and recommended paths to market.

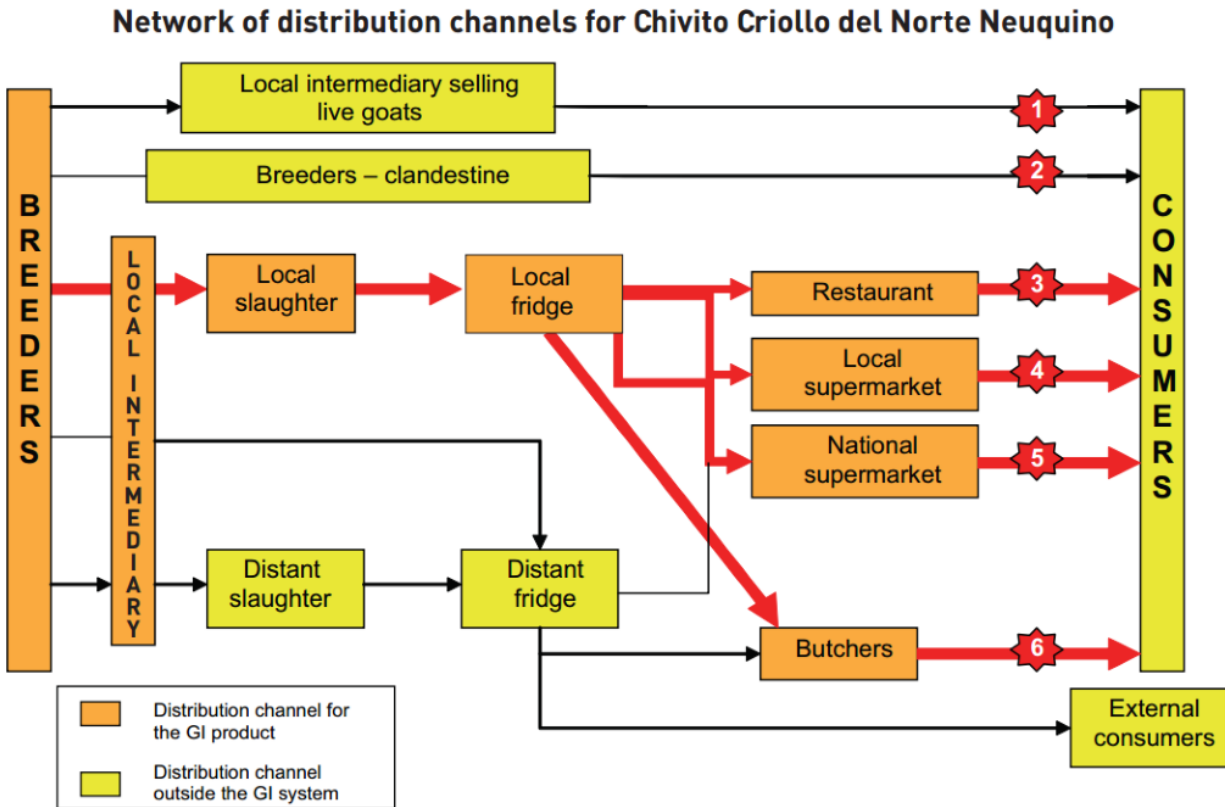

Figure 28: Distribution model of GI marked goat kid meat in Argentina (Vandecandelaere et al., 2010).

4.4 Potential Income

Seventeen HGA member farms reported on the numbers usual of goats each farmer owned, sold, and slaughtered, most of these farms had over 100 goats and all participated in husbandry as their primary economic activity. The data allowed for the team to estimate average amounts of dried meat production and compare them to the price farmers typically receive for live goats (average of 15,000 L regardless of age). On average, farmers gift 16% of the dried meat they produce, however the actual amount ranged greatly from farm to farm. At the end of the year, most farmers slaughtered 5% of their flock as older goats for dried meat production. Once females stop producing milk and once the males become too old, they are sold or slaughtered. On average 8-15% of the entire flock each year are old goats who are often sold live for the consumer to produce their own dried meat. Rather than selling the old goats live, farmers could produce more Hasi "Mish i Thatë" and possibly sell the product at a much higher price.

In addition to information on how many goats were sold and slaughtered, farmers provided an estimate of how much dried meat they produce. The average farmer claimed to produce 49 kg of dried meat a year. After drying, old goats on average yield 12 kg of dried meat per head. If 5% of the average flock of 41 goats is translated to dried meat then the number of old goats slaughtered can be used to calculate the

approximate amount of dried meat each farmer should have produced. By comparing each farmers' reported dried meat production to old goats slaughtered the team noticed a deficit of about 17%.

The team believes the mismatch in these estimates is due to limited record keeping and a lack of measurement. The deviation in production differences was large and the 12kg average yield is an estimate, which accounts for some error. However the difference indicates there is room for improvement. Another source of error could be that farmers may eat some of the old goat meat fresh rather than drying it, which would yield less dried meat than the estimate.

4.5 Insights on Promoting a Niche Product

To better understand marketing trends in Albania, Professor Dr. Ilija Kristo's Masters class from the Faculty of Economics at the University of Albania was consulted; complete notes from the focus group can be found in Appendix F: Marketing Focus Group Notes. There were many useful insights to the opinions Albanian consumers have on bio-based products. Within Albania many people care about the region and story behind products they are buying. When asked about local, mountain based products the group agreed that local products from mountain regions were the most desirable. These reactions support initial claims of consumer preferences based off of Imamia's research on Consumer Preferences for Lamb Meat in Central and Southwest Urban Albania.

While local, mountain products were clearly valued, none of the class had heard of Geographic Indicator (GI) Marks. Since GI marks are being pursued by the RASP, the Albanian population will need to be educated on what the mark means on packaging, or the product should be marketed to those who are knowledgeable and appreciate its value. While GI Marks demonstrate a products origin and act as a specific mark of quality, without explicit explanation on the packaging a consumer may be unaware the dried meat was produced locally under certain standards.

Consumer preferences appear consistent throughout different age groups, based on the limited experiences of mountain farmers and the focus group of students finishing their MBA's at the University of Tirana. The MBA students drew attention to different age groups and their exposure to different methods of advertising. The focus group indicated that promotion through social media and websites is more effective for younger people while television advertisements are more effective for those who are older. This knowledge regarding demographic marketing mediums is important but is less useful without understanding the target market. Target markets have diverse means of seeing advertisements; a consumer interest survey may be beneficial in developing the most effective promotion plan. Tailoring a

promotion plan based off of the most interested consumer group would allow for a more accurate investment of capital when developing the Hasi goat brand.

4.6 Creating a Development Plan for the Hasi Goat Brand

To best promote the Hasi Goat brand, four key strategies to fulfill the project's third objective have been identified:

1. Improve technical aspects to increase standardization and quality control.
2. Build capacity of farmers to improve the drying process and safety.
3. Develop a promotional campaign.
4. Establish a business plan.

Using the results of SWOT analysis, the team identified factors in four main categories as seen in **Error! eference source not found..** Prioritizing the crucial elements of the analysis led to the development of a strategy matrix seen in Table 2.

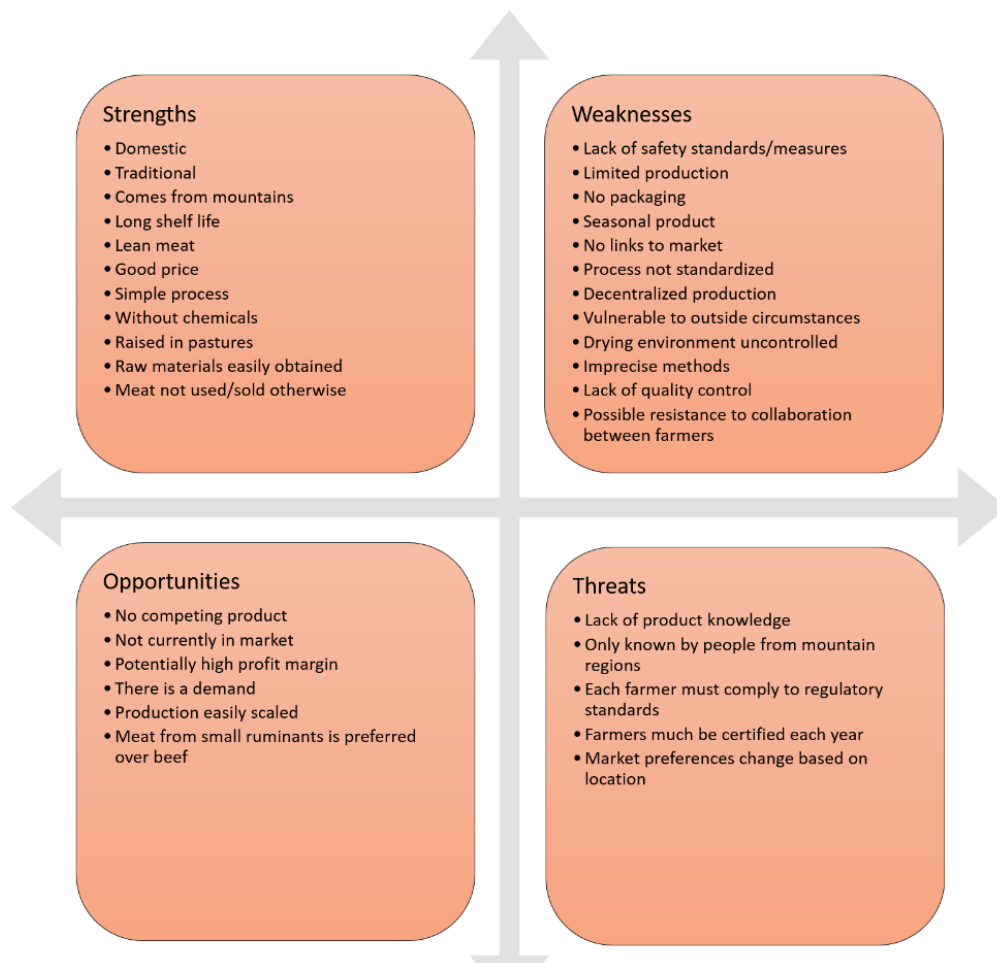

Figure 29: SWOT Analysis

Strategies one and two relate to the initial goals of the project discussed in sections 4.1 and 4.2, further demonstrating their importance in overall success. This initial focus on improving technical aspects and increasing standardization of the drying process builds capacity for the brand and facilitates the ability of the product to receive the quality mark from the HGA. Development of quality to meet standards of the mark should occur in parallel with brand development. Incorporating the quality mark creates more effective labeling and packaging, leading into the brand’s overall promotional campaign. After increasing the product’s quality and developing key factors of brand promotion a business plan should be established so that clear steps leading to the commercial market can be taken.

Table 5: SWOT Strategy Matrix

Strategies	<u>Opportunities:</u> Market potential Available donor support Small scale investor interest	<u>Threats:</u> Niche market Certification
<u>Strengths</u> Simple process Traditional Reputation of mountain area	<ul style="list-style-type: none"> • Develop promotion campaign • Sensitize donors for feasibility/support • Support small investors to propose business plan 	<ul style="list-style-type: none"> • Develop promotion campaign • Capacity building of farms to improve the process and safety
<u>Weakness</u> Lack of distribution No standards Lack of packaging	<ul style="list-style-type: none"> • Improve packaging and labeling • Establish and support value chain • Implement standards of production, health, safety - quality control traceability 	<ul style="list-style-type: none"> • Implement Technical aspects for standardization of product and respect certification criteria • Development of a quality mark-enlarge market • Diversify packaging according to market variation

5. Conclusions

In the Has Region the method of drying goat meat to produce Hasi "Mish i Thatë" can be classified as a traditional process since farmers throughout the region follow the same practices. While these methods are sufficient thus far, to increase potential success, various improvements to the process are suggested. Farmers are already in agreement upon a selling price and initial retailers of the dried meat, so once the proper quality guidelines are in place and a code of practice is established, the promotion and development of a business plan will help Hasi "Mish i Thatë" successfully reach the market.

5.1 Tradition is Consistent

Traditional methods of slaughtering, butchering, and drying are largely uniform from amongst villages in Has. After the goat has been slaughtered and butchered, the key steps in producing Hasi "Mish i Thatë" are salting for 3-5 days, hang drying for 2-5 days, flipping slices, and then hang drying for an additional 2-5 days. A summary of variations, current safety measures, and initial areas of improvement for this process can be seen in Table 6. The relative consistency in tradition will make pursuing a GI mark such as PDO easier for HGA and RASP, but will ultimately help HGA develop both branding and a high quality product.

Table 6: Variations, current safety measures and key improvements are simplified.

	Minor Variations	Current Safety Measures	Areas of Improvement
Slaughtering	Hanging time	Frequent washing	Post mortem inspections Less porous surfaces Allow rigor mortis to release
Butchering	Nothing of note	Meat does not touch the ground No punctured internals Frequent washing	
Drying	Amount of salt used	Hung indoors Windows are screened Done in winter to reduce microorganism growth	Increased separation between slices Covering to protect meat when drying Experiment with salt levels and spices

5.2 Potential Impact of Measurements and Additives

The compounding factors of estimated production numbers and lack of empirical measurement in seemingly all aspects of the process indicated an area with significant room for improvement. While the team acknowledges that production would vary from year to year depending on circumstances, the lack of record keeping on the subject is a hindrance to developing an effective business plan and attracting

outside investment. The lack of measurement within production indicated that quality control and traceability were done with heuristic methods and therefore subject to larger amounts of error and higher differentiation in production. Due to the importance of quality control, traceability, and accurate production numbers, improvements to these aspects would be highly desirable.

Literature and demonstrated interest suggest that farmers should explore additives as an opportunity for market growth. The farmers and RASP felt that this would be beneficial to reach unaware urban markets not as strongly tied to the region. Additives such as Paprika, Winter Savory, or some of the locally grown herbs could be used to add flavor, and in some cases, improve the safety and shelf life of the final product.

5.3 Selling Dried Meat

Farmers expressed interest in selling Hasi "Mish i Thatë", especially if it were shown that the market was available. Farmers are interested in selling outside the Has region where people do not have means of producing their own dried meat. Traditional restaurants in Lezha and Durres have been discussed as potential starting points to introduce Hasi "Mish i Thatë" to the market. While it is an interest, relationships, and networks with traders or distribution networks for commercial sales have not yet been established. Farmers were willing to sell individually or together, depending on what would give the best price. Based on the live weights of goats and cost of production of Hasi "Mish i Thatë", farmers would need a minimum price of 1000-1360 L/kg for dried meat, though they would prefer to receive 2000-3000 L/kg to ensure a profit. This is a reasonable and competitive price since dried beef at restaurants in Kruma and Kukes sell for 4,000-4,500 L/kg.

A distribution plan plays a key role in the sale of a product and will be instrumental in the success of Hasi "Mish i Thatë". The team acknowledges that all aspects of the distribution model might not be possible and the other actors should be more clearly identified to ensure quality control. Development of the model places the farmers in a much stronger position to understand their product, how to sell it, and provides a foundation for their business development. However, the recommended model incorporates dried meat and helps the farmers identify actors interested in dried meat and potentially fresh meat. The meat collectors, processing, and aspects of traceability for fresh meat should additionally be explored as part of the feasibility study for the HGA business plans.

5.3.1 Packaging Dried Meat

The farmers currently simply store the dried meat in canvas bags around the house. The sale of Hasi "Mish i Thatë" will require a recognized packaging measure. RASP has selected a material for vacuum packaging

which they believe will work well. To support the development of Hasi "Mish I Thatë," the team compared the proposed packaging material to literature on the subject.

Table 7: The materials and properties of a plastic film RASP plans to use in packaging dried meat.

Specifications of Stretch Film	
Material	PE, PA, PP, EVOH, PVDC etc.
Structure	PA/PE 7-layer PA/PP 7-layer PA/PE 9-layer PA/PP 9-layer etc.
Processing technic	multiple co-extrusion
Hardness	Soft
Transparency	transparent
Layer	5-layer ~ 9-layer
Width	120mm ~ 650mm
Thickness	0.03mm ~ 0.5mm
Capacity	300 tons/month
MOQ	500KG
Payment terms	T/T, Western Union, Paypal
Lead time	3~5 days
Shipping way	By Sea, By Air, By Courier
Port	FOB Shanghai, or named port

Barriers against oxygen and water vapor are the most important factors of a packaging material. The material RASP intends to use for packaging is a multilayer film made from polyethylene (PE), polyamide (PA), polypropylene (PP), polyvinylidenechloride (PVDC), and ethylenvinyl alcohol (EVOH). Each of these plastics has different permeabilities to water and oxygen. PE and PP are relatively permeable to oxygen and impermeable to water vapor, PA is relatively impermeable to oxygen and permeable to water vapor, and EVOH and PVDC are additives that provide an additional barrier. According to the FAO, multilayer films provide a stronger protective barrier; PA/PE films are especially effective in protective packaging. By placing PA on the outside layer oxygen is blocked and PE on the inside then blocks the water vapor, since the proposed packaging material is a multilayer system including a PA/PE film it is an effective material in accordance with FAO standards. While there are many sealing methods that can be used with multilayer films, vacuum packaging is one of the best since it completely removes all oxygen. Since the film used is transparent, a product packaged this way would only be susceptible to oxidation, color changes, and rancidity due to light exposure. However, products in dim to moderate lighting environments are not at

high risk for light damage, so for the packaging of Hasi "Mish i Thatë" vacuum packaging remains sufficient. Should light damage become a concern, the vacuum packages can be covered in foil or another opaque film.

5.4 Potential Profits of Hasi "Mish i Thatë"

From the data gathered, an estimate can be made of how much dried meat can be produced throughout the entire Has region. From correlations between size of flock and number of old goats slaughtered and sold, it can be determined that of the 6000 Hasi goats in Has, 11.8% of those goats are old ones that are either slaughtered or sold at the end of the season. That means that there are approximately 70 goats that are either sold or slaughtered for familial consumption. If each goat can be sold for 15,000 L, that is 10,640,000 L worth of goats. If those goats were dried and sold as Hasi "Mish i Thatë" at a competitive rate of 3000 L/kg, they would be worth 25,535,000 L. That is an additional profit 14,895,000 L. Each goat would be worth 21,000 L more as Hasi "Mish i Thatë". A summary of these findings is outlined in Table 8.

Table 8: Profits of dried goat meat

Profits of Hasi "Mish i Thatë" (ALL)	
Old Goats as Percent of Flock	
Average:	11.8
Standard Deviation:	3.8
Total Hasi Goats in Has	6,000
Total Old Goats in Has Yearly	709
Low Estimate	479
High Estimate	939
Current worth of Old Goats in Has	10,640,000
Potential Worth of Old Goats as Mish i Thatë	
3000Lek/kg	25,535,000
Potential Net Profit of all Old Goats	14,895,000
Potential Net Profit Per Goat	21,000
Average Potential Profit per Farmer	83,680

Spread out over the 178 farms in Has, each farmer would make an average of 83,680 L more than they currently do each year. Some farms would make more and some would make less, depending on the size of the farm. Many of the farms in the HGA have over 100 goats, and so some would increase their profit by over three times the average. All these calculations are done with a price of 3000 L/kg in mind. Dried beef in the area sells for 4500 L/kg, and people tend to prefer goat over beef. A price of 3000 L/kg would be reasonable and competitive with other products in the area.

Table 9: Average yearly potential profit

Profits of Hasi "Mish i Thatë" for Farms Interviewed with Goat Husbandry as Primary Activity (Lek)	
Average Flock Size	116
Average Old Goats per Farm	14
Potential Profit per Goats as Hasi "Mish i Thatë"	21,000
Average Potential Profit of Large Goat Farm	288,400

A subset of farmers who consider themselves primarily goat farmers would profit a greater amount from selling Hasi "Mish i Thatë". Table 9 shows how this income would impact the group of 26 farms interviewed in previous years who have an average of 116 goats per farm. These farms have more old goats each year than the average farm in Has. At an average of 14 old goats per year, farmers in this group would each make a profit of 288,400 in addition to the current price they are selling goats at.

5.5 Promotion Plan for Hasi Goat Breed

Four key strategies to promote the Hasi goat breed were developed using a SWOT analysis. These are:

1. Improve technical aspects to increase standardization and quality control.
2. Build capacity of farmers to improve the drying process and safety.
3. Develop a promotional campaign.
4. Establish a business plan.

Improving technical aspects and increasing quality of Hasi "Mish i Thatë" will assist in developing the brand since improved safety will result in quality marks from the Hasi Goat Association. Including a quality mark on packaging will lead consumers to recognize the high quality of the Hasi goat meat, beginning the promotion necessary for furthering the brand as a whole. Once quality of the product has been increased and brand development has occurred, a business plan should be created to bring the product to markets. The business and promotion plan are heavily dependent upon the target audience, although the consumer preferences remain constant. Once the most profitable consumer group is identified, the promotion plan will be tailored to its interests and advertising means.

6. Recommendations

In this section recommendations based on the SWOT analysis as well as the findings of the project are given. They are organized by objective in the following manner:

1. Recommendations for improving food safety and traceability
2. Recommendations for improving food quality
3. Recommendations for development of the Hasi goat brand and Hasi "Mish i Thatë"

6.1 Improving Product Safety and Traceability

The following recommendations cover product safety and traceability, both important to commercial products and doubly so for new products and those pursuing a GI mark. FAO provides excellent guidelines to follow these procedures and should be used to help RASP using farmer input create safety trainings that produce the desired code of practice and measures to increase product safety.

Properly document animal health care - Obtaining full bills of health from local veterinarians would create accountability in the production cycle. Despite what appears to be expert handling of their flocks a GI product must adhere to strict methods of traceability and documentation of animal health care is recommended by the FAO guidelines, industry guidelines, and GI practices. The nature of marks like PDO (an end goal for RASP with this projet) require the product be accounted for through the entire production process. Health records will also indicate which animals should be used for consumption and which for breeding.

Conduct ante-mortem and post-mortem inspections - Inspections, both before and after slaughter, would help to ensure that the animal is safe for human consumption. FAO and industry guidelines require such inspections as a part of food production. Ante-mortem inspections would look at the medical history of the animal as well as a physical examination of the animal to notice any peculiarities. A post-mortem inspection should look at organs and internal tissues to notice any unusual characteristics such as hardness, size, or presence of lesions. RASP and HGA should use FAO guidelines as they document how to follow the international standard: Codex Alimentarius, Harmonization of Food Standards.

Document sales of animals and animal products - Properly documenting with bills of sale for each animal creates a trail of accountability from producer to consumer. Improved methods of traceability such as these are required for a GI mark and while it may add difficulty improve the quality of the average product. This would ensure value chain actors at all levels to play a role in HACCP, an important part of safe food production that Albanian law is moving towards.

Separate drying area from living quarters and the elements- The current system of hanging and drying meat in well-traveled spaces increases the likelihood that contaminants are introduced. Creating a separate secure area independent of living space, if only during the drying season, would decrease the risk product contamination. Additionally, meat should be covered to avoid interactions with insects, dust, and other naturally occurring contaminants.

Establish markers of health - Creating a set register of simple health checks and sanitation policies that a farmer can quickly and easily follow with minimum equipment will help remove the most preventable maladies. A laminated copy of a list of simple checks such as "Animal is clean, not covered in mud or feces" and "Tools are clean and have been washed recently" could be provided to farmers to hang where slaughter occurs to be a simple reminder of safe operating procedures. Such a checklist should be created through HGA's code of practice for "Hasi Mish i Thatë," developed with farmer input, and taughts as a part of RASP's trainings with farmers.

Create a code of sanitation - A unified list of standards followed for slaughtering and butchering would better secure food safety as well as adding uniformity between different farmers. This set of standards should include specific measures for reducing cross contamination from other goats, reducing exposure to environmental factors as well as identifying and reducing specific hazards such as bone fragments created from butchering.

6.2 Improving Product Quality

While the current product is safe for familial consumption, the team believes that certain improvements could create a more desirable product in general. Other improvements such as spices and other additives should be used to explore new markets.

Experiment with different flavorings - An opportunity for change is the addition of flavorings to attract different types of consumers. Several herbs and spices have been noted for use in this application, including paprika, oregano, and winter savory, which would change the taste of the product while keeping the traditions of the process the same.

Experiment with different sizes of meat, fat content, and salting and drying times - A number of aesthetic features of the product could be majorly changed. The best composition of size, fat, salt, and length of time drying can be determined by trial and error based on farmer preference and strictness to tradition. Different thicknesses of meat will dry at different rates and can become easier or harder to eat based on size and toughness. Increased fat content can make meat more tender and flavorful but can cause the

meat to more easily spoil. Salt concentration should marginally increase because present levels of salt are too low to properly dehydrate and preserve the product. Levels of at least 0.1:1 of salt to meat by weight are recommended. Drying times should also be experimented with in order to properly refine the safest length of time that delivers the best quality product.

Experiment with length of hanging time - Allowing the meat to rest for 24 hours at roughly 40 degrees Fahrenheit would allow rigor mortis to set in and then dissipate leaving the meat more tender. It is recommended that this practice occurs as long as consumers do not consider this change a serious departure from tradition.

Conduct a consumer preference test - The most important recommendation is to expose the product to markets that producers are interested in selling to and collect information on the reaction to the product itself. It is recommended that a taste test is conducted among consumers in the target market to determine what aspects people are interested in, focusing on flavor, texture, and toughness to better tailor the product to those preferences.

Improving measurement - The team felt the lack of empirical measurements throughout the process and in production numbers would hinder development and progress towards the both GI mark and profitable business. Since both the HGA and RASP have indicated an interest in building capacity and larger ROI, empirical measurements are highly desirable. The team believes that despite a homogeneous set of rather objective heuristics in the regional process, that small resources for empirical measurements such as simple multiple use thermometers and scales would greatly contribute to evidence of the farmers' quality control. More accurate production numbers, and demonstrations of quality control and traceability would greatly improve the view of outside investors and potential actors in the supply chain.

- Spring scales* – measuring carcass weight, meat to be dried, fresh meat, and dried meat product
- Electronic thermometers*- measuring both air, room and meat temperature
- Bacterial count*- testing tools and training
- Others include:
- Hygrometer - for measuring relative humidity in drying area
- A_w Meter- measures water activity to determine safe water content
- Compare this to drying standards for handbook

While all of the above tools are useful for improving and controlling the quality of dried meat production, certain aspects (denoted with *) would also be useful in the production of fresh meat. Using these tools with a lower risk product such as dried meat provides an excellent opportunity for the farmers to familiarize themselves with the tools, their care and correct application. The microorganism testing is a slightly more complex operation and a few farmers could receive specialized training on the subject, or the HGA could create a position with a small financial incentive to ensure

6.3 Development of the Hasi Goat Brand and Hasi "Mish i Thatë"

Conduct a market survey to identify target market - A full scale market survey should be conducted in interested markets to best identify the consumers most likely to be interested in the product. This survey will break down consumers by reasons for interest and disinterested in the product. From this a consumer group can be targeted based on the most promising demographics. This research is needed to best market the product and receive the best return for farmers.

Use HGA logo as a quality mark - One note made was that more could be done to tie the product to the region. Using the Hasi Goat Association logo as a quality mark will help establish a brand for all Hasi Goat products. Any future products would use the mark, backed by the trust accumulated from the use with Hasi "Mish i Thatë".

Develop consistent branding using a constant theme with minor changes for various products - Using similar yet slightly different packaging for each different product helps create unity among products while also distinguishing them from each other. This technique has been used in numerous brands, especially those in the food industry, such as Lays, Gatorade, and Jack Links.

Create a brochure for recipes including Hasi "Mish i Thatë" - One easy way to promote the product is to create a booklet of local products that includes recipes containing Hasi "Mish i Thatë". This is a simple way to generate interest and awareness in the product.

Devise methods for smaller producers to sell Hasi "Mish i Thatë" – Involving smaller producers would allow for an increase in the available production of Hasi "Mish i Thatë". Those farmers with a smaller flock are more numerous and enabling them to join the efforts of the HGA would create a greater reach for the product, thus increasing the brand recognition of the HGA and the Hasi Goat in general.

Create an online store and online advertising presence – The internet is a fast and straightforward way to reach a consumer base. An online store advertising to those who are within the discovered consumer segment could allow the farmers to increase their reach and find new markets.

Works Cited

- Albania Program Snapshot*. (2015). Retrieved from <https://www.worldbank.org/content/dam/Worldbank/document/eca/Albania-Snapshot.pdf>
- Byrne, D. V., Waehrens, S. S., & O'Sullivan, M. G. (2013). Future development, innovation and promotion of European unique food: An interdisciplinary research framework perspective. *Journal of the Science of Food and Agriculture*, 93(14), 3414-3419. doi:10.1002/jsfa.6355
- Cherroud, S., Cachaldora, A., Fonseca, S., Laglaoui, A., Carballo, J., & Franco, I. (2014). Microbiological and physicochemical characterization of dry-cured Halal goat meat. Effect of salting time and addition of olive oil and paprika covering. *Meat Science*, 98(2), 129-134.
doi:<http://dx.doi.org/10.1016/j.meatsci.2014.05.018>
- Costa, R. G., de Medeiros, G. R., Duarte, T. F., Pedrosa, N. A., Voltolini, T. V., & Madruga, M. S. (2011). Salted goat and lamb meat: Typical regional product of the city of Petrolina, state of Pernambuco. *Small Ruminant Research*, 98(1-3), 51-54.
doi:<http://dx.doi.org/10.1016/j.smallrumres.2011.03.017>
- Dobi, P. (2015) *Interview with Sponsor/Interviewer: D. Bloemker, S. Mayer, H. Selmer, & S. Cazier*.
- Dobi, P., Hoda, A., & Labinoti, S. (2011). Techno-economic aspects of development for local goat breed farms. *Macedonian Journal of Animal Science*, 1(1), 255-260.
- FAO, Manual on simple methods of meat preservation. Rome: FOOD AND AGRICULTURE ORGANIZATION OF THE UNITED NATIONS
- Flick, U., Metzler, K., Scott, W., & Gale Virtual Reference, L. (2014). *The SAGE handbook of qualitative data analysis*. London, [England]: SAGE.
- Garnier, A. (2015). *Pratiques d'élevage et diversité paysagère dans le Has albanais*. (Master of Science), Institut Agronomique Méditerranéen de Montpellier. (2015-144)
- Germain, C. (2003). *Traceability implementation in developing countries, its possibilities and its constraints: A few case studies*.
- Gjergji, F. (2014). *Migration in Albania*. Retrieved from Tirana, Albania:
- Hajdukiewicz, A. (2014). European Union agri-food quality schemes for the protection and promotion of geographical indications and traditional specialities: an economic perspective. *Folia Horticulturae*, 26(1), 3-17. doi:10.2478/fhort-2014-0001
- Heinz, G., & Hautzinger, P. (2007). MEAT PROCESSING TECHNOLOGY FOR SMALL-TO MEDIUM-SCALE PRODUCERS Bangkok: FOOD AND AGRICULTURE ORGANIZATION OF THE UNITED NATIONS REGIONAL OFFICE FOR ASIA AND THE PACIFIC.

Lloha, I. (2015, November 6, 2015).

RASP. (2014). *Action Plan - For implementation of Hasi goat meat Quality Label in the framework of the Biodic Balkans project conservation and valorization of biodiversity for sustainable rural development in Balkan mountain*. Retrieved from

Santchurn, S. J., Arnaud, E., Zakhia-Rozis, N., & Collignan, A. (2012). *Drying Handbook of Meat and Meat Processing, Second Edition* (pp. 505-522): CRC Press.

Toften, K., & Hammervoll, T. Niche Firms and Partnerships in International Food Supply Chains. *Journal of Food Products Marketing*. Retrieved from http://au4sb9ax7m.search.serialssolutions.com/?ctx_ver=Z39.88-2004&ctx_enc=info%3Aofi%2Fenc%3AUTF-8&rft_id=info:sid/summon.serialssolutions.com&rft_val_fmt=info:ofi/fmt:kev:mtx:journal&rft.genre=article&rft.atitle=Niche+Firms+and+Partnerships+in+International+Food+Supply+Chains&rft.jtitle=Journal+of+Food+Products+Marketing&rft.au=Toften%2C+Kjell&rft.au=Hammervoll%2C+Trond&rft.date=2014-01-01&rft.issn=1045-4446&rft.eissn=1540-4102&rft.volume=20&rft.issue=1&rft.spage=36&rft.epage=54&rft_id=info:doi/10.1080%2F10454446.2013.798752&rft.externalDBID=n%2Fa&rft.externalDocID=372034106¶mdict=en-US

Vandecandelaere, E., Arfini, F., Belletti, G., & Marescotti, A. (2010). *Linking people, places and products. A guide for promoting quality linked to geographical origin and sustainable Geographical Indications*. Rome: United Nations (FAO) and SINER-GI.

Youling, L. X. (2012). Nonmeat Ingredients and Additives *Handbook of Meat and Meat Processing, Second Edition* (pp. 573-588): CRC Press.

References

- Agency, A. I. D. (2009). Development of the Halal Meat Supply Chain In Albania (for Sheep and Goat Meat).
- Anderson, K., & Swinnen, J. (2008). *Distortions to Agricultural Incentives in Europe's Transition Economies*.
- Bernués, A., Olaizola, A., & Corcoran, K. (2003). Labelling information demanded by European consumers and relationships with purchasing motives, quality and safety of meat. *Meat Science*, 65(3), 1095-1106. doi:http://dx.doi.org/10.1016/S0309-1740(02)00327-3
- Chan-Halbrendt, C. (2013). *Agricultural markets in a transitioning economy: an Albanian case study*. Cambridge, MA: CABI.
- Costa, R. G., de Medeiros, G. R., Duarte, T. F., Pedrosa, N. A., Voltolini, T. V., & Madruga, M. S. (2011). Salted goat and lamb meat: Typical regional product of the city of Petrolina, state of Pernambuco. *Small Ruminant Research*, 98(1–3), 51-54. doi:http://dx.doi.org/10.1016/j.smallrumres.2011.03.017
- Dobi, P. Developing high quality meat and cheese goat production in the highlands of Hasi district, Kukes region in North Eastern Albania. Retrieved from https://www.feedingknowledge.net/02-search/-/bsd/5515/en_GB
- Dobi, P., Hoda, A., & Labinoti, S. (2011). Techno-economic aspects of development for local goat breed farms. *Macedonian Journal of Animal Science*, 1(1), 255-260.
- Dobi, P. (2015) *Interview with Sponsor/Interviewer: D. Bloemker, S. Mayer, H. Selmer, & S. Cazier*.
- (FAO), F. a. A. O. o. t. U. N. (1990). Manual on simple methods of meat preservation. Rome: FOOD AND AGRICULTURE ORGANIZATION OF THE UNITED NATIONS
- Germain, C. (2003). *Traceability implementation in developing countries, its possibilities and its constraints: A few case studies*.
- Gjergji, F. (2014). *Migration in Albania*. Retrieved from Tirana, Albania:
- Germain, C. (2003). *Traceability implementation in developing countries, its possibilities and its constraints: A few case studies*
- Hajdukiewicz, A. (2014). European Union agri-food quality schemes for the protection and promotion of geographical indications and traditional specialities: an economic perspective. *Folia Horticulturae*, 26(1), 3-17. doi:10.2478/fhort-2014-0001
- Heinz, G., & Hautzinger, P. (2007). MEAT PROCESSING TECHNOLOGY FOR SMALL-TO MEDIUM-SCALE PRODUCERS Bangkok: FOOD AND AGRICULTURE ORGANIZATION OF THE UNITED

NATIONS REGIONAL OFFICE FOR ASIA AND THE PACIFIC.

IFAD. (2014). Geography, Agriculture, and the Economy. *Rural Poverty Portal - Albania*. Retrieved from <http://www.ruralpovertyportal.org/country/geography/tags/albania>

Kume, K., Bicoku, Y., & Papa, L. (2002). Sheep and goat production in hill and mountainous regions in Albania: Extension service and government subsidies. *Evolution of sheep and goat production system: Future of extensive system and changes in the society*, 3-6.

Lorenzo, J. M., Fonseca, S., Gómez, M., & Domínguez, R. (2015). Influence of the salting time on physico-chemical parameters, lipolysis and proteolysis of dry-cured foal "cecina". *LWT - Food Science and Technology*, 60(1), 332-338. doi:<http://dx.doi.org/10.1016/j.lwt.2014.07.023>

Mavromati, J., Gjeta, Z., Mavromati, E., Kolaneci, V., & Molla, A. (2011). Production Systems and Economics of sheep Husbandry in southern Albania. *Biotechnology in Animal Husbandry*, 27(3).

Teixeira, A., Pereira, E., & Rodrigues, E. S. (2011). Goat meat quality. Effects of salting, air-drying and ageing processes. *Small Ruminant Research*, 98(1-3), 55-58.
doi:<http://dx.doi.org/10.1016/j.smallrumres.2011.03.018>

(RASP), R. A. S. P. (2013). Home. Retrieved from <http://rasp.org.al/ang/index.html>

Appendix A: Initial Interview Questions

Questionnaire for farmers (Dried meat initiative)

Interviewer name:

Institution:

Country:

Translator name:

Date of interview:...../...../.....

Address of the farm:

Municipality:

Region:

Country:

1. Basic Info

- a. Number of goats:
- b. Any other animals?
- c. Are goats your primary source of income?

2. Raising

- a. What distinguishes the Hasi goat from other breeds?
- b. Does all of the feed come from the Has district?
- c. How does where the goats are fed impact the taste?
- d. Animals water supply:
- e. How is animal's health checked:
 - i. If yes: By who:
How often:
 - ii. If no, why not?
- f. What vaccinations do the goats receive, when?
Vaccination: Time:
Vaccination: Time:

3. Slaughtering

- a. How do you slaughter the goats? Can you walk us through the process?

- b. How many goats do you sell a year, how many do you slaughter?
 Sell: Old goats..... Kids.....
 Slaughter: Old goats..... Kids.....
- c. How do you choose goats to slaughter? (Age, gender, weight?)
- d. Number of goats slaughtered at a time:
- e. Time of year slaughtering begins:
- f. Where are the goats slaughtered:
- g. What tools do you use?
- h. How do you clean/sanitize the area and tools?
- i. Time between slaughtering and butchering:

4. Butchering

- a. Do you clean the carcass? If yes, how? If no, why not?
- b. What cuts of meat do you keep?
- c. What is done with the other parts?
- d. Where is meat stored during butchering?
- e. How are the slices cut?
 Thickness:
 Length:
 Is the fat left on or cut off?
- f. How do you separate the different cuts?
- g. Are different cuts used for different purposes?
- h. Are any cuts better for drying? Which?
- i. How long after butchering do you start drying?

5. Drying

- a. Do you dry meat?
- b. When is the best time to start drying meat?
- c. Is temperature checked as meat dries?
- d. Is there ventilation?
- e. How is the meat hung?
- f. When does drying start?
 How long does it take?
- g. What tools do you use?

- h. How do you dry the meat? Can you explain the process?
- i. Why do you use this method?
- j. What do you add to the meat? Do you salt the meat?
- k. If you use additives, when in the drying process are they added?
- l. How do you know the meat is done drying?
- m. What happens if any meat goes bad?
- n. How do you maintain cleanliness throughout the drying process?
- o. How do you preserve the meat after drying?

6. What's done with product?

- a. What is the final product called?
- b. What is the dried meat used for?
- c. When is the dried meat used? (Seasons, months, etc.)
- d. How much dried meat do you sell?
For how much?
- e. How much is given as a gift?
- f. How do you store the dried meat?
- g. How does it taste?
- h. Describe the texture:
- i. How long does dried meat stay good for?
- j. How do you eat the dried meat?

7. General

- a. What is unique about the overall process?
- b. How did you learn this process?
- c. What do you know about the tradition and history of dried meat in the region?
- d. Tell us a story about dried goat meat.

Appendix B: Updated Interview Questions

Questionnaire for Farmers (Dried Meat Initiative)

Interviewee name:

Institution:

Country:

Translator name:

Date of interview:...../...../.....

Municipality:

Region:

District:

Village:

1. Basic Info: see attached table

2. Raising

- a. What distinguishes the Hasi goat from other breeds?
- b. Does all of the feed come from the Has district?
- c. Animals water supply:
- d. How is the animal's health checked and maintained?

3. Slaughtering

- a. How do you slaughter the goats? Can you walk us through the process?
- b. How do you choose goats to slaughter? (Age, gender, weight?)
- c. Time of year slaughtering begins:
- d. Where are the goats slaughtered:
- e. How do you clean/sanitize the area and tools?
- f. Time between slaughtering and butchering:

4. Butchering

- a. Do you clean the carcass? If yes, how? If no, why not?
- b. How do you use the various parts of the goat?
- c. Do you dry meat? Are any cuts better for drying? Which?

d. How long after butchering do you start drying?

5. Drying

- a. When is the best time to start drying meat?
- b. Can you explain the drying process?
- c. Is there ventilation?
- d. How is the meat hung?
- e. How do you know the meat is done drying?
- f. Why do you use this method?
- g. What do you add to the meat?
- h. What happens if any meat goes bad?
- i. How do you maintain cleanliness throughout the drying process?
- j. How do you store the meat after drying?

6. What's done with product

- a. What do you call the final product?
.....
- b. How is the dried meat used?
- c. Describe the taste:
.....
- d. Describe the texture:
.....
- e. How long does dried meat stay good for?
.....

7. General

- a. What is unique about the overall process?
- b. How did you learn this process?
- c. What do you know about the tradition and history of dried meat in the region?
- d. Tell us a story about dried goat meat.
- e. Would you be interested in selling dried meat outside of the region?
- f. What would make you want to sell dried meat?

Appendix C: Individual Farmer Data Table

Section	Question/Pyetje	Farm 1/Fermë	Farm 2/Fermë	Farm 3/Fermë	Farm 4/Fermë
1	Farmer Name/Emër	Sejdi Jemini	Bajram Seli	Fatush Dina	Kastriot
	Date/Data	11/11/2015	11/11/2015	11/11/2015	11/18/2015
	Are you a part of the Goat Breed Association?/A jeni pjesë e shoqatës?				Yes
	Do you have a position in the Association?/A keni një pozicion ne shoqate?				Chair
	# of Goats/Numri i Dhive	120	150	90	300
	Cows/Lopë	15	5	17	14
	Sheep/Dhen	30	7	50	-
	Other/Tjetër	-	-	-	Bees (7)
	Primary source of income/Burimi kryesor i të ardhurave	Goats and cows same	Goats	-	Goats
	2	Animal Health/Shëndetit të Kafshëve			
By who/Nga kush		Vet	Vet	Vet	Vet
How Often/Sa shpesh		As needed	As need	As needed	As needed
Vaccinations received/Vaksinat marrë					
Name/Emri		Agalaxia	Agalaxia	Agalaxia	Agalaxia
Time/Kohë		October	October	October	April and Nov
Name/Emri		Albendazol	Albendazol	Albendazol	Albendazol
Time/Kohë		Spring	Spring	Spring	When necessary
3	# goats sold yearly/Numri i dhive të shitura në vit				
	Kids/Keca	about 80	70-80	90	200
	Old/Vjetër	10	15-20	15-20	15
	# goats slaughtered yearly/Numri i dhive t therrura ne vit				
	Kids/Keca	15	12-15	15-20	40
	Old/Vjetër	4-5	3-5	5-6	4
	# goats slaughtered at a time/Numri i dhive therur në një kohë	4-5	-	-	4 (all)
	4	Information on Slices to be Dried/Informacion mbi fetat e mishit			
Thickness/Gjerësi		2-3cm (2 finger)	-	-	-
Length/Gjatësi		50cm	-	-	-
Is fat left on or cut off?/Dhjami, lihet apo hiqet		On	-	-	On
6	Dried meat produced/Mish i tharë i prodhuar	70-75 kg	50 kg	100 kg	50 kg
	Dried meat gifted/Mish i tharë i dhuruar	10 kg	5 kg	5-6 kg	5 kg
	Dried meat sold/Mish tharë i shitur	none	none	none	none
	What is the selling price?/Sa kushton (cmimi)?	-	-	-	Kruma Restarant 4000lek/kg

Farm 5/Fermë	Farm 6/Fermë	Farm 7/Fermë	Farm 8/Fermë
Mentor 11/18/2015	Kamber Lleshi 11/18/2015	Bajram Alpapa 11/18/2015	Asyoaf Nega 11/18/2015
Yes	Yes	Yes	Yes
No	No	No	Son on committee
120	110	140	130
10	5	7	4
-	-	-	-
-	1 horse, 1 donkey	2 horses	1 horse
Goats	Goats	Goats	Goats
Vet As needed	Municipal vet As needed	Municipal vet As needed	Municipal vet As needed
Agalaxia April and Nov	Agalaxia Spring & Autumn	Agalaxia Spring & Autumn	Agalaxia Spring & Autumn
Albendazol When necessary	Enteortoxmia Spring & Autumn	Enteortoxmia Spring & Autumn	Enteortoxmia Spring & Autumn
	None this year		
70	too young	100	-
7-8	-	10	-
20	10-12	15	-
2	7-8 (for self)	7	-
2 (all)	Avg. 1/month but most in Nov/Dec	Avg. 1/month but most in Nov/Dec	-
-	2-3 cm	2-3 cm	2-3 cm
-	20-30 cm	20-30 cm	20-30 cm
On	-	-	-
25 kg	30-35 kg/year	100 kg/year	Doesn't know
2 kg	2 kg	3-4 kg (to sister and niece)	-
none	none	none	-
Kukes 4500lek/kg	-	-	-

Appendix D: All Collected Farmer Data

Question/Pyetje	Farm 1/Fermë	Farm 2/Fermë	Farm 3/Fermë	Farm 4/Fermë	Farm 5/Fermë	Farm 6/Fermë	Farm 7/Fermë	Farm 8/Fermë
Farmer Name/Emër	Sejdi Jemini	Bajram Sel	Fatush Dina	Kastriot Dajçi	Mentor Dajçi	Kamber Lleshi	Bajram Alpapa	Isuf Nega
Village Date/Data	Gjinaj 11/11/2015	Gjinaj 11/11/2015	Gjinaj 11/11/2015	Mujaj 11/18/2015	Mujaj 11/18/2015	Kishaj 11/18/2015	Kishaj 11/18/2015	Kishaj 11/18/2015
Are you a part of the Goat Breed Association?/A jeni pjesë e shoqatës?	Yes	Yes	No	Yes	Yes	Yes	Yes	Yes
Do you have a position in the Association?/A keni një pozicion në shoqatë?	No	No	No	Chair	No	No	No	Son on committee
# of Goats/Numri i Dhive	120	150	90	300	120	110	140	130
Cows/Lopë	15	5	17	14	10	5	7	4
Sheep/Dhen	30	7	50	-	-	-	-	-
Other/Tjetër	-	-	-	Bees (7)	-	1 horse, 1 donkey	2 horses	1 horse
Primary source of income/Burimi kryesor i të ardhurave	Goats and cows same	Goats	-	Goats	Goats	Goats	Goats	Goats
Animal Health/Shëndetit të Kafshëve								
By who/Nga kush	Vet	Vet	Vet	Vet	Vet	Municipal vet	Municipal vet	Municipal vet
How Often/Sa shpesh	As needed	As need	As needed	As needed	As needed	As needed	As needed	As needed
Vaccinations received/Vaksinat marrë								
Name/Emri	Agalaxia	Agalaxia	Agalaxia	Agalaxia	Agalaxia	Agalaxia	Agalaxia	Agalaxia
Time/Kohë	October	October	October	April and Nov	April and Nov	Spring & Autumn	Spring & Autumn	Spring & Autumn
Name/Emri	Albendazol	Albendazol	Albendazol	Albendazol	Albendazol	Enteortoxmia	Enteortoxmia	Enteortoxmia
Time/Kohë	Spring	Spring	Spring	When necessary	When necessary	Spring & Autumn	Spring & Autumn	Spring & Autumn
# goats sold yearly/Numri i dhive të shitura në vit						None this year		
Kids/Keca	about 80	70-80	90	200	70	too young	100	-
Old/Vjetër	10	15-20	15-20	15	7-8	-	10	-
# goats slaughtered yearly/Numri i dhive të therrura në vit								
Kids/Keca	15	12-15	15-20	40	20	10-12	15	-
Old/Vjetër	4-5	3-5	5-6	4	2	7-8 (for self)	7	-
# goats slaughtered at a time/Numri i dhive të therrur në një kohë	4-5	-	-	4 (all)	2 (all)	Avg. 1/month but most in Nov/Dec	Avg. 1/month but most in Nov/Dec	-
Information on Slices to be Dried/Informacion mbi fetat e mishit								
Thickness/Gjerësi	2-3cm (2 finger)	-	-	-	-	2-3 cm	2-3 cm	2-3 cm
Length/Gjatësi	50cm	-	-	-	-	20-30 cm	20-30 cm	20-30 cm
Is fat left on or cut off?/Dhjami, lihet apo hiqet	On	-	-	On	On	-	-	-
Dried meat produced/Mishi i tharë i prodhuar	70-75 kg	50 kg	100 kg	50 kg	25 kg	30-35 kg/year	100 kg/year	Doesn't know
Dried meat gifted/Mishi i tharë i dhuruar	10 kg	5 kg	5-6 kg	5 kg	2 kg	2 kg	3-4 kg (to sister and niece)	-
Dried meat sold/Mishi i tharë i shitur	none	none	none	none	none	none	none	-
What is the selling price?/Sa kushton (cmimi)?	-	-	-	Kruma Restarant 4000lek/kg	Kukes 4500lek/kg	-	-	-

Farm 9/Fermë	10	11	12	13	14	15	16	Farm 17/Fermë
Bilbil Thaçi	Bajram SH. Thaçi	Besim Thaçi	Shyqyri Kastrati	Bajram Kastrati	Shefki Kastrati	Man Kastrati	Haxhi Goça	Avdyll Kastrati
Domaj 28/11/2015	Domaj 28/11/2015	Domaj 28/11/2015	Pus I Thate 29/11/2015	Pus I Thate 29/11/2015	Pus I Thate 29/11/2015	Pus I Thate 29/11/2015	Vlahen 3/12/2015	Golaj 3/12/2015
Yes	Yes	Yes	Yes	Yes	Yes	Yes	Yes	Yes
No	No	Member of committee	No	No	vice Chair and privat vet	No	no	no
82	90	105	138	90	40	130	200	135
4	3	4	5	9	2	13	3	4
-	-	-	-	-	-	-	-	-
1 donkey	1 donkey, 1 Horse	1 donkey, 1 Horse	1 donkey, 1 Horse	1 donkey, 3 Horses		2 horse	1 horse	1 horse
Goats	Goats	Goats	Goats	Goats	Goats	Goats	Goats	Goats
Privat Vet and Municipal vet As needed	Privat Vet and Municipal vet As needed	Privat Vet and Municipal vet As needed	Privat Vet and Municipal vet As needed	Privat Vet and Municipal vet As needed	himself As needed	Privat Vet and Municipal vet As needed	Privat Vet and Municipal vet As needed	Privat Vet and Municipal vet As needed
Agalaxia Spring & Autmun	Agalaxia Spring & Autmun	Agalaxia Spring & Autmun	Agalaxia Spring & Autmun	Agalaxia Spring & Autmun	Agalaxia Spring & Autmun	Agalaxia Spring & Autmun	Agalaxia Spring & Autmun	Agalaxia Spring & Autmun
Enteortoxmia Spring & Autmun	Enteortoxmia Spring & Autmun	Enteortoxmia Spring & Autmun	Enteortoxmia Spring & Autmun	Enteortoxmia Spring & Autmun	Enteortoxmia Spring & Autmun	Enteortoxmia Spring & Autmun	Enteortoxmia Spring & Autmun	Enteortoxmia Spring & Autmun
43	50	70	80-90	65	25	70-80	110	50
5_6	5	no - jounq	5	10	-	12	15	8
7	5	5-6	10-15	20-25	5	5-7	15	10
4	5	10	5-6	5	8		5	2
4 (oll)	5	10	5-6	5	8	5-7	5	drurin the year Celebration
2-3 cm 60 - 80 Cm	2-3 cm 60-80 cm	2-3 cm 60-80 cm	2-3 cm 60-80 cm	2-3 cm 60-80 cm	2-3 cm 60-80 cm	2-3 cm 60-80 cm	2-3 cm > 80 cm	2-3 cm > 80 cm
On	on	on	on	on	on	on	on	on
30 - 40 kg/year	40-50 kg	70-80 kg	40-50	35-40	25	80	40	No from goats
7-10	10-15 kg	10-20	5 kg	10	5	5	2	
-	-	-	-	-	-	-	-	-
-	-	-	-	-	-	-	-	-

Appendix E: Meat Expert Interview Notes

3 kinds of drying – based different percent moisture:

1. Drying: 15-17%
 - a. Not technical because there is no control over climate conditions
 - b. In Albania, typically outside
 - c. Must be a naturally warm climate
 - d. Cover meat by plastic (most common) or glass because of microbiological conditions, first drying in sun, leave product for a longer amount of time until 15% moisture is achieved
 - e. Two stages of drying
 - i. Evaporating stage
 - ii. Losing of Energy
 - f. Types of water:
 - i. Strong bond (10%) – lost in stage 2
 - ii. Weak bond (20%) – lost in stage 2
 - iii. Free (70%) – lost in stage 1, cannot lose all of it
 - g. Method used in Albania because it's cheap and easy
 - h. Properties of meat dried this way compared to dehydration: dry, strong surface, darker, thicker, tougher
2. Dehydration: 8-10%
 - a. Must have food technology to control temperature, moisture, etc.
 - b. Hot air drying
 - i. Must be dry air, not steam
 - ii. Air temperature varies for time required
 - iii. 35C but no more than 60C (same limit with meat smoking)
 - c. Benefits:
 - i. Safer
 - ii. Longer shelf life
 - iii. Rehydration is better
 - iv. Surface of meat isn't different from inside – more homogeneous
 - d. Technology isn't too expensive
 - e. Most common worldwide
3. Liofilisation (freeze drying)
 - a. Remove all water inside (possible, usually not all is removed)
 - b. Can't go under a certain water percentage, which varies by food
 - i. Animal products = 2%
 - ii. Any less and the fat begins to oxidize
 - c. Not often prepared this way. Mainly used for milk and eggs.
 - d. Take water out of frozen meat using a vacuum

No one invests in things that people don't like – aka drying technologies because dried meat isn't popular on market.

Salting is more popular in Albania, same results without having to remove water.

Cut of meat doesn't impact anything in drying.

Important factors:

- Must clean meat with either moving fresh water or a salt solution (10-30% NaCl)
- Cover it – not too much contact with air
- Hung 10-15cm apart

On Age of Goats:

- Age is most important in taste
 - Younger = better because of fat
- Chemistry of fats
 - Unsaturated (no H) as animal gets older
 - Creates a double bond
 - Oxidizing is more difficult than smaller change fatty acids
 - Oxidation occurs at weakest points of the bond
 - 2-3 carbons tastes better than a 6-7 carbon chain
 - Shorter is more difficult to cut since the process isn't enzymatic, it relates with oxygen and the oxidation of fats
 - % fat is most important in taste and aroma
 - Fat content does not interfere with storage
- Can't really notice if dried meat is from a young or old goat, there are differences chemically but when dried it's hard to tell
- Older goat meat: darker, thicker muscle fibers (become closer together), tougher, stronger taste
 - Fat and thickness of fiber are the two main differences between young and old goats
- Quote: "We don't eat old goat meat because it is very tough."

2 Kinds of Safeness:

1. Oxidative – after a certain time this cannot be avoided
2. Bacteria – don't use fat, only proteins and sugars are used for energy

Salting & Additives:

- Salt makes meat less tough. However this is a separate process is without putting anything.
- Salt takes water out of fibers and denatures proteins.
- Quantity NaCl for salty meat is 10-30%
- Wet salting is better
 - 10-30% solution in water
 - Leave a certain amount of time: 2days – 1 week
- Must add something (salt) for older goats since salty meat is better to dry
- Can't avoid using salt but flavor can be contrasted by adding sugar
- Quotes:
 - "Salt is only product we can't avoid to put in meat."
 - "Every meat byproduct needs salt...you have to use it."
- Enzymes
 - Aren't really used in drying meat
 - Don't function properly in meat
- Nitrates and Nitrites
 - NO₂ & NO₃
 - Used for color
 - NO₂ – very toxic, but can't avoid for color
- KCl
 - Sometimes used instead of NaCl

- Makes meat taste like metal
- NaCl is better

On Safety, Cleaning, and Asking About Sterilization:

- Cannot directly ask if they sterilize
- Must wash meat surface before drying
 - Salty water is better, don't soak it, just wash it
 - Without washing bacteria will grow on surface
- Wash hands
- Leave distance between pieces
- Must cover meat
- Farmers must not need to input cost. They will not change their way of drying and selling, however making small arrangements is possible.
- Quote: "Drying process is unsafe itself ... to lower risk is only hygiene of places where raising animals, hygiene of room where stored."
- NaCl and NO₂ will kill almost everything
- Look for:
 - Vaccinations
 - Which ones, what times are they given
 - Veterinary stamp
- Have to standardize practice. Must follow same practice in area to get a quality mark.
 - Quote: "All in the same boat to get quality mark. If one does it one way and another on way, nobody gets a quality mark."
 - Slaughter should be during the same period and to the same standards
- Longer drying process is more dangers, slower = worse

Slaughtering:

- After slaughtering must wait 24 hours to eat
- Don't say reason for waiting is to let blood drain. Must wait to follow pre/post mortem things.
- Can't cut into pieces right after slaughter, must hang first so enzymatic reactions can occur.
 - 6-48 hours: based on size of animal
 - Young goat (18kg of meat): 12-24 hours
 - Denaturation of proteins occurs because of changes in pH and muscle begins to relax. Then can cut in slices.
- Hang in room not in contact with outside
 - Temperature: 4-25C
 - Not a fridge
 - Inside with windows closed
- Rigor mortis is very important point of all this. Can't refrigerate after slaughter because rigor amorist will not go away.

Prior Analysis of Goat Meat:

- He made analysis of meat, results were very good
- Expected high fat and low protein
- Results:
 - Moisture in meat: 75%
 - Protein: 20%
 - Fat: 3.1%

- Ash minerals: 1.2%
- Range of protein needed is 15-22% where 22% is high quality meat
- Quote: "It was very good meat, high quality meat."
- Look for nitrogen present when assessing protein
- In dry meat N, fat, and minerals don't change. When rehydrated these things will be the same as it was in fresh meat.
 - Water solution is used to analyze the meat composition. So you can only analyze fresh meat, not the dried meat.
- There are changes in vitamins when the meat dries.
 - Susceptible to outside exposure, they oxidize
 - Lost almost all when drying
 - Lose 50% of fat soluble vitamins
 - A, D, K, E – in fat but at low levels
 - Lost all water soluble vitamins: B & C
 - Don't need vitamins in meat, so this isn't important, eat meat for protein
- Testing was done in younger goats
- Older would have lower protein and higher fat contents
 - Total amount of protein would be the same, but type of protein would be different.
 - Sarcoplasmic & Stromata: myofibril proteins that can be digested. Decrease as animal ages.
 - Ligaments: can't digest, increase in old meat

Appendix F: Marketing Focus Group Notes

University of Tirana Marketing Focus Group

Interviewee name: Professor Dr. Ilia Kristo's Masters Class

Institution: University of Tirana, Faculty of Economics

Country: Albania

Date of interview: 11/12/2015

- Under half of the class had ever tried dried meat
 - Of those who had tried it, one who didn't like it said he thought it was too strong and "heavy in stomach"
- Bioproducts are popular
 - Student recommended looking in the chain Natural for a possible partnership
- Professor Kristo said that he's only seen dried meat for 30-40€ per kg
- TV advertisements would be better for older people since many families watch TV during dinner
- Facebook and websites would be better than TV, especially for young people
- Should identify target market (target based on age was recommended)
 - Older people might be more interested
 - Should sell in cities where dried goat meat isn't produced (Tirana, Durrës)
 - Traditional Restaurants may be good venue for selling dried meat
 - Stores selling cheese and meats products also may be a viable market
- People care about the tradition behind the product
- Products from the mountain region are desirable
- One student recommended not to add spices, people would like it to be plain
- Class didn't know about GI's, but did think that the idea behind the indicator was good
 - Said to explain on packaging if used
- Recommended a consumer interest survey

Appendix G: Hygiene & Safety Criteria

	Hygiene/safety Checks	Notes
Slaughtering	Ante mortem inspection?	Checked once every one or two months
	Postmortem inspection?	Not done
	Are any organs pierced?	No
	Are animals scalded - how is hair removed?	No scalding, all hair is removed through the skinning process.
	Hanging time?	Equivalent to the skinning time of approximately 20 minutes.
	Goat selection	Usually selected by age (7 or 8 years old), never kids or very old goats.
Butchering	Washing of carcass	Not washed but coagulated blood is cleaned off frequently.
	Sanitation of tools	Cleaned with chemical soap and hot water
	Sanitation of workspace	Washed with potable water
	How often are hands washed?	Frequently, between different steps of process as well as intermediately during skinning.
	Are the bones cut clean and without jagged edges?	Yes
	Length and width of stripes cut	50 cm long and 1-5 cm wide
General	Is water used for sanitation potable?	Yes, drinking water source is used for cleaning.
	Is there any record keeping?	Currently little recording, beginning to work on effective record keeping with RASP.
	Frequency of sanitation	Tools and hands washed frequently. Surfaces rinsed at least 4 times throughout process.
	How are waste portions disposed of?	Thrown into a wheelbarrow and then tossed into nature.
	Procedure for separating consumable and non-consumable parts?	Use trays to separate during cutting and butchering.
	Is there adequate lighting?	Yes since done outdoors in natural light.
	How are pests controlled?	No direct methods of control observed.
	Where is human waste disposed of?	Separate from where food is handled.

List of texts used to compile the criteria: *Meat Processing Technology for Small to Medium Scale Producers* by Hautzinger & Heinz, *Good Practices for the Meat Industry* by FAO, and *Handbook of Meat and Meat Processing* by Hui.

Appendix H: Drying Pamphlet Produced for RASP



NATURAL PRODUCT

The high quality of Hasi goat meat can be attributed to the environment of the Has region. High in the mountains they only breathe clean air, drink fresh water, and graze in the Highland pastures.

Hasi goat diet consists only of local grasses, oak leaves, and herbs. The taste of these mountain herbs is even present in the flavor of the dried meat, making the addition of flavors or chemicals unnecessary.

Produced by:
Daniel Bloemker
Scott Cazier
Sienna Mayer
Heather Selmer

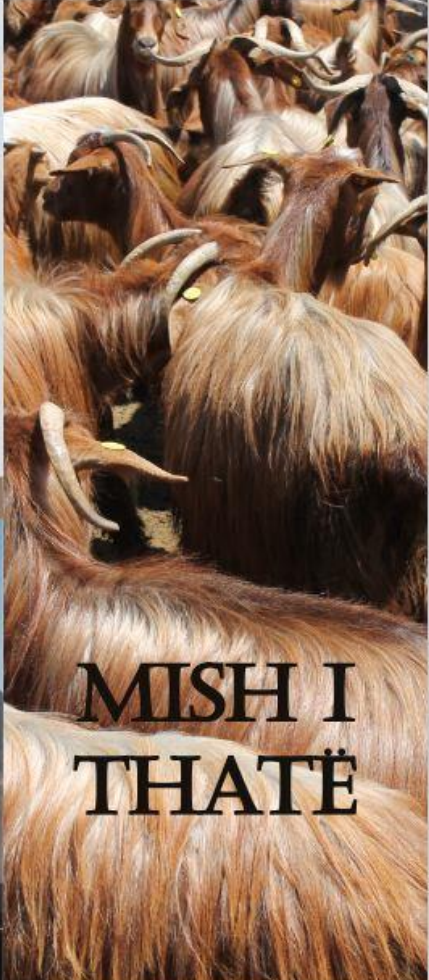
from Worcester Polytechnic Institute
in partnership with



**MISH I
THATÈ**



THE HASI GOAT

This strong, large goat breed is well suited for the mountainous climate and pastures found in the Has region and has been found in the area for hundreds of years. This long history has made the Hasi goat a part of the culture and tradition of the region.

The Hasi goat is known for its high quality of milk and meat. Meat from the Hasi goat is 19.8% protein, 1.2% minerals, and only 3.1% fat - making it a very nutritional, lean meat.

TRADITIONAL PRODUCTION

Farmers begin preserving meat for the winter once the weather becomes cold and dry. Historically the drying process begins in mid-December and this tradition has continued throughout the years. Younger generations learn this drying process through a combination of visual and oral tradition, watching their parents passing down each small detail.



The traditional method of preparation is to cut slices of leg meat, salt them for a few days to add flavor, then hang the slices until they are completely dry. The final product of this process is the traditional product Mish i Thatë.

USES OF MISH I THATE



Mish i Thatë is a staple in the diet of the Has region for the entire winter. It can be eaten plain or, more traditionally, is cooked with rice or beans. Dried meat boiled with white beans is an especially popular winter dish. During the winter as family and friends visit it is common to present the guests with drinks and small packages of dried meat.

