

Project Number: MQF-IQP 4509

**An Interactive Qualifying Project**

submitted to the Faculty

of the

WORCESTER POLYTECHNIC INSTITUTE

in partial fulfillment of the requirements for the

Replacement Hand Washing System

By

Jeremy Brassard

David Markham

Amber Truhanovitch

January 11, 2012

Approved

Prof. M. S. Fofana, Advisor

Mechanical Engineering Department

---

## Abstract

Washing your hands is the most effective and number one way to prevent the spread of germs. Improving hand hygiene is a challenge because even though guidelines are provided society's compliance is substandard. We believe that compliance is inadequate because washing hands often takes time away from the worlds fast pace, busy schedule.

Our design project goal is to design an improved faster way to wash hands. The device needs to be easy for any person to use and comparable to the gold standard, washing hands with soap and water. Ideally this technology will get rid of grime, kill germs, and dry hands all in less than 15 seconds. The optimal design will use minimal energy and filtered water for sustainability, as well as decrease usage costs. Finally the device will have a cost comparable to current public facilities and be safe for all users.

Our solution approach was to design an all in one unit that takes the place of current sinks, soap dispensers, and drying technology. Our unit is designed to fit into the wall and be approximately 35" x 20" x 20" in size. The touch free unit utilized IR sensors and an MCU to control each function of the hand washing process. The user puts their hands inside the opening; soap is sprayed from the wrist to the fingers in 4 seconds; a short pause will allow users to scrub their hands if desired: filtered water will then spray from the wrist to fingers in another 4 seconds. Finally like a hand dryer, right at the opening air is blow out allowing users to pull their hands out dry. The full process is touch free using energy efficient parts to maintain sustainability, save water and completely washes and dries hand in less than 25 seconds.

In conclusion, the team designed a technologically advanced way to wash hands that would be energy efficient, help save water, and allow people to wash hand more often.

# Table of Contents

<i>Abstract</i> .....	<i>i</i>
<i>Table of Contents</i> .....	<i>ii</i>
<i>List of Figures</i> .....	<i>v</i>
<i>List of Tables</i> .....	<i>vi</i>
<i>Acknowledgments</i> .....	<i>vii</i>
Chapter 1 - Purpose.....	1
Introduction .....	1
Chapter 2 – Germs and Sanitation .....	4
2.1 Why Is Hand Washing Important .....	4
2.2 Proper Ways to Wash Hands .....	4
2.3 Germs.....	6
2.3.1 What Are Germs .....	6
2.3.2 Where Are Germs Found.....	8
Hospitals and Nursing Homes.....	9
Within the Community: Schools, Restaurants, Malls .....	9
2.3.3 Spread of Germs .....	10
2.4 The Skin.....	11
2.5 Different Hand Disinfecting Techniques .....	15
2.4.1 Soaps.....	15
2.4.1.1 Everyday soap.....	15
2.4.1.2 Surgical scrubs .....	17
2.4.1.3 Soap for Elderly and Babies.....	21
2.4.1.6 Dirt & Grime Soap.....	23
2.4.2 Comparison of Different Types Soaps.....	24
2.4.3 Hand Sanitizers .....	26
2.4.4 UV sanitation .....	28
2.4.4.1 What is UV light .....	28
2.4.4.2 Danger of UV light .....	29
2.5 Comparison of Soap, Hand Sanitizers, and UV Sanitation.....	29
2.6 Current technology.....	30
2.6.1 Sinks/soap dispensers.....	30
2.6.2 Hand drying methods.....	34

2.6.2 Hand Sanitizer dispensers/ containers.....	40
2.6.3 UV sanitation devises .....	43
2.6.4 Current similar technology/ patents for washing hands.....	43
2.7 Current technology on Filtration systems .....	49
2.7 Sustainability.....	51
Chapter 3 - Designs.....	52
3.1 Problem Statement .....	52
3.2 Design Objectives .....	53
3.3 Design Constraints .....	54
3.4 Objectives & Constraints Tree.....	55
3.5 Design Flow Chart .....	56
3.6 Design Alternatives.....	57
3.6.1 Selection Sanitation Method: Soap, Hand Sanitizer, UV Sanitation .....	57
3.6.2 Alternatives .....	58
3.7 Final Design Components.....	63
3.7.1 Final Solution.....	64
3.7.2 Final Solution System .....	66
3.7.3 Final Water Reserve.....	70
3.7.4 Final Water Filtration.....	74
3.7.5 Final Pump Selection .....	78
3.7.6 Final Sensor Selection.....	84
3.7.7 Final User Interface.....	87
3.7.8 Final Timer Design.....	89
3.7.9 Final Water Sprayer .....	94
3.7.9 Final Water Slider.....	98
3.7.10 Final Blower.....	103
3.7.11 Final Design Put Together .....	108
Chapter 4.....	113
4.1 Financial Break Down.....	113
4.1.1 Bill of Materials Break Down.....	113
4.1.2 Traditional Bathroom Costs .....	114
4.2 Ethical Issues .....	114
4.3 Future Modifications.....	115

4.5 Conclusion.....	116
Works Cited.....	118
Appendix A.....	120

## List of Figures

Figure 1 is a representation of the most frequently missed areas on the hands when washing. (Southeastern District Health Department, [20]).	5
Figure 2 is an electron micrograph of a soil bacterium, <i>Pseudomonas fluorescens</i> . (Rybicki [19]).	7
Figure 3 shows the structure of common illnesses caused by viruses (Rybicki [19]).	8
Figure 4 illustrates the common liquid hand soap, Softsoap gallon-size container.	15
Figure 5 illustrates the chemical property of soap.	16
Figure 6 is a common solid bar soap, Dial antibacterial soap.	16
Figure 7 is the common surgical scrub, Chlorhexidine 2% solutions and 4% solutions.	18
Figure 8 illustrated In vitro germicide effect of six products (four alcohol solutions) for 3 min in a model of infected skin.	20
Figure 9 is from the study of the efficiency of surgical scrubbing up with three products on cutaneous germs.	20
Figure 10 shows <i>bare organics</i> , an organic baby soap with no scent.	22
Figure 11 is a common heavy-duty scrub, Gojo Pumice Hand Cleaner.	24
Figure 12 is a common hand sanitizer, Purell with aloe.	26
Figure 13 is a common bathroom sink (Sinks n.d.).	30
Figure 14 is a Kimberly-Clark soap dispenser (Maddison and Dawson [17]).	32
Figure 15 is surgical hand soap dispenser (Albert and Thomas [2]).	33
Figure 16 shows three different kinds of hot air hand dryers (Dyson [11]).	35
Figure 17 demonstrates motion sensors used on hand dryers (Dispensers [9]).	36
Figure 18 is a representation of the Dyson AirBlade and its interior components (Dyson [11]).	38
Figure 19 is a Purell pump hand sanitizer dispenser (Depot [8]).	41
Figure 20 is a Purell motion sensitive hand sanitizer dispenser (Staples [23]).	42
Figure 21 is a UV-C germicidal wand (Lyon [16]).	43
Figure 22 is an automated sink (Davies [7]).	45
Figure 23 is a full washing drying station (Chardack [5]).	47
Figure 24 is another hand washing station (Stanley E. Flowers [22]).	48
Figure 25 is an automatic sink (Foster [14]).	49
Figure 26 is a typical household water filter layout (Thellmann [24]).	50
Figure 27 is the filtration system for automatic car washes (Ennis & Chelton [12]).	51
Figure 38 is an image of the Pentek U440 FreshPoint Ultrafiltration Whole House Water System (Pentek U440 FreshPoint Ultrafiltration Whole House Water System 2011).	77
Figure 45 is a picture of an MSP430 from Texas Instruments.	90
Figure 46 is a block diagram of the MSP430 from Texas Instruments. The MSP430 and its data sheet can be obtained from the common electrical engineering product website Digi-Key.com.	91
Figure 49 is a SolidWorks model of the spraying mechanism.	97
Figure 54 is an Excel HO-IC hand dryer.	104
Figure 55 is the leading dryer from Excel.	104
Figure 56 is the components in a typical HO-IC Excel hand dryer.	105
Figure 57 is a SolidWorks model of our final design.	108
Figure 58 is another SolidWorks model of our final design showing the internal components.	109
Figure 59 is the side view of the final design in SolidWorks.	111

## List of Tables

Table 1 lists common infectious diseases majority of which can be found in schools (Environment,2004) . The full list can be found in Appendix A.....	13
Table 2 is a Study of the Efficiency of Surgical Scrubbing Up. ....	19
Table 3 compares the current varieties of soap to different desired objectives. Scale 1-most effective -> 10 least effective. ....	25
Table 4 is a chart of the different UV ranges.....	29
Table 5 compares the current methods of UV, Hand washing, and Hand sanitizer to different desired objectives. ....	30
Table 6 compares the current methods to different desired objectives. 1 is the most effective rating and 10 is the least effective.....	57
Table 7 - <i>Comparative Analysis of Water Filtration Systems</i> .....	78
Table 8 - Comparing Four Different Pumps (Comparing 4 Types of PD Pumps 2007).....	81
Table 9 – Comparative Analysis of Pumps .....	83
Table 10 gives a detailed description of the bacterial, viral, or fungal name, the incubation period, how the contagion is transmitted between people, and how long one is usually contagious or sick for (Environment [13]). ....	120

## Acknowledgments

Our team would like to give great thanks to our advisor for this project, Professor Mustapha Fofana. He has guided the team through the design process, as well as, taught us how to present engineering projects.



## Chapter 1 - Purpose

### Introduction

There are over 229,000 germs per square inch on a common sink faucet handle! That is over 1 million germs on the average faucet! If that was not enough to get the gears turning then maybe the fact that there are more germs on an office desk than present on an average toilet might! The spread of germs is the leading cause of illness around the world and surprisingly there is an easy solution, WASH YOUR HANDS! If humans washed their hands multiple times a day the number of sick days a year, as well as the number of illnesses, would decrease dramatically. It is most common to wash your hands after using the bathroom, coughing or sneezing, and working or playing outside. But there are many more instances where we should wash our hands like after handling animals, before and after eating, when arriving to work or school, after giving and taking medication, before and after touching your face, and in the middle of your day after using all kinds of door knobs, light switches, and other surfaces. Technology today is coming up with anti-bacterial soaps, waterless hand sanitizers, and even UV light sanitation systems to kill off germs. But, even as the Centers for Disease Control and Prevention and Department of Health, and so many other sources tell you the simplest and best way to prevent the spread of germs is simply by washing your hands multiple times a day, and not just when they physically look or feel dirty.

Today's world is filled with constant time crunches and deadlines left and right. This contributes to everyone always speeding through life to get things done and taking corners wherever and whenever is possible, which is why it is a known fact that people do not take the suggested full length of time out of their busy lives to properly wash their hands. So, the goal for this project is to continue the advanced technology theme of today's era and design a new and

improved sink. The objective is to create a device that sits in the wall like current hot air hand dryers. People will be able to simply place their hands into the device and have it do the rest. Since it is a well-known fact that people should wash their hands for about 20 seconds by traditional means and even more of a well-known fact that people do not follow this guideline; so, this projected new technology will aim for a wash and dry cycle will be approximately 12 seconds, far less than the average wash and dry cycle of current technology. This will allow people to wash and dry their hands significantly faster, so there will be no more waiting in lines for a sink and dryer because this device will do it all, quicker and more effectively and all in one cycle. Another objective of this project is to use a filtration system within the device. Utilizing a filter makes it possible to clean the water before and after use in order to conserve energy and save water! The intended technology needs to be cost effective beating or at least matching that of current sinks and drying methods. This projects overall intentions are to replace the need for sinks, paper towels, and hot air dryers by providing a one step device that saves time, is cost effective and can allow humans to wash their hands more often where ever they go.

Chapter 2 of this report is a literature review of hand washing. It goes into different types of germs in different environments, different kinds of soap and their effectiveness, and other kinds of hand sanitation techniques including waterless hand sanitizers, surgical scrubs, and UV light sanitation devices including costs of each. Also, facts about current technology, what other companies are creating to solve this issue and the mechanics behind them will be included in Chapter 2. The chapter will be concluded by researching possible filtration systems that could fit well into the intended device and choosing the best soap solution we could find from our literature review. Chapter 3 of this report involves the approach taken to the project. Explanations of the problem statement, objectives, and functions that need to be meet all within certain constraints. Detailed analysis of design alternatives and the choice of the most suitable

device from the design alternatives will be included in Chapter 3. Also included is a detailed analysis of how it well it meets the objectives, its energy and water usage as well as other components. Finally, the report is concluded with Chapter 4 discussing the accomplishments of the project as well as limitations found. Provided in this chapter are future improvement recommendations for the design and development of the project.

## Chapter 2 – Germs and Sanitation

### 2.1 Why Is Hand Washing Important

Washing hands is the number one and most effective way to prevent the spread of diseases. Hand washing aims to eliminate germs as fast as possible before contaminating objects around us and infecting other. A few main times hands should be washed include:

- Before preparing or eating food
- After preparing or eating food
- After using the bathroom
- After coughing, sneezing, or blowing your nose
- After coming into contact with animals or other human skin

\* Note: Global Hand washing day is October 15 every year!

### 2.2 Proper Ways to Wash Hands

To keep good hand hygiene one must wash hands properly. Washing ones hands involves scrubbing the hands with soap, rinsing the hands with water, and drying the hands completely.

Figure 1 is an illustration of, on average, how well hands actually get once washed.

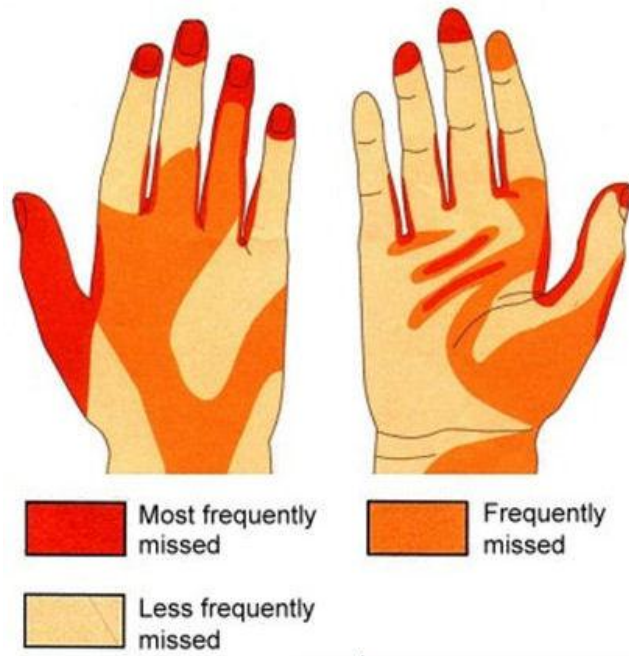

Figure 1 is a representation of the most frequently missed areas on the hands when washing. (Southeastern District Health Department, [20]).

The Center of Disease Control gives five important steps to proper hand washing.

1. Hands should be washed with soap and warm running water.
2. Hands should be rubbed for 20 seconds making sure to get backs of the hand, wrists, and between fingers.
3. Hands should be rinsed WHILE leaving the water running.
4. With the water running hands should be dried with a single-use-towel.
5. Using the towel to prevent re-contamination, turn off the water.

Sources, like the CDC as shown above, explain the importance of making sure to cover all areas of the hands and wrist, as well as making sure to NOT touch the sink after hands have just been washed to prevent re-contamination. Many health care guidelines recommend when washing hands to remove jewelry, wrist watches, and bracelets since dirt and germs can be lodged under and around them (CDC [4]).

Drying hands completely is another essential but underestimated part to washing your hands properly. It has been proven that microorganisms grow and spread more rapidly in wet environments (Rybicki [19]). When hands are left wet the skin breaks down more rapidly and leaves the potential of viruses settling into your body. According to various sources, there are three common ways to dry your hands: using hand dryers, paper towels, and cloths. Cloths are the least recommended because they can harbor germs and easily lead to cross-infection.

If soap and water are unavailable liquid hand sanitizers that contain at least 60% alcohol can be substituted but they are not effective when hands are visibly dirty (CDC [4]). Alcohol-based hand sanitizers very common since different strains of flu became prevalent years ago such as swine flu and the avian flu. “Hand sanitizers are effective in reducing the number of germs on hands but do not eliminate all types of germs (CDC [4]).” Hand sanitizers are described more in depth in section 2.5 of this paper.

## **2.3 Germs**

### **2.3.1 What Are Germs**

A germ is a microbes that can be found in the air, soil, water, on plants, humans, animals, surfaces around the home, schools, hospitals, restaurants, and just about everywhere. When the word “germ” is used there is a common negative notion about it but germs can be helpful as well. The two main types of germs are bacteria and viruses.

The main difference between bacteria and viruses is that bacteria are a unicellular prokaryotic microorganism, meaning they are single celled organisms that lack membrane-bound organelles like a nucleus or mitochondria. A bacteria cell seen under a microscope is illustrated in Figure 2. They have their own set of DNA and RNA and are able to self-reproduce. Bacteria reside in almost every habitat on earth including living inside other living organisms or on top of

nonliving surfaces. Bacteria are generally larger than viruses. Approximately 99% of bacteria are actually harmless to humans because they break down organic matter that spreads infections and destroy harmful parasites (Thobaben [25]). Bacteria usually cause infections due to toxins and acids they release but these infections can usually be treated with antibiotics.

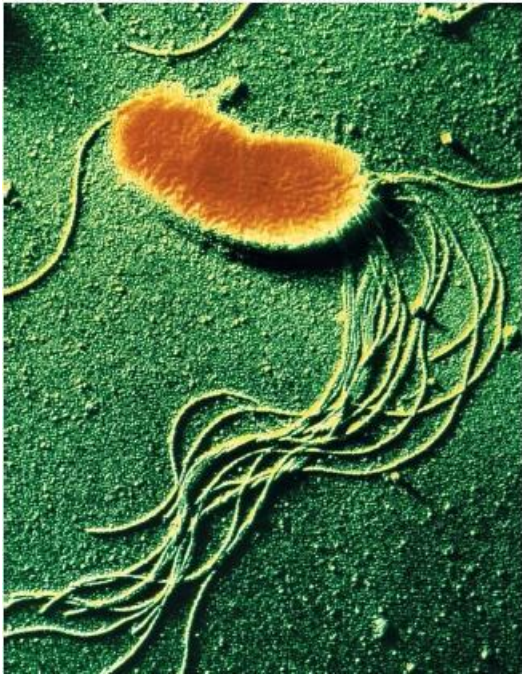

Figure 2 is an electron micrograph of a soil bacterium, *Pseudomonas fluorescens*. (Rybicki [19]).

Viruses are much smaller than bacteria. They are also acellular, non-living, organisms. Viruses need a living “host” to live and reproduce. So unlike bacteria they are unable to thrive anywhere on Earth. After a virus finds a host it replaces the host’s DNA or RNA with its own genetic instructions to spread. Unfortunately viruses are not helpful to us like bacteria; some of the common illnesses they cause are shown in Figure 3. To treat a virus a vaccine or an antiviral drug is needed (Thobaben [25]).

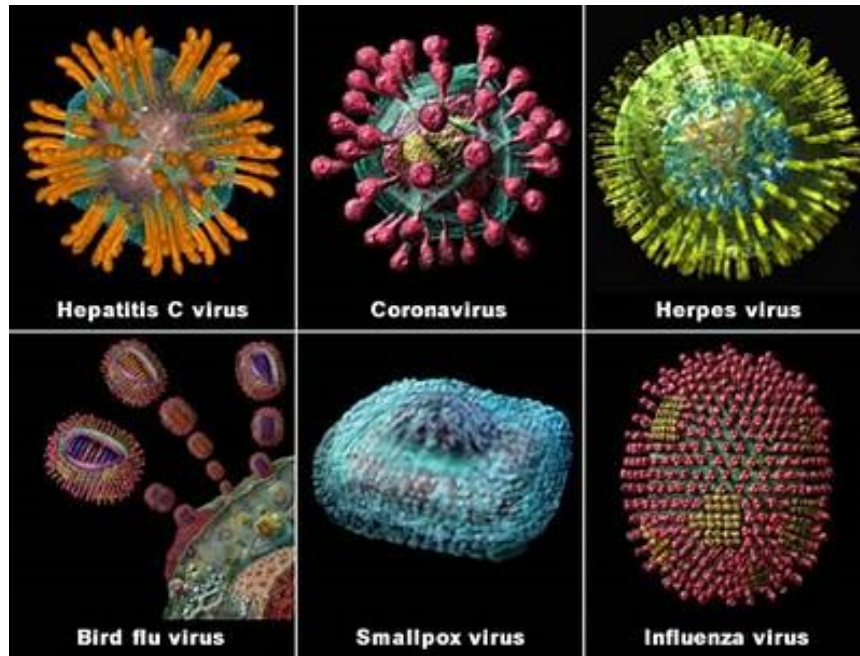

Figure 3 shows the structure of common illnesses caused by viruses (Rybicki [19]).

There is a wide antimicrobial spectrum: gram-positive bacteria, gram-negative bacteria, mycobacteria, fungi, positive and negative envelope viruses, bacterial spores, and oocysts but for our purposes we are going to focus on the common germs bacteria and viruses as a whole instead of broken up into the different categories of the antimicrobial spectrum (Rybicki [19]).

### 2.3.2 Where Are Germs Found

The important locations for good hygiene are healthcare institutions, within the food industry comprising of restaurants and supply chains, in domestic settings, and areas within the community including schools, malls, grocery stores, recreation centers and many more. In 2005 reported 2-3 million deaths due to diarrheal diseases that could be prevented. It has been estimated hand washing with soap could reduce incidences of diarrhea by 42-47% save 1 million lives a year (Thobaben [25]).



## Hospitals and Nursing Homes

There are many germs that survive better in a hospital environment including; *Staphylococcus aureus* (commonly known as a staph infection), Enterococci (is a lactic acid bacteria that are commonly found in feces), and Gram-negative bacilli (common examples are *E. coli* and *Salmonella*) (Fraser [15], Todar [26]). These hospital microorganisms are pathogenic for humans and can produce urinary tract infections, growth of bacterium, fever, diarrhea, and other infections (Thobaben [25]).

In health care settings pathogens can be transmitted from patient to patient through bodily fluids, infections on the skin, skin to skin contact with a patient, or contact with an object the infected patient has recently handled. Healthcare workers are employed to handle and help patients, so contact is inevitable. Germs can be transferred when taking a blood pressure on different patients, using communal wheelchairs or beds, using unchanged gloves, and other non-sterile instruments. A number of studies have actually shown that because health care professionals where gloves more often they are less likely to wash their hands between patients (Thobaben [25]).

## Within the Community: Schools, Restaurants, Malls

Not only can germs linger on our skin but they also reside on and in our common inanimate environment. Domestic Residents are filled throughout with germs. In homes, families touch everything. Doorknobs, counters, handles, refrigerators, chairs, the television remote, telephones, beds, toys, magazines, bathrooms, sinks; everything in our house has bacteria and viruses on it. Kitchen sinks and sponges are actually considered breeding grounds for microorganisms like the bacterium *E. coli* (Dunkin [10]). This is simply because people give them less attention than things like the toilet, which on average will actually be cleaner.

Schools are an environment that germs thrive simply because they aren't clean. Children are not always aware of what germs are, how they spread, and their affects. Thus they do not understand the importance of hand hygiene causing a germ infested environment. When a person touches their face, eyes, mouth, or nose they become infected with germs from their surroundings. In schools, students are in contact with one another and transfer these germs all the time. Germs mainly spread when students cough, sneeze, talk and then touch their surroundings without washing their hands. Common germs found in schools are the common cold, strep throat, pertussis (also known as whooping cough), conjunctivitis, and the chickenpox (Colorado Department of Public Health and Environment, [6]).

Places in the bathroom whether it be in a home, mall, or restaurant are filled with germs, from the sink to the bath tub, to the towel you wash your hands, to the cabinet in the bathroom, and even personal products like toothbrushes. When flushing the toilet, virus and bacteria contaminated water droplets spray into the air. What doesn't fall and coat your bathroom floats in the air for up to two hours after each flushing (Dunkin [10]). TV remotes and computers are also thriving with germs simply because we use them every day before eating, after eating, when sick, and they are less often cleaned.

### 2.3.3 Spread of Germs

The spread of infectious diseases are separated into six categories; *Droplet Transmission/Infectious Discharges, Airborne Transmission, Fecal to Oral Spread, Direct Contact, Body Secretion Contact, and Sexually Transmitted Diseases* (Colorado Department of Public Health and Environment, [6]). This paper focuses on the first five categories that are the main routes of germ transmissions.

*Droplet Transmission/Infectious Discharges* are commonly spread through respiratory tract symptoms which result in discharges of the mouth and nose; including coughing, sneezing, and even

talking (meaning sore throats). Droplets can travel up to three feet when being discharged (Colorado Department of Public Health and Environment, [6]). These germs will fall on surround body parts, clothing, furniture, equipment, food, and people.

*Airborne Transmission* is not a common mode of germ transmission. When people cough, sneeze, and talk they expel particles but it is less likely these particles contain viruses and bacteria that disperse through the air. Measles and tuberculosis are two diseases that can be spread through airborne transmissions but again they are rare (Colorado Department of Public Health and Environment, [6]).

*Fecal to Oral Spread* is more common than one would think. Feces contains viruses, bacteria, and parasites that when ingested cause infections. This kind of transmission is commonly from toilet flush handles, faucet handles, and when in contact with diapers. Also if one does not wash their hands thoroughly after using the bathroom, some fecal matter could remain on ones hands, therefore increasing the probability transmitting the pathogen to oneself or others around. Salmonella and E. coli are the two most common microorganisms that are seen today for this transmission route (Thobaben [25]).

*Direct Contact* transmission is simply when germs from one person's skin comes into contact with another person's skin. This usually occurs when people shake hands or contaminated clothing.

*Body Secretion Contact* can come from various sources including cuts or open areas of the skin come into contact with another person's blood or body fluids, biting and breaking of the skin commonly found with animals, and human interactions like kissing. Body fluids are considered blood, urine, seminal fluid, cervical fluid, and saliva. Hepatitis B and C, and HIV are common diseases that can be spread through body secretions.

## 2.4 The Skin

On average there are 100 million germs/ cm<sup>2</sup> on a person's skin (Thobaben [25]). To understand how germs affect humans it is important to understand the skin. The skin is one of the main immune defenses our body relies on daily. The skin is made up of several different layers

of dermis, with the top and most important being the epidermis. On this layer, many natural bacteria are found and aid our body in protection against foreign, or invasive, species of bacteria. These good bacteria metabolize, or consume the foreign bacteria and produce fatty acid chains that prevent other invasive bacteria from colonizing and thriving on the epidermis. The skin also naturally produces enzymes to degrade those invasive species that escape the natural flora of the skin, which serves as another natural defense by our body.

In order to fully appreciate the power of the skin, one must know what is contained in the secretions it produces, along with other forms of innate defenses the body utilizes. The main secretions through the skin are lysozymes, complements, polypeptides, lactoferrin and transferrin, peroxidase, and fibronectin. The two most powerful of these against bacteria are the enzymes lysozyme and peroxidase. These enzymes cause the bacteria at hand to lyse, or break open and die. Though the mechanisms of each protein are different, the end function is the same and very effective. The other substances listed function by either inhibiting growth of bacteria through taking away a certain nutrient needed for bacterial growth, or through signaling the internal innate immune system through inflammation or opsonization, which in the end kills off the invasive species.

The mechanisms the skin utilizes, as listed in the previous paragraph, are used against a wide array of contagions that circulate in the environment. Some differences in species/strains/serotypes are noticeable as one travels from region to region, or even just from a school to a hospital. Shown in Table 1 is a list of several common contagions; being viruses, bacteria, or fungal in nature (Environment, 2004).

Table 1 lists common infectious diseases majority of which can be found in schools (Environment,2004) . The full list can be found in Appendix A.

DISEASE/AGENT	INCUBATION PERIOD	TRANSMISSION	CONTAGIOUS PERIOD
<b>E. coli O157:H7 and other Shiga Toxin Producing Bacteria</b> <i>Escherichia coli</i> bacteria	2-10 days (usually 3-4 days)	Fecal-oral spread, contaminated food/water, animals	While diarrhea is present; can spread for 1-3 weeks after symptoms are gone
<b>Fifth Disease</b> Human parvovirus B19	4-21 days	Droplet/infectious discharges	1 week before rash formation
<b>Genital Herpes</b> Herpes simplex virus	2-14 days	Sexual transmission	Potentially lifelong
<b>Genital Warts</b> Human papilloma virus	1 month-several years (usually 2-3 months)	Sexual transmission	Potentially lifelong
<b>Giardiasis</b> <i>Giardia lamblia</i> parasite	3-25 days (usually 7-10 days)	Fecal-oral spread, contaminated food/water	While diarrhea is present; can spread for months after symptoms are gone
<b>Gonorrhea</b> <i>Neisseria gonorrhoeae</i> bacteria	2-7 days	Sexual transmission	Until treated
<b>Hand, Foot and Mouth Disease</b> Strains of enteroviruses	3-6 days	Droplet/infectious discharges, fecal-oral spread	During the first week of illness; virus can be present in stool 4-6 weeks
<b>Head Lice (Pediculosis)</b> <i>Pediculus humanus</i> , the head louse	Nits hatch in 10-14 days, adults live 3-4 weeks	Direct contact with an infested person/object	As long as live lice are present
<b>Hepatitis A</b> Hepatitis A virus	15-50 days (usually 25-30 days)	Fecal-oral spread, contaminated food/water	Most contagious 2 weeks before symptom onset and slightly contagious 1 week after jaundice onset
<b>Hepatitis B</b> Hepatitis B virus	2-6 months (usually 2-3 months)	Infective blood or body fluids, sexual transmission	Several weeks before symptom onset and throughout the illness, some

As one can see, Table 1 gives a detailed description of the bacterial, viral, or fungal name, the incubation period, how the contagion is transmitted between people, and how long one is usually contagious or sick for. The incubation period is the time where the contagion is in one's body, yet no symptoms are present. This is the time where the viruses and bacteria grow logarithmically inside each cell, then use their particular mechanism to spread themselves throughout the entire system they feel most at home in. It is in this period where the innate immune system tries hunting down the contagion and killing it off before any harm is done, usually with macrophages, neutrophils, and monocytes mainly through signaling bodies called cytokines and chemokines. If the innate immune system is unable to fully fend off the contagion, it signals the adaptive immune system to kick in, which is comprised of the innate immune system with all of its components, as well as different types of T-cells and B-cells.

The main way the adaptive immune system works is through presentation of segments from the captured and disintegrated bacteria, virus, or fungus to the T-cells and B-cells, which then differentiate into their effector molecules which are specific for that certain sequence now, or will then pass that sequence on to a naïve cell to stimulate it to aid in the upcoming fight against the pathogen. Generally speaking, the T-cells differentiate into two subsets, cytotoxic CD8+ T-cells, whose main functions are to search and destroy anything that it finds with the same protein sequence it was stimulated by, and helper CD4+ T-cells, who help in stimulating more and more naïve cells with sequences from the same pathogen. B-cells differentiate into plasma cells, whose function is to secrete antibodies into the body that aid in fighting off the pathogen by binding to it and either signaling a T-cell to come and destroy it, or neutralize the pathogen to make it ineffective, or they could also bring it to another part of the cell for it to be digested there. All in all, the internal immune system works very well if the solid wall of skin is opened for any reason, however it is always best not to chance it since so many bacteria are becoming antibiotic resistant, and one never knows how the pathogens will mutate next to possibly create a superbug or super virus.

The solid defenses are nullified if the skin breaks apart from a cut, scrape, gash, etc. The invasive species then have a greater chance of entering our body, colonizing, and possibly wreaking havoc on our internal defenses, and giving us a particular sickness that species specializes in. Therefore it is in particular interest of ours to keep the skin intact. Having emollients in the wash would allow for this, since they moisturize the skin, while the other components of the wash, such as the alcohols and ammonium-compounds, would cleanse. As of now, the hand washes that are normally seen throughout the public are the best that are out for the use of common man. It is in our interest to find out if there is a way to make a more effective wash for commercial use that is also in the same price range.

## 2.5 Different Hand Disinfecting Techniques

### 2.4.1 Soaps

#### 2.4.1.1 Everyday soap

When the regular person washes their hands in a restroom, the regular protocol is to wet the hands, apply a soap, rub and rinse for 15 to 30 seconds under warm water, then to dry ones hands fully. This protocol is made possible by applying the soap when the hands are wet and to allow the compounds in the soap to do their jobs. So what exactly does soap do to cleanse the hands and how many different types of soaps are out there?



Figure 4 illustrates the common liquid hand soap, Softsoap gallon-size container.

The common liquid hand soap that is found in almost every bathroom in public has a simple make-up and process in cleansing, such as found in Fig. 4. Regular hand soap is made up of fats and alkali metals (usually potassium hydroxide for liquid soaps and sodium hydroxide for solid soaps). The fats are what allow the dirt and germs to be removed from the hands, since the dirt and germs have chemical tendencies to bind to the non-polar substance. The alkali metals allow the process of soap making to occur, by transforming the fats into fatty acid chains, and then into glycerol. The reaction that these soaps have is shown in Figure 5.

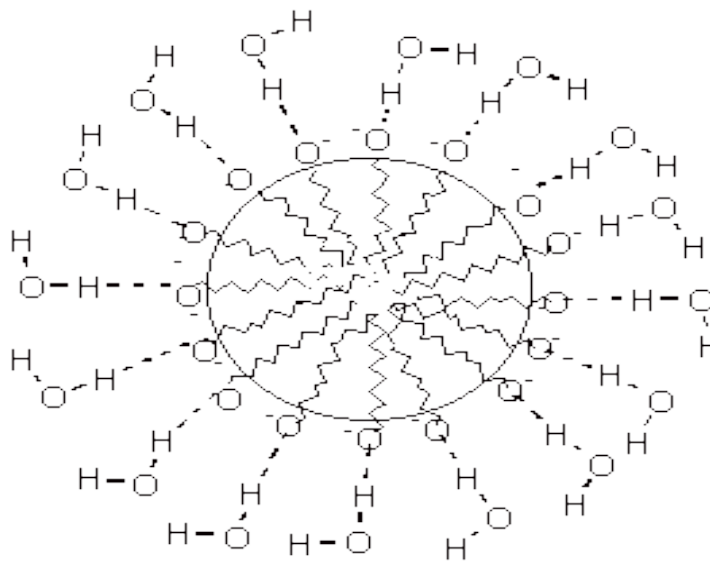

A Soap Micelle

Figure 5 illustrates the chemical property of soap.

As one can see, a soap micelle, or an aggregate of compounds in a solution, is formed. This micelle will then be uplifted from the hands when they are being rubbed together from frictional forces, and then washed away once the water hits the micelle. That is how the everyday commercially used public hand soap works.



Figure 6 is a common solid bar soap, Dial antibacterial soap.

Basic hand soaps as just discussed work well for day-to-day use, however they are not the best cleansers that are out today.



#### 2.4.1.2 Surgical scrubs

Everyday bathroom soaps are inferior to surgical scrubs, which are used by doctors on their hands and forearms before going into surgery, or another situation where sterility is of utmost importance. A scrub called *N*-Duopropenide supposedly works better than many other hand cleansing techniques, and it also works better over a longer time period (Herruzo-Cabrera, 1999). This paper was published in 2000 by Spanish scientists, and it surprises me that this advance in hand washing technology was not utilized in a commercial level.

*N*-Duopropenide is a compound made from ammonium iodides and formaldehyde (Curehunter, 2003-2011) which aid in killing off viruses and bacteria through disinfection and the formaldehyde also prevents new bacteria and viruses from growing where it has been applied. The ammonium iodides are quaternary, and the ones used are: benzyldimethyldecadecylammonium, benzyldimethyltetradecylammonium, and benzyldimethylhexadecylammonium (Redondo, 1997). Keeping the contagions at bay is necessary with any sanitation product, but other factors come into play such as the complete killing of the contagions, which the ammonium iodides and formaldehyde can't perform completely. This is where the 60% alcohol component comes into play. 60% isopropyl alcohol is commonly found in the liquid hand sanitizers seen everywhere these days. The dehydration effect on anything it comes into contact with destroys bacterial cell membranes and virus capsules. This effect can be quantified to up to 99.9% of germs being killed with each use. While dehydrating the germs on ones hands is good, keeping a protective barrier intact, as the skin is, is more important because even if the germs on the hand are killed, the cracks formed in the skin will create a nice environment for other contagions to thrive in that could get on the hand when it comes into contact with any other object that is not sterile. That is where the third aspect of this solution comes into play. The emollients will moisturize the skin, which in turn prevents the skin from painfully cracking, which is characterized from using hand sanitizers a

lot. This moisture would be a flaw concept in developing a good hand scrub since bacteria flourishes in moist environments, but the bacteria will be long gone because of the ammonium iodides and isopropyl alcohol, and the formaldehyde will keep the bacteria and other germs at bay while the hands are getting this moisture. So not only will this hand scrub kill off the same amount of germs as regular hand sanitizers, it has emollients to keep the hands moist, and it has formaldehyde to prevent more contagions from colonizing on the skin after the hand washing.



Figure 7 is the common surgical scrub, Chlorhexidine 2% solutions and 4% solutions.

In Table 2 and Figure 8 and 9 taken from R. Herruzo-Cabrera's paper titled: Usefulness of an Alcohol Solution of *N*-Duopropenide for the Surgical Antisepsis of the Hands Compared with Handwashing with Iodine-Povidone and Chlorhexidine: Clinical Essay.

Table 2 is a Study of the Efficiency of Surgical Scrubbing Up.

**Study of the Efficiency of Surgical Scrubbing Up with Three Products on Cutaneous Germs ( $n = 15$  healthy volunteers), Expressed as Log CFU/5 Fingertips<sup>a</sup>**

Time	4% Chlorhexidine		7.5% I-pov		2.3% NDP-alc	
	$\bar{X}$	SD	$\bar{X}$	SD	$\bar{X}$	SD
Before washing	4	0.5	4	0.4	3.9	0.4
After washing	<1	—	3.1	0.2	<1	—
+1 h	2	0.3	4.3	0.9	<1	—
+3 h	2.7	0.6	4.5	1.2	<1	—

**Bivariant analysis**

*1. Time*

"Before"	$P > 0.05$ (NS)
"After"	I-pov > (**) chlorhexidine (NS) NDP-alc
+ 1 h	I-pov > (**) chlorhexidine > (**) NDP-alc
+ 3 h	I-pov > (**) chlorhexidine > (**) NDP-alc

*2. Products*

I-pov	Before > (**) after + 3 h > (*) after + 1 h > (*) after Before (NS) + 1 h (NS) + 3 h
Chlorhexidine	Before > (**) + 3 h > (**) +1 h > (**) after
NDP-alc	Before > (**) + 3 h (NS) +1 h (NS) after

<sup>a</sup> I-pov, iodine-povidone; NDP-alc, *N*-duopropenide in alcohol; NS, no significant differences.

\*  $P < 0.05$ .

\*\*  $P < 0.01$ .

This source uses Three Products on Cutaneous Germs ( $n=15$  healthy volunteers), Expressed as Log CFU/5 Fingertips<sup>a</sup>. Table 2 shows how the three surgical scrubs compared to each other after the in vivo tests against cutaneous germs. To summarize the table, the iodine-povidone wash did the worst out of the three, by not killing as many germs right off the bat, and after some time passed more germs colonized on the hands than did with the other two washes. Figure 8 and 9 help show the test results.

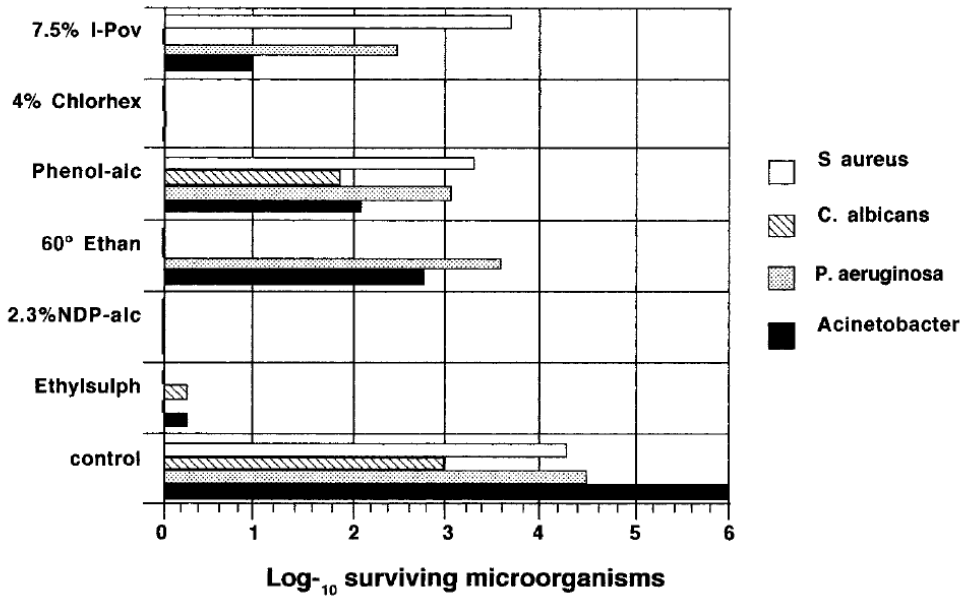

Figure 8 illustrated In vitro germicide effect of six products (four alcohol solutions) for 3 min in a model of infected skin.

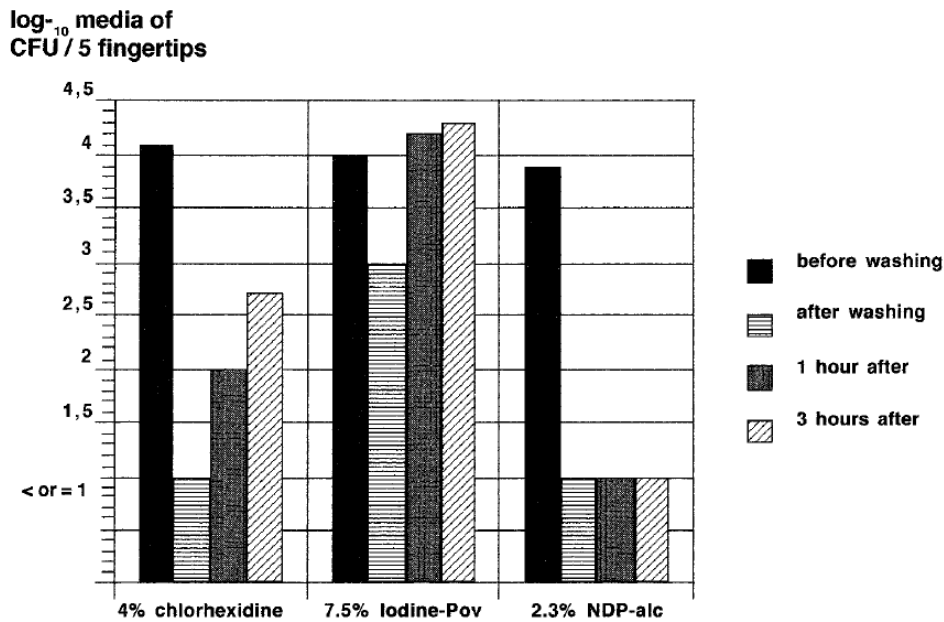

Figure 9 is from the study of the efficiency of surgical scrubbing up with three products on cutaneous germs.

Chlorhexidine finished second by killing basically just as many germs as *N*-duopropenide did, but as time passed germs steadily colonized the washed areas again. *N*-duopropenide killed off a lot of the germs in the washed area, and kept the germs away significantly, even three hours after the wash was applied. Figure 8 depicts simply the killing skills of six cleansers in the test

against common germs found on hands. As one can see the *N*-Duopropenide solution has little to no logarithmic growth, indicating the best killing. Then in Figure 9, the same *N*-Duopropenide solution is compared to the other two cleansing solutions found in Table 2 by growth of CFU (colony forming units) over time. Again *N*-Duopropenide reinforces the fact that it is a better cleansing solution right away, and over a period of time after cleansing than the other two surgical scrubs tested.

Having a top notch cleansing and sanitizing solution such as *N*-Duopropenide with 60% alcohol and emollients is ideal for most circumstances that are dealt with in the day-to-day lives of the common man. A way to make this system of washing better would be to have a way to diversify the technology so every human can use it, which would include the elderly and babies as well.

#### **2.4.1.3 Soap for Elderly and Babies**

The elderly and babies have different skin types when compared with the average person between the ages of around 10 to 60. As one grows, their skin becomes better suited to fighting off microorganisms trying to invade via the skin, better moisturized, and also more durable to the stray nick and scratch. When one speaks of babies, one is talking of a fragile life form that is not yet resistant to most outside stimuli. Their skin is soft and tears easily. Their immune defense is also low because they have not been introduced to any contagion before. It is in our interest to have a soap that will cater to babies needs as well. Having an option on our mechanism to dispense baby soap would be beneficial to many that are out and about with their children, which is why there are baby changing stations in bathrooms in the first place. This way parents with newborns or young children have an easy option when out in public.



Figure 10 shows *bare organics*, an organic baby soap with no scent.

Babies have very sensitive and fragile skin. They also need to be washed by their guardian or whoever is taking care of them since they are not old enough to wash themselves. This may create some difficulty in the process since the baby may squirm and wiggle since it is a new experience to them. The squirming and wiggling could cause the soap to end up in their eyes or other parts of their bodies that soap usually should not end up. This creates a need for the soap to be simple, chemical free, hypoallergenic, tear-free, and moisturizing all in one. So when one decides to buy baby soap from the store, or make one themselves, the ingredients usually used are the basic water, oil, and glycerin to start with. This is the base of most soap. These components alone would suffice to cleanse and be gentle on a baby's skin, yet it would do nothing to moisturize it. This is where natural oils come in handy that help the skin strengthen. Some examples of these oils would be: vitamin E, jojoba oil, castor oil, lavender oil, almond oil, shea butter, olive oil, and coconut oil (Todar [26]). These are all natural oils that have immune supporting properties as well as moisturizing properties. Since they are all-natural, one does not need to be concerned with harsh chemicals affecting the baby's sensitive skin, or causing tear production in their eyes.

Baby soap is not the best at cleaning hard grime and dirt off skin, since babies don't really run around enough to get that type of filth on themselves. Its main purpose is to gently dislodge the particles of dirt, dead skin, and excrement from the healthy skin, and wash it away while moisturizing. This sort of cleaning would not work well for the elderly. The elderly still need that gentle washing that a baby requires however there is a higher likelihood of dirt and grime being rubbed deeper into the skin. Moisturizers would still be necessary as well, since the epithelial tissue layers tend to die off quicker as people age, so the moisturizers will keep the skin that is left healthier, longer. This is beneficial since as aforementioned the several layers of epithelial tissue are one of the barriers our bodies use for protection against foreign contagions. This is why some suggest using regular hand soap with aloe in it. The aloe will aid the skin in revitalizing after the soap has cleansed the surface and grooves in the skin.

#### **2.4.1.6 Dirt & Grime Soap**

While having soap for everyday use for public places, a hardcore cleaning surgical scrub for those more interested in a product like that, such as hospitals, nursing homes for the employees, and possibly restaurants, and gentle cleansers for babies and the elderly to utilize, what about the regular blue-collared working man? The type of workers singled out here would be the hands-on laborers such as construction workers, landscapers, painters, and buildings and grounds faculty. These workers get grit and grime ground into their skin from the labor they perform. Painters and carpenters get caulk, paint, primer, etc pasted to their hands which is hard to remove. A regular hand soap is not going to get whatever is stuck on their hands fully off no matter how much scrubbing is done, and neither will the surgical scrub. Yes, a form of soap that works well for the elderly would work well as a second wash for these guys after the grime is removed to rejuvenate their skin, but using it as a primary soap will not do. This is where a type of soap formulated with small beads or crystals in it works well since they can dig into the skin with enough friction to get all that mess off the skin.



Figure 11 is a common heavy-duty scrub, Gojo Pumice Hand Cleaner.

One product that works well that covers all the bases for this issue is the Go-Jo Cherry Gel Pumice Hand Cleaner. It is a gel that contains tiny pumice scrubbers in it to scrub away the tough dirt particles that gets lodged in skin crevices (Gojo, 2011). The gel is also able to remove grease, which means it contains certain fats to remove it, and it also conditions the skin with moisturizers to keep it healthy and refreshed. This gel has the qualities that any good industrial-grade hardcore soap should have, the only difficulty in adapting it for use in our hand washing system is the pumice scrubbers may be too large to escape the sprayer that will apply the wash of choice to ones hands. A separate assemblage could be created for this type of usage where it's a more manual squirt, rub, and rinse process though.

#### 2.4.2 Comparison of Different Types Soaps

After discussing the several soap possibilities to utilize in the hand washing system, a pair-wise comparison chart was made to help analyze the data better. It compares the several hand cleansers by price, how well they kill germs, the time it takes them to kill the germs, how easily they are bought, and how they affect the skins overall health. They were ranked from one



to ten, with one meaning they are good in that field, and ten means they do not come up to par in that category. They are totaled in the rightmost column and the lowest score should mean that the particular product would work the best in a general hand washing system.

**Table 3** compares the current varieties of soap to different desired objectives. Scale 1-most effective -> 10 least effective.

	<b>Cost</b>	<b>Killing Germs Ability</b>	<b>Time Kill Germs</b>	<b>Accessibility</b>	<b>Affects On Skin</b>	<b>Totals</b>
<b>Regular Soap</b>	3	7	5	2	3	10
<b>Surgical Scrub</b>	9	1	2	8	2	22
<b>Elderly Soap</b>	3	8	6	2	2	21
<b>Baby Soap</b>	3	8	7	2	1	21
<b>Hardcore Dirt Soap</b>	6	5	5	4	5	25

As one can see in Table 3 the regular hand soap has the lowest total from the soap subcategories listed in the table, therefore being the best contender for use in the hand washing system. This was expected since it works decently well in an equally average amount of time for a low cost. The elderly soap and baby soap were both next in comparison, mostly due to the cost of their manufacture. If the cost is eliminated from the table, the surgical scrub would be the best choice since it works the best and it would not be too difficult to manufacture and/or order. It would also be plausible to argue that the surgical scrub could be utilized for a wide array of uses,

such as conventional soap is, if it is watered down slightly to reduce its possible agitative effects on the skin. This idea along with having a cheaper manufacturing cost is brought together, the *N*-Duopropenide solution would be the best option to dispense in the hand washing system since it works the best out of them all and the quickest as well.

### 2.4.3 Hand Sanitizers

Cropping up everywhere since H1N1 influenza started getting passed around a couple years ago are hand sanitizers. They appear everywhere in schools, hospitals, workplaces, malls, and other high volume community areas where germs are more easily spread via human to human contact. Hand sanitizers are a very simple idea that functions very well. They are also pretty cost effective since only around a 2.5mL squirt on a hand is enough to rub around to remove 99.9% of germs from ones hands (Thobaben [2010]). The main question though, is are they safe enough and do they work well enough for the general populace to use instead of a soap in the hand washing mechanism?



Figure 12 is a common hand sanitizer, Purell with aloe.

When typing in hand sanitizer in a search engine, quite a few of the hits are on safety issues dealing with children using hand sanitizers. This is because young children put their hands in their mouths a lot, and tend to consume strange new things to them, such as dirt, glue, plastic, and even hand sanitizer. This is dangerous entirely because of the ingredient that allows hand sanitizers to actually function correctly, the isopropyl alcohol. Isopropyl alcohol is used widely as a solvent since it dissolves non-polar compounds very well, such as oil. The main usage for isopropyl alcohol, however is in hand sanitizers since it is so effective at killing germs in a short period of time. It also has the added bonus of evaporating once rubbed into the skin. These two properties of isopropyl alcohol are the sole reasons hand sanitizers work.

Many studies suggest that 60% alcohol in hand sanitizers is the minimum strength one should use for it to be effective, which is contrary to what some had previously believed to be true. When 40% alcohol solutions were compared to the 60% alcohol solutions, the difference was noticeable enough for the CDC to post a statement concerning hand sanitizers and their formulas (CDC [2011]). Now most if not all hand sanitizers must contain between 60% and 92% ethanol or isopropyl alcohol, with isopropyl alcohol being the most common.

Increasing the concentration of alcohol in hand sanitizers is great to clean ones hands, but it is dangerous within grade school settings. As mentioned before, young children always seem to be putting things in their mouths. If they ingest enough hand sanitizer, they could become intoxicated and possibly die if enough is consumed. They become intoxicated because the isopropyl alcohol gets broken down by alcohol dehydrogenase into acetone, which causes the typical signs of drunkenness, being dizziness, slowing of central nervous system control, vomiting, nausea, and coma possibly. Needless to say, this is not the type of product some parents want their young ones exposed to. Children consuming hand sanitizer is a large enough

amount to cause any harm does not happen often due to adult supervision and heightened awareness about the possible dangers.

An issue with having a higher alcohol content in hand sanitizers is the alcohol's dehydration effects on the skin. In order to keep hand sanitizers functions the same, one cannot exclude the alcohol portion since it actually does the killing of the germs. So to combat the alcohols drying effects, many companies include vitamins and moisturizing agents to help protect the skin. These vitamins and agents would be very similar to those found in baby soap, with vitamin E and aloe vera being the two most popular. Vitamin E aids the immune system in combating contagions on the skin surface, while aloe vera helps soothe and rejuvenate the skins health after the alcohol dries it out and kills off the superficial germs, and those that it was able to reach before it evaporates. Other than isopropyl alcohol with certain moisturizers and/or vitamins added, hand sanitizers are pretty even across the board as far as their ingredient list and how they function.

## **2.4.4 UV sanitation**

### **2.4.4.1 What is UV light**

UV light, also known as Ultra Violet Light, is outside of the visible spectrum. There are three ranges of ultra violet light; A, B, C. UV-C light is the most common range. It is a short wave spectrum from 280nm – 200nm. They generally come directly from the sun.

Ultra Violet light emits radiation and is extremely harmful against microorganisms. UV-C is a germicidal wavelength at 253.7nm. It can disinfect air, water, and other surfaces against germs. It is used in in sanitation by breaking down germs molecular bonds destroying their nucleic acids. This disinfection is a photochemical process where the germ's cell membrane and

DNA are broken down upon exposure. The germ's molecular bonds are ultimately destroyed rendering the germs sterile because the germs can no longer reproduce.

#### 2.4.4.2 Danger of UV light

Direct exposure to Ultra Violet light is extremely dangerous. It can cause burns on the skin. Table 4 shows the different characteristics of UV-a, UV-B, and UV-C light.

Table 4 is a chart of the different UV ranges.

Region	Also known as	*Range in nm	Hazard Potential	Damage Mechanism (High Exposures)
UV-A	near UV	320-400	lowest	cataracts
UV-B	mid UV	290-320	mid to high	**skin or eye burns
UV-C	far UV	190-290	highest	skin or eye burns

\*Early "black lights" emitted in the range of 360-390 nm.

\*\* Increased risk of some types of skin cancer.

Long term exposure can lead to ulceration and skin cancer. If UV light enters the eyes it can burn the epithelial tissue. Many sources have said that UV-C cannot cause cancer or cataracts but it is still not universally accepted. Another danger in using Ultra Violet light lies within their bulbs. UV bulbs contain mercury (Environmental Health & Safety, [13]).

### 2.5 Comparison of Soap, Hand Sanitizers, and UV Sanitation

The three different methods to killing germs all have advantages and disadvantages. Table 4 is a pairwise comparison chart comparing the effectiveness of each method. It can be seen that hand soaps and sanitizers are close in effectiveness. An important objective to point out is that soap has a much better ability to clean grime and for the purposes of this project are more significant. Table 5 was created by the team to compare the different hand washing methods.

Table 5 compares the current methods of UV, Hand washing, and Hand sanitizer to different desired objectives.

Methods/ Objectives	Safety	Ability Kill Germs	Cost	Availability	Water Usage	Energy Usage	Clean Grime	Totals
UV Sanitation	8	3	5	4	1	7	9	37
Soap	3	7	3	3	5	4	2	27
Hand Sanitizers	4	5	3	3	1	2	8	26

Hand soap and hand sanitizers show to be most effective. 1 is the most effective rating and 10 is the least effective.

## 2.6 Current technology

### 2.6.1 Sinks/soap dispensers

Figure 13 is a traditional sink found in a majority of households and restrooms across the world.



Figure 13 is a common bathroom sink (Sinks n.d.).

Sinks vary in shape and size but all together they share the same function. These sinks have one primary function, to allow people to wash their hands with water provided by the faucet attached to the sink, and hopefully with soap dispensed right near the sink.

The problems faced with these fixtures is that for the most part they are not the most sanitary surfaces having all the grim, dirt and bacteria from people's hands washed into it. These fixtures are entirely at the whim of their owners to be clean and sanitary, there is no means of them doing self cleaning which after one person, and even just after sitting there for a while unused leaves millions and millions of bacteria able to form and stay on the surface of the sink basin and the faucet. Not to mention the fact that these fixtures are not the best on saving or conserving water by any means because they do not utilize a filtration system connected into the drain of the sink basin. If there were to be a filtration system at the end of the process gallons upon gallons of water could be recycled with ease and potentially provide cleaner water into the system itself because it goes through multiple layers of filters before rejoining the flow line to the faucet.

Some work has been put into these fixtures to try to address some of these problems, such as to help eliminate the need to touch the device with a motion sensor so germs and bacteria are not spread from coming in contact with the faucet itself. The motion detector used here waits for an object like a hand to be placed in front of the sensor, which is usually placed below the faucet's spout so that once the field of the sensor is broken by the hand it triggers water to start flowing, and will shut off again once the hand is removed from the sensor's field. Also, some faucets have a timer in place to cut the flow of water after the suggested length of time specified by the manufacturers in order to address the conservation of water problem. This works in a manner that once the faucet is turned on it starts a timer that will stop the water at a preprogrammed time.

Some problems akin to those of the sink are also included with the thought of the soap dispensers generally used in public. These devices for the most part carry as many germs and sometimes more germs than toilet seats even. The pitfall of this device is that it comes in contact

with the most germs because it is one of the first stages in the cleaning process and is used while hands are at the dirtiest. But, there have been advances in this as well, and just like the sinks mentioned above, the soap dispensers to have had motion sensors added to them in order to help prevent and ease the spread of germs through contact. An average soap dispenser is shown in Figure 14 as a rough sketch from a patent design. As can be seen there is no motion detector on this particular device, instead there is a simple push bar at the bottom of the device that once pressed starts to release the soap into the user's hand, or whatever else might be below the nozzle. The process that is involved with this release of the soap is rather simple, once the bar at the bottom is pressed a roller is triggered from inside the unit and rollers over a tube inside that holds a pre-portioned amount of soap inside. The roller rolls over this tube and extracts the soap by means of forcing it to the nozzle end at the base of the device, and once the pressure is enough the soap will be dispensed (Maddison and Dawson [17]).

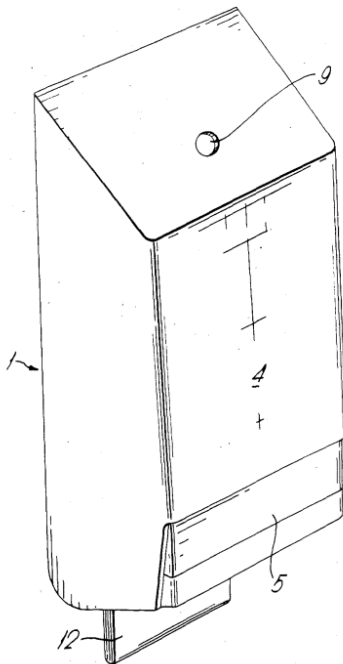

Figure 14 is a Kimberly-Clark soap dispenser (Maddison and Dawson [17]).



There also slightly more advanced dispensers for soap, the majority of which are found in hospitals with the surgical scrubs. These devices use electromagnetic energy in the form of infrared light in order to operate, as well as just involve more of a process for the dispersal of the liquid soap. From the outside the device looks extremely simple but on the inside all the mechanisms behind its operation from the rollers and base pad to the batteries that power the electromagnetic energy this device is much more complex than the previously stated one. Two images of this patented device are shown in Figure 15. The image on the right is the interior components of the device and the image on the left is an exterior image of the device as a whole (Albert and Thompson [2]).

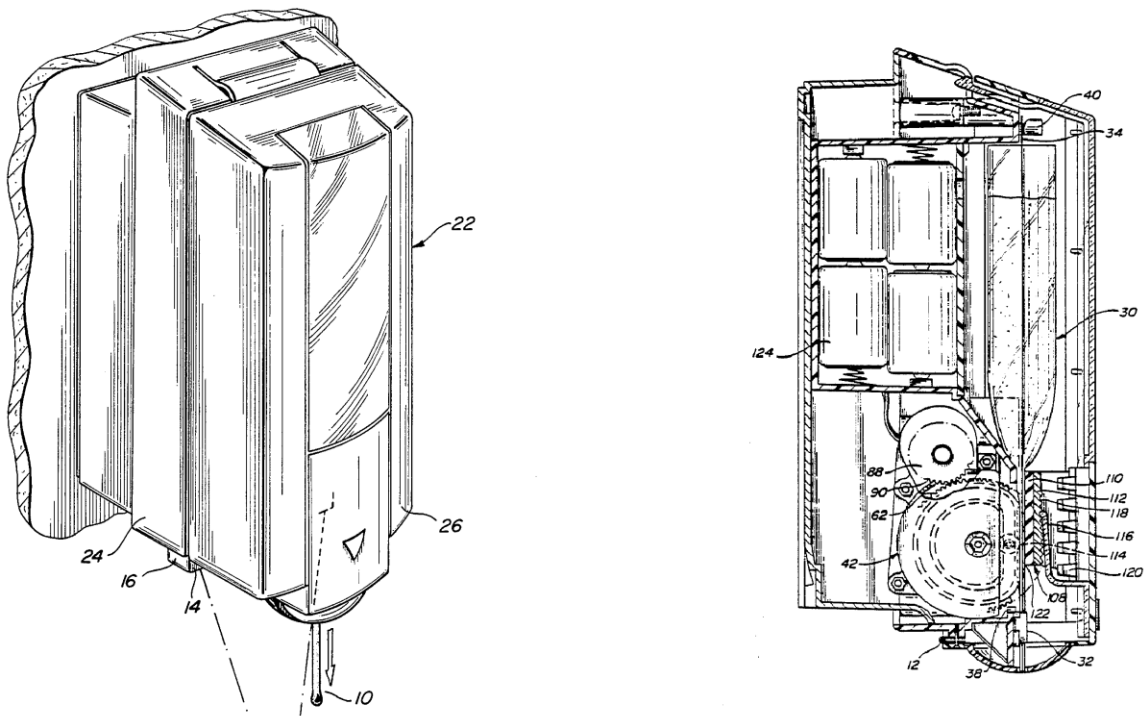

Figure 15 is surgical hand soap dispenser (Albert and Thomas [2]).

The device mentioned above works in a manner to only dispense a certain previously measured amount of the surgical scrub to the user without them needing to come into contact with the outside of the device or with the device in any manner. The device also doesn't allow any air to get into the soap supply. The use of electromagnetic energy directed right below the

nozzle for dispersal is used to view motion and signal the device itself to start its operations. The energy is in the form of infrared light and once an object or a human hand is within range below the nozzle the light is refracted off of the object and back towards the system and thusly the system is triggered. Once triggered the device starts by moving a roller over a dispensing hose of sorts and extrudes the soap out at the nozzle end once the pressure builds enough to overtake the force produced by the clip on the end portion of the nozzle (Albert and Thompson [2]).

The two devices described above as well as others of the same nature have the ability for the soap containers to be replaced once fully used or interchanged with a different type of soap specified by the areas in which they are used, such as schools will have a different soap then hospitals which will have a different soap then restrooms at a mall and so on.

### **2.6.2 Hand drying methods**

Today's hand drying methods range from a wide variety of different types of electric hand dryers to paper towels or towels in general, all dependent upon the location that the drying is taking place. Overall, they each have their flaws, some more than others, but there have been attempts made to improve on devices in this field.

There are roughly four or so types or classifications of hand drying methods that are in practice. These methods include paper towels and cotton towels, air hand dryer, the Dyson Airblade, as well as by evaporation. The electric hand dryers in use that do not include the Dyson Airblade are essentially just as dirty and unhygienic as anything because they recycle air from the restrooms without filtering it in any manner. This goes along with the problem of them being relatively slow for the most part and taking on average well over 30 seconds to fully dry a user's hands, and in general most people in today's world have too much of a faced paced life to wait for the full cycle to occur. Also, they are not the most energy efficient because the vast majority heats the air before they expel it onto the user's hands. But, an advantage to these particular

units is that they do not produce waste that fills up landfills, such as that produced by paper towels. An example of multiple different hand dryers is displayed in Figure 16 (Dyson [11]).



Figure 16 shows three different kinds of hot air hand dryers (Dyson [11]).

Some of these devices as shown above are more functional and more adept to our world today being faster and being motion sensitive so as to speed up the wash and dry cycle time and to eliminate the spread of germs from contact with surfaces. An example of the use of motion sensors can be seen in Figure 17 with the image of a hand dryer and automated sensor. This automated motion sensor allows the user to wave their hands below the blower vent of the hand dryer and for it to be triggered to start without coming into contact with the device at all. This is great because the spread of germs is cut off at one source, from people coming into contact with surfaces, especially after they would have just washed and sanitized their hands in the first process of the wash and dry cycle. Also, the infrared motion sensor helps to conserve energy by automatically shutting off the unit when the user's hands leave the field of view of the sensor (Dispensers [9]).



Figure 17 demonstrates motion sensors used on hand dryers (Dispensers [9]).

An advancement made in this field of technology can be found with the Dyson airblade system. This system utilizes Dyson's patented technology in order to peel away water from the user's hands as they remove them from the unit. This device uses motion sensors to trigger operation, as well as a timer to cut off the cycle in the appropriate amount of time specified by Dyson, which is roughly about 12 seconds (Dyson [11]). The device is an extremely efficient product both in cost and energy, being up to 80% more efficient than traditional warm air hand dryers and being up to 97% more cost effective than using paper towels (Dyson [11]).

Once triggering the device to turn on, a digital motor inside starts to work and spin at about 81,000 times a minute and moves the air through a heap filter which removes 99.9% of bacteria from the air, and then proceeds to force it out of two apertures at approximately 400mph (Dyson [11]). This device also utilizes anti-microbial additives that are used in the exterior surfaces of the unit itself. Dyson was also the first hand dryer ever to be approved for the food

industry by the HACCP. An example of the airblade, displaying the interior components as well as exterior components can be seen in Figure 18 (Dyson [11]).

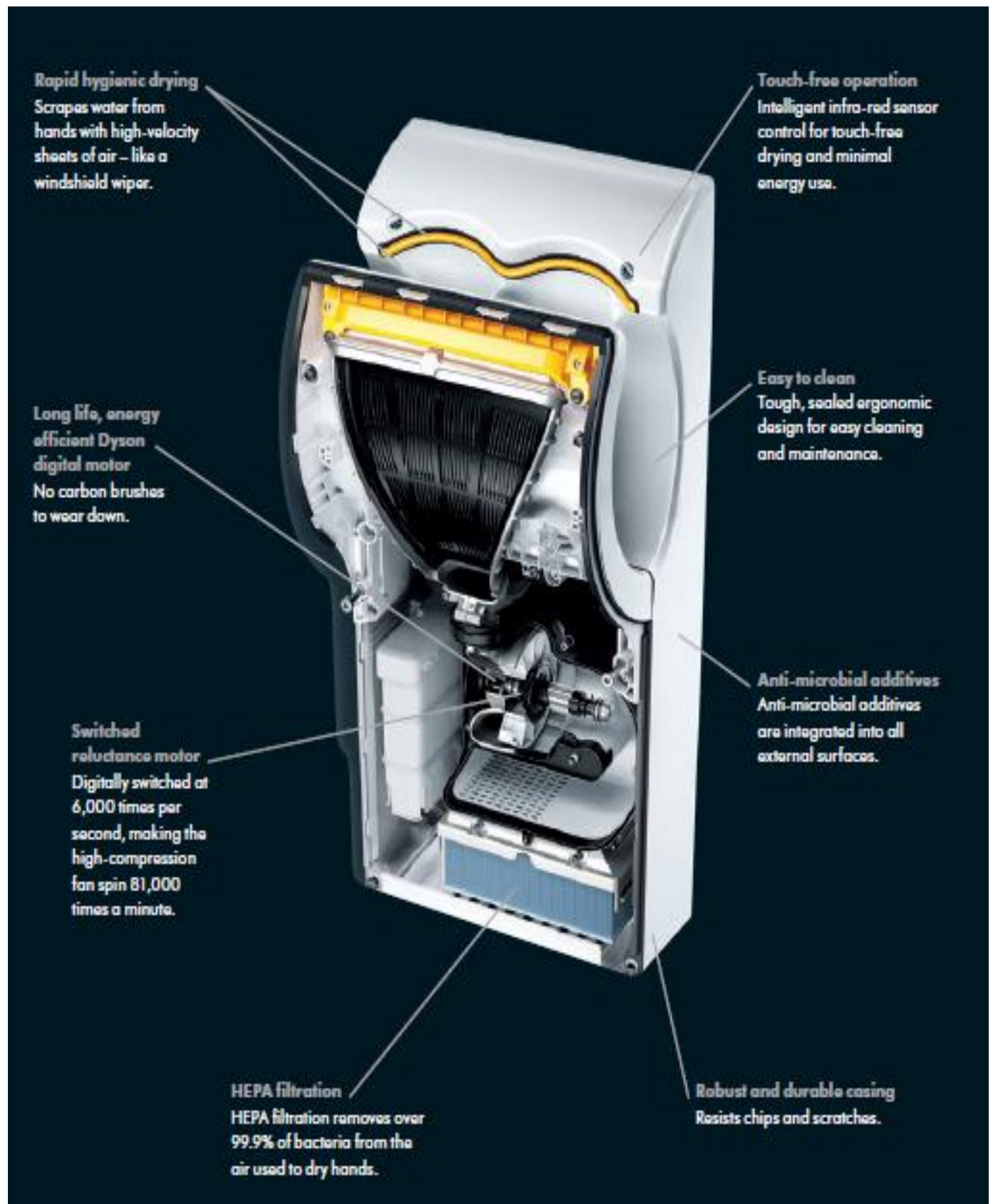

Figure 18 is a representation of the Dyson AirBlade and its interior components (Dyson [11]).

A much simpler method used for drying hands is to just use a regular cotton hand towel after you wash your hands in order to let it absorb the water and just be hung back up to dry. This in turn is much cheaper and relatively effective for drying hands. There are however some downfalls to this method too, just like all the methods, each have advantages and disadvantages. Some of these disadvantages include the ease of use and access in public areas such as malls, schools, hospitals, etc., as well as the increased capacity for this to collect and harvest germs, especially with multiple people handling the towels. Also with it being a constant damp area germs tend to multiply and spread to the next user much easier, and for the most part are only used in the household. This fact is that most people also would not want to use a towel in a public bathroom because not everyone shares the same standards as everyone else, and are much harder to be recycled through public bathrooms due to the need to be hung up to dry and to be constantly washed. The advantages to this method include the reusability of this particular product as well as the relatively cheap cost to use, and it can be washed and cleaned whenever is necessary. So, in other words the advantages of this method only out-weigh the disadvantages in one particular area of use, in the household.

Finally, another means of drying ones hands after washing them is to use paper towels. This is a much simpler and quicker method as well as more energy efficient in the eyes of the user. But, in reality this is not at all simpler, nor quicker, and definitely not more energy efficient given the statistics involved with production of this product. It is a known fact that many people take advantage of paper towels because of their ease of use and general convenience because you can use it for what you need and toss it away. This definitely goes along with the fast paced world we live in today because they are easy to obtain, are relatively cheap, and really convenient because you can use it and not have to do anything else to maintain it aside from restocking. However, all this using quickly and tossing away of paper towels

produces over 3,000 tons of waste per day. With that being said there are also many other disadvantages that are hidden behind the scenes of paper towel use because they involve production and transportation as well as trash removal (Depot [8]).

These disadvantages include the fact that in a restroom setting paper towels cannot be recycled really due to the fact that they get mixed in with other garbage and therefore are not allowed to be recycled due to the fact that they do not want to spread bacteria or contaminants associated with trash around recycled products. Also, transportation of paper towel products, the process of making them as well as packaging for these products are important factors in looking at long term disadvantages as well. The general cost of a single unit of paper towels is cheap but when they need to be replenished all the time the expense adds up in no time. Cost aside, these products have a huge environmental effect as well due to the fact that they are used for one job and tossed away. This process requires thousands of trees as well as thousands of gallons of gas to run the machinery in the plant that makes these and to use in the trucks that transport these. So, overall the disadvantages are numerous for this particular method and more or less outnumber the advantages, even though this method is still so widely used (Depot [8]).

### **2.6.2 Hand Sanitizer dispensers/ containers**

Today's hand sanitizers come in an extremely wide variety of containers and dispensers but together have the same functionality. These different means of storage and dispensing are what make this hand sanitation method so appealing to a people on the go and large public areas. Hand Sanitizers come in small containers that are easily portable and can even be attached to a bag for an increase in portability. They also come in larger containers and dispensers more suited for large offices, grocery stores, malls, schools, and any area in public essentially. The functionality of these containers and dispensers is immense and are definitely a factor in the popularity of this particular means of hand sanitation, especially in cold and flu seasons.



On the basic end of these containers there are simple bottles with pop open tops that store the sanitizer and when needed you are able to easily open the container and squeeze the desired amount into your hands. As the need for ease of use increases so does the engineering of the containers because some of the next level basic dispensing containers include a push pump which dispenses the product onto the users hands and only require minimal interaction with the pump top. The next level of similar function is a wall mounted unit which can be seen by Figure 19. This particular device dispenses sanitizer into the user's hands once they push the tab at the base of the device in. This device is essentially the same as previously mentioned soap dispensers but instead of containing they contain hand sanitizer instead.



**Figure 19 is a Purell pump hand sanitizer dispenser (Depot [8]).**

Then there are more technologically advanced dispensers which do not even need the user to come into contact with the device because they are completely automated and operate by use of simple motion sensors which trigger the device to dispense a predetermined amount of sanitizer onto the user's hands. The advantages to this particular dispensing container are the fact that there is no contact needed with it which means that there is also no direct spread of germs and bacteria through contact, and also that they are relatively inexpensive for the most part. This type of dispenser can be seen in Figure 20.



Figure 20 is a Purell motion sensitive hand sanitizer dispenser (Staples [23]).

These devices are extremely easy to use, easy to operate and maintain, and in general relatively cheap, which all together help make this a very widely popular means of hand sanitation.

### 2.6.3 UV sanitation devices

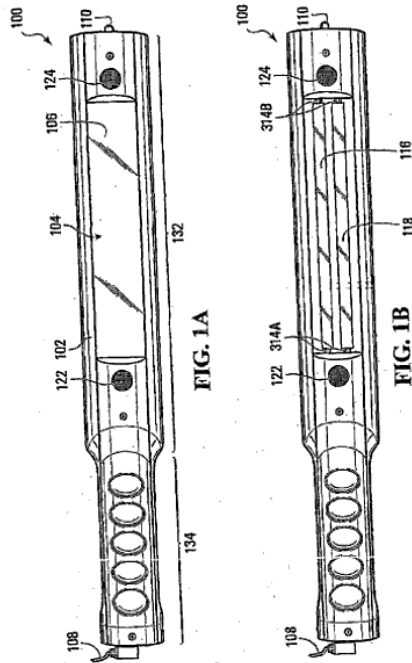

Figure 21 is a UV-C germicidal wand (Lyon [16]).

Figure 21 above is a UV-C germicidal wand. This wand is used to help eliminate bacteria and germs in different environments. The wand uses UV-C light to breakdown germs and bacteria at their molecular level by breaking down their DNA and rendering them unable to reproduce. This particular device allows the user to sterilize areas that they need sterile such as countertops, doorknobs, and essentially heavy traffic areas where contact is necessary. The wand can be run off of a battery pack once charged and contains a UV-C light bulb that is enclosed on the top side so radiation from the light doesn't affect the user. This allows it to be a portable bacteria destroyer with an increased functionality (Lyon [16]).

### 2.6.4 Current similar technology/ patents for washing hands

In the fields of Engineering and Technology there is always work being done in order to come up with the latest breakthrough or to better a product that predecessors developed. So, in order to truly figure out how to achieve the goal at hand for a replacement hand washing system,

research had to be done to find if there is already a product on the market that does the job or if there are similar products that can be looked into and learned from. The fact of the matter is that there are other devices that people have developed over the years in response to a similar goal, not the exact same, but same basic principles. So, with that knowledge in place a deeper look into the designs and functionality of other devices is necessary in order to view advantages and disadvantages to help develop constraints for the design soon to be modeled.

Figure 22 is a patented device has been established as a hand washing system that is slightly different from a traditional sink and hand dryer combination. This was developed to provide personnel with a way to recognize if they had finished the washing cycle process with audible and visual aids. These aids, both audible and visual, make it easier for someone to remember that there is a suggested length of time that should be spent washing and drying hands and hopefully would encourage better hand washing routines by your average user. This device also utilizes automatic functions so that the user does not need to do any additional work, and also does not have to come into contact with potentially bacteria infested areas, such as faucets and knobs (Davies [7]).

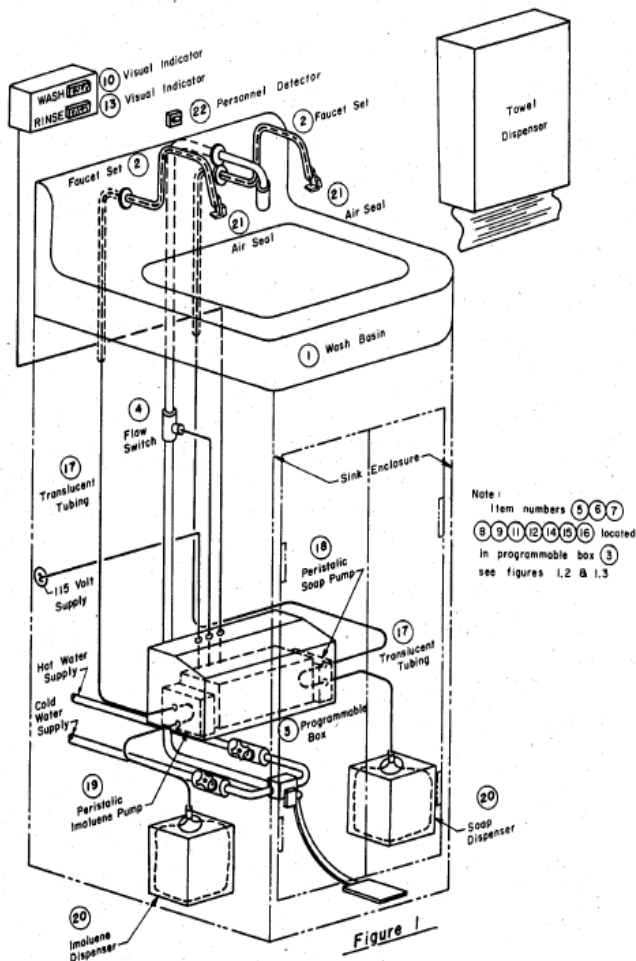

#### Equipment List

- |    |  |
|----|--|
| 1  | Wash Basin   |
| 2  | Faucet Set   |
| 3  | Programmable Control Box                                 |
| 4  | Flow Switch (normally open)                              |
| 5  | Line Fuse (120VAC)                                       |
| 6  | Step-down Transformer (120-24VAC)                        |
| 7  | Voltage Switch   |
| 8  | Programmable, two-cycle repeating timer (adjustable)     |
| 9  | Wash Timer (timed open timer, adjustable)                |
| 10 | Visual Indicator "Wash" Cycle                            |
| 11 | Soap Timer (timed open timer, adjustable) optional       |
| 12 | Rinse Timer (timed open timer, adjustable)               |
| 13 | Visual Indicator "Rinse" Cycle                           |
| 14 | Reset Timer (timed closed timer, adjustable)             |
| 15 | Audible (Buzzer) Indicator                               |
| 16 | Imoluene Timer (timed closed timer, adjustable) optional |
| 17 | Translucent Tubing (disposable type)                     |
| 18 | Soap Pump (optional)                                     |
| 19 | Imoluene Pump (optional)                                 |
| 20 | Soap, Imoluene Dispenser (disposable type)               |
| 21 | Air Seal (disposable type)                               |
| 22 | Personnel Detector (by customer)                         |
| 23 | Buzzer Timer (timed open timer, adjustable)              |
| 24 | Master Relay   |
| 8A | Nand Gate <u>Figure 4</u><br>(Multiple)                  |

Figure 22 is an automated sink (Davies [7]).

This article describes another patented design for a fully automated hand washing and drying device. Figure 23, would be suitable for use in areas such as hospitals, dental offices, and labs or other medical or science related buildings. The device functions in a manner which dispenses a cleaning solution on hands and then sprays them off with fresh water and finally dries the hands. This device has a very similar functionality to an automated car wash system where you pull your car in and it triggers the process to start and it applies the soap in one cycle comes back sprays off the vehicle in another cycle, and finally ends by drying the vehicle.

Some of the key features of the apparatus are that it is adaptable to different applications, it's in compliance with legal and social standards of cleanliness, inexpensive and easy to make, and is a closed system so no air or water will be directly diffused or splashed out. With all of these features this would be a great device for not only medical or science related settings but also in public restrooms, in restaurants or malls or even in schools. This device provides many options and has a wide range of functionality (Chardack [5]).

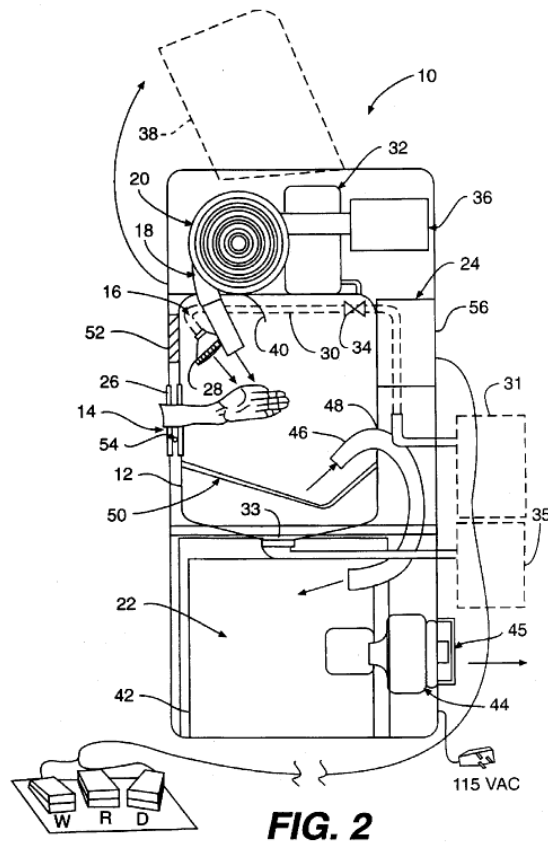

Figure 23 is a full washing drying station (Chardack [5]).

Figure 24 is another similar patented design to the previously stated device. This device has a similar goal and similar basic underlying principles in its development but is a much smaller unit and does not have as much functionality as Figure 23 due to the lack of adaptability of the device. The purpose of this device is to be an automatic hand washing and drying apparatus with a simple and straightforward design. The device utilizes multiple ports for water, air and solution injection above a basin where the user would insert their hands. It also contains a motion sensor on the inside of the device to detect when hands enter into the system and a timing system to help keep a cycle going for the hand washing and drying (Stanley E. Flowers [22]).

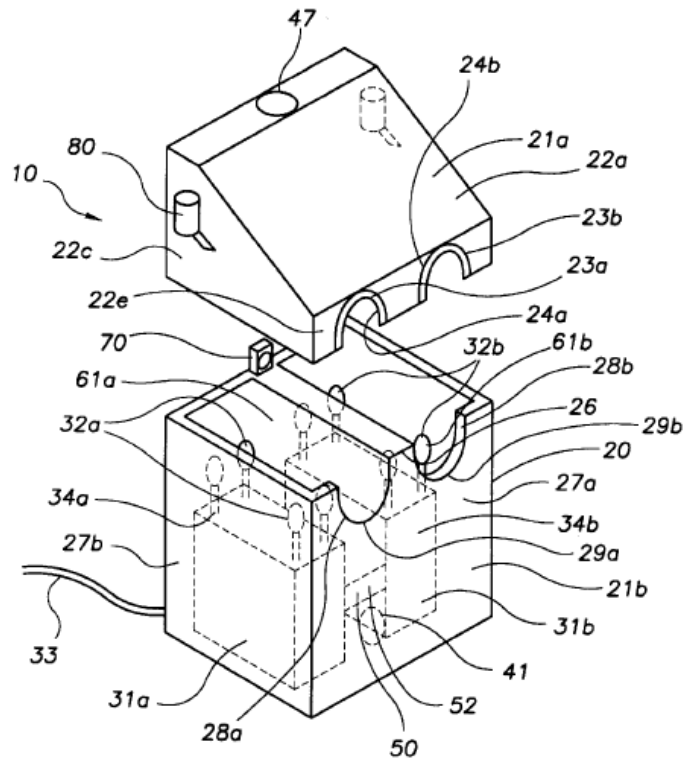

Figure 24 is another hand washing station (Stanley E. Flowers [22]).

Figure 25 is another rendition of a patented hand washing station. This apparatus utilizes a wall mounted cabinet, a proximity sensor and processing circuitry. The cabinet contains the soap dispenser as well as the water lines and the circuitry controls for the dispensing of the soap and water onto the hands which are sensed by the motion sensor. This system is also designed to keep track of hand washing counts and has the ability to be downloaded for analysis. This systems primary goal is to be able to provide data regarding hand washing activity more so than to have full functionality of an automatic hand washing device as seen in previous devices. This model however provides much more of an in depth look into the circuitry then any of the previous patents due to the nature of its intentions (Foster [14]).



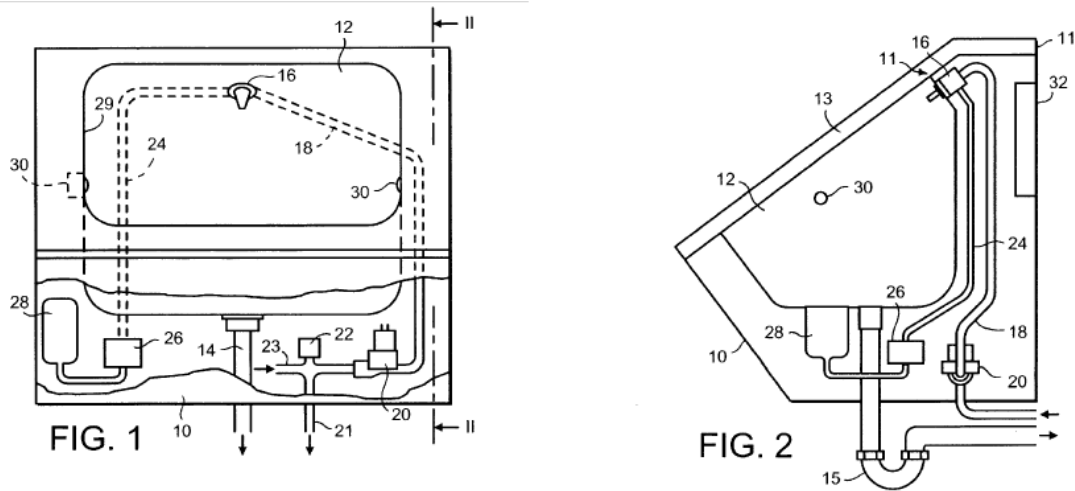

Figure 25 is an automatic sink (Foster [14]).

## 2.7 Current technology on Filtration systems

The need for a way to minimize the use of water as well as make sure the water we are cleaning our hands with is semi clean prior to use is vital to this project. In order to achieve this there must be a way to filter the water prior to use in the system as well as to filter water after use in the system. It is vital to have clean water prior to use because if it were contaminated or dirty it would counteract the entire purpose for washing hands in the first place, and it is also vital to filter after use because there's a need in the world to reduce the use of water and one way to do that is to recycle water by means of filtering it. A couple of examples of filtration systems are shown and described in the following section.

Figure 26 is a patented filter design used in household systems for the filtration of the water. This filter utilizes nine different filter elements ranging from coarse filter fabrics that trap bigger debris to finer filters that trap small debris, and going through even more with carbon filters to remove some of the smallest impurities. This filter would be used to help recycle some of the waste water from the system after a normal hand wash has taken place. The drain would lead the water into this filter and the filter would remove dirt and grime as well as impurities

in the water such as the remains of the soap or solution that had been washed off. It will also be important for us to introduce fresh water into the system from time to time to replace any that has gone missing from wash cycles (Thellmann [24]).

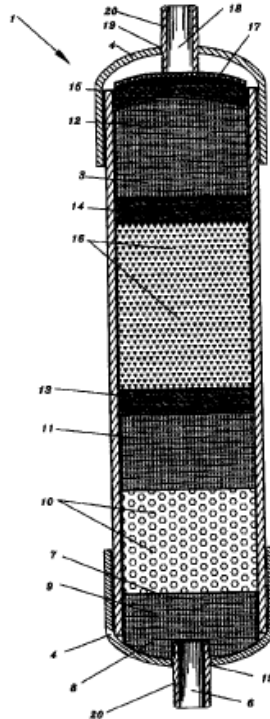

Figure 26 is a typical household water filter layout (Thellmann [24]).

Figure 27 is a great example of the type of filtration system that can be utilized by our project because it has a similar function. This system is used in automated car washes to filter out the water that drains into the trenches after every car wash. This system is great because our device is going to be very similar to a car wash except on a smaller scale and for your hands. The filtration system above utilizes trench drains to collect the water that needs to be filtered. From there the water goes through multiple processes such as coarse strainers and fine strainers and into finer filtration means of centrifugal separators. This level of filtration is great because

it's expedited because it is pumped through the process and also separates out more of what we need it to separate, grime, soaps, etc. (Ennis & Chelton [12]).

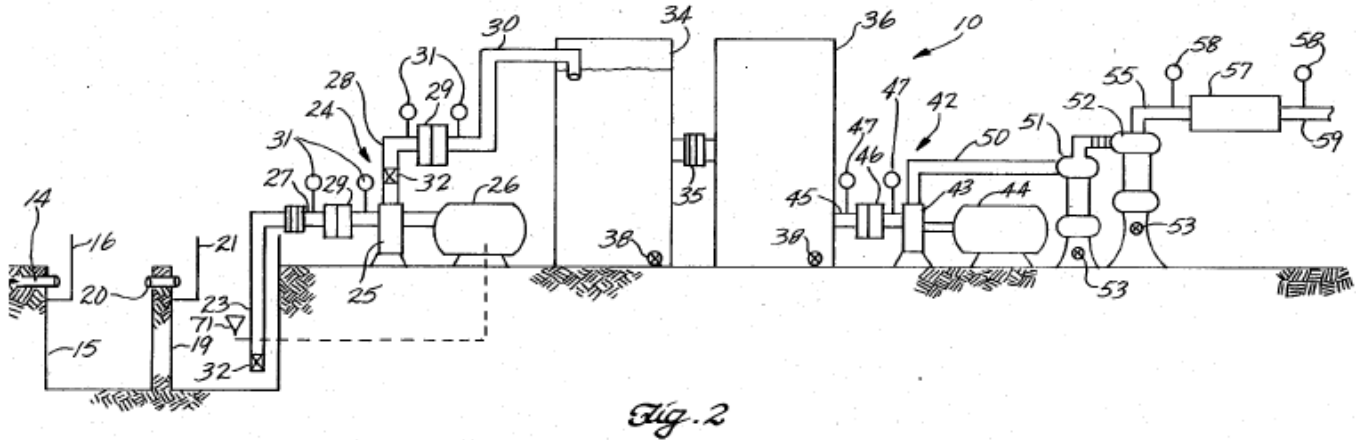

Figure 27 is the filtration system for automatic car washes (Ennis & Chelton [12]).

## 2.7 Sustainability

The main issue with today's American hand-washing techniques is many people take advantage of the seemingly unlimited water supply in restrooms. Many mechanisms have been invented in order to try to discourage the use of too many paper towels such as remote activated dispersal of a set length of towel to use, or pre-cut pieces. The problem with this is that people are able to just reactivate the sensors and obtain more and more paper. The idea of using pre-existing sanitizing techniques, often utilized in hospital settings came to mind when confronted by the issue with water and paper towel waste.

## Chapter 3 - Designs

### 3.1 Problem Statement

According to the Centers of Disease Control (CDC) washing your hands is the most effective and number one way to prevent the spread of germs (CDC, [4]). Improving hand hygiene is a challenge because even though guidelines are provided society's compliance is substandard. Today, most all healthcare settings have hand hygiene guidelines but multiple studies have shown that the majority of healthcare works do not follow them (Rybicki [19]). These two statements lead us to our design objective. We believe that compliance is inadequate because washing hands often takes time away from the worlds fast pace, busy schedule.

Our design project goal is to design an improved faster way to wash hands. The device needs to be easy for any person to use and comparable to the gold standard, washing hands with soap and water. Ideally this technology will get rid of grime, kill germs, and dry hands all in less than 15 seconds. The optimal design will use minimal energy and filtered water for sustainability, as well as decrease usage costs. Finally the device will have a cost comparable to current public facilities and be safe for all users.

In our project we acknowledge that hand sanitizers, and alcohol hand rubs are recommended because they have a large antimicrobial spectrum, they can be spread easily over the hands, they evaporate rapidly, and there is no need for sinks or hand dryers. We agree they are useful but we also feel that hand washing the gold standard for a reason. Companies are trying to produce better and more effective soaps and sanitizers. We, as a design team, want to improve the user interface for hand washing. If we can make hand washing energy efficient, water saving, long lasting, cost effective, and with a comparable time frame as other methods, we can still keep the gold standard, more effective way to wash hands.

## 3.2 Design Objectives

The objectives of the project are the operational steps, measurable quantities, and specifics that fulfill the Project Statement. Our list of objectives includes a device that:

- Completes full washing and drying hand cycle under 12 seconds
- Comparable to the gold standard: traditional sink, soap, and paper towel
- Energy Saving Components
- Sustainability- uses and wastes little water
- Safe
- Used by all ages
- Used by all different hand sizes
- Same or cheaper cost traditions methods (sink, soap, towels, dispensers)
- High Volume capabilities
- Easy maintainable and fixable
- Easy waste disposal
- Durable
- Easy to operate for user
- Cleans off grime

### 3.3 Design Constraints

The constraints of the project are the restrictions within the project. The specific part of the project that MUST be complete and/or MUST meet the design specifications or the project FAILS. The team's constraints include:

- Safe
- Ease of Use
- High Volume Capabilities
- Complete cycle under 12 seconds
- Sustainability of Energy and water
- Budget comparable to current gold standard (sink, soap, towels, dispensers)

### 3.4 Objectives & Constraints Tree

Constraints are parts of the project that the design **MUST** meet. Objectives are the goals of the project.

Red Ovals = Objectives

Blue Rectangles = Constraints

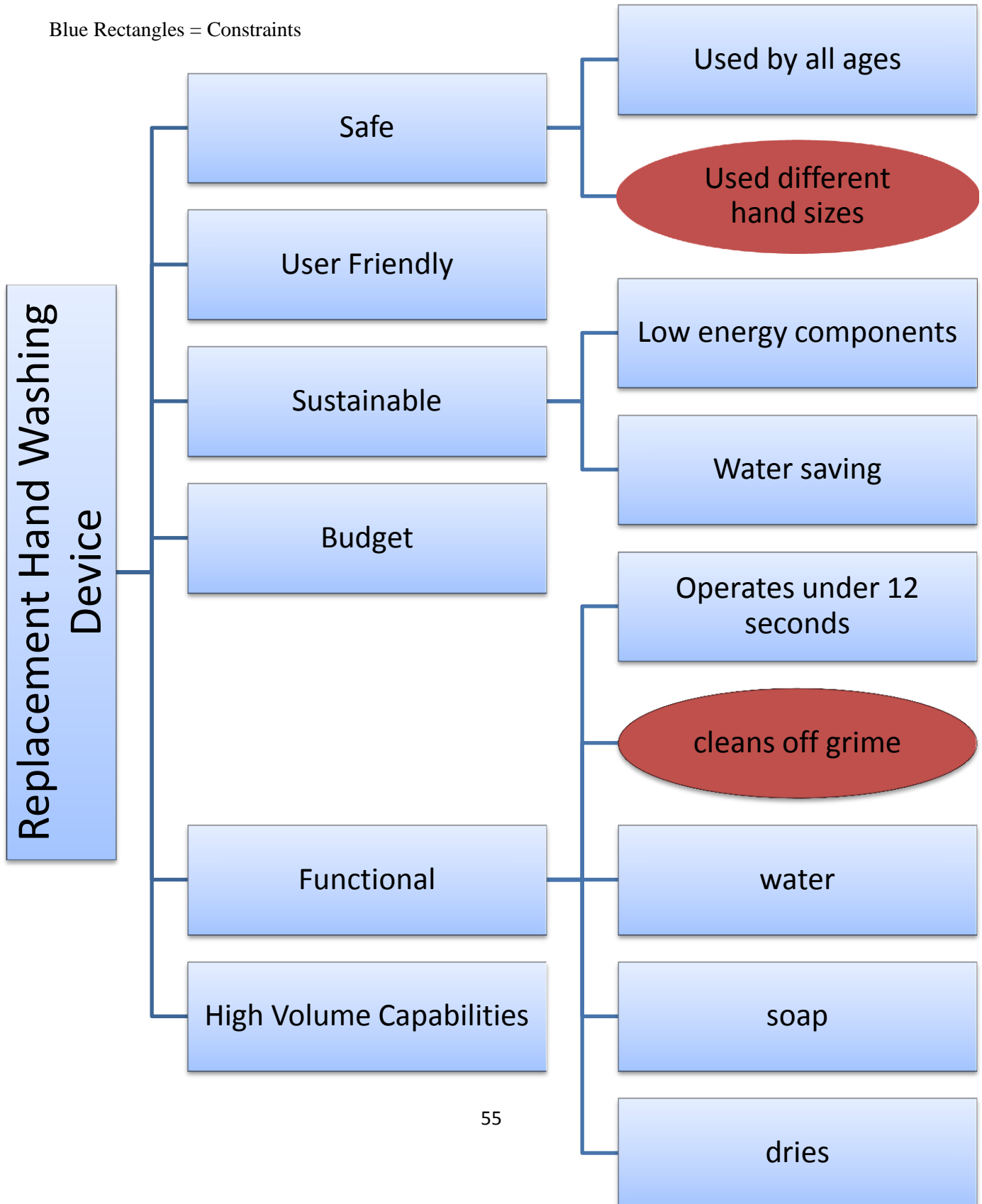

### 3.5 Design Flow Chart

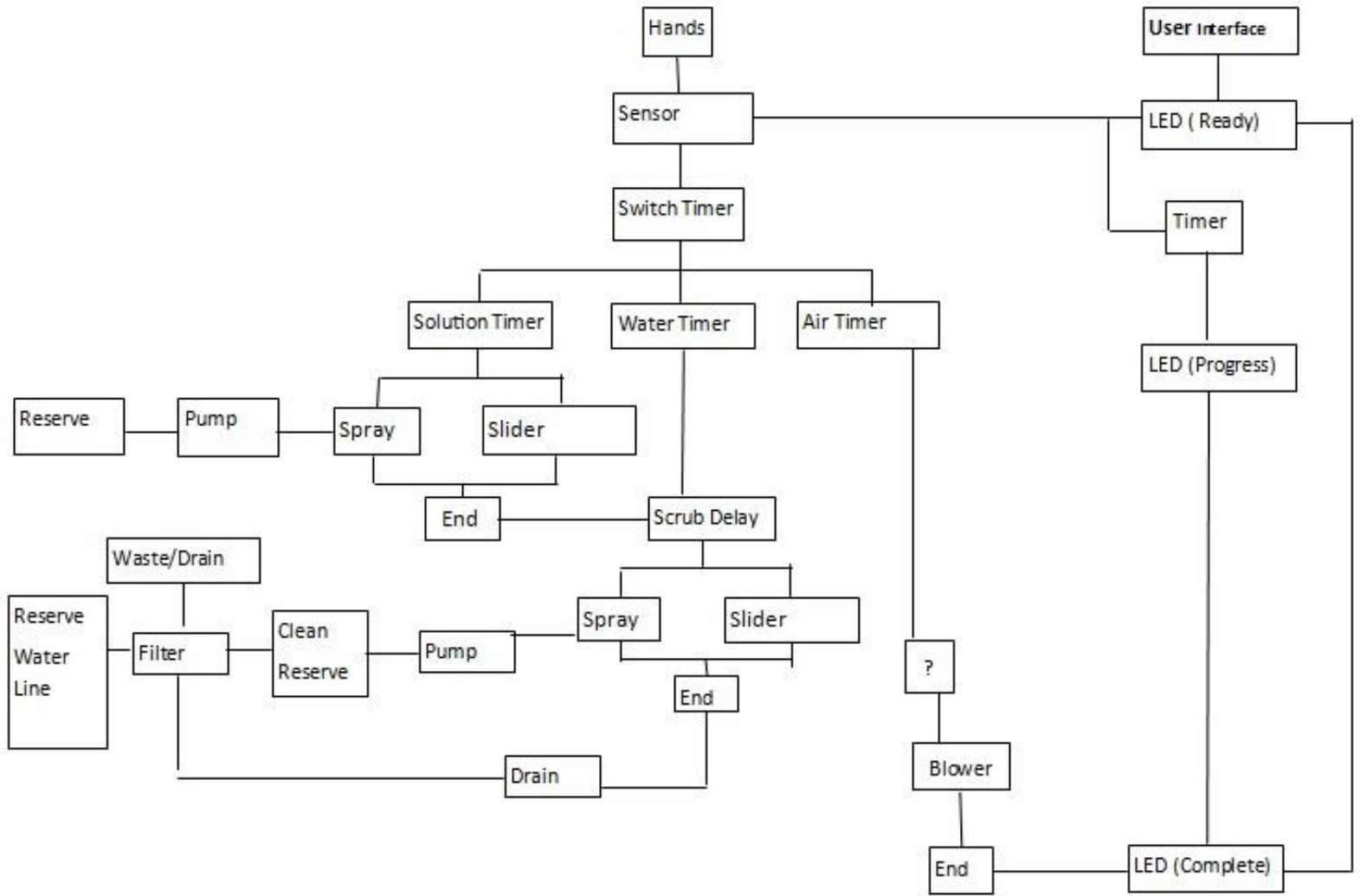

The flow Chart shows the basic design components necessary for the device. It also allows us to plan accordingly on how to put the device together and research different components. To preform our project each team member was able to take 2-3 components to research. We compared multiple components together and then choose the ones that best fit our needs. The details can be found in section 3.7.1 Final Design Components.



### 3.6 Design Alternatives

#### 3.6.1 Selection Sanitation Method: Soap, Hand Sanitizer, UV Sanitation

Our goal is to replace standard sinks, hand dryers, and soap dispensers in public bathrooms with our hand washing device. The best sanitation method for the design is with the use of traditional soap. Soap gives the ability to clean off grime and is the safest. Soap compares just as well to hand sanitizers and is still the gold standard today. Table 6 compares current hand washing methods.

Table 6 compares the current methods to different desired objectives. 1 is the most effective rating and 10 is the least effective.

Methods/ Objectives	Safety	Ability Kill Germs	Cost	Availability	Water Usage	Energy Usage	Clean Grime	Totals
UV Sanitation	8	3	5	4	1	7	9	37
Soap	3	7	3	3	5	4	2	27
Hand Sanitizers	4	5	3	3	1	2	8	26

### 3.6.2 Alternatives

Figure 28 displays the first of the design alternatives. The figure displays the designs exterior components and overall design.

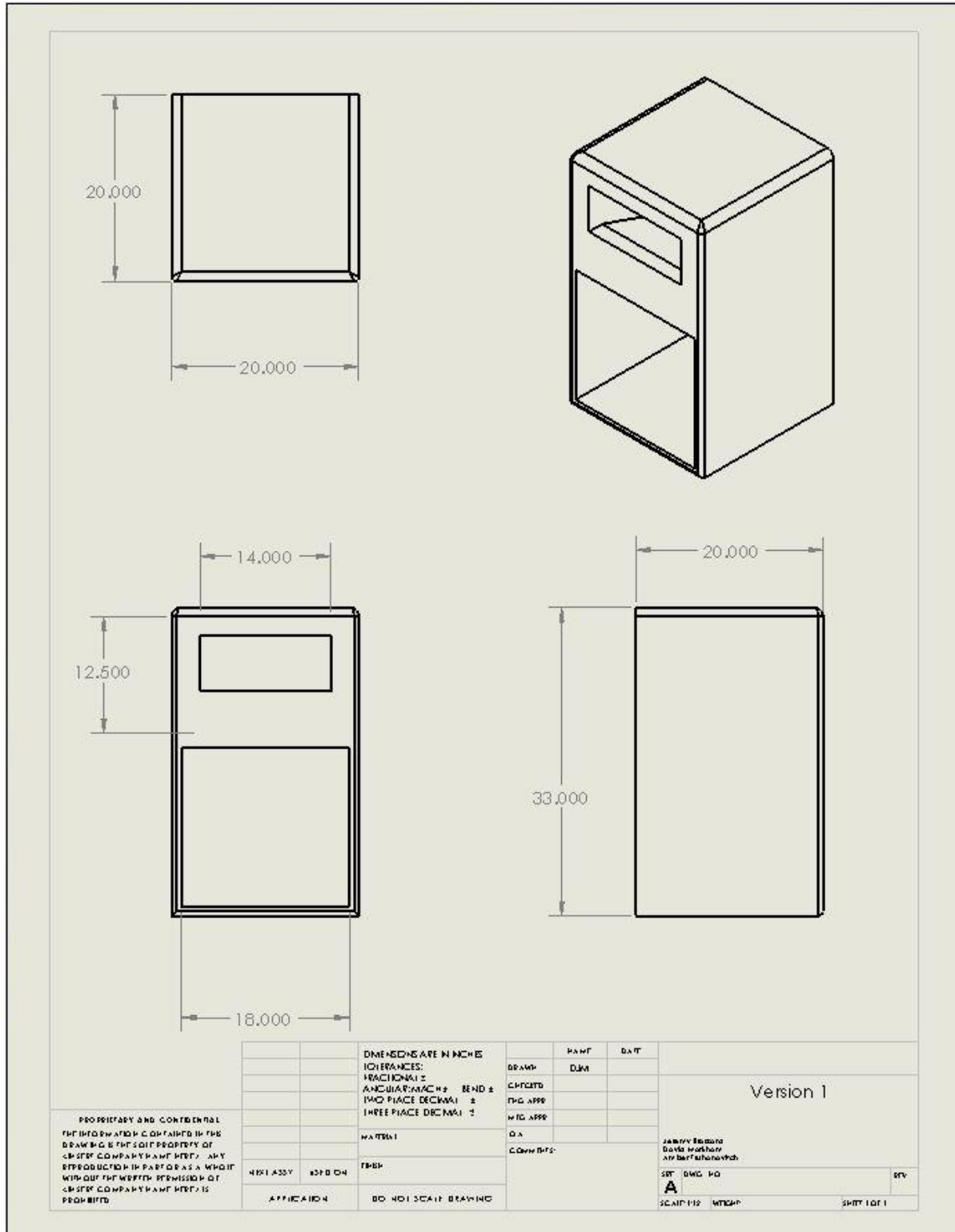

Figure 28: Solidworks model of Design Alternative 1

The intended device will operate in such a manner where the user inserts their hands and triggers a motion sensor inside. Upon being triggered the solution jets starts spraying solution onto the user's hands starting at the palm by the wrist and moving on a slider track mechanism in order to spray all the way up to the fingertips of the user. The solution jets will fully encompass the inlet of the device allowing it to spray from all sides. After the solution jets run there cycle for approximately 2 seconds, there is a minor delay allowing the user to rub their hands together in order to get any grime off. After the delay the water jets will start spraying and move along the same slider mechanism as the solution jets but this time ending the cycle in about 5 seconds. Once the water jets stop the air jets will turn on and the user can slowly remove their hands sliding them past the air apertures which should remove any water from the user's hands. This will be supplied by air taken in from the outside through a vent located on the top of the device and it will pass through a filter prior to being forced out through the air ducts to the apertures at the end. The blower and motor will be located somewhere near the back middle section of the device. There will also be a trench type drain used to collect all the waste material created during the use of the device.

Figure 29 displays the second design alternative. This design is very much the same as the first design except that it is set up for the user to insert their hands into separate hand holes without the ability to touch their hands together.

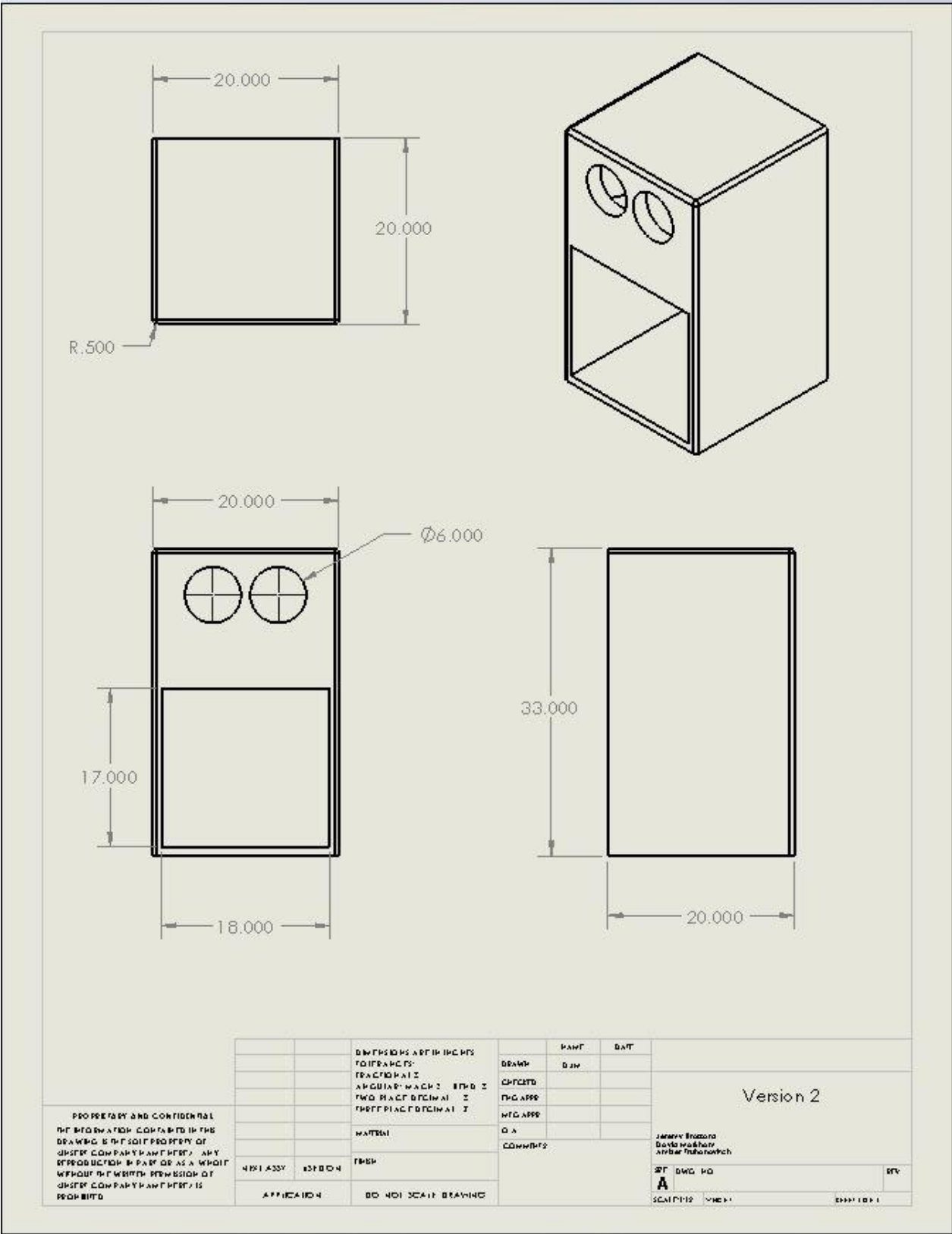

Figure 29: Solidworks model of Design Alternative 2

Aside from the difference the device will maintain the same interior components and function in the same exact manner as design 1 minus the pause for the user to rub their hands together to help remove grime.

A third alternative can be seen in Figure 30. It is the same basic exterior concept as alternative 1 but the interior components are much different. Inside of this device the components are drastically changed to address the change of technology. This third alternative utilizes UV-C light to sanitize the users hands so there will be no waste and much less energy used. Since there are much fewer components involved in this design the lower portion of the device can be used as storage for items such as spare bulbs or screws or even the cleaning supplies for the bathroom.

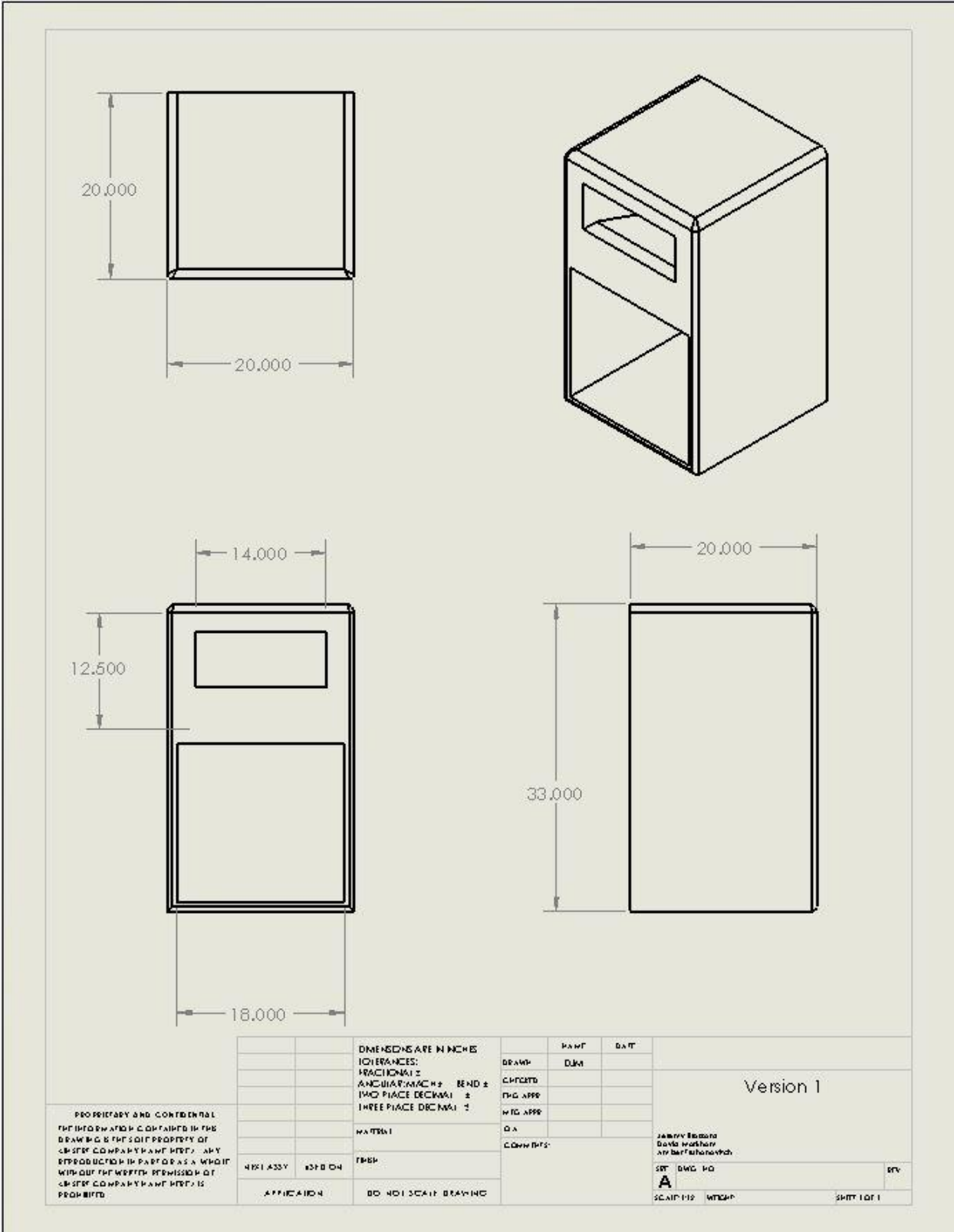
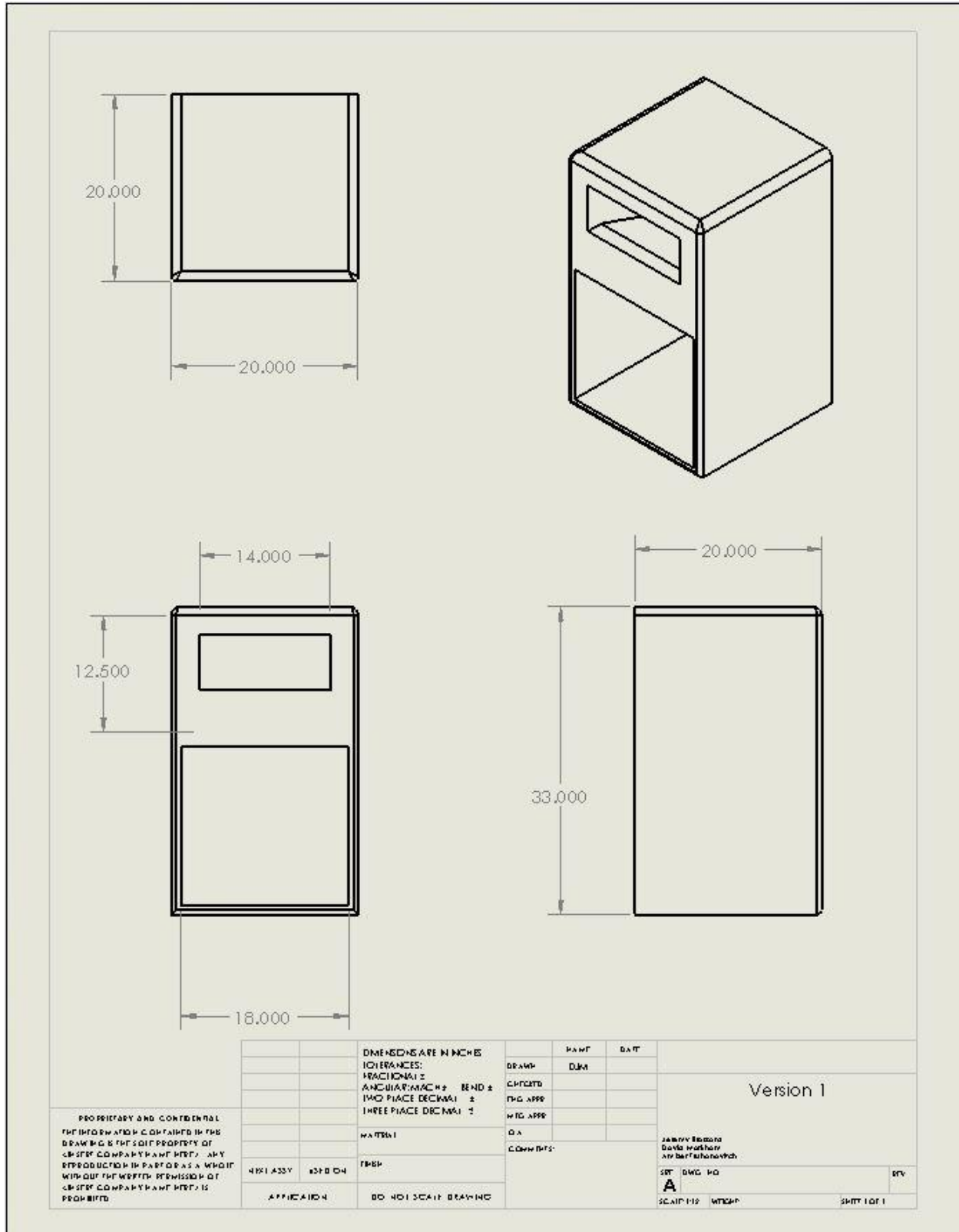

Figure 30: SolidWorks model of Design Alternative 3.

### 3.7 Final Design Components

The final design concept is similar to Alternative 1 but with dimension alterations. This can be seen in the SolidWorks model below.



### 3.7.1 Final Solution

The solution that will be contained within our hand washing mechanism will be regular hand soap, since that is what proved to be the best choice when compared across the board on our graph in Chapter 2. A common liquid soap, such as Kess Pearldrop liquid hand soap, would work ideally. It can be obtained in gallon-sized increments (ReStockIt.com 2009) which could then be poured into the reserve for soap inside the hand washing mechanism. The cost of this would be about \$25.00 after shipping and tax, and a discount could be had if bought in bulk. This would be just one example of a liquid hand soap and cost that could be used. Further investigation into bulk discounts and costs from manufacturers would need to be analyzed to obtain the best deal though.



*Figure 31 is a picture of the Pearl Drop liquid hand soap. It is a possible soap solution that could go into the machine. (ReStockIt.com 2009)*



Another liquid wash that could be used inside the hand washing mechanism would be the NDP solution. No price is given, however it can be bought in 1 liter increments according to the Vesimin website (NDP Derm+ 2011). This type of washing solution would work much better in immediate sanitation and post-washing sanitation since some of its properties continue to work over a couple hours after use. Between these two solutions, the main sanitizer being used would be the liquid hand soap since it is cost effective and functions well as a sanitizer.



Figure 32 is a picture of the NDP Derm+ solution that could potentially be used inside the machine. (NDP Derm+ 2011)

### 3.7.2 Final Solution System

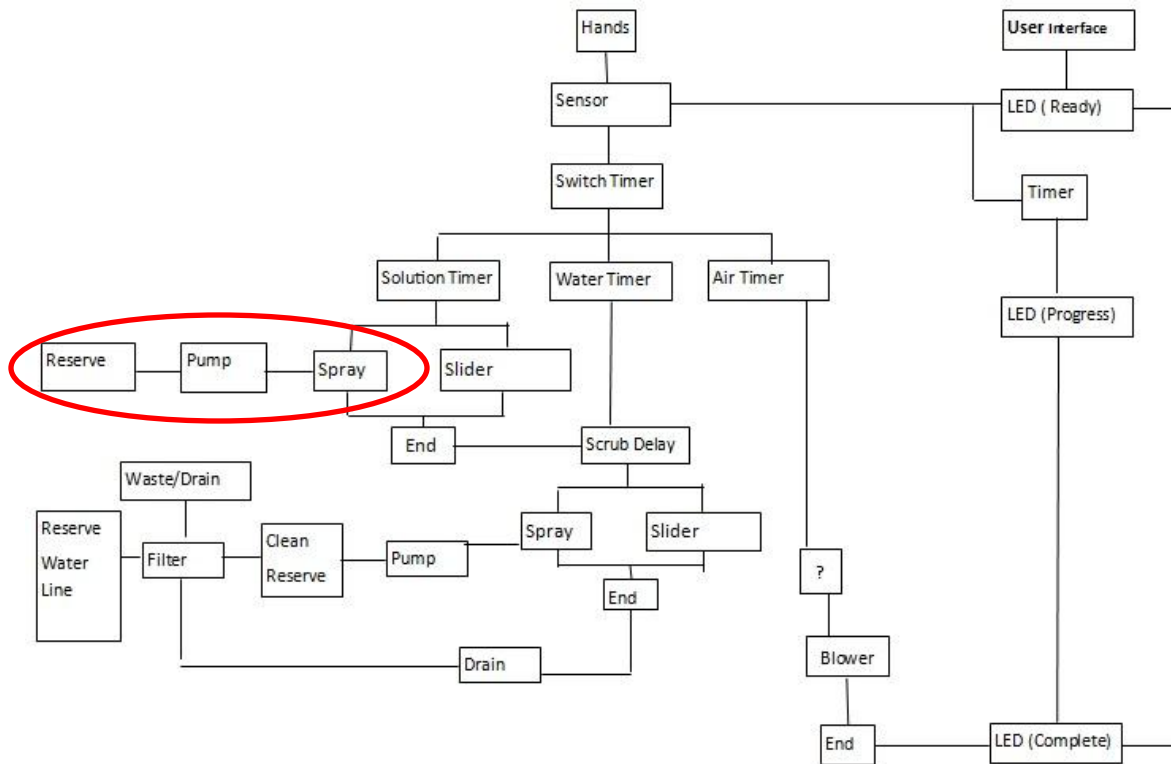

When it came to determining an appropriate dispersal system for the soap solution multiple ideas were developed. One of these ideas was based on constructing a custom sprayer nozzle that would completely encircle both hands and spray from all directions directly at the hands. Originally this seemed like a great idea until it came down to a couple of key factors involved with it, regulating a specific amount sprayed, how to get it to spray out, how to actually create the nozzle apertures for the liquid to be sprayed out as well as several other factors including chose of material and sizing of materials needed. This idea was considered but pushed to the side in hopes of finding a device that is currently produced that had many of these factors already addressed and incorporated in the design.

Another idea that was generated was to just use the same spraying system as the water and to basically just have them turn on at separate times and have an internal switch to alternate between the two inlet pipes. This too seemed like a great idea at first because it would save

material and definitely be more cost effective to device as a whole. But, like the other idea a few problems were determined as the idea was developed and brainstormed upon. Some of these problems were the fact that the soap solution shouldn't be pumped out at the same rate as the water because for one there is no need for nearly as much soap as water. Also, in order to actually achieve this idea there would need to be a control system put into place in order to regulate the flow of water or soap solution and shut off valves to ensure the two wouldn't mix or else there would be problems with the system. Overall it just seemed to have more possibilities of possible problems than necessary and again was put on the back burner so to speak and other ideas would be brought forth to be addressed.

After a few more ideas were played around with one that really seemed to stick was the idea of using something that is already readily available but not necessarily thought of when someone thinks of a soap dispenser or sprayer. The device being referenced here is the windshield washer sprayer system that is currently used in vehicles today. Although it is not something that one would make a direct connection to sanitation in the first place its functionality for this device is impeccable. The whole system, which includes the liquid storage container, pump(s), hoses, and sprayer heads, can be purchased together and in some cases some include two pumps which here would be extremely beneficial since we have two separate areas to be pumped to for the dispersal of sanitizing soaps. An image of the whole system can be seen in Figure 33.



Figure 33 shows the electric windshield washing system that can be implemented for the solution.

An image of the tank with dual pumps which was chosen for use in this mechanism can also be seen above in Figure 34 as well. The storage tank itself can be a range of sizes depending on the size constraints of the device but in general a 7 liter tank would be used. With this setup one pump will operate the sprayers on the top of the mechanism and the other pump will operate the sprayers on the bottom of the mechanism. The individual sprayer heads will then be attached to the water sprayer mechanism and have flexible hoses, which will be able to move with the motion of the slider device chosen, which run directly to their corresponding pumps attached directly to the solution storage tank. This system would be able to be linked into our timer and be able to spray directly at the users hands at a descent rate while still being able to conserve the amount of soap solution used.

A Solidworks 2-D dimensioned drawing of the sprayer nozzle head can be seen in Figure 34.

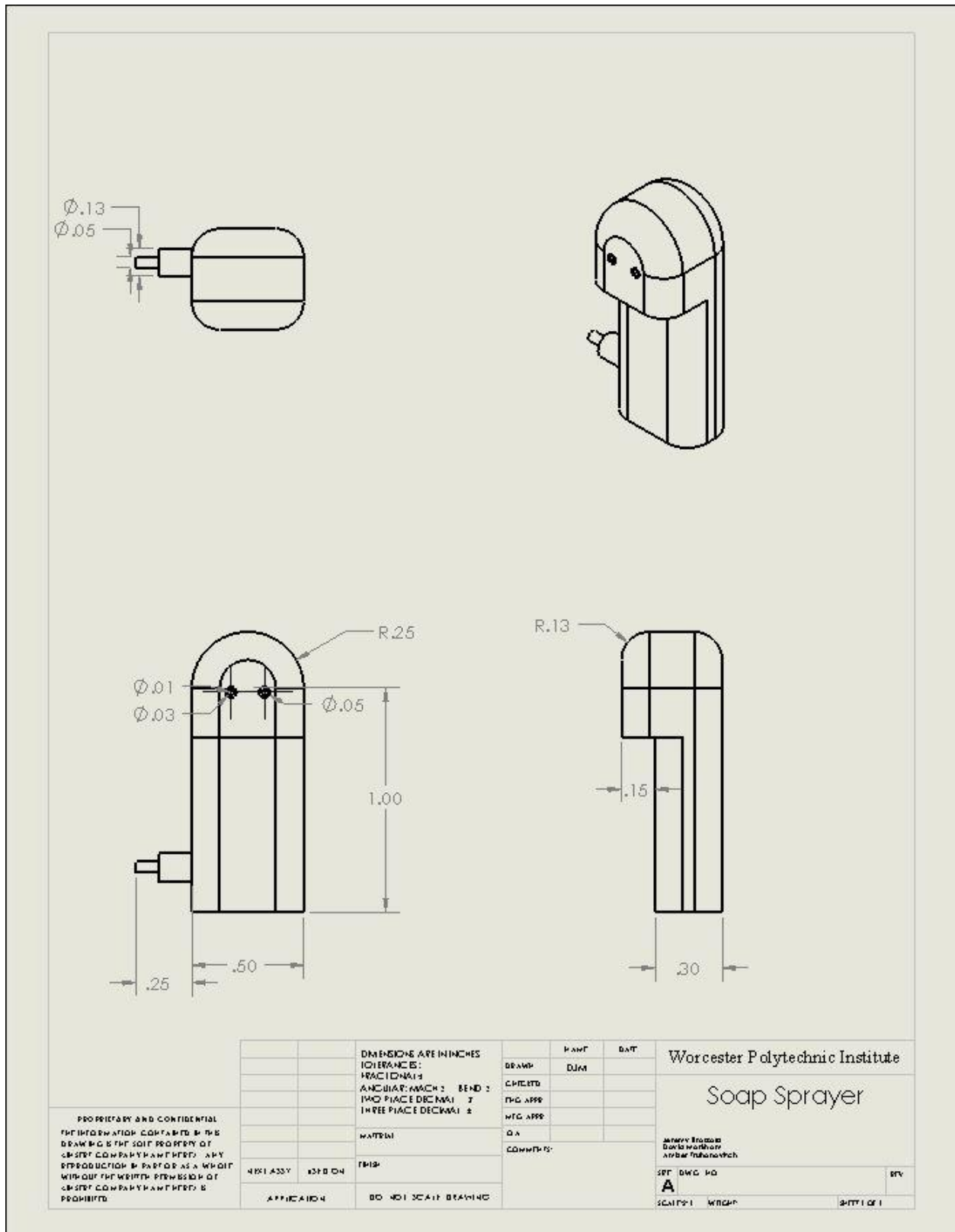
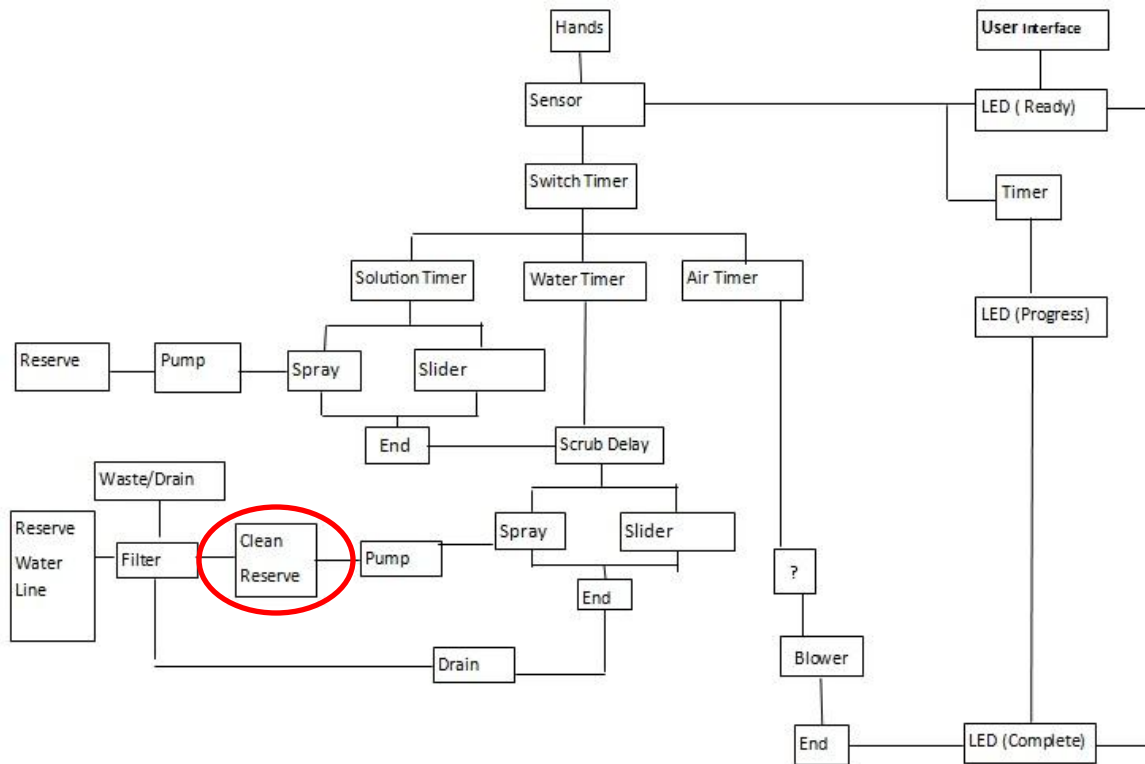

Figure 34 is a SolidWorks model of the soap sprayer nozzle.

### 3.7.3 Final Water Reserve



Having a reserve to hold the water is necessary inside a device like this. The volume the tank holds and the specs on its dimensions are the deciding factors on which one to use. A simple water storage tank would be the cheapest way of getting a tank to put in the mechanism, and it can be made of plastic as well, so if any of it needs to be cut in order to fit the pump inside, it can be done easier. There are no defining characteristics about the water going inside being chemical in nature, corrosive, or contains radiation so a simple water tank can be used.

When deciding on which size to pick for the reserve, one must factor in several variables. First would be how much water will be used up in each spray. According to the National Plumbing Codes in public locations the acceptable flow rate of water is 0.5 gallons per minute which is commonly controlled by aerators. This is an important feature to know so one can keep a good amount of water available so the reserve won't need to be refilled as frequently. Another variable that can be grouped with the first one is how much traffic this mechanism will be getting

per day. This, again, is important to know in order to reduce refills. Another variable would be the dimensions it can be made into. This could be important if a custom fit is needed to fit it inside the machine. Lastly, one would need to know if the pump can be manipulated easily in order to fit a pump onto/into it so it can actually be used. Thinking of these variables first, and picking the reserve second is beneficial in saving time before putting all the machines parts together so one knows if they will fit nicely or not.

The tank style that was decided upon is Part number A-SP0006-5N, a simple 6 gallon water storage tank made of polyethylene and has UV inhibitors from Flat Bottom Utility Tanks. Its dimensions are 12" length x 15" width x 8" height and costs about \$37.99 online before taxes and shipping.

© DEN HARTOG INDUSTRIES, INC.  
 Copyright. All information furnished within this document, electronic file or design correspondence is the property of Den Hartog Industries, Inc. and shall not be used, disclosed to others or copied without the expressed written consent of Den Hartog Industries, Inc.

SP0006-5N

A

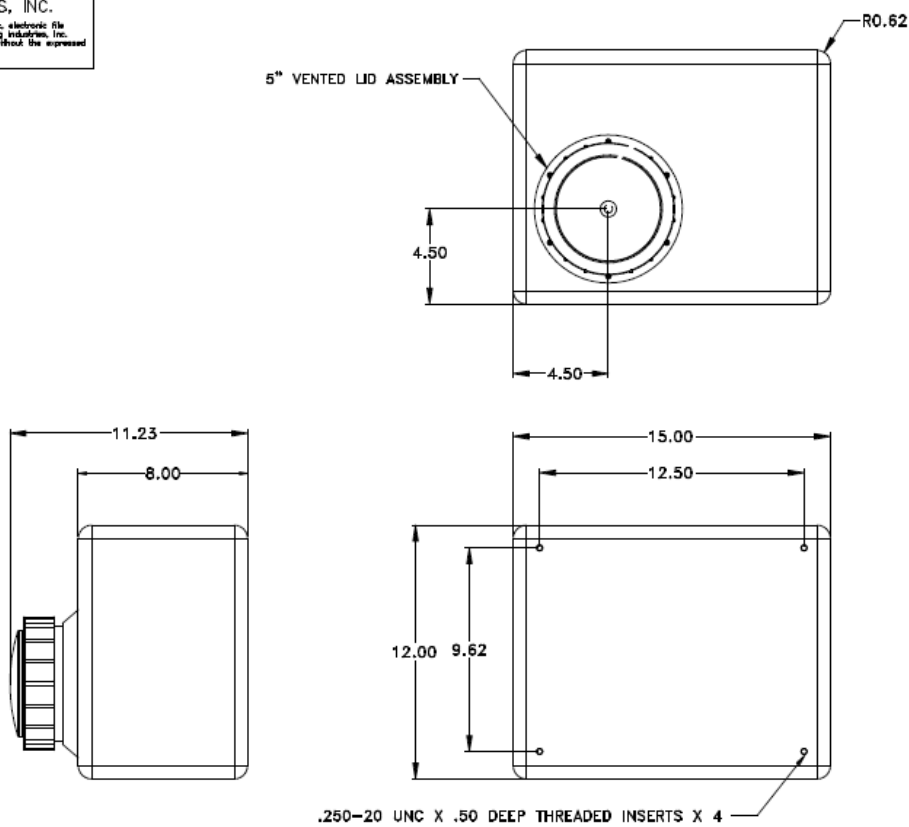

.250-20 UNC X .50 DEEP THREADED INSERTS X 4

			DRAWN / DATE DHJ / 7/26/01		MATERIAL	
			APPRD. / DATE REH / 7/26/01		@ 5 LB. MOBIL 134	
A	SHOT WEIGHT CORRECTED	CON 1802	2/16/09	ADH	 <b>Den Hartog</b> INDUSTRIES, INC. <small>Acc Role-Mold Injection Molding Blow Molding Surfing</small> 4010 HOSPERS DRIVE S. BOX 425, HOSPERS, IOWA 51238-0421	
REV	DESCRIPTION	DATE	APPRD	CLIENT / DESCRIPTION 6 GAL. SPECIALTY TANK		
ALL DIMENSIONS ARE IN DECIMAL INCHES TOLERANCES UNLESS OTHERWISE SPECIFIED $\pm 1\% @ 68^{\circ} F$				THIRD ANGLE PROJECTION ANSI 14.5M 		NOTES: 1. NATURAL COLOR 2. NOM. WALL .150
				SCALE	N.S.	PART NO. SP0006-5N

Figure 35 is a picture of the dimensions of the storage tank. (Flat Bottom Utility Tanks 2011)

The storage tank also has a 5” vented lid, which can be utilized to fit the pump and a possible entrance port for water from the indoor plumbing in certain facilities. If need be, the plastic should be easily cut to fit the pump inside, and then sealed shut to prevent any leaks. The size of the tanks should also be small to fit inside the machine without any difficulty. For the water the machine will be hooked up to water lines similar to traditional sinks. We will use the lines and a “reserve sump pump” to keep the water reserve full. Water reserve will function in the following manner. First it will start of full prior to the first user using the device as users begin to use the device water level will slowly begin to fall, but as it falls it will be slowed down

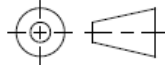

due to the use of the a filtering system which will filter the used water and send the good water back to the reserve tank while discarding any other impurities from the used water. This will help to keep the water level steadier in the reserve but because not all of the water used will be returned to the system there will be an electronic water level sensor installed in the reserve which will be triggered upon near depletion of the water in the reserve. When this finally occurs the sensor will trip a solenoid operated diaphragm valve and cause it to initiate the flow of water from the original water line of the building. Upon filling to the designated amount the sensor will tell the solenoid valve to stop the flow of water and will not be triggered again until the reserve is depleted once again. Larger dimensions could be made available for high-traffic areas such as mall bathrooms, airport bathrooms, etc., by simply enlarging the entire machine as a whole. Another possibility for high-traffic areas would be to have one large storage tank of solution and water behind a wall that multiple hand washing mechanisms are connected to in order to decrease the size of the visible machine so more are available for use at one time. This design restructuring would be very beneficial in a stadium/concert venue since there are usually lines for the bathrooms and having more space to put more hand washing stations would be of great value and sanitation. The final part of our water reserve design is to sustain water. To be as efficient as possible after each use the water and solutions runs down the drain. From the drain the waste will run through a filter and send the clean water back to the reserve to be used again. All unclean water than does not pass through the filter will be disposed of through the drain.

### 3.7.4 Final Water Filtration

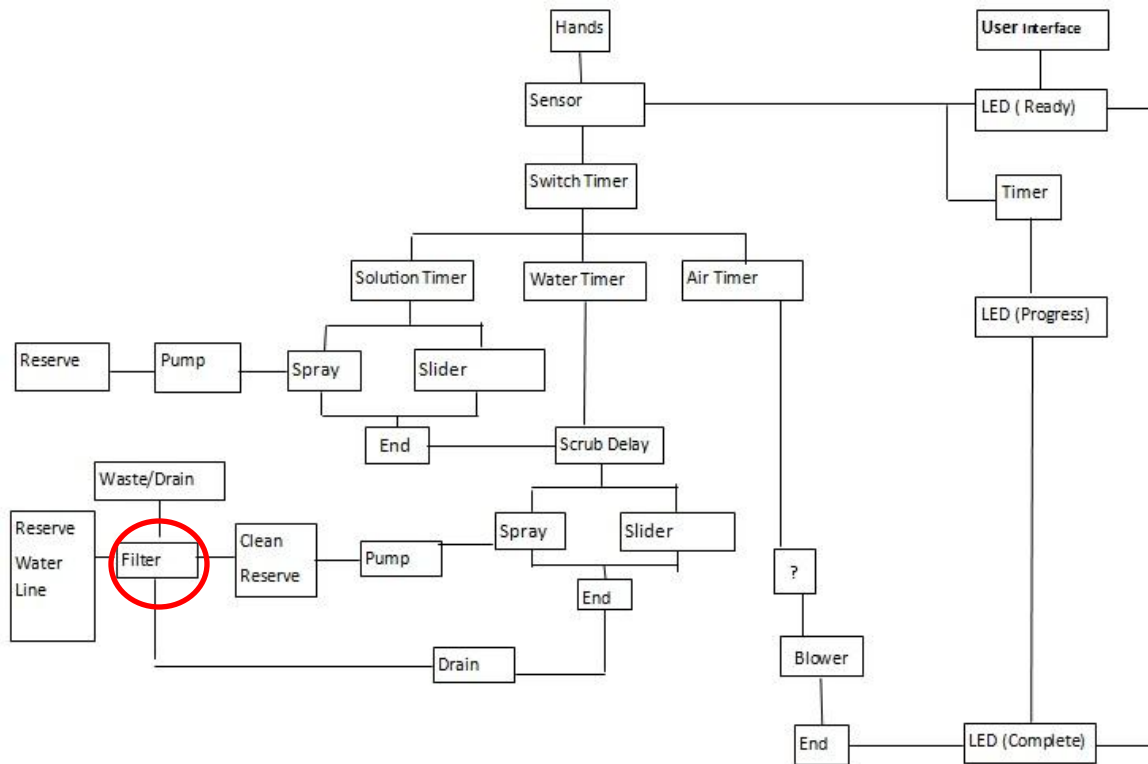

Having a water filtration system in place is necessary to prevent contaminated water from being used to “wash” hands that in the end could become dirtier in the so-called washing process. Filtration works by passing the water one wants to clean through a filter that contains certain chemicals, charcoal, or anything that will chemically attract any contaminants. The chemicals usually have different charges on them depending on the properties of the contaminants one wants to filter out of the water. If a contaminant has a negative charge on one side of its structure, the media for that contaminant would have a positively charged residue ready to bind to the negatively charged residue on the contaminant, which would then take it out of the water source. Certain contaminants would be harder to remove than others, however this water mainly just needs to be free of particulates and such that could irritate ones skin. The filter described in the next section should be able to handle such tasks.

A water filter that seems suitable for this specific application is the HD-950 1" Whole House Filter System found on waterfilters.net (HD-950 1" Whole House Filter System 2001-2011). It has a long lifespan according to the source, and is able to work with heavy-sediment containing liquids. There is a pressure release button on the top of it for when the water needs to be drained if an issue arises in the machine. This would also come in handy for when it needs to be changed out for a new filter. It is also leak or clog resistant since the o-ring that it uses is self-cleaning and seals nicely. The price for this filter system housing ranges from \$52.00-\$49.00 depending on how many one decides on buying. The filter for this housing would cost \$12.00-\$17.00 each depending on the makeup of the filter, being cellulose, polypropylene, or polyester. We will use the polyester water filter (Pentek R30-BB Pleated Polyester Water Filters (9-3/4" x 4-1/2" \$18.99 each) since it is resistant to bacteria and chemicals, and it can handle a large load of water and sediment between cleanings.



Figure 36 is an image of the Pentek R30-BB Pleated Polyester Water Filters (9-3/4" x 4-1/2" from (HD-950 1" Whole House Filter System 2001-2011)



Figure 37 is an image of the Trojan UVMAX A UltraViolet System (Trojan UVMAX A UltraViolet System 2011).

The image above is another option for a water filtration system, a UV cleaning one. This type of water filtration system uses UV-A light to shine on the water that passes through the filter, and the UV-A light kills mostly all pathogens. This would be a good option to use if the water supply was contaminated; however it is not a viable option to use if one is trying to filter out debris and particulates from the water supply. If one were to pair this option with another filter that actually clears the debris, which would be the best option if the cost could be low enough to install each filter practically. The cost of one of the Trojan UVMAX A UltraViolet System is about \$340.



Figure 28 is an image of the Pentek U440 FreshPoint Ultrafiltration Whole House Water System (Pentek U440 FreshPoint Ultrafiltration Whole House Water System 2011).

The water filtration system shown above is easily the most expensive one, coming in around \$2,500. To make up for the cost of the system, the technology housed inside of it is the best. It contains an actual physical barrier with holes that are 0.025 microns in order to purify the water maximally. The maintenance needed for a purification system such as this is very low and it can employ a self-cleaning mode to help increase its lifespan as well (Pentek U440 FreshPoint Ultrafiltration Whole House Water System 2011).

Table 7 - Comparative Analysis of Water Filtration Systems

filtration system	clear debris	clear pathogens	power	maintenance	cost	total
Pentek U440	1	1	3	1	5	11
HD-950	2	3	3	2	1	11
Trojan UVMAX	5	1	3	2	2	13
1 = good	5 = bad					

The table above shows the comparisons between the three filtration systems talked about above, and their relative score to each other in the categories listed across the top. The HD-950 and the Pentek U440 systems each tied for the top spot, however the edge in this comparison would go to the HD-950, because what it lacks in clearing pathogens, the cost is much lower. Since this hand washing mechanism needs to be affordable, one must keep cost in mind, especially since most water supplies won't be contaminated with pathogens.

### 3.7.5 Final Pump Selection

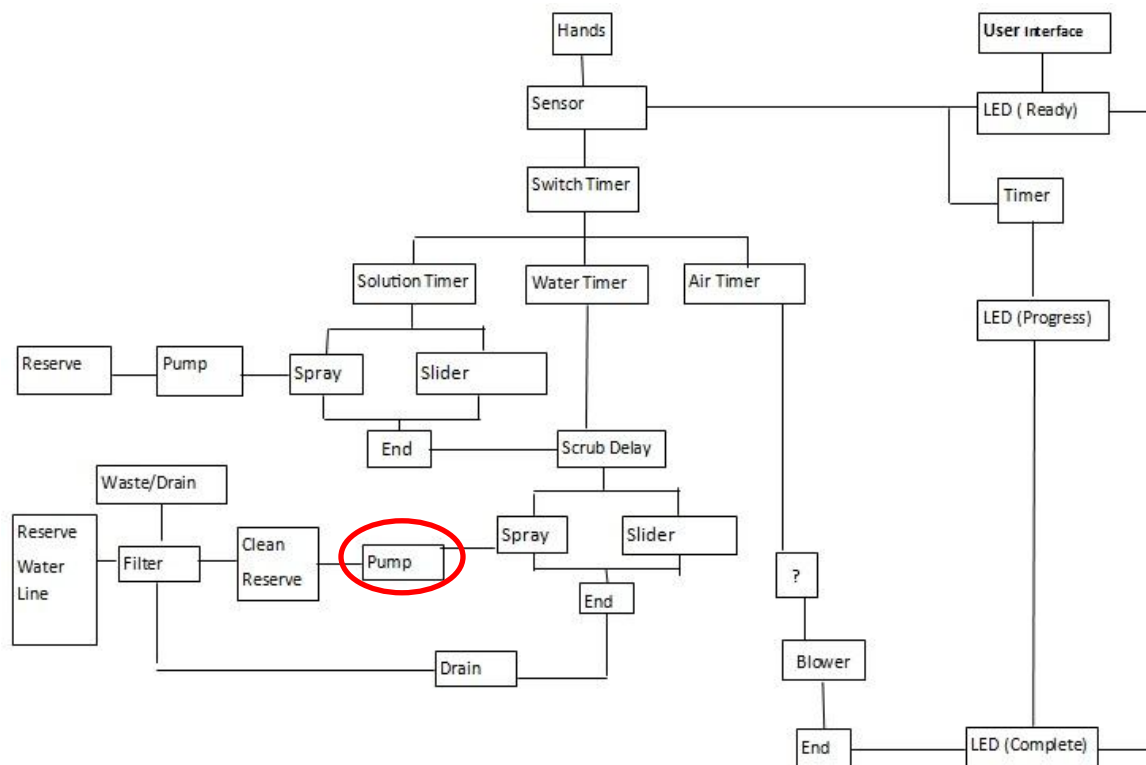

In order to get the liquid solution that will sanitize one's hands actually there, a pump system must be in place to get the solution moving from the reserve onto the person's hands. A couple different systems were looked at and eventually three different ones were analyzed more than others, those being the metered pump system, a lobe pump, and an AODD (air operated double diaphragm) pump. The metered pump would work well since it is able to pump a specific volume of solution out at a time, and since a set amount of solution is needed to be sprayed on the user's hands, this would work out well. A lobe pump is a decently regular type of pump; its moving shafts have no contact due to timing gears though.

### *Metering Pump*

The metered pump doses solutions out with high accuracy. It is able to function with both thin and thick liquids, which is good since this hand washing mechanism may use a variety of different viscosity liquids, with water being the lowest and soaps having scrubbing particles inside being the highest. The only potential issue with utilizing this type of pump is that it uses a very low flow rate. This could be an issue because we are looking for a decently high rate so the solution, if water is a mist, and if a more viscous soap being closer to a solid jet. A low flow rate could cause the solution to dribble out of the nozzle of the sprayer and this would take up more time. Since another feature in our hand washing mechanism is it not taking more than 15 seconds to use, this would create problems. If there is a feature on the metered pump that may be used for this mechanism that can control the flow rate, this issue would be bypassed and the metered pump would be one of the top options to be used based on its volume measuring features (Pump Types Guide 2011).

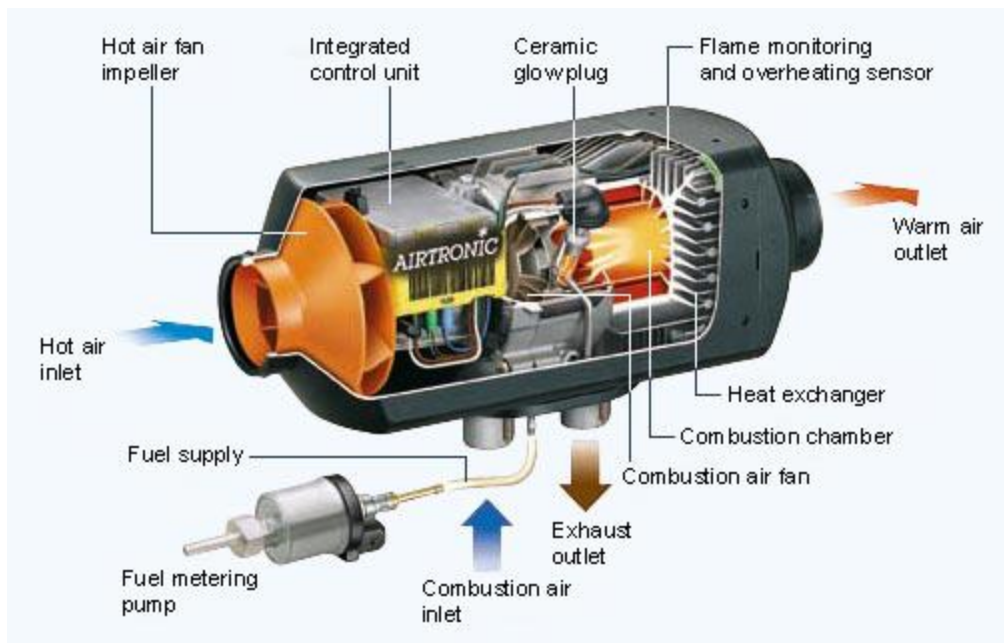

Figure 39 is a picture of a metering pump with the internal workings being shown. <http://www.hydraulicpumpsmotors.com/wp-content/uploads/2010/11/metering-pump1.jpg>

### *Lobe Pump*

The next type of pump that was considered was a lobe pump. These pumps have no contact between the pumping elements inside the machine. This is a convenient feature since this would reduce wear on the machine, which should increase its total working time inside the hand washing mechanism before needing replacement (Comparing 4 Types of PD Pumps 2007). Another reason why this pump would work well inside the hand washing mechanism, is that it can handle solids, which if a heavy duty soap with scrubbing particulates is being used could prove to be beneficial. The flow rate would need to be altered by an outside mechanism if this pump were to be used, which would mean more space is needed inside the machine for it to function properly, which may be an issue if one wants to condense it into a portable hand washing system in natural disaster areas, or even regions of the world that supplies aren't readily available.



Table 8 - Comparing Four Different Pumps (Comparing 4 Types of PD Pumps 2007)

Pump Selection Guide						
	Abrasives	Thin Liquids	Viscous	Solids	Dry Prime	Diff. Pressure
Internal Gear	<b>G</b>	<b>G</b>	<b>E</b>	<b>P</b>	<b>A</b>	<b>G</b>
External Gear	<b>P</b>	<b>G</b>	<b>G</b>	<b>P</b>	<b>A</b>	<b>E</b>
Lobe	<b>G</b>	<b>A</b>	<b>E</b>	<b>E</b>	<b>A</b>	<b>G</b>
Vane	<b>P</b>	<b>E</b>	<b>A</b>	<b>P</b>	<b>G</b>	<b>A</b>

E = Excellent, G = Good, A = Average, P = Poor

This table enabled the team to compare a couple different pumps based on various features each either excelled in or was lacking in. The main thing noticed was the lobe pump was the only one with no “poor” characteristics. This showed it would be handy in different usages. It was also excellent in viscous liquid (liquid soap) which was definitely a necessity. The internal gear pump has an out gear that drives the smaller inner gear, and when they function, the liquid of choice flows into the spaces the gears create. In order to get pumped out the liquid must go back to the mesh and get forced out of the discharge port (Comparing 4 Types of PD Pumps 2007). Generally speaking, the speed at which internal gear pumps work at is slower to centrifugal pumps, which means they work very well with viscous liquids. External gear pumps work the same way as internal gear pumps, the difference is that external gear pumps use two identical gears rotating against each other with four bearings holding them in place. These are better suited for high pressure hydraulics and things of that nature. Finally, vane pumps use slots for the vanes to slide in and out of as the rotor turns. The fit of the vanes in the slots are tight since they are the main sealing element between suction and discharge ports. They are also aided by centrifugal force, hydraulic pressure, or pushrods (Comparing 4 Types of PD Pumps 2007).

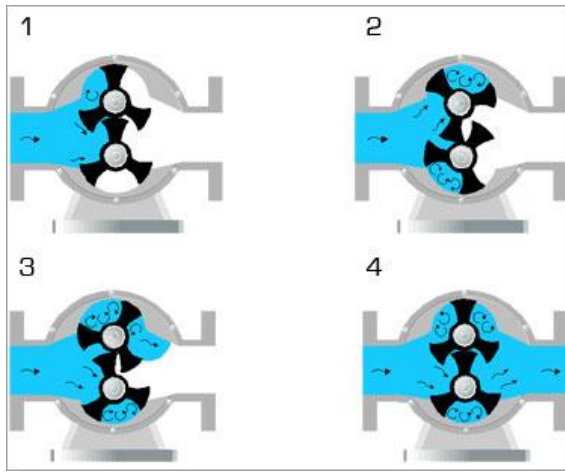

Figure 40 is an image of a rotor pump and how the liquids flow through it [http://www.megator.co.uk/lobe\\_pump.htm](http://www.megator.co.uk/lobe_pump.htm)

### *AODD Pump*

The third and final type of pump that was checked out was the AODD pump. AODD stands for air operated double diaphragm pump. That means that the pump moves liquid by using reciprocating diaphragms to expand and contract a pumping chamber (AODD Pumps & AODD Pump Suppliers 2011). It utilizes two diaphragms expanding and contracting in one direction at a time, and out of the discharge valve. Once this action is completed the other diaphragm is creating a suction to get new liquid into the chamber and start the process all over again. This type of pump is still good for viscous liquids and liquids containing solids, which is of main concern when pumping soap and heavy duty soap. Another advantage to using this type of pump would be its ability to function without any electrical power available. This could then be used in a portable hand washing mechanism designed later on.

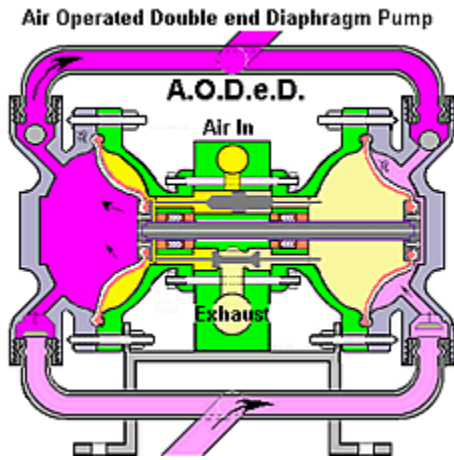

Figure 41 this is a picture of an AODD pump and how it functions <http://www.fluid-flow-control.com/aodd-diaphragm/aodd-diaphragm.html>

Table 9 – Comparative Analysis of Pumps

<b>pump</b>	<b>power usage</b>	<b>flow rate</b>	<b>lifespan</b>	<b>totals</b>
metering	2	1	2	5
AODD	1	2	3	6
lobed	3	5	1	9
1 = good	5 = bad			

This table provides a visual comparison of three different variables taken into consideration when deciding which pump to put into the hand washing mechanism. The metering pump proved to be the best idea along with the AODD style pump being next in line. The lobed pump's only good feature was the longer potential lifespan due to the lack of contact between parts inside. Based off this table, the metering pump style will be the one used in the design of the hand washing mechanism.

### 3.7.6 Final Sensor Selection

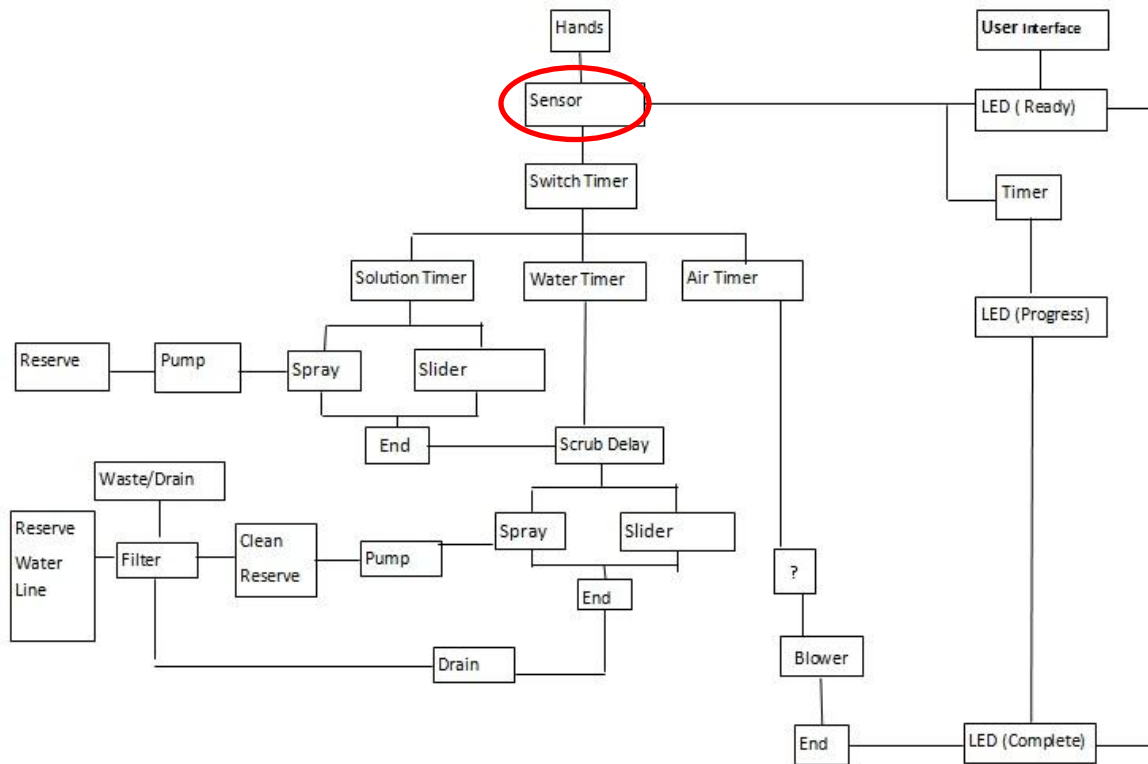

Automatic appliances use sensors that detect motion or an object to turn on or turn off a device. Automatic sinks, hand dryers, and soap dispensers use infra-red proximity sensors. Common infra-red sensors read from approximately 35 centimeters (~14 inches). IR proximity sensors for this application are very cheap and very easy to assemble yourself. They are composed of two infra-red- light emitting diodes, commonly known as IR-LEDs, and sensing unit which is used for the purpose of controlling the circuit and its functions.

Infra-red sensors turn on with a low powered voltage and emit infrared light. Light is produced from one LED and bounces off of objects back to the second LED. When an object, in our case a hand, comes within the optimal range (within 10 inches of the sensor) the reflected light off the object is stronger, in turn producing a greater voltage output. This output travels to the “sensing unit” and turns on the cleansing process. This specific process and how it operates is described in 3.7.8 Final Timer Design. Common IR sensors and their circuits run off of a 5V

power source. For this design that is very low and not a problem because our unit will be connect to the facilities power supply, commonly 120V. The common set up to an IR sensor is seen in Figure 42.

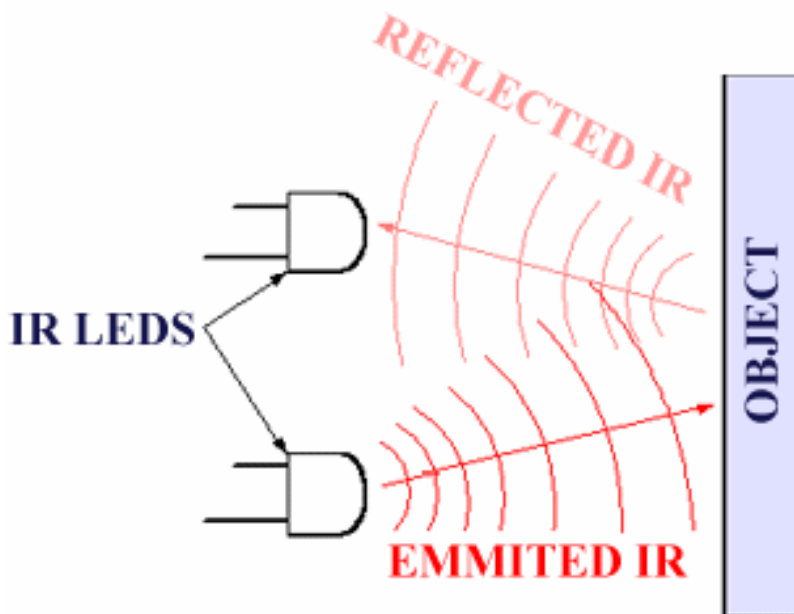
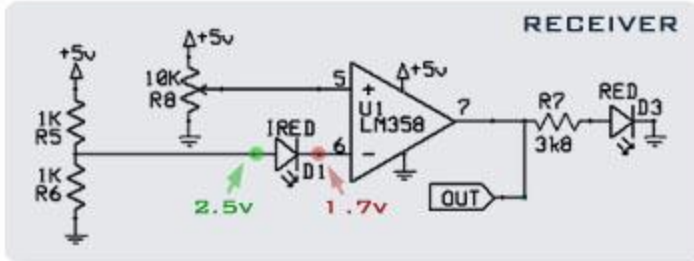

Figure 42 is a common set up of an IR sensor [Kamal, #].

A common component to an IR set up is an operational amplifier. LED's pick up reflected light but that is a voltage output. But this detection of light is really read as a change in voltage. This voltage is usually very low. In turn a traditional Op-Amp is used to enhance and accurately pick up the small changes in Voltage. A common circuit diagram for traditional IR-Sensors can be seen in Figure 43.



LOW RANGE, ALWAYS ON IR PROXIMITY SENSOR  
 DESIGNED BY IBRAHIM KAMAL - IKA@IKALOGIC.COM

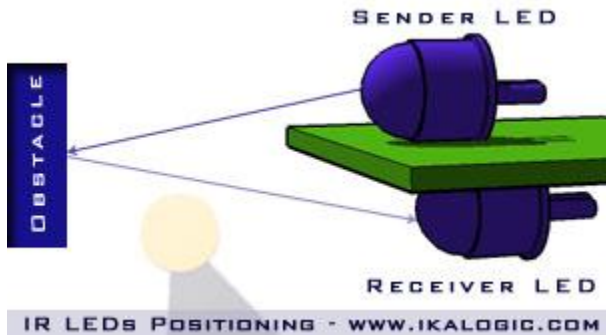
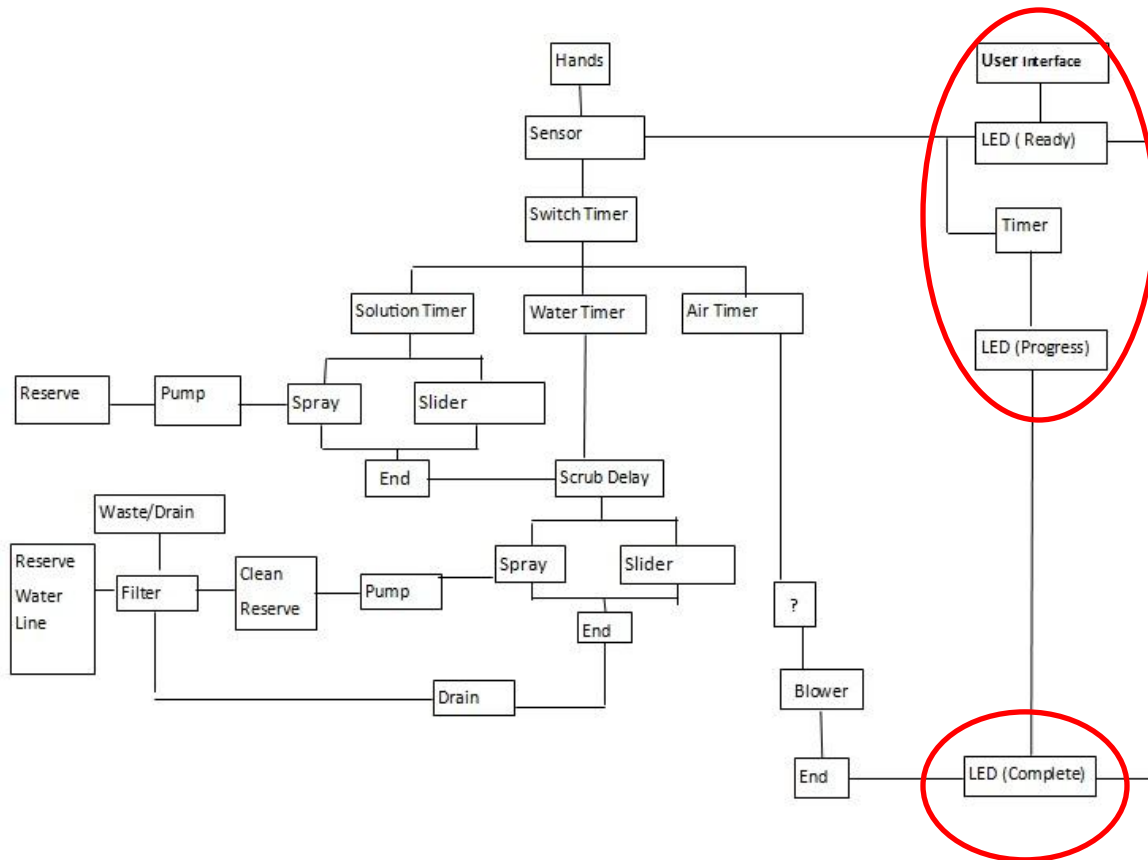

Figure 43 is a common circuit diagram for an IR sensor [Kamal, #].

This is an “ON” IR Proximity Sensor that means the IR LED’s are always emitting IR light and detecting. This will allow users to wash their hands as soon as they place their hands in and the sensor detects the “object”. The above circuit breaks up the sensor into two parts, sending and receiving. Each part has its designated LED that does exactly its part: one sends the infrared light and one receives the infrared light. Resistors can be seen throughout the diagram to convert voltages to output currents to turn the LED’s on. The receiving end created a voltage divider to pick up the change in voltage when objects enter the sensing field. Resistor values are subject to change depending on the specific LED’s selected and the supply voltages. Commonly IR LED’s cost \$0.49 each. The cheap cost and easy set up allows this sensor to be very accessible for the project.

### 3.7.7 Final User Interface



The user interface is the outside of the device that tells the user what is going on. It will tell the user the device is ready to be used, the device is in progress and which steps it is taking, and finally when the device is completed. Colored LED's will be the indicators on the front of the device. Each LED is approximately \$0.42 and can be ordered through the common electrical engineering site Digi-Key.com. There are two options for the user interface design. The device could have 3 or 5 LED's. For the 3 LED combination there would be a "Ready" LED, "In Progress" LED, and a "Done" LED. A more informational design might be more effective for the users so 5 LED's would be used: "Ready", "Soap", "Water", "Blower", "Done". This set up would allow the user to know what to expect especially for people that have never used our product before and might be weary of its actions.

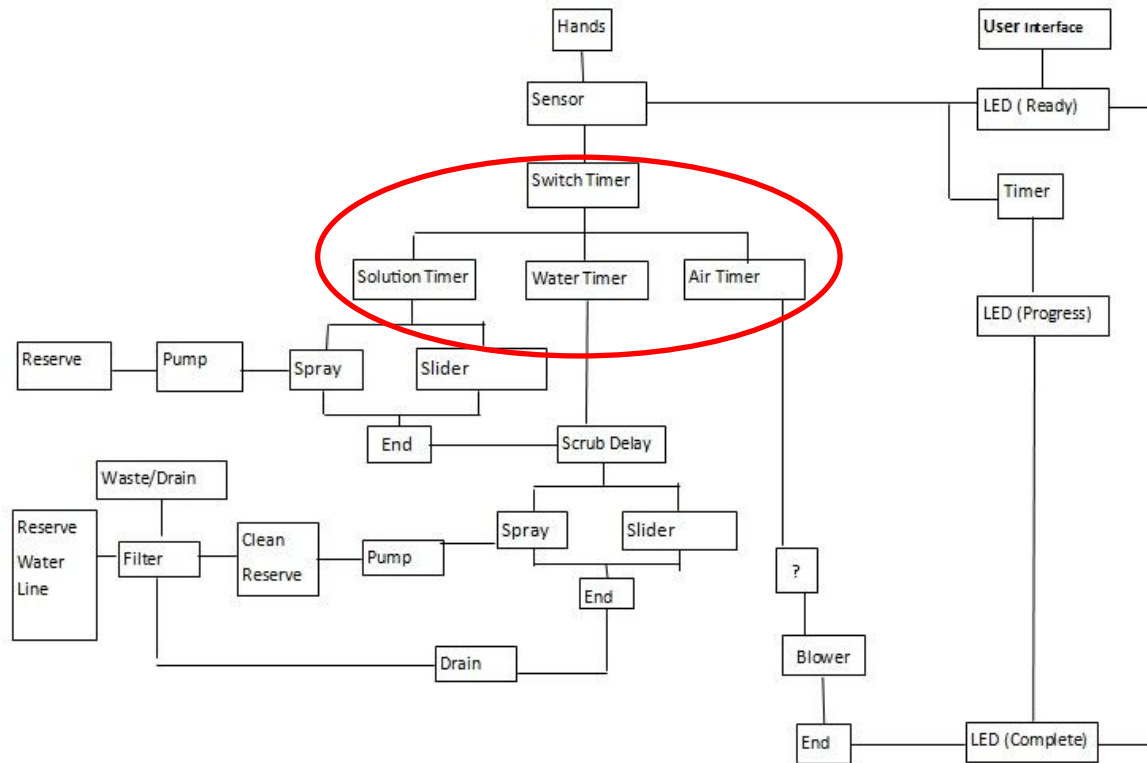

Figure 44 is a common green LED. It can be ordered from [Digi-Key.com](https://www.digikey.com) for \$0.42.

The final aspect of the user interface includes turning each LED on at the right time. This will be controlled with a microcontroller that will control all the functions of the device. The micro controller has an internal timer that will be programmed to turn each process on and off after a certain defined length of time while turning on and off the LED's throughout the process. A detailed description of the micro controller and programming can be found in the next section 3.7.8 Final Timer Design.



### 3.7.8 Final Timer Design



The replacement hand washing device will be active when the user inserts their hands. Soap will dispense over the hands for a period of 4 seconds. Users will have a 3-4 second pause to scrub their hands to get rid of any grime then water will dispense over the hands rising away soap and contaminants for 4 seconds as well. Finally the blower will turn on for 13 seconds allowing the user to pull their hands in and out to dry completely. Along with this process the user interface LED's will turn on and off. Finally after 25 seconds the device will turn off and wait for the next user.

In the flow diagram each of these functions are on a "timer". These timers control the process of the machine. There are a few different circuits that can be created to control the process including using an LM555 timer or a microcontroller. An LM555 timer works by constantly alternating between an ON and OFF state. The frequency and duty cycle can be

changed to control the timing. But because we have so many functions that are time dependent which controlling the user interface at the same time the best option would be to use a microcontroller.

A microcontroller works by obtaining inputs from sensors, processing this input into a set of actions (code), and outputs actions to the device. The micro controller we could use is a MSP430. This is an ultra low power 16-bit microcontroller from Texas Instruments. The MSP430 chip its-self cost \$6.43. the development board as seen in Figure 45cost \$50.

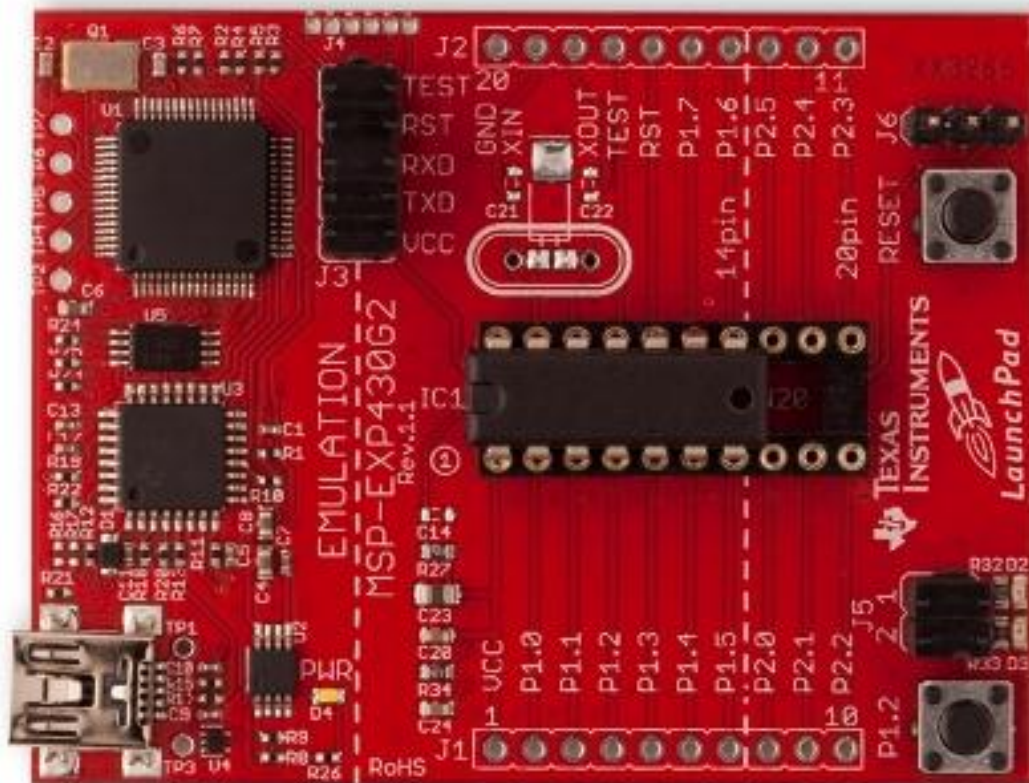

Figure 29 is a picture of an MSP430 from Texas Instruments.

It is best to get a microcontroller from Texas Instruments because they come with training guides, tools, and software to download and help with the set up. While running the MSP430 runs off of 2.2V and 365 micro Amps. When on standby (when users aren't using it) it runs off of 0.5 micro amps.

### Functional Block Diagram, MSP430F241x, 64-Pin PM Package

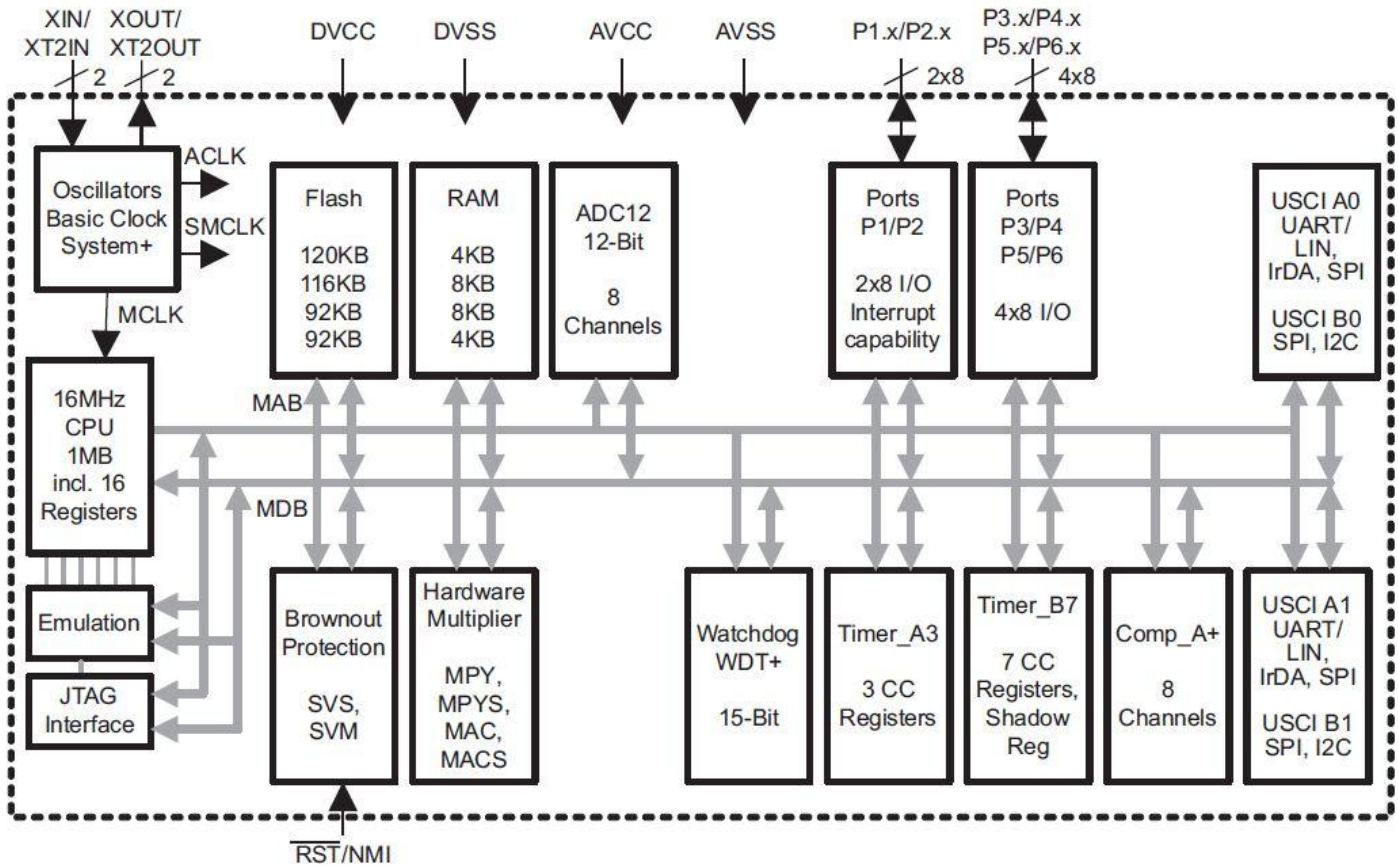

Figure 30 is a block diagram of the MSP430 from Texas Instruments. The MSP430 and its data sheet can be obtained from the common electrical engineering product website Digi-Key.com.

The main part of the microcontroller is the CPU. The CPU runs the set of actions (code) to change the inputs into an output action of the device. In laments terms, the CPU run the code we write and makes the device move.

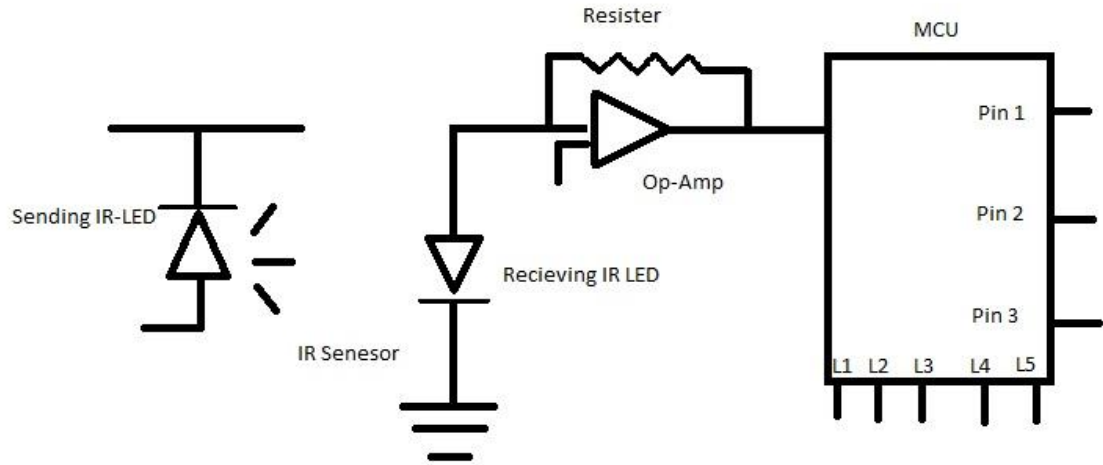

Figure 47 is a basic set up for the IR sensor and micro controller circuit.

When hands enter the device the IR- Sensor the input voltage coming out of the Op-Amp drops. The microcontroller sees this lower voltage and is signaled by its programming to start the process. The Pins connect to the motor or power supplies corresponding to functions of the device: Pin 1 is the action of the soap, Pin 2 is the water, and Pin 3 is the blower. The L's 1-5 are the controls and connections to the user interface LED's. To understand how the microcontroller controls the entire device the sample code below has been developed.

Ready light on L1 = 1

```
If (vout <= 1)
{
start process
ready light on = 0
}
```

```
process
-> turn on Pin 1
L2 on
4 seconds
turn off Pin 1
turn off L2
4 seconds delay
```

```
turn on Pin 2
L3 on
4 seconds
turn off Pin 2
turn off L3

turn on Pin 3
L4 on
13 seconds
turn off Pin 3
turn off L4

L5 on
1 second
```

This code says when no hands are in the device the Vout (voltage) is high. When hands enter the Vout (voltage) becomes low. When Voltage is high the “Ready” LED (L1) is on. When voltage is low the “ready” LED goes off and the process starts. The process is the functions of the device. First Pin 1, the solution, turns on. The “Soap” LED (L2) turns on as well. This goes for 4 seconds then Pin 1 and L2 turns off. There is a 4 second delay for the user to scrub their hands. Next Pin 2, the water, turns on with the “Water” LED (L3). This goes on for 4 seconds again and then shuts off Pin 2 and L3. Finally Pin 3, the blower, is turned on with its corresponding “Blower” LED (L4). After 13 seconds Pin 3 and L4 turn off. L5, the “Done” LED is turned on for 1 second to signify to the user the process is done. After the total of 26 seconds is completed the process is complete. When the next user puts their hands inside the device the process starts up again.

### 3.7.9 Final Water Sprayer

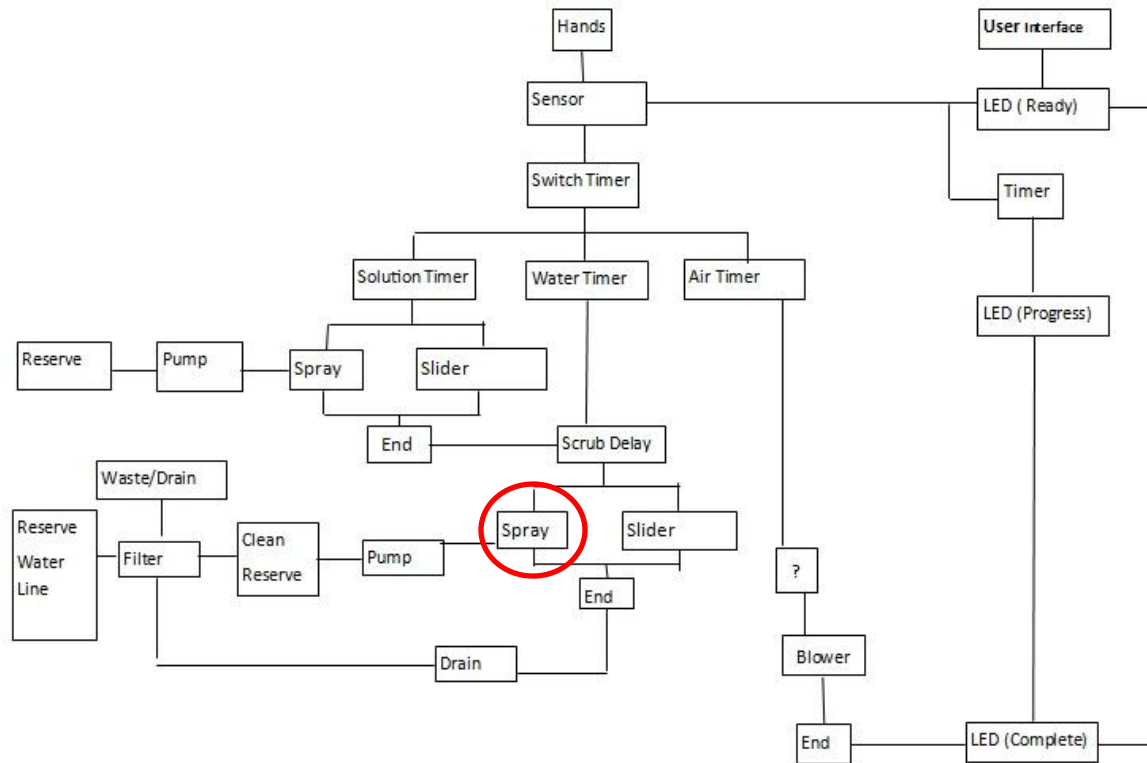

The water sprayer device was tricky to develop to fit in the device as a whole and to function properly to the degree that was requested by guidelines and restrictions for hand washing systems as well as personal requirements the group made. Like the solution sprayer, multiple ideas were put forth and looked into to some degree each and analyzed based on several factors including functionality as well as performance and cost efficiency.

One of the first ideas that were addressed was creating a custom sprinkler of sorts to wrap around the inside of the device in a rectangular pattern and be able to spray the water in all directions around the hands thus rinsing them off fully. This idea involved developing a custom sprayer which would include choosing the material, making the apertures for the sprayer and making sure they conform to the regulations on water pressure and usage per minute. This idea seemed to have too many variables and was set aside while other ideas were presented.

Another idea that was attended to was the idea of using rectangular apertures and flow regulators in order to achieve the correct water flow rate and pattern and to be mounted on a rectangular frame wrapping around the inside of the device. But, again this idea required the use of custom parts to create a rectangular fixture for these to fit into and work off of. Again the thought that there must be some better way put this idea on the side and more were produced.

The last idea, which was chosen, is rationalized after the idea of a sprinkler system for a building with sprinklers spaced on the ceiling every so far. In this case the sprinklers are replaced by nozzle heads that spray in a rectangular pattern in order to optimize the rinsing range of the device as well as to maximize on the allotted allowable pressure for the device. The nozzles are set up in a manner which uses as few as possible while still achieving the goal at hand to be able to rinse thoroughly. The setup for the nozzles is two on the top and two on the bottom, both of which positions are evenly spaced to be at the approximate midpoint of the hands of the average user.

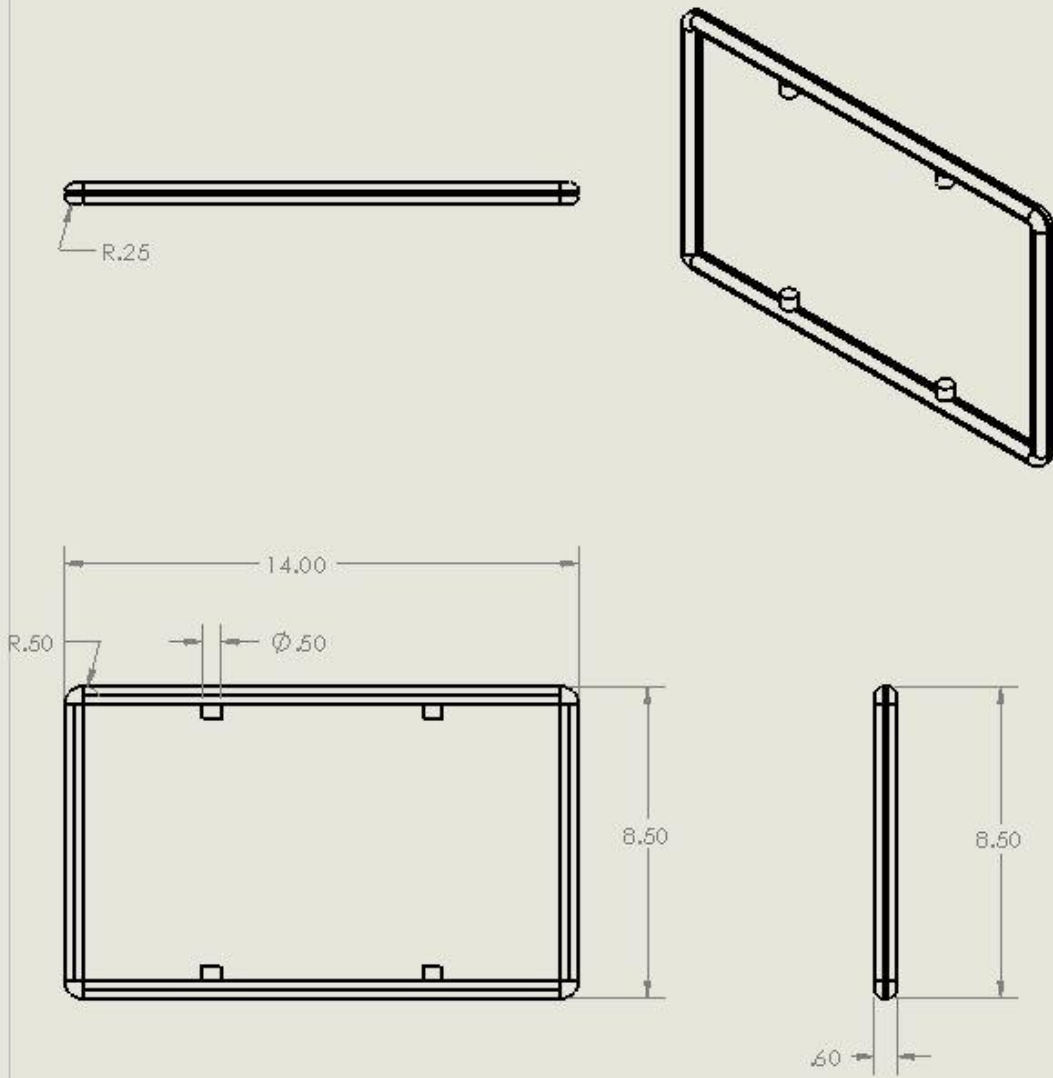

Figure 48 shows optional nozzle heads.

The choice of nozzle heads, which can be seen above in figure 48, was due to the overall motion of the full sanitation device as a whole and since it will act like a automated touch-free carwash we needed the spray pattern to capitalize on that fact and be able to essentially travel in a manner which causes the spray to basically scrape the soap and grime off as it passes by. A

diagram of the nozzles in use can be seen in Figure 49. The nozzles will be attached to a rigid pipe system using T-connections. The pipes will be made out of copper, which is currently used for water transportation anyways, and is easily modified to address the shape that is needed for the device, as well as the rigidity needed to be able to move the device up and down the depth of the device. The system will wrap around and connects all four nozzles together and ultimately end up in the shape of a rectangle and will be attached to a single water line in the bottom corner of the system.





PROPRIETARY AND CONFIDENTIAL  
 THE INFORMATION CONTAINED IN THIS  
 DRAWING IS THE SOLE PROPERTY OF  
 CSPSTEC COMPANY AND IT IS NOT TO BE  
 REPRODUCED OR TRANSMITTED IN ANY  
 FORM OR BY ANY MEANS, WITHOUT THE  
 WRITTEN PERMISSION OF CSPSTEC  
 COMPANY AND IT IS PROHIBITED.

DIMENSIONS ARE IN INCHES DECIMALS: FRACTIONS: ANGULAR: ARCH & BEND: TWO PLACE DECIMALS THREE PLACE DECIMALS		DATE	DATE
DRAWN	DATE	DATE	DATE
CHECKED			
FIG. APPR			
MFG. APPR			
QA			
COMMENTS			
MATERIAL			
FINISH			
APPLICATION	DO NOT SCALE DRAWING		

Worcester Polytechnic Institute	
Sprayer	
JERRY BRADSHAW Senior Lecturer jbradsh@wpoly.edu	
SPT DWG NO	REV
<b>A</b>	
SCALE: 1" = 1"	SHEET 1 OF 1

Figure 31 is a SolidWorks model of the spraying mechanism.

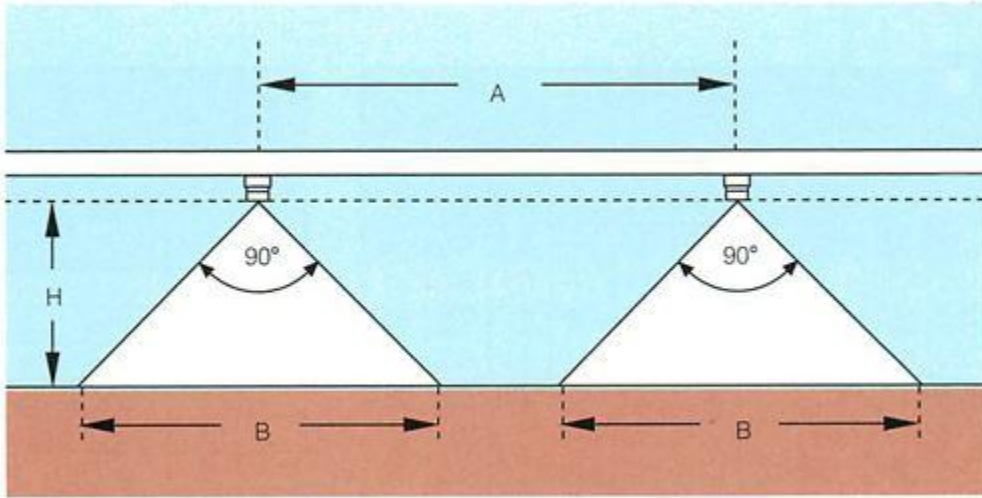
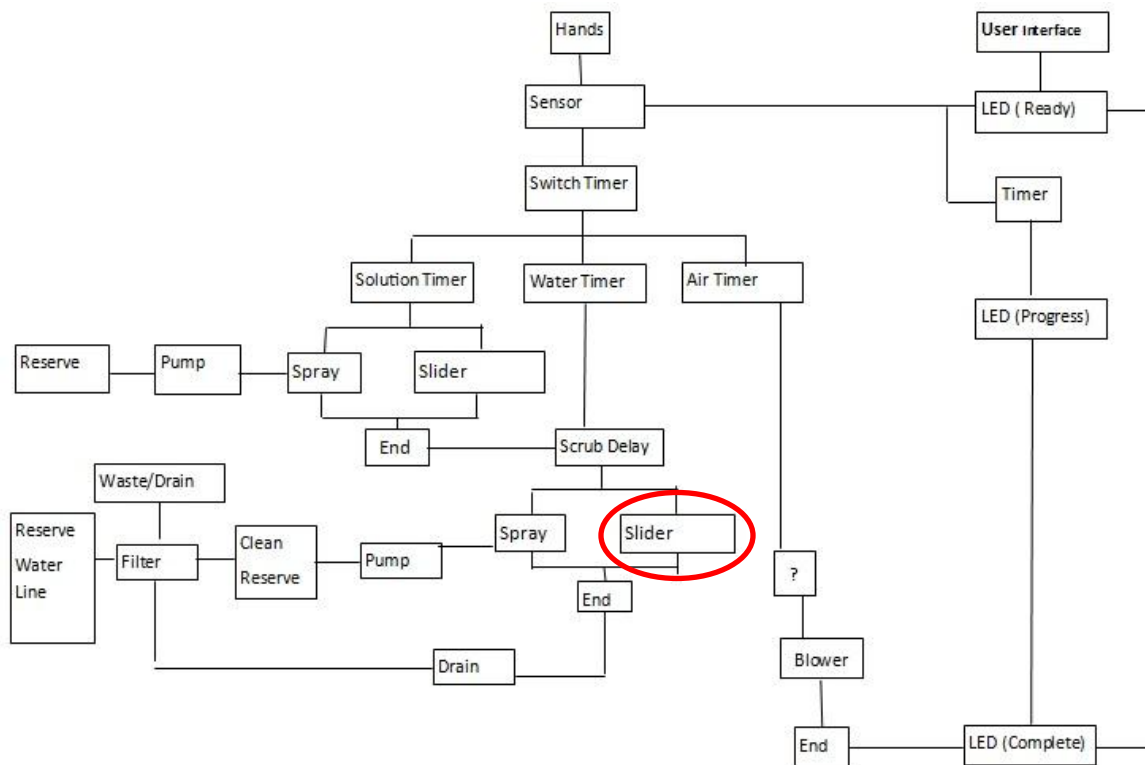

Figure 50 demonstrates the spraying angles.

A screenshot of the full setup of the water sprayer system can be seen in Figure 50, which is a 2-D dimensional drawing showing the locations of the nozzles as well as the overall shape of the apparatus.

### 3.7.9 Final Water Slider



The slider mechanism posed a big problem because there were several factors that needed to be addressed. The first couple of problems that needed to be addressed were the need for it to be able to move on a timer, in a linear manner, have enough power to move the whole sprayer setup when on, be able to reverse direction, be able to move the device at a constant rate , and be able to move at a speed that meets one of the basic requirements of the overall device.

A few attempts at searching for a suitable device were made and each were researched and addressed based on the above stated criteria. A few of the devices or methods for moving the water and solution sprayers were; rack and pinion gearing, simple motor driven linkage, a linear actuator to move the device and a roller track to keep the motion straight and steady, and finally the chosen method of a track actuator.

The rack and pinion gearing setup would have functioned very well as a mechanical device to move the sprayers in a linear manner motion but the problem was that it is extremely technical and has multiple equations for the calculations of the gears that not only are extremely extensive but also very time consuming and cumbersome in the way that you have to choose the gears and the number of teeth and there individual diameters, etc., as well as the motor needed to operate the pinion across the track as well. Seeing as how this can cause a lot of confusion this idea was pushed aside and more were developed.

Another of the ideas that was addressed was to develop a simple linkage powered by a single motor in order to achieve the motion needed to move the sprayer. This again seemed to have numerous calculations and with large numbers of calculations and measurements comes the possibilities of errors forming. Due to this factor pursuing this possibility ceased and again more were addressed.

Finally, the idea to use a linear actuator was brought up and upon research of the linear actuators brought up an even better device, a track actuator, which was ultimately chosen as the number one choice due to the functionality of the mechanism as far as the ease of use and controllability of it as well. The particular specifications on the model that was chosen can be seen in Figure 51. The model that was chosen based upon the requirements that were set forth by the group end up coming off of the Firgelli automations website, [www.firgelliauto.com](http://www.firgelliauto.com), and was a mini Track actuator model number FA-35-TR-10.

**10" Stroke Mini Track Actuator 2" per sec speed and 35lbs force**  
[FA-TR-35-12-10]

[BUY NOW](#)

**SPECIFICATIONS**

- PATENT PENDING DESIGN
- 12vdc nominal voltage
- 35 lbs push/pull force
- 70 lbs max static force
- 5amp current draw at full load
- 2" Sec speed
- IP54 Rating (splash and dust resistant)
- 2-wire harness, reverse polarity to change direction
- Built in limit switches, not movable
- Weight approx 2lbs
- 8 x M5 mounting holes



Click to enlarge

Figure 51 are the track actuator specifications.

This particular actuator works well with the design for the spraying mechanism because the speed of the actuator, 2" per second, is right around the speed needed to obtain the time frame for the motion. Also, this is already wired for both forward and reverse directions which are necessary for the mechanism and has the ability to move well more than the necessary amount of weight. A 3-Dimensional Solidworks drawing of the track actuator along with a 2-D dimensioned drawing can be seen in Figure 52 and Figure 53.

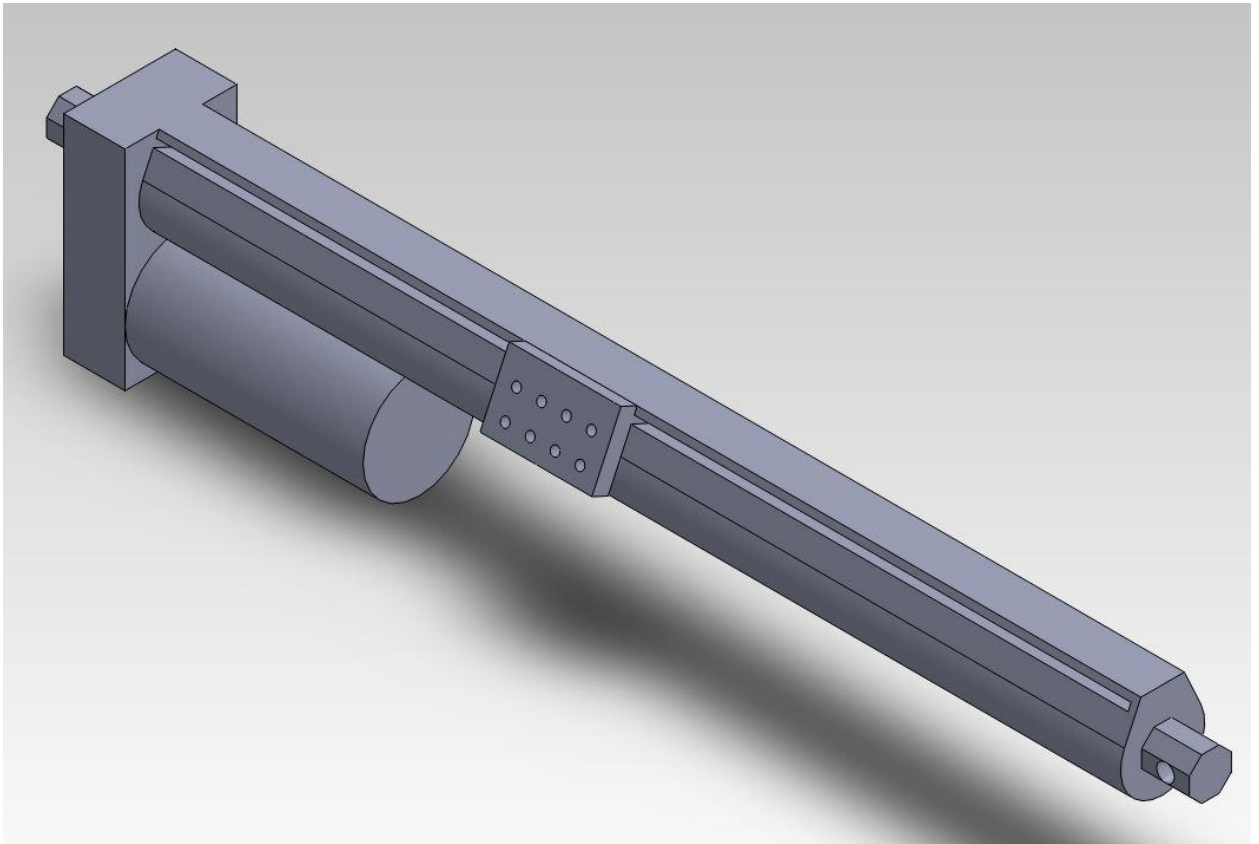

Figure 52 is a 3D SolidWorks model of the track actuator.

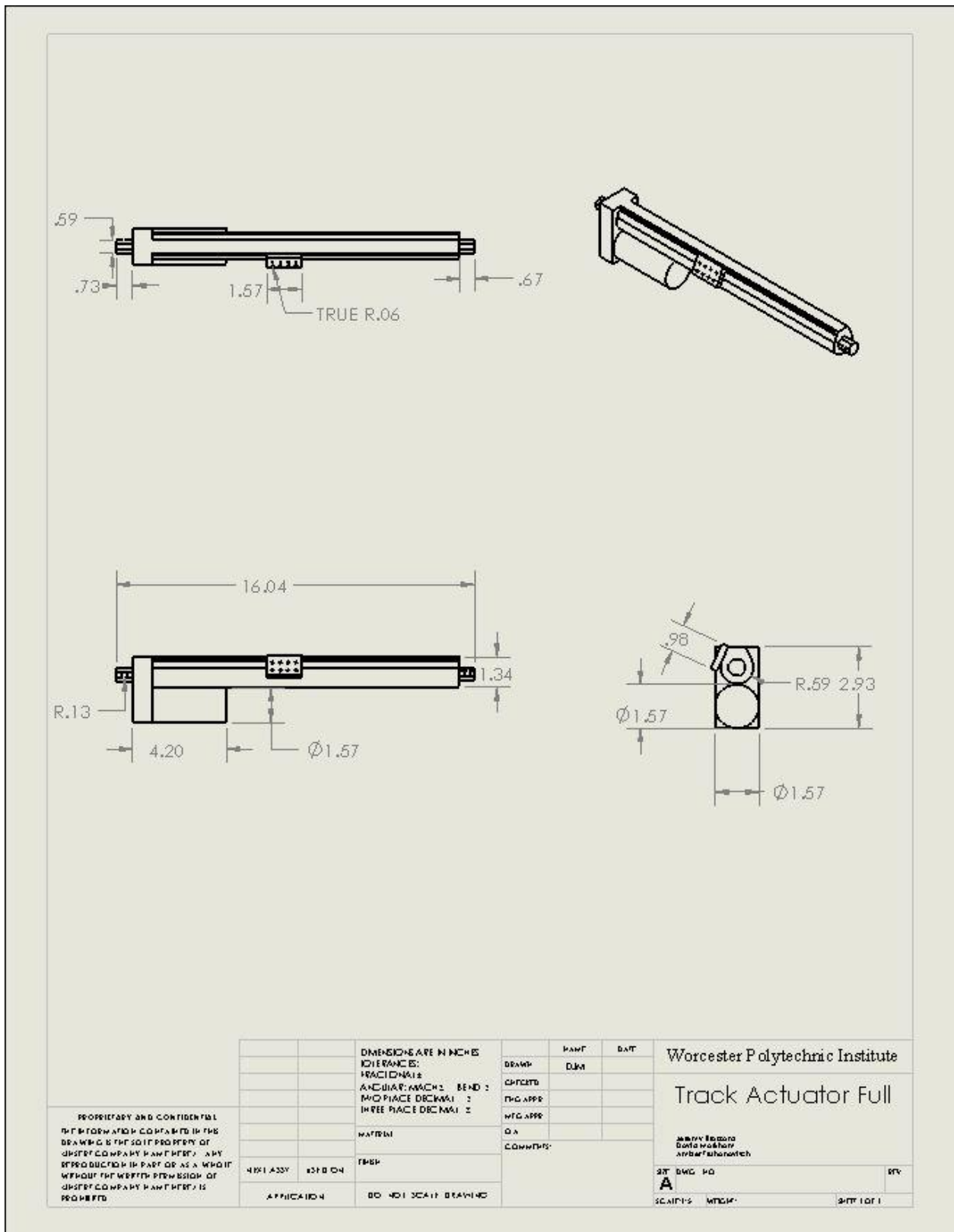
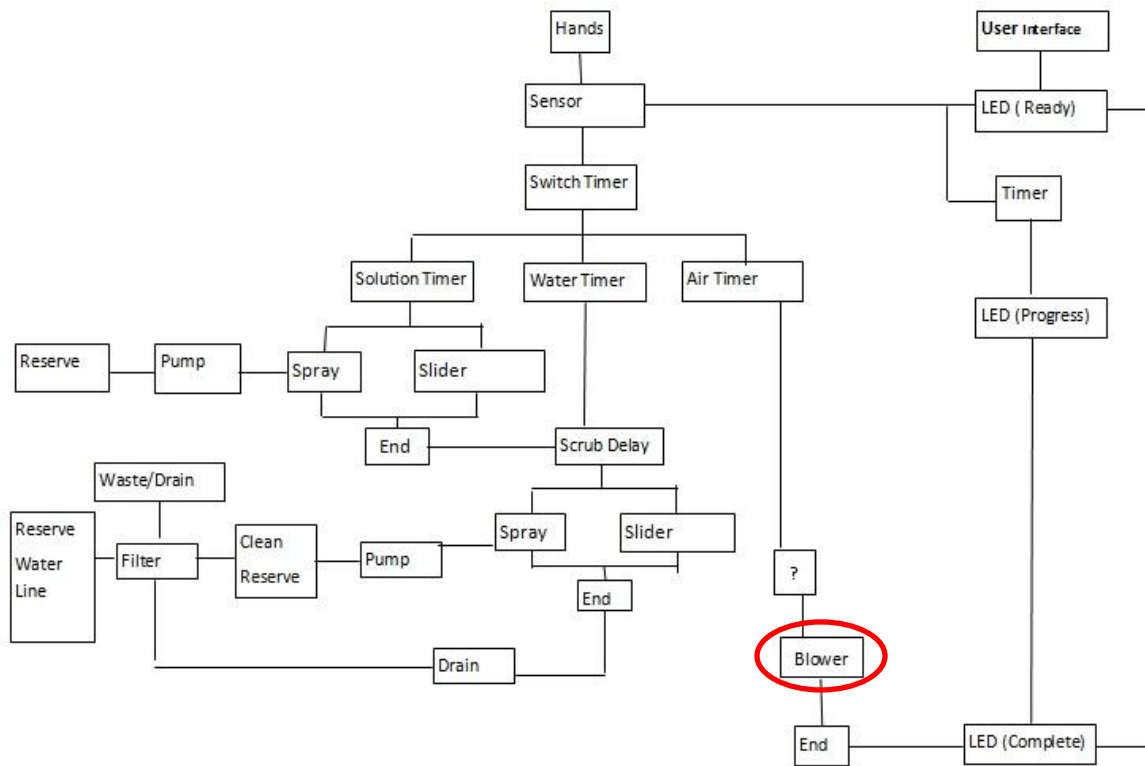

Figure 53 is a 2D dimension drawing of the actuator.

### 3.7.10 Final Blower



The blower design is probably the most complicated part of the project and could be a separate IQP on its own. The basic components that we would need are the components to a hand dryer. Excel Dryers have been making hand dryers for years and a typical hand dryer they use is the HO-IC as seen in Figure 54.



Figure 32 is an Excel HO-IC hand dryer.

This typical product costs about \$200 new. Excel's newest dryers are leading in energy efficiency and drying time. The Xlerator costs \$550 and dries hands in approximately 10 seconds.



Figure 33 is the leading dryer from Excel.

The Xlerator is currently too expensive to put into our product but we can still use Excel's common set up for our blowing mechanism. The basic parts of the blower are seen in Figure 56.



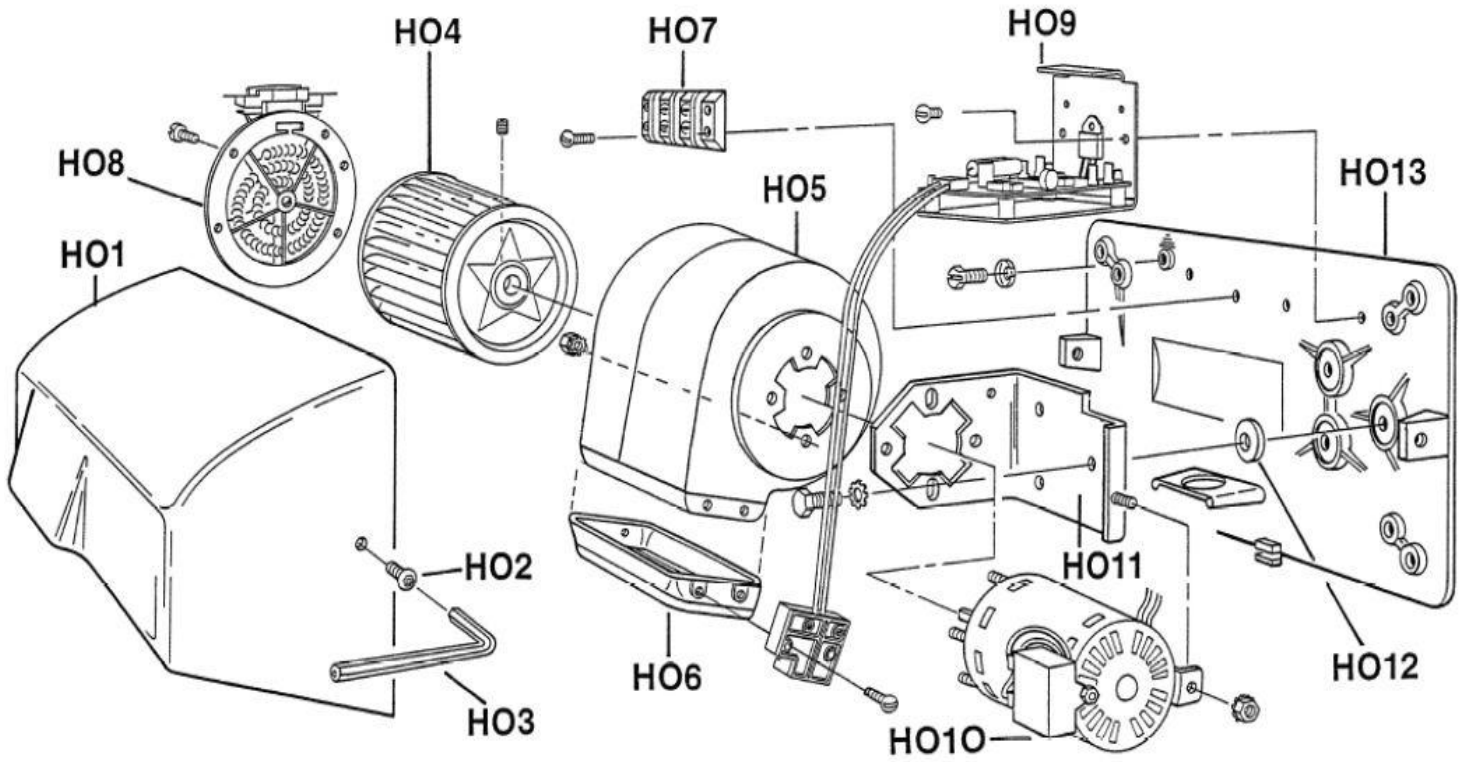

HOIL, HOIW, HOIC Surface Mounted with Capacitor Motor - 9/12/95

Figure 34 is the components in a typical HO-IC Excel hand dryer.

Instead of constructing the blower from scratch, the parts needed can be ordered from Newton Distributing Company. They provide each component from the broken down diagram in Figure 56 from above.

HO-IC; HO-IW Parts

**Your Price: \$ .90**

Manufactured By: Excel Dryer

Parts for the HO-IC; HO-IW Hand Dryers.

LOW PRICE GUARANTEE - See Quantity Discounts Below

Please call 877.837.7745 or EMAIL sales@newtondistributing.com...

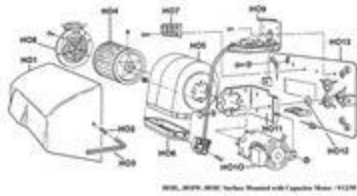

[Click for more Details](#)

PDF Specifications

PART	DESCRIPTION	PRICE/QTY	QTY	
HO 1	HO 1 Cover White	1-6 \$90.00 /ea	<input type="text"/>	
HO 1-2	HO 1-2 Cover Chrome Plated	1-6 \$153.00 /ea	<input type="text"/>	
HO 2	HO 2 Tamper-Proof Bolt	1-6 \$.90 /ea	<input type="text"/>	
HO 3	HO 3 Tamper-Proof Wrench	1-6 \$2.70 /ea	<input type="text"/>	
HO 4	HO 4 Blower Wheel	1-6 \$10.80 /ea	<input type="text"/>	
HO 5	HO 5 Blower Housing - Infrared Sensor	1-6 \$18.00 /ea	<input type="text"/>	
HO 6	HO 6 Blower Vent/Grill- Air Outlet	1-6 \$9.00 /ea	<input type="text"/>	
HO 7	HO 7 Terminal Block	1-6 \$4.50 /ea	<input type="text"/>	
HO 8	HO 8 Heating Element Assembly 110/120V	1-6 \$31.50 /ea	<input type="text"/>	

Our device will not need a cover or chrome plate because it will be housed inside our device. We also will not need the IR sensors because it will be controlled by our MCU.

HO 8-2	HO 8-2 Heating Element Assembly 208/230V	1-6 \$31.50 /ea	<input type="checkbox"/>	
HO 8-3	HO 8-3 Heating Element Assembly 240V	1-6 \$31.50 /ea	<input type="checkbox"/>	
HO 8-4	HO 8-4 Heating Element Assembly 277V	1-6 \$31.50 /ea	<input type="checkbox"/>	
HO 8-5	HO 8-5 Heating Element Assembly 110/120V-1500W	1-6 \$31.50 /ea	<input type="checkbox"/>	
HO 9	HO 9 Dryer Control - Infrared Sensor 110/120V	1-6 \$90.00 /ea	<input type="checkbox"/>	
HO 9-1	HO 9-1 Dryer Control - Infrared Sensor 208/230V	1-6 \$90.00 /ea	<input type="checkbox"/>	
HO 9-2	HO 9-2 Dryer Control - Infrared Sensor 277V	1-6 \$90.00 /ea	<input type="checkbox"/>	
HO 10	HO 10 Motor - Includes Capacitor 110/120V	1-6 \$99.00 /ea	<input type="checkbox"/>	
HO 10-1	HO 10-1 Motor - Includes Capacitor 208/230V	1-6 \$99.00 /ea	<input type="checkbox"/>	
HO 10-2	HO 10-2 Motor - Includes Capacitor 277V	1-6 \$99.00 /ea	<input type="checkbox"/>	
HO 11	HO 11 Motor Bracket	1-6 \$4.50 /ea	<input type="checkbox"/>	
HO 12	HO 12 Motor Bracket Pad	1-6 \$.45 /ea	<input type="checkbox"/>	
HO 13	HO 13 Wall Plate	1-6 \$31.50 /ea	<input type="checkbox"/>	
HO 14	HO 14 Blower Housing - Capacitance Sensor	1-6 \$15.75 /ea	<input type="checkbox"/>	
HO 15	HO 15 Dryer Control - Capacitance Sensor	1-6 \$90.00 /ea	<input type="checkbox"/>	

We probably won't need the Capacitance Sensors either because ours will all be controlled within the MCU. The total cost of the components for the blower will be approximately \$170.

### 3.7.11 Final Design Put Together

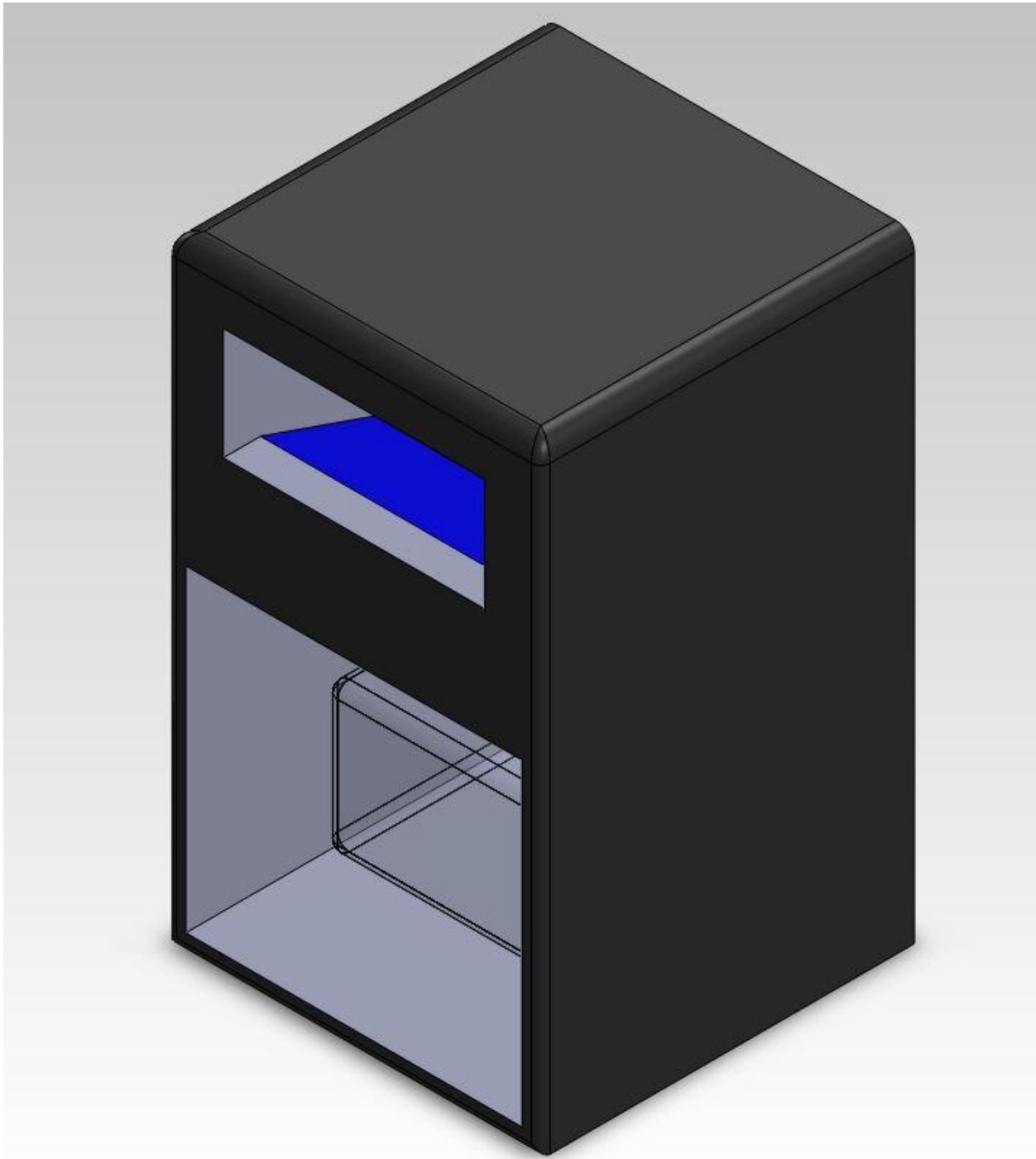

Figure 35 is a SolidWorks model of our final design.

Figure 57 shows an isometric 3-Dimensional view of the outer shell of the overall device. The shell is made of a polycarbonate and completely encases all components within its walls. The large open area on the bottom is for access to the water reserve, pumps, solution reserves, filter, and the main drain. This is closed off on the full device and has a locked door that can be

accessed by the maintenance personnel or owner. The exposed upper section is always open and is the main portion of the device. This is where the user will insert their hands and trigger the sensor to start the program.

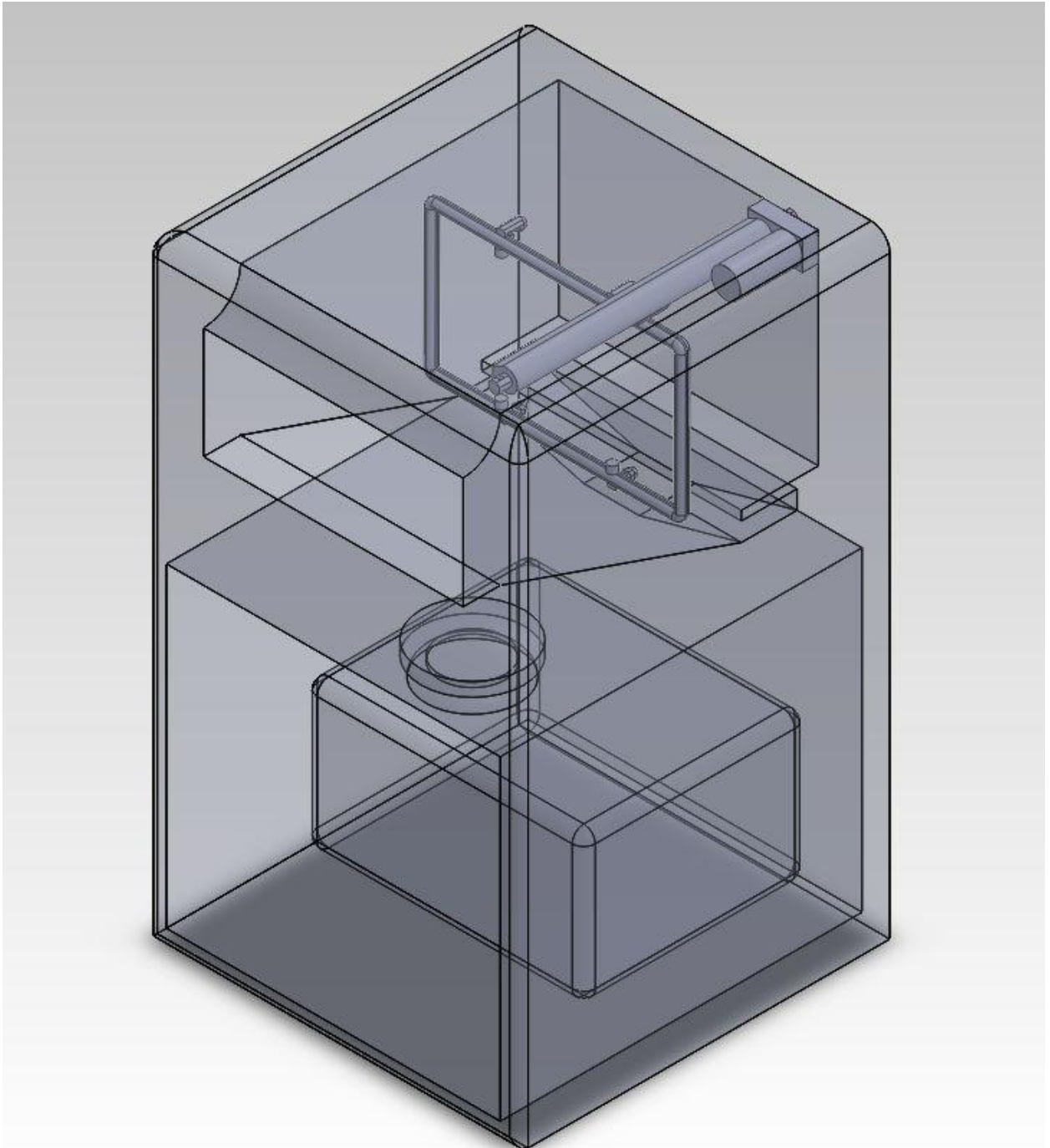

Figure 36 is another SolidWorks model of our final design showing the internal components.

Figure 58 is the same view as Figure 54 of the device but this time showing the interior components through the outer shell of the device. In this view the water reserve tank can be seen in the bottom portion of the device. In the upper portion of the image the track actuator and water and solution sprayers can be seen as well as the sloped bottom surface of the upper most area leading to a drain.



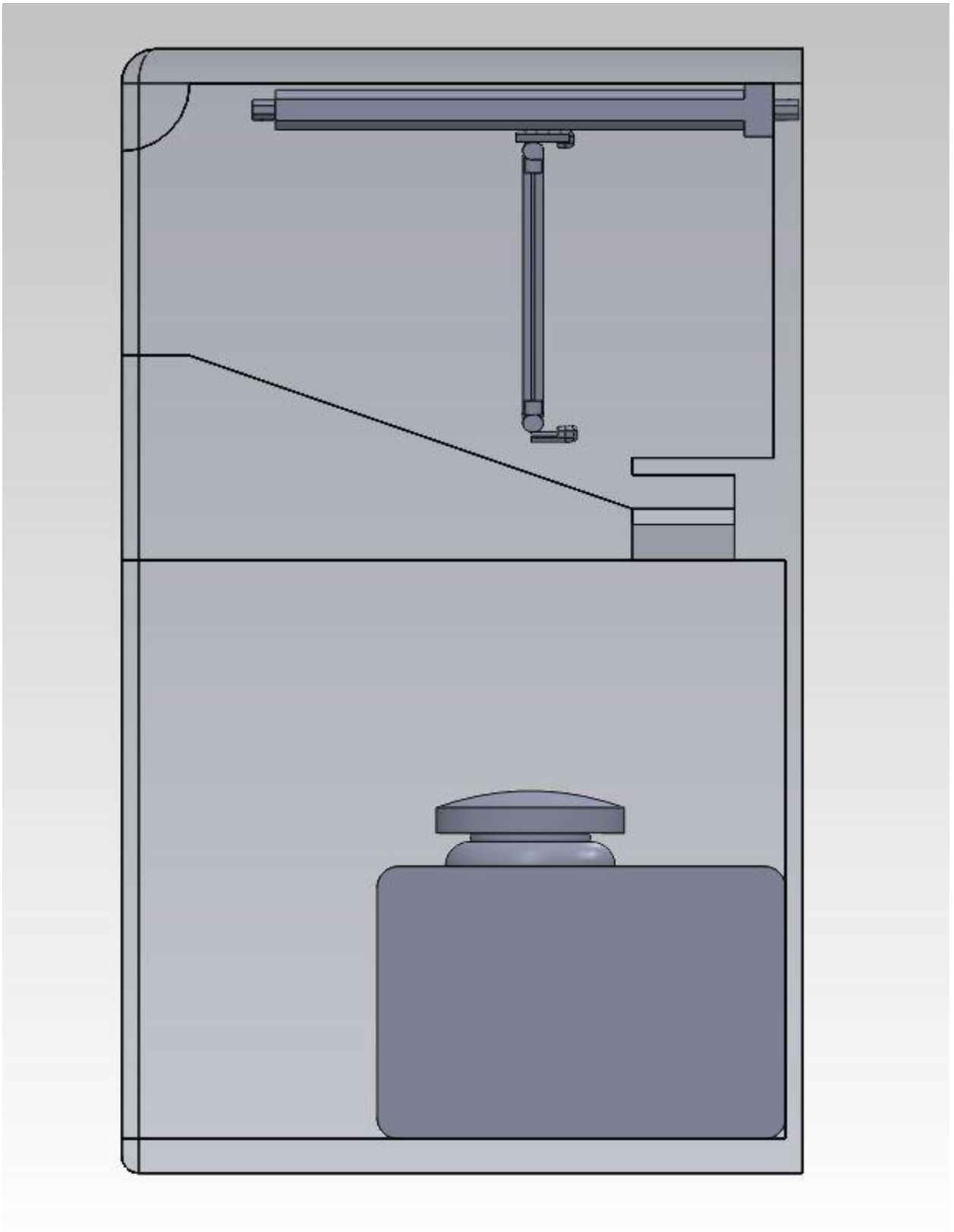

Figure 37 is the side view of the final design in SolidWorks.

In the above image, Figure 59, the positioning as well as detail of the specific components of the device can be seen better. The positioning of the track actuator as well as the sprayer mechanism are both visible here as well as how the base of the main system is pitched to allow for the draining of the used solution and water.



## Chapter 4

### 4.1 Financial Break Down

Our goal was to create this system to be less than or equal to the cost of traditional sinks and bathroom facilities. We have come within a few hundred dollars to current facilities.

#### 4.1.1 Bill of Materials Break Down

<b>Part</b>	<b>Cost</b>
<b>Solution ( a gallon)</b>	<b>\$25.00</b>
<b>Solution System</b>	<b>\$80.00</b>
<b>Water Reserve</b>	<b>\$37.99</b>
<b>Electronic Water level sensor</b>	<b>\$10.00</b>
<b>Filter Housing</b>	<b>\$50.00</b>
<b>Filter</b>	<b>\$18.99</b>
<b>Metering Pump</b>	<b>\$181.00</b>
<b>MSP430</b>	<b>\$6.43</b>
<b>Development Board MCU</b>	<b>\$50.00</b>
<b>IR LED's</b>	<b>\$0.49</b>
<b>IR LED's</b>	<b>\$0.49</b>
<b>Green LED</b>	<b>\$0.42</b>
<b>Green LED</b>	<b>\$0.42</b>
<b>Green LED</b>	<b>\$0.42</b>
<b>Green LED</b>	<b>\$0.42</b>
<b>Green LED</b>	<b>\$0.42</b>
<b>Water Sprayer</b>	<b>\$20.00</b>
<b>Actuator</b>	<b>\$159.99</b>
<b>Blower</b>	<b>\$170.00</b>
<b>Case</b>	<b>\$60.00</b>
<b>Connection hoses/nuts bolts etc</b>	<b>\$100.00</b>
<b>Total</b>	<b>\$972.48</b>

### 4.1.2 Traditional Bathroom Costs

Prices obtained from Uline.com, TouchFree concepts, faucet.com

<b>Part</b>	<b>Cost</b>	<b>Automatic Parts</b>	<b>Cost3</b>
Gojo Soap ( a gallon)	\$25.00	Gojo Soap ( a gallon)	\$25.00
Gojo Soap Dispenser	\$20.00	Gojo Automatic Soap Dispenser	\$26.99
Standard Faucet	\$100.00	Automatic Faucet	\$250.00
Paper Towel Dispenser	\$70.00	Automatic Paper Towel Dispenser	\$100.00
Paper towels (6 rolls)	\$45.00	Paper towels (6 rolls)	\$45.00
Excel- Xlerator	\$540.00	Excel- Xlerator	\$540.00
Bathroom Sink	\$127.88	Bathroom Sink	\$127.88
Bathroom Countertops	\$170.00	Bathroom Countertops	\$170.00
<b>Total</b>	<b>\$1,097.88</b>	<b>Total</b>	<b>\$1,284.87</b>

Although the prices do not differ by a lot the space saving and updated technology is very beneficial.

### 4.2 Ethical Issues

Ethical issues can arise in any situation, no matter how foolproof to it the situation may seem. The hand washing mechanism that has been designed may be as green as it can be with current technology, there will still be those out in the population that don't like the idea since it's not completely green. Certain countries (3<sup>rd</sup> world to be specific) may be opposed to these machines being built if a certain metal or deposit is needed to create the parts inside of it, and in order to get a large enough supply to manufacture these machines companies would need to drill and mine in previously settled areas. This would most likely cause a protest to arise, and that needs to be avoided. Another issue that may occur would be how the water filters are disposed of or recycled. These filters would contain pollutants to natural ecosystems, and if disposed of incorrectly they could damage them. A solid filter recycling program would need to be set up in order to avoid such an issue. Final ethical issues come about with energy. Some think it uses more energy to have automatic devices. Our project is not to agree or disagree. We designed this

device in the mind set of trying to get more people to wash their hands as often as possible. Today people don't like to waste time, this device provides a cost effective and time efficient way to help stop the spread of germs.

### **4.3 Future Modifications**

The design and function of the hand washing mechanism that we designed is a very good starting product to get out in the public to see their response. There will be things that are flawed and others variables that may not of been thought of. Future technologies may be able to be fitted inside or even replace certain features and improve the design and functionality of the machine. All of this will only be known for sure in the future though.

Increasing or decreasing the size of the hand washing mechanism may be one way to modify the design in order to accommodate for different circumstances. Downsizing the machine and obtaining an outside power source for those parts that need them could be a modification used in disaster relief efforts, or in the desolate regions in Africa where no power is, in the Arctic on expeditions, in a submarine whose power may be limited and no trash is wanted, etc. Some parts may be able to be switched out with greener ones as well, with switching the pump from a metered pump to an AODD pump as one example since the AODD pump sometimes needs no power to run. Increasing the size of the hand washing mechanism could result in more stations for people to use in a higher traffic venue, such as stadiums or concert pavilions.

Another modification that could be made would be having different reserves and an option as to what type of cleansing solution one wants to use. The options would most likely be the ones listed in chapter two, but if other, better solutions are developed in the future those

could also potentially find themselves in there as well. Some sort of touch screen may be utilized to choose ones option, or to keep it completely hands free, one could push a tile in front of the machine until their solution comes up on a screen in front of them and once they put their hands in the machine, it goes to work.

A huge portion of modifications can be added to changing current components to more energy efficient technology. The blower mechanism at this point is a definite consideration. Dyson and Excel have extremely fast and energy efficient dryer but they are exceptionally expensive. The blower design is almost an IQP in itself and was very complicated for us to understand under our time constraint. Future IQP could create an energy efficient hand dryer that would properly fit in our device. They could make it fast, safe, efficient, and smaller. More research into finding the best deals on components to make the overall cost cheaper would also be beneficial.

Eventually the best modification for hand sanitation would be using ultra violet (UV) light. It is the new up and coming field. UV light sanitation is extremely fast but the long term effects are not yet fully understood. With more research this system could definitely be upgraded.

#### **4.5 Conclusion**

Our design project goal is to design an improved faster way to wash hands. The device needs to be easy for any person to use and comparable to the gold standard, washing hands with soap and water. Ideally this technology will get rid of grime, kill germs, and dry hands all in less than 15 seconds. The optimal design will use minimal energy and filtered water for sustainability, as well as decrease usage costs. Finally the device will have a cost comparable to current public facilities and be safe for all users.

In the end we designed a great starting point to the replacement hand washing system. With our current design we can completely wash and dry hands in 25 seconds. Our goal was to create this system to be less than or equal to the cost of traditional sinks and bathroom facilities. We have come within a few hundred dollars to current facilities. Our device allows users to get grime off their hands, kill germs, and dry hands quickly and efficiently. We were unable to design a system that washed and dried less than 15 seconds mainly because our track actuator that allows the sprayer to travel the length of the hands needs 4-5 extra seconds to travel from the soap stage to the water stage. If we were able to design the device with two or even a larger track actuator the device would be operating in about 18-20 seconds.

Our design utilizes filtering before disposing of waste and a pump with low flow rate so that we can help sustain water. We are also using low energy components to help on sustain all the energy we can. Future GREEN improvements could definitely improve the system.

Our IQP team is proud of the design we have come up with and hope another team can use our knowledge and starting components to actually build a more energy efficient and cost efficient way to wash hands.

## Works Cited

- [1] Advameg, Inc. (2011). *Science Clarified*. Retrieved 2011, from Bacertia.
- [2] Albert, S. B., & Thomas, W. B. (1989, February 16). *Patent No. 4946070*. United States.
- [3] American Ultraviolet, 2011, Lebanon, IN.  
[http://www.americanultraviolet.com/germicidal\\_solutions/why\\_uvc/faq.cfml](http://www.americanultraviolet.com/germicidal_solutions/why_uvc/faq.cfml)
- [4] Center for Disease Control and Prevention, 2011, “Handwashing: Clean Hands Save Lives”.
- [5] Chardack, W. M. (1996). *Patent No. 5,727,579*. United States.
- [6] Colorado Department of Public Health and Environment. (2004, December). *Infectious Disease In School Settings*. Denver, Colorado.
- [7] Davies, J. R. (1985). *Patent No. 4,606,085*. United States.
- [8] Depot, O. (n.d.). *Office Depot*. Retrieved October 5, 2011, from <http://www.officedepot.com/a/products/625999/Purell-NXT-Hand-Sanitizer-Dispenser/>
- [9] Dispensers, D. (n.d.). *Dolphin Dispensers Hot Air Dryers*. Retrieved September 19, 2011, from <http://www.dolphindispensers.co.uk/products/bc2200sa-r-dolphin-recessed-hot-air-dryer/154.htm>
- [10] Dunkin, M. (2009). *Surprisingly dirty places in your home*. Retrieved September 2011, from <http://women.webmd.com/home-health-and-safety-9/places-germs-hide>
- [11] Dyson. (n.d.). *Dyson Airblade*. Retrieved September 19, 2011, from <http://www.dysonairblade.com/homepage.asp>
- [12] Ennis, G. T., & Chelton, R. G. (1986). *Patent No. 4,652,368*. United States.
- [13] Environmental Health & Safety, 2007, “Hazards of ultraviolet Light,” University of Washington.  
<http://www.ehs.washington.edu/rsononion/uvlight.shtm>
- [14] Foster, F. (1997). *Patent No. 6,125,482*. United States.
- [15] Fraser, S. L. (2011, September 19). *Medscape: Drugs, Diseases & Procedures*. Retrieved 2011, from Enterococcal Infections: <http://emedicine.medscape.com/article/216993-overview>
- [16] Lyon, D. E. (2008). *Patent No. 7888657*. United States.
- [17] Maddison, D., & Dawson, C. (1983, November 28). *Patent No. 4573612*. United States.
- [18] Minnesota Department of Health, 2005, “Handwashing: Prevent Disease & Outbreak Intervention,” Minnesota Food Safety Partnership.  
<http://www.health.state.mn.us/handhygiene/curricula/curriculumadult.pdf>
- [19] Rybicki, E. (2011, September 28). *ViroBlogy*. Retrieved October 2011, from Virus Origins: from what did viruses evolve or how did they initially arise?: <http://rybicki.wordpress.com/2008/03/19/from-what-did-viruses-evolve-or-how-did-they-initially-arise/>

- [20] Southeastern District Health Department, 2008, "The Importance of Hand washing," Pacatello, Idaho. <http://www.sdhdidaho.org/hpro/handwashing.php>
- [21] St. Mary Medical Center, 2011, "Handwashing Facts and Tips". Langhorne, PA. <http://www.stmaryhealthcare.org/body.cfm?id=555953>
- [22] Stanley E. Flowers, S. (1998). *Patent No. 5,924,148*. United States.
- [23] Staples. (n.d.). *Staples*. Retrieved October 5, 2011, from [http://www.staples.com/Purell-TFX-Touch-Free-Hand-Sanitizer-Dispenser/product\\_675291](http://www.staples.com/Purell-TFX-Touch-Free-Hand-Sanitizer-Dispenser/product_675291)
- [24] Thellmann, R. (1998). *Patent No. 6,013,181*. United States.
- [25] Thobaben, M., 2010, "Germs: Prevent the Spread of Infectious Diseases," Home Health Care Management & Practice, Sage Publications. <http://hhc.sagepub.com.ezproxy.wpi.edu/content/22/3/238.full.pdf+html>
- [26] Todar, K. (2011). *Online Textbook of Bacteriology*. Retrieved 2011, from Staphylococcus aureus and Staphylococcal Disease: <http://www.textbookofbacteriology.net/staph.html>
- [27] Wolf, J., 2010, "Tissue Culture Methods," Department Biological Sciences UMBC, Baltimore, MD. <http://userpages.umbc.edu/~jwolf/method5.htm>

## Appendix A

Table 10 gives a detailed description of the bacterial, viral, or fungal name, the incubation period, how the contagion is transmitted between people, and how long one is usually contagious or sick for (Environment [13]).

DISEASE/AGENT	INCUBATION PERIOD	TRANSMISSION	CONTAGIOUS PERIOD
<b>E. coli O157:H7 and other Shiga Toxin Producing Bacteria</b> <i>Escherichia coli</i> bacteria	2-10 days (usually 3-4 days)	Fecal-oral spread, contaminated food/water, animals	While diarrhea is present; can spread for 1-3 weeks after symptoms are gone
<b>Fifth Disease</b> Human parvovirus B19	4-21 days	Droplet/infectious discharges	1 week before rash formation
<b>Genital Herpes</b> Herpes simplex virus	2-14 days	Sexual transmission	Potentially lifelong
<b>Genital Warts</b> Human papilloma virus	1 month-several years (usually 2-3 months)	Sexual transmission	Potentially lifelong
<b>Giardiasis</b> <i>Giardia lamblia</i> parasite	3-25 days (usually 7-10 days)	Fecal-oral spread, contaminated food/water	While diarrhea is present; can spread for months after symptoms are gone
<b>Gonorrhea</b> <i>Neisseria gonorrhoeae</i> bacteria	2-7 days	Sexual transmission	Until treated
<b>Hand, Foot and Mouth Disease</b> Strains of enteroviruses	3-6 days	Droplet/infectious discharges, fecal-oral spread	During the first week of illness; virus can be present in stool 4-6 weeks
<b>Head Lice (Pediculosis)</b> <i>Pediculus humanus</i> , the head louse	Nits hatch in 10-14 days, adults live 3-4 weeks	Direct contact with an infested person/object	As long as live lice are present
<b>Hepatitis A</b> Hepatitis A virus	15-50 days (usually 25-30 days)	Fecal-oral spread, contaminated food/water	Most contagious 2 weeks before symptom onset and slightly contagious 1 week after jaundice onset
<b>Hepatitis B</b> Hepatitis B virus	2-6 months (usually 2-3 months)	Infective blood or body fluids, sexual transmission	Several weeks before symptom onset and throughout the illness, some
<b>Hepatitis C</b> Hepatitis C virus	2 weeks-6 months (usually 6-7 weeks)	Infective blood	1 or more weeks before symptom onset and as long as the virus is present in the blood which can be lifelong
<b>Herpes (Cold Sores, Fever Blisters)</b> Herpes simplex virus	2-12 days	Direct contact	As long as the sores are present
<b>HIV and AIDS</b> Human immunodeficiency virus	Variable	Infective blood	Lifelong
<b>Impetigo</b> Streptococcal or staphylococcal bacteria	7-10 days	Skin contact/direct contact	As long as there is discharge from the affected areas
<b>Influenza</b> Influenza virus	1-4 days (usually 2 days)	Droplet/infectious discharges	From slightly before symptom onset to about day 3 of the illness
<b>Measles (Rubeola)</b> Measles virus	7-18 days (usually 10-12 days)	Airborne	4 days before rash onset to 5 days after
<b>Meningitis (Bacterial)</b> Bacteria such as <i>Neisseria meningitidis</i> (meningococcal), <i>Haemophilus influenzae</i> (H. flu), <i>Streptococcus pneumoniae</i> (pneumococcal)	Depends on the agent (usually 1-10 days)	Droplet/infectious discharges	Until completing 24 hours of antibiotic treatment
<b>Meningitis (Viral)</b> Several different viruses	Depends on the agent	Droplet/infectious discharges, fecal-oral spread	Depends on the agent
<b>Mononucleosis</b> Epstein-Barr virus	30-50 days	Saliva	Up to a year after the initial infection



<b>DISEASE/AGENT</b>	<b>INCUBATION PERIOD</b>	<b>TRANSMISSION</b>	<b>CONTAGIOUS PERIOD</b>
<b>MRSA</b> Methicillin-resistant <i>Staphylococcus aureus</i>	Variable	See CDPHE guidelines	See CDPHE guidelines
<b>Mumps</b> Mumps virus	12-25 days (usually 16-18 days)	Droplet/infectious discharges, saliva	7 days before swelling onset to 9 days after
<b>Nongonococcal Urethritis</b> Various bacteria and viruses	Depends on the agent	Sexual transmission	Depends on the agent, can be contagious until treated
<b>Pelvic Inflammatory Disease</b> Various bacteria	Depends on the agent	Sexual transmission	Depends on the agent, can be contagious until treated
<b>Pink Eye (Conjunctivitis)</b> Various bacteria and viruses, allergies, chemical irritation	Bacterial: 24-72 hours Viral: 1-12 days Allergies: variable Chemicals: variable	Bacterial and viral: infectious discharges Allergies and chemicals: not contagious	Bacterial: as long as symptoms are present or until 24 hours after treatment Viral: as long as symptoms are present
<b>Pubic Lice (Crabs)</b> <i>Phthirus pubis</i> , the pubic louse	Average life cycle is 15 days	Sexual transmission	As long as lice are present
<b>Ringworm (Tinea)</b> Several fungi species	Unknown	Skin contact/direct contact	As long as skin is affected
<b>RSV</b> Respiratory Syncytial Virus	2-8 days (usually 4-6 days)	Droplet/infectious discharges	3-8 days after symptom onset
<b>Rubella (German Measles)</b> Rubella virus	12-23 days (usually 16-18 days)	Droplet/infectious discharges	7 days before rash onset to 7 days after
<b>Salmonellosis</b> <i>Salmonella</i> bacteria	6-72 hours (usually 12-36 hours)	Fecal-oral spread, contaminated food/water, animals	While diarrhea is present; can spread for a variable period of time after symptoms are gone
<b>Animal Bites/Rabies</b> Rabies virus	Rabies: 9 days-7 years (usually 3-8 weeks)	Saliva of an infected animal	As long as symptoms are present
<b>Campylobacteriosis</b> <i>Campylobacter</i> bacteria	1-10 days (usually 2-5 days)	Fecal-oral spread, contaminated food/water, animals	While diarrhea is present; can spread for a few days after symptoms are gone
<b>Chickenpox (Varicella)</b> Varicella-zoster virus	10-21 days (usually 14-16 days)	Droplet/infectious discharges, skin contact	1-2 days before the rash appears until all the blisters have crusted over
<b>Chlamydia</b> <i>Chlamydia trachomatis</i> bacteria	7-14 days or longer	Sexual transmission	Until treated
<b>CMV</b> Cytomegalovirus	3-12 weeks	Body secretions (primarily saliva and urine)	As long as the virus is present in body secretions (months or years)
<b>Common Cold</b> A variety of viruses	1-3 days (usually 48 hours)	Droplet/infectious discharges	1 day before symptom onset until 5 days after
<b>Cryptosporidiosis</b> <i>Cryptosporidium parvum</i> parasite	1-12 days (usually 7 days)	Fecal-oral spread, contaminated food/water, animals	While diarrhea is present; can spread for several weeks after symptoms are gone

<b>DISEASE/AGENT</b>	<b>INCUBATION PERIOD</b>	<b>TRANSMISSION</b>	<b>CONTAGIOUS PERIOD</b>
<b>Scabies</b> <i>Sarcoptes scabiei</i> , a mite	2-6 weeks if never infected, 1-4 days if infected before	Skin contact/direct contact	Until the mites and eggs are destroyed
<b>Shigellosis</b> <i>Shigella</i> bacteria	1-7 days (usually 1-3 days)	Fecal-oral spread, contaminated food/water	While diarrhea is present; can spread for weeks after symptoms are gone
<b>Shingles (Herpes Zoster)</b> Varicella-zoster virus	10-21 days (usually 14-16 days)	Skin contact	Until all the blisters have crusted over
<b>Strep Throat</b> <i>Streptococcus pyogenes</i> bacteria	2-5 days	Droplet/infectious discharges	Until treated with antibiotics for 24 hours, or 10-21 days for untreated cases
<b>Syphilis</b> <i>Treponema pallidum</i> bacteria	10 days-3 months (usually 3 weeks)	Sexual transmission	Until treated
<b>Tetanus</b> <i>Clostridium tetani</i> bacteria	2 days-months (usually 8-14 days)	Through breaks in the skin	Not contagious
<b>Trichomonas</b> <i>Trichomonas vaginalis</i> protozoa	4-28 days (usually 7 days)	Sexual transmission	Until treated
<b>Tuberculosis</b> <i>Mycobacterium tuberculosis</i> mycobacterium	2-12 weeks	Airborne	As long as symptoms are present or until on treatment
<b>Viral Gastroenteritis</b> Various viruses, such as norovirus	10 hours-4 days (usually 1-2 days)	Fecal-oral spread, contaminated food/water	While diarrhea or vomiting is present; can spread for several days after symptoms are gone
<b>Whooping Cough (Pertussis)</b> <i>Bordetella pertussis</i> bacteria	5-21 days (usually 7-10 days)	Droplet/infectious discharges	Until after the third week of coughing, or until after 5 days of treatment