



Grassoline: A Feasibility Study

An Interactive Qualifying Project

prepared for Worcester Polytechnic Institute

May 1, 2010

Authors:

Jared Franklin, WPI 2011

Brennan Caissie, WPI 2011

Advisor:

Robert W. Thompson

Abstract:

This study attempts to quantify the potential benefits and drawbacks of growing and utilizing cellulosic biomass as a biofuel feedstock in Massachusetts. Economic and logistic evaluations will determine the feasibility of creating and maintaining a cellulosic biofuels infrastructure.

Table of Contents:

Background information	3
Mass Balance of Grassoline Process	25
Energy Balance of Grassoline Process	35
Application in Massachusetts	42
Sources	53

The Need For Change

For many years we have heard voices calling for the development and use of alternative energy sources in order to preserve our environment. Partisan political agendas and lack of funding have been to blame for much of the lack of speed with which this issue has been addressed, but we do seem to be making some headway at last. Public knowledge of alternative energy sources has grown thanks to public documentation of various scientific findings and the U.S. government is starting to catch on, too. Recently, \$50 billion in direct funding and \$20 billion in tax credits were allotted to renewable energy research and development through the Obama stimulus package.¹

Much of the public's knowledge about alternative energy has been limited to solar and wind power. While these would be the cleanest energies we could harness, they simply can't compare to coal, oil, and natural gas. The first problem with these two methods is their consistency. Wind energy production can be halted by a calm day. Solar energy production can be thwarted by a cloudy day and during the night it cannot produce. Being able to operate around the clock would ultimately be preferable. Add to that the fact that both are highly dependent on their location; some areas are far windier than others and some get more sunlight than others.

Next we must consider the cost of these power plants. Because of their low energy production, many solar panels or wind turbines would be needed to power an average-sized town. Meanwhile, land consumption becomes an issue for the same reason. Most importantly,

these forms of energy have little practical use with respect to our nation's transportation infrastructure, which is the leading source of pollution and oil usage.

Fig. 1 – Energy cost per kilowatt hour by source

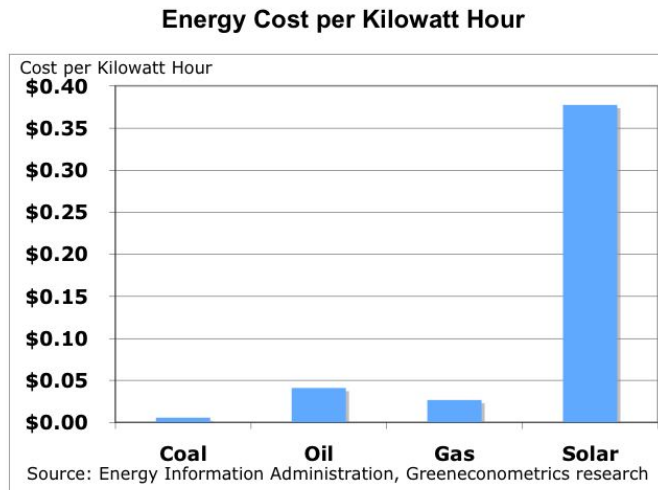

As is clear from Figure 1, solar power is only financially viable with significant tax incentives.²

Ultimately, it comes down to a question of practicality. We must remember that there is a reason why oil's value consistently rises, why we have overlooked its effects on the environment for so long, and why our accumulation of it has dominated our foreign affairs: it gets the job done. We simply could not survive without it as a nation. Petroleum products are the cheapest and most efficient source of electricity, heating, and locomotion.

Fig. 2-Costs and Pollutant Levels of Various Home Heating Methods

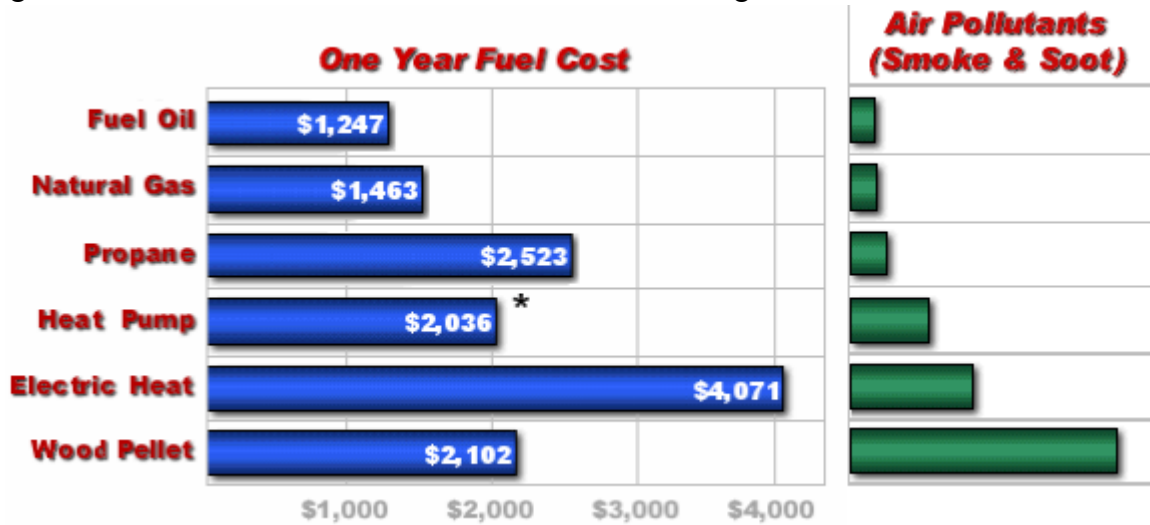

Table 1- U.S. Cellulosic Ethanol Plants⁵

FEEDSTOCK	COMPANY	LOCATION
Abengoa Bioenergy	York, NE	Wheat straw
Abengoa Bioenergy	Hugoton, KS	Wheat straw
AE Biofuels	Butte, MT	Multiple sources
Alico, Inc.	La Belle, FL	Multiple sources
BlueFire Ethanol, Inc.	Irvine, CA	Multiple sources
Catalyst Renewables Corp.	Lyonsdale, NY	Woodchips
Clemson University Restoration Institute	North Chareleston, SC	Multiple sources
Gulf Coast Energy	Mossy Head, FL	Wood waste
Iogen Biorefinery Partners, Inc.	Shelley, ID	Multiple sources
Lignol Innovations, Inc.	Commerce City, CO	Wood
Mascoma Corp.	Lansing, MI	Wood
Mascoma Corp.	Rome, NY	Multiple sources
Mascoma Corp.	Vonore, TN	Switchgrass
Pacific Ethanol	Boardman, OR	Mixed biomass
POET Biorefinery	Emmetsburg, IA	Corn cobs
Pure Vision Technology	Ft. Lupton, CO	Corn stalks and grasses
Range Fuels	Treutlen County, GA	Wood waste
SunOpta Bioprocess LLC/Central Minnesota Ethanol Co-op	Little Falls, MN	Wood chips
Verenium Energy	Jennings, LA	Wood waste
Western Biomass Energy (KL Process)	Upton, WY	Wood waste
Xethanol Corp./Southeast Biofuels	Auburndale, FL	Citrus peels

There are actually many advantages to the use of ethanol over gasoline. Ethanol, at present, is blended with gasoline because of it leaves fewer carbon deposits within an engine than gasoline, so ethanol engines would last longer and break down less frequently. Ethanol also has a rather high octane rating, which means it would burn at a more controlled rate than gasoline and thus be used at a slower pace which increases its miles per gallon. An added bonus is that ethanol engines would not require antifreeze in the winter because of ethanol's extremely low freezing point.⁶

Fig 4- Octane Ratings of Ethanol and Blends of Gasoline⁶



At first glance, ethanol would seem to be the fuel of the future. However, there are several drawbacks to switching over our entire fuel economy to ethanol. First of all, we would need to replace all existing car engines with ethanol-burning engines. This cannot be a rapid process, unless the government provided funding for ethanol engines for all existing cars and outlawed gasoline-burning engines, which is extremely unlikely to ever happen. Therefore, it would be up to each individual to buy an ethanol engine and then pay to have it professionally installed, which is highly impractical. The car manufacturers would also need to switch their

models over to ethanol engines, but they cannot because until ethanol is readily available on street corners, no one will be interested in buying an ethanol-powered car.

Another reason ethanol may take a while to catch on is its heating value. Gasoline has a lower heating value of 116,090 Btu/gallon and a higher heating value of 124,340 Btu/gallon. Compare that to ethanol's rather low 76,330-84,530 Btu/gallon and it is easy to see that gasoline produces far more energy.⁷ In spite of ethanol's greater burning efficiency, its lower energy yield negates some if not all of that advantage.

Cellulosic Gasoline as a Solution

It seems that we as a nation are fated to continue our petroleum dependency long into the future, especially given the recent economic collapse. However, a new technology has presented itself which could potentially solve our fuel problems very quickly. Cellulose has been being converted to ethanol for some time now, but recently more cellulosic biofuels have been discovered. It now seems that not only ethanol, but also most petroleum products such as gasoline, diesel, and even jet fuel can be produced from cellulose.⁸

Tentatively referred to as "grassoline," these products have the potential to revolutionize our fuel economy. First of all, it is a biofuel, and thus converting over to it would stifle air pollution. Secondly, it might eliminate some of the need to import fuel from other countries. Third, there would be no need for construction of the high compression engines required for

ethanol fuel. Finally, the jobs it would produce would be a net gain, since the jobs this business would be making obsolete would be overseas, not here.

The process to reconstruct cellulose into gasoline is not terribly complex. Cellulose is heated in a pressure cooker to 500 degrees Celsius, which causes it to break apart into smaller molecules. These molecules are inserted into a three-dimensional catalyst, which promotes chemical reactions that remove oxygen from the cell rings. The reactions take only a few seconds and when they are over, the producer is left with aromatic gasoline molecules along with some by-products, which are water, carbon monoxide, and carbon dioxide.⁸

Fig. 5- Cellulose-to-Gasoline Conversion using a Catalyst⁸

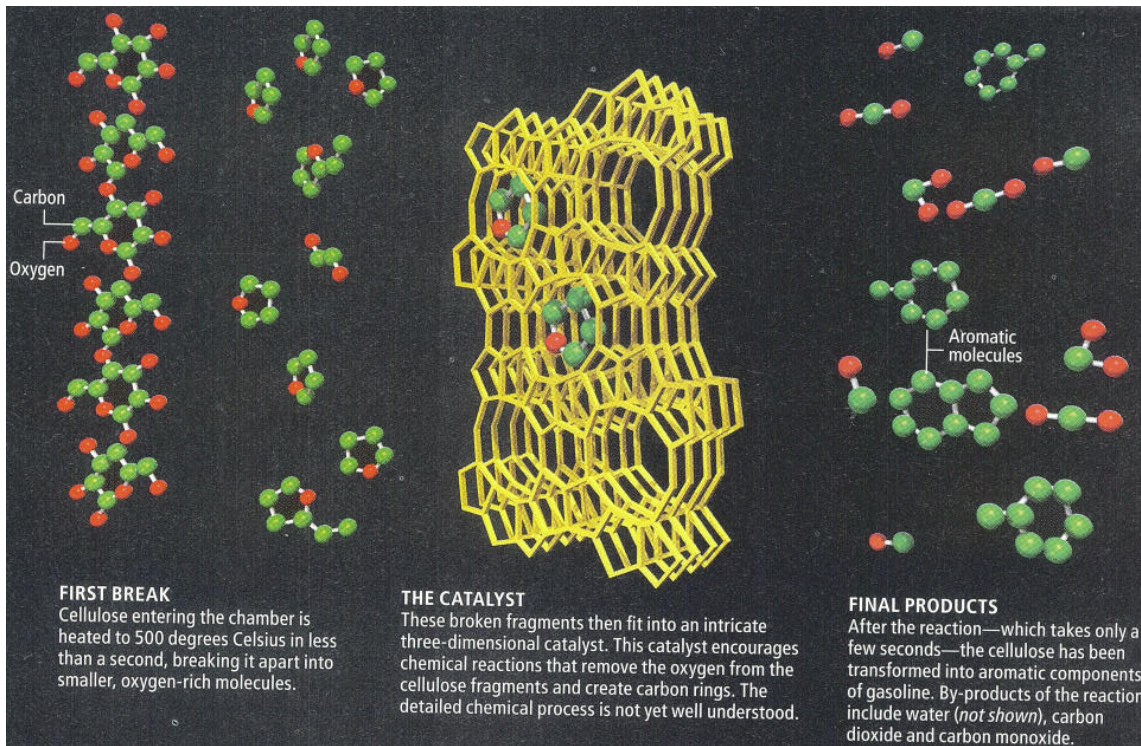

“Grassoline” still has some kinks to be worked out, as it is a fairly new process. Research is being done to gain a better understanding of the catalyst phase. Also, certain individuals have suggested using a different method incorporating Q-microbes, a micro-organism only recently isolated, which supposedly has the ability to directly transform cellulose into gasoline, meaning that the process could be done with fewer steps and perhaps for less money.

Conveniently, a cellulosic gasoline plant would be easily converted into a cellulosic ethanol plant. This means that if we embrace this technology, later on when we as a society finally recognize the advantages of an ethanol-based fuel economy, it will be a much cheaper and quicker conversion for us to make than it would be right now. For the time being, cellulosic gasoline could be a very good choice for us.

To fuel cellulosic ethanol and gasoline plants, you of course need a source or sources of cellulose. Cellulose is found in all plant matter, and so oftentimes plant waste like corn husks and fruit peels are used. Another possibility is the use of energy crops, plants specifically cultivated so they can be reaped for their cellulose and replaced with a new crop planted with the same intentions. Usually these crops are chosen for cultivation by their growth rate and size upon reaching maturity. The quicker and bigger they grow, the more efficient they are for fuel conversion. Either choice is fairly inconsequential to the environment. The important thing to realize about cellulosic waste material is that it is not necessarily in great enough abundance to be converted for a substantial amount of our fuel, as shown in the section Application in Massachusetts. On the other side, feedstock requires land usage and thus requires a lot of start-up funding and planning.

Cellulosic waste materials can come from a variety of sources. The most abundant here in the United States is agricultural waste. Agricultural waste can come in a variety of forms: corn stover, plant husks, plant stalks, inedible leaves and vines. Ultimately the aim of agriculture is to cultivate a plant but only for a specific part or parts. The rest is simply waste which is used to renew the soil; however, not all of this waste is needed to do so, and thus much of it could be converted to fuel.

Forest waste products are also quite plentiful in the United States. Much like agricultural wastes are acquired from farmers, forest waste is acquired from lumber mill workers. Bark, wood chips, sawdust, small branches, roots, leaves, pine needles, and pine cones are all things lumber mills have little use for that could be used for fuel. The paper industry also tends to generate a lot of forest waste.

Various organic waste products can be used for cellulosic fuel conversion as well. Citrus peels, banana peels, potato skins, moldy or stale bread products, freezer-burned vegetables, onion skins, and many other household wastes can be harvested for their cellulose. In addition, waste paper could potentially be used as well, since it is derived from trees, though much of this waste is already recycled into more paper and thus is not totally useful other than for fuel. One of the most exciting prospects is solid waste conversion: for many years we have known it is possible to derive fuels such as methane from solid waste, but it turns out one of the chief ingredients in our fecal matter is cellulose. This is because our digestive system lacks the capability to digest cellulose, and so it is directly excreted as waste. A two phase process could be used to harvest methane and then cellulose from our solid waste. Toilet paper would also obviously be a great source of cellulose.

Fig. 6 – Biomass availability⁸

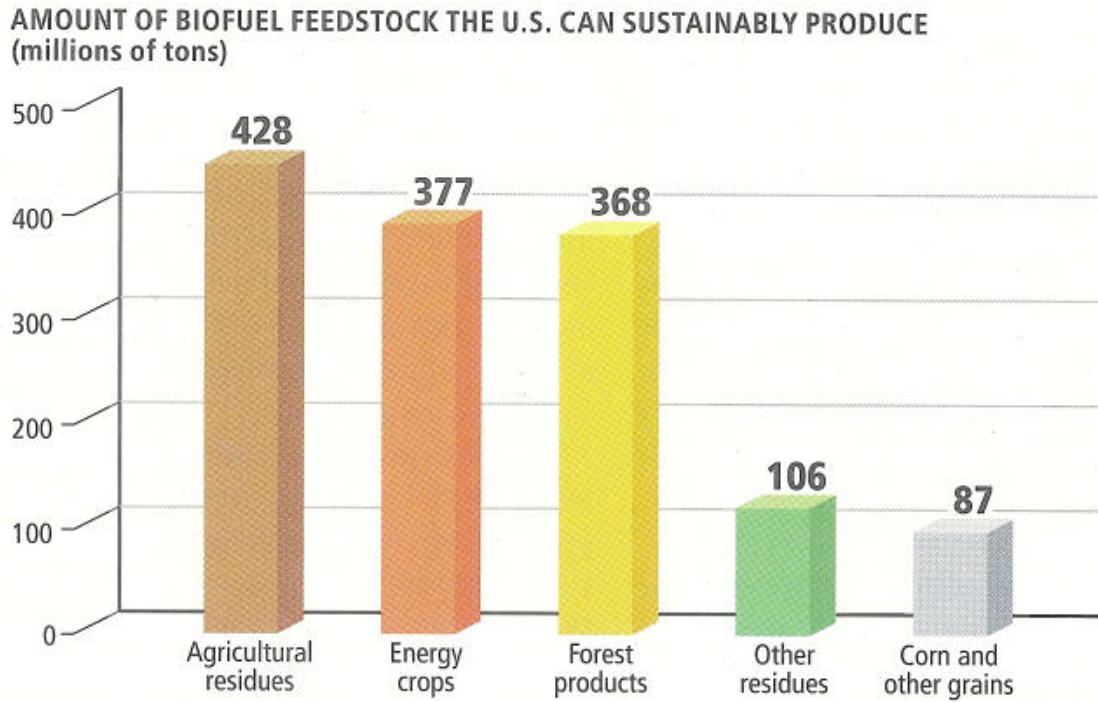
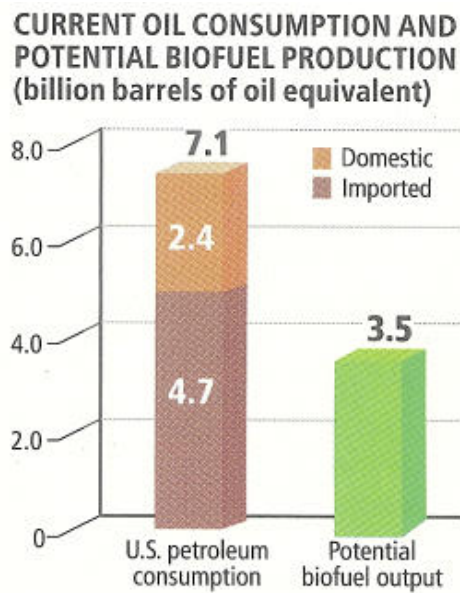

Fig. 7 – Oil consumption compared to biofuel production⁸



The potential biofuel output equals the peak U.S. oil production, which the country hit in 1970.

Alternative Methods

The major methods for commercial production of biofuels from cellulosic biomass are concerned primarily with breaking down the cellulosic material to concentrate the energy in the feedstock. In addition to enzymes, some bacteria can be used to decompose the plant matter and ferment ethanol or energy rich products. One company that has commercialized this method is Qteros, which uses a bacteria of the genus *Clostridium* to break down the cellulose and produce ethanol. This method has the potential benefit of replacing the addition of enzymes, which can be costly to produce, as the microbe releases its own enzymes to break down the feedstock and ferment it into a usable form.²²

Another method of extracting liquid fuel from biomass is the use of pyrolysis. This involves the heating of the feedstock until the cellulose breaks down and liquid and gas products are released. There are several variations in method for pyrolysis, but common between them is that the end product quality and energy density are improved when dilution due to circulating gases or fluids is lowered and when the heat is applied quickly and evenly. Pursuant to this, the greatest yields are reported using flash pyrolysis, in which the biomass is first ground or otherwise greatly reduced in average particle size and subjected to a circulating high heat. Often there is a heat carrying fluid or gas that is circulated to keep the temperature high and to reach all particles of feedstock. Metal beds are also used with particulate feed to spread heat. These metal parts can be rotated or moved rapidly to facilitate even and quick heating, though as with the moving gases or fluids there is mechanical difficulty involved. Sand is sometimes in conjunction with a gas to provide a fluid heat, though this is of even greater complexity in process design.

However, when these gases or fluids are introduced the final products energy density is lowered and the result is often unsuitable as a direct ethanol replacement. Additionally, with greater mechanical and process complexity, as well as high heat required for higher density yields, the energy required to produce this bio-oil can become high and endanger the overall efficiency of production. This problem is somewhat abated by using some of the product to heat or power the production mechanism, which can render the process more efficient. ²³

Fig. 8- Yield Results of a Study in Fast Pyrolysis of Corn Components²³

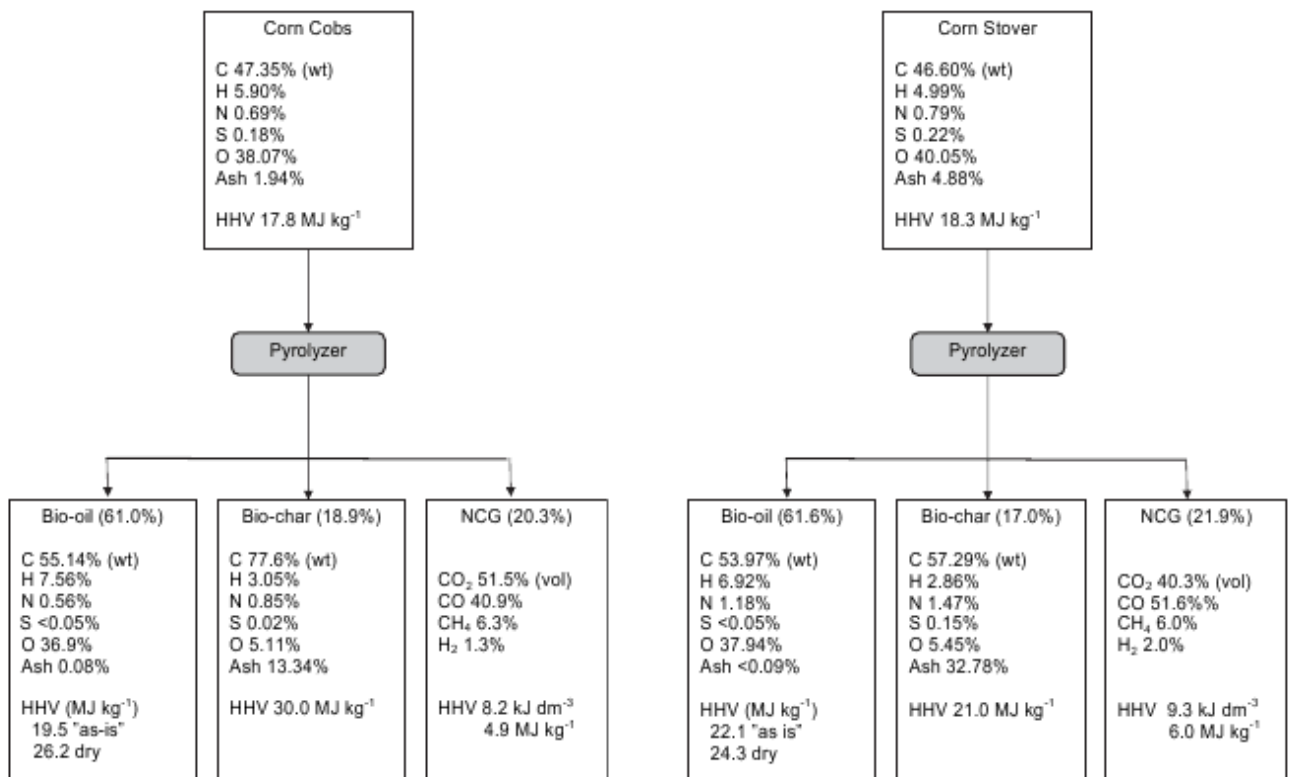

Fig. 1 – Elemental analysis (dry basis) and high heating value (wet basis) of corn cob and its pyrolysis products (average of two pyrolysis experiments).

Fig. 2 – Elemental analysis (dry basis) and high heating value (wet basis) of corn stover and its pyrolysis products (average of two pyrolysis experiments).

Pyrolysis produces several different oils, gases, and solids. The solid remainder of the process, termed bio-char closely resembles coal, in that it is primarily carbon and contains many of the minerals left in the plant matter before being broken down. Accordingly, the char can be used on soil to improve fertility as removing all the plant material leaves the earth depleted of necessary minerals. It also has the potential of being burned for energy as coal is currently used in power plants across Massachusetts.

The oils produced are primarily sold for use as a fuel, though the energy densities are typically lower than ethanol and more closely resemble crude oil and as such are not suitable as a drop-in fuel replacement. It can, however, be further refined after pyrolysis to make them more suitable for commercial use. The gases are sometimes collected as a commercial energy product but are more frequently recirculated through the pyrolysis machinery to distribute heat and keep the biomass particles homogenized. All three can be used to produce the heat required for the process, if the yield and reactor allow for it.

Fig. 9- Pyrolysis Reactor with Recirculated Gas²⁴

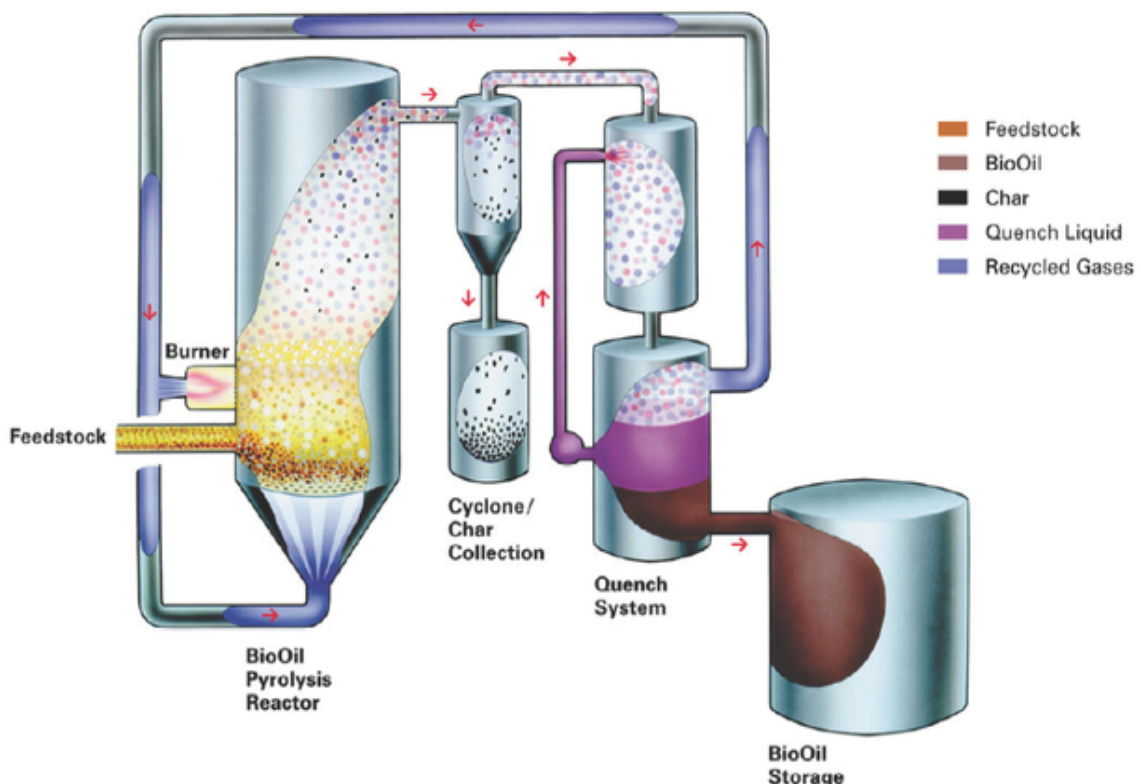

Energy Crops

Energy crops are likely to become a huge industry in the United States. Currently, a variety of potential energy crops grow here naturally. Switchgrass is one of the most popular energy crops in use, and grows naturally in much of North America, but can grow in almost any climate found in the continental United States. A cousin of switchgrass known as Miscanthus is already grown in great quantity in Europe as feedstock for biofuels, and has been cultivated in some parts of the United States as well.

Switchgrass boasts a number of advantages over other crops with respect to viability as an energy crop. Switchgrass takes about one season to grow to its full height, which is a very short time period in comparison to other energy crops. Switchgrass typically lives for about three years and then must be replanted. There are two types of switchgrass, which are meant for different soil types. One kind requires less nutrition and water and grows to five or six feet by maturity. The other has greater demands but can grow as tall as twelve feet high. Generally the shorter crop is considered the better alternative because of the extremely low maintenance required to grow it. This strain of switchgrass was grown by students and professors at the University of Auburn on test plots and was found to produce over ten tons of biomass per acre with each crop rotation. However, these results were found under ideal growing circumstances and thus may not accurately depict large-scale commercial yields.⁹

Fig. 10- Switchgrass Nearing Maturity¹⁰



Fig. 11- Switchgrass Growth Locations in the US¹¹

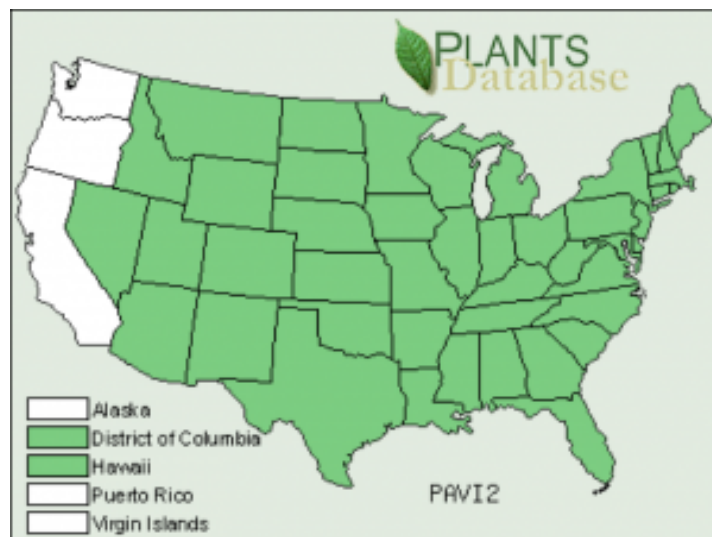

Switchgrass' cousin Miscanthus is also a viable energy crop. Currently grown in ten European countries for biomass needs, this plant has well documented properties. It is very similar to the larger strain of switch grass, which of course means more work to grow it and

more yield to harvest. On the downside, Miscanthus is less sturdy than its cousin and is highly susceptible to the elements, particularly frost.¹²

In addition to grasses, there are a number of potential trees to be used as energy crops. One example would be poplar trees. Poplar trees are rather large and known for their bulbous catkins. In a feat of modern biotechnology, new breeds of “hybrid” poplar trees have been created; these breeds can grow up six to eight feet per year, reaching a maximum height of forty to fifty feet within about four to five years. Since it buds catkins yearly, these could be used both to gain seeds for the next generation and for a yearly biomass harvest until the tree has reached its maximum height. A major advantage of hybrid poplars is their tolerance of varying soil types as well as droughts, mimicking some of the strengths of switchgrass.¹³

Fig. 12- Fully-grown Poplar Tree¹³



Fig. 13- Polar Growth Locations in the US¹³



Another tree that has great potential is the willow tree. Willow trees produce a great deal of biomass due to their long, drooping canopy of leaves. Not only that, but willows have an extensive root system, which ultimately translates to there being even more biomass to be harvested from this plant. They can grow at an alarming rate of up to ten feet per year, growing for only about two years until they reach their maximum height of about twenty feet.¹⁴ This is an extremely fast production period for a tree.

Fig. 14- Weeping Willows¹⁴



Fig. 15- Willow Growth Locations in US¹⁴



Energy Profile for the State of Massachusetts

Our analysis of the efficiency and practicality of cellulosic gasoline is centered around the state of Massachusetts, rather than the entire United States. The state of Massachusetts

consumes energy from diverse sources. Electricity is generated through coal, oil, natural gas, nuclear, hydroelectric, and other sources. In August 2009 the state produced 4.26 million megawatt-hours of electricity, with the major sources being natural gas, coal, and nuclear. Currently renewable energy sources outside of hydroelectric make up only 2.58% of the total generation.¹⁵

Table 2- Electricity Energy Production by Source¹⁵

Energy Source	Energy Generated (thousand MWh)	% of total
Natural Gas	2665	62.26%
Coal	868	20.38%
Nuclear	500	11.74%
Renewables	110	2.58%
Hydroelectric	81	1.90%
Petroleum	44	1.03%

In 2007 Massachusetts produced 98 trillion Btu of energy while consuming 234 trillion.¹⁵ This energy deficit gives great opportunity for additional sources of energy generation. Sources of particular interest for offset by renewable or cleaner alternatives are coal and petroleum, as they contribute the largest share of energy and pollutants. Massachusetts imported 125.8 million barrels of petroleum in 2007. The majority, 70.6 million, went to motor gasoline, an area where bio-fuels are hoped to be used.

As a northern state, Massachusetts has significant demands during the winter for heat. Approximately 40% of homes use heating oil, which is imported in large quantities.¹⁵ This could be supplanted by bio-fuel or burning a cellulosic biomass grown in-state to reduce delivery costs

and increase overall efficiency in addition to the benefits of being renewable and possibly cleaner. Heating oil consumption is, predictably, heaviest during winter months to a degree which would possibly necessitate a method of effective storage for any replacement fuels during the summer so that the production could be kept even during the year. Massachusetts, along with much of the U.S. Northeast, is vulnerable to distillate fuel oil shortages and price spikes during winter months due to high demand for home heating. Like many other states, Massachusetts also does not currently have any natural gas storage sites and relies on other storage facilities to meet high demands, which include import from overseas through a port near Boston and a pipeline from the Gulf Coast and Canada.¹⁵ These long distances increase the chances of residents being cut off from supplies of heating oil in inclement weather, disaster, or emergency. In-state production and storage of an alternative fuel could not only lessen transportation costs but also increase reliability.

The state has a long history of agriculture with significant amounts of arable land. Much of the state is forested and large areas have low population density. Government data indicates that 46% of the state's land is devoted to forest, with another 7% parkland which is also mainly forested¹⁶. Approximately 4% of the land is cropland and less than 1% is pasture. The large amount of forested land makes it possible to practice fuel forestry, growing and harvesting fast-growing trees or shrubs for use as bio-fuel feedstock.

Fig. 16- Energy Distribution in the State of Massachusetts¹⁵

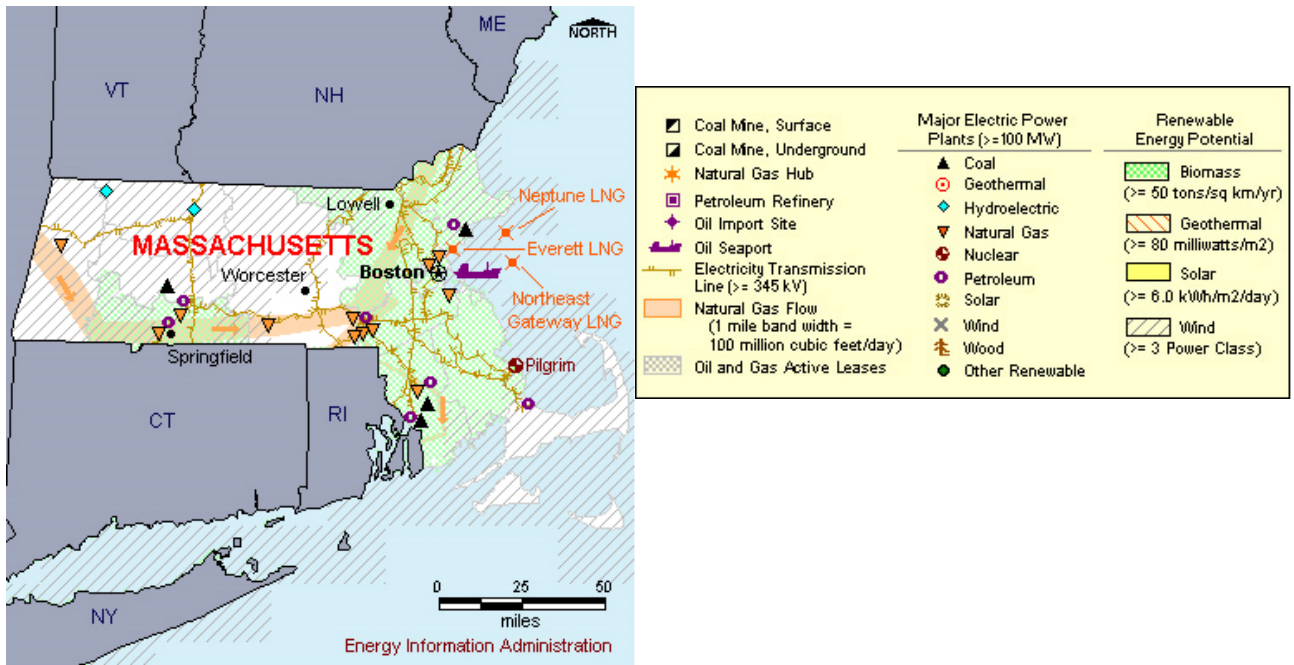

Common feedstock proposed include Poplar, Switchgrass, and Willow, which are grown for 2-5 years before being harvested. These crops are “coppiced,” in which they are cut repeatedly at ground level so they produce many shoots which grow rapidly in the subsequent years. The tree species Alder, Ash, Birch, and Sycamore can be used in a longer crop rotation of 8-20 years. Burning trees for energy releases carbon into the atmosphere, but in a sustained cycle the amount released is significantly less than the amount released by fossil fuels over a lengthy period. This is due to the carbon being absorbed from the atmosphere into the tree which is released upon burning. Burning fossil fuels releases carbon that had been sequestered for millions of years in an unsustainable way.

Fig. 17¹⁷

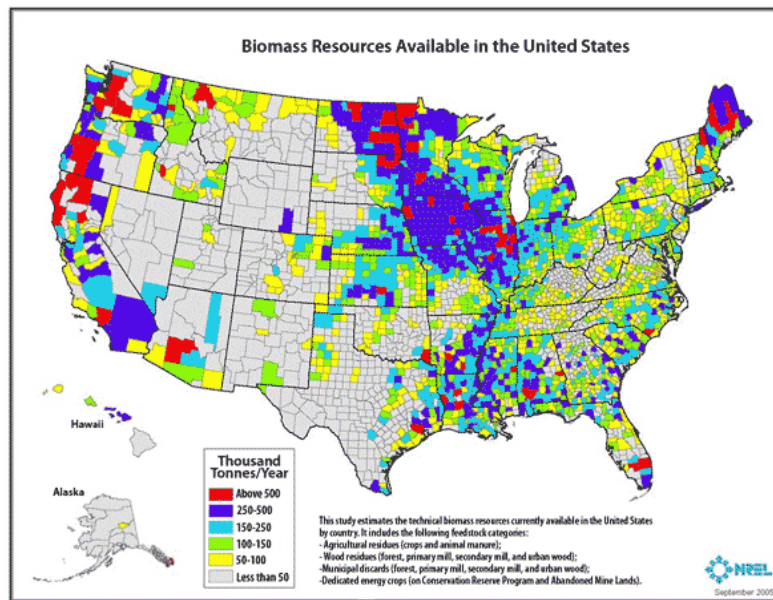

In comparison to nearby states Massachusetts has similar biomass growth potential with only northern New Hampshire and Maine having a wide margin of superiority. It is within average conditions on the eastern coast, and far ahead in comparison to large areas of the Midwest.¹⁷

Major benefits of using Poplar and Willow include their high energy yields, fast growth, oxygen production, and that their natural range includes Massachusetts. This would limit the dangers of introducing an invasive species to the state or damaging the local ecosystem. Additionally as a northern state, Massachusetts has several winter months with an average temperature below freezing, which severely limits the diversity of plant life. Miscanthus has been discounted as a viable feedstock due to its vulnerability to frost. Growing trees for energy

use also makes use of the extensive forestation present in the state and does not supplant food crops in current farmland. Also, trees are able to be harvested despite a ground covering of snow, while grasses or small shrubs would be covered completely and not worth extracting.

One drawback to using trees as a source of biomass could be the amount of water needed to grow trees in managed forestry, though the widespread forestation suggests that water availability is sufficient. If it becomes more financially rewarding to use land for energy forestry than for food crop production, land owners may convert their land to an extent that food production becomes problematic. This issue is however much less severe when forest products are used as feedstock as opposed to established food crops like corn.

Of the 6,755,200 acres in Massachusetts, 3,126,000 are forest-use land¹⁶. This forest land is further divided into 74,000 acres of federally-owned land and 3,052,000 acres of non-federal land.¹⁶ For sufficient feedstock supply, it is likely that much of this land would need to be clear-cut and reforested.

Recent popular sentiment has become favorable to alternative energy and sources aside from the traditional coal and petroleum. In accordance, state legislature has passed provisions to increase production of cleaner and more sustainable fuels. In July 2008, Massachusetts adopted a renewable portfolio standard requiring renewable energy to account for 15 percent of total electricity generation by 2020 and 25 percent by 2030¹⁵. As the current renewable energy production is much below this target, there is ample opportunity for growth. Subsidies, government contracts or leases to government land on favorable terms are likely necessary to

spur development of a bio-fuel industry in which the initial costs may be prohibitively high and unable to compete with the well-established fossil fuel industry.

The Massachusetts Department of Energy Resources is funding the MA Sustainable Forest Bioenergy Initiative, which is providing research and development on forest management and market infrastructure needs as well as enable the state to provide resources to develop the biomass supply market¹⁸. This program is supported by the U.S. Department of Energy and the Massachusetts Technology Collaborative Renewable Energy Trust. The state is also planning to grant cellulosic biofuels a tax exemption. The Massachusetts Advanced Biofuels Mandate also encourages the production and commercialization of biofuel production. These initiatives indicate a significant commitment on behalf of state and federal governments to explore alternative sources of fuel and move to a sustainable form of energy production.

“Grassoline” Mass Balance

The first step in this investigation is to discern the conversion rate between plant matter and gasoline. The process mentioned in the “Grassoline” article remains rather undefined; no data was found with regards to cellulosic mass converted to gasoline. However, there is plenty of data available with regards to cellulosic ethanol. It was decided that using these values in conjunction with another process which converted ethanol into gasoline would yield similar mass conversion data to whatever the process of direct conversion from cellulose to gasoline might yield. This assumption was made with the laws of mass in mind. On the other hand, energy

requirements for the direct conversion method would likely be less, which must be considered later on.

The first of two steps in this process is to convert plant matter into ethanol. Bruce Dale, a co-author of the original “Grassoline” article, co-wrote two articles in a journal called “Biofuels, Bioproducts, and Biorefining” from which this first step is taken. Seen below, the system yields ethanol and hydrogen gas from feedstock:

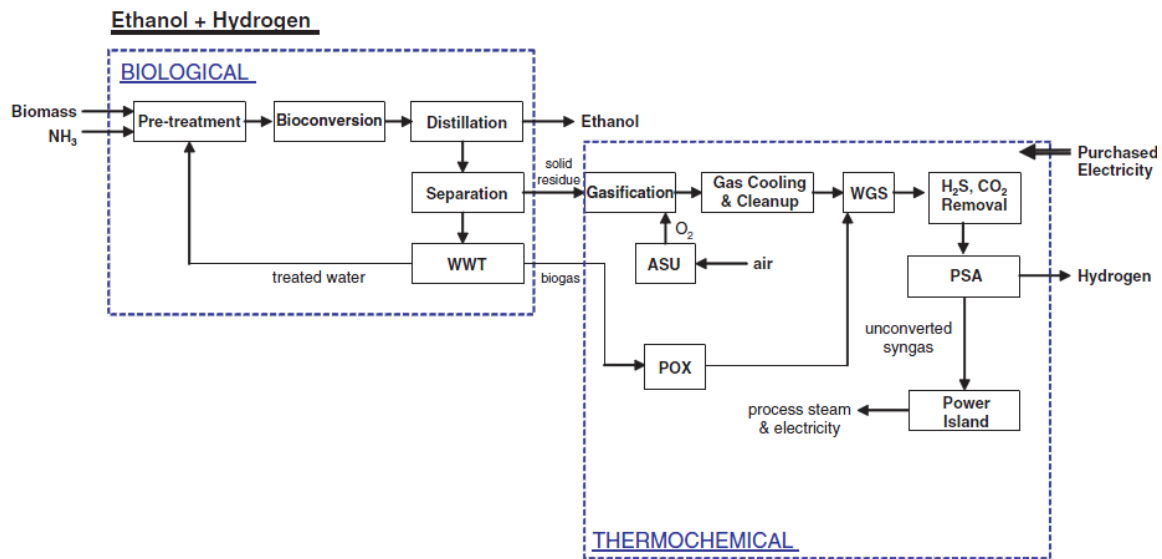

Fig. 18 - Example of Biomass-to-Ethanol System with Hydrogen Gas Byproduct²⁵

The hydrogen gas produced could actually be used to provide some, if not all, of the needed energy to keep the system working. Either that or it could be combined with nitrogen gas to make ammonia to be used in the pretreatment step of the system. Another potential process yields synthetic natural gas:

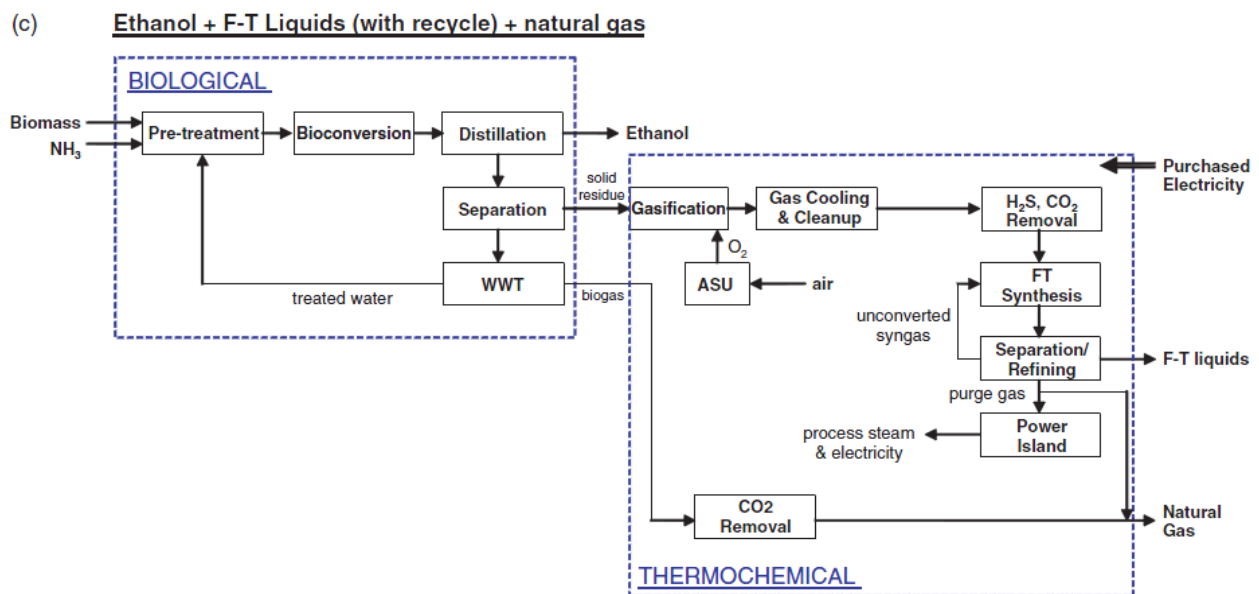

Fig. 19 - Example of Biomass-to-Ethanol System with F-T Liquids and Natural Gas

Byproduct²⁵

Such a system design would be highly lucrative as well as environmentally friendly; some CO₂ is released during cellulosic ethanol production regardless, but at least in this system it would be harvested and reused rather than being allowed to enter the atmosphere. It is likely this system would be a better method of self-sustaining the process, since natural gas tends to be

easier to burn in a controlled manner than H₂.

For the second step, ethanol is converted into gasoline and water.

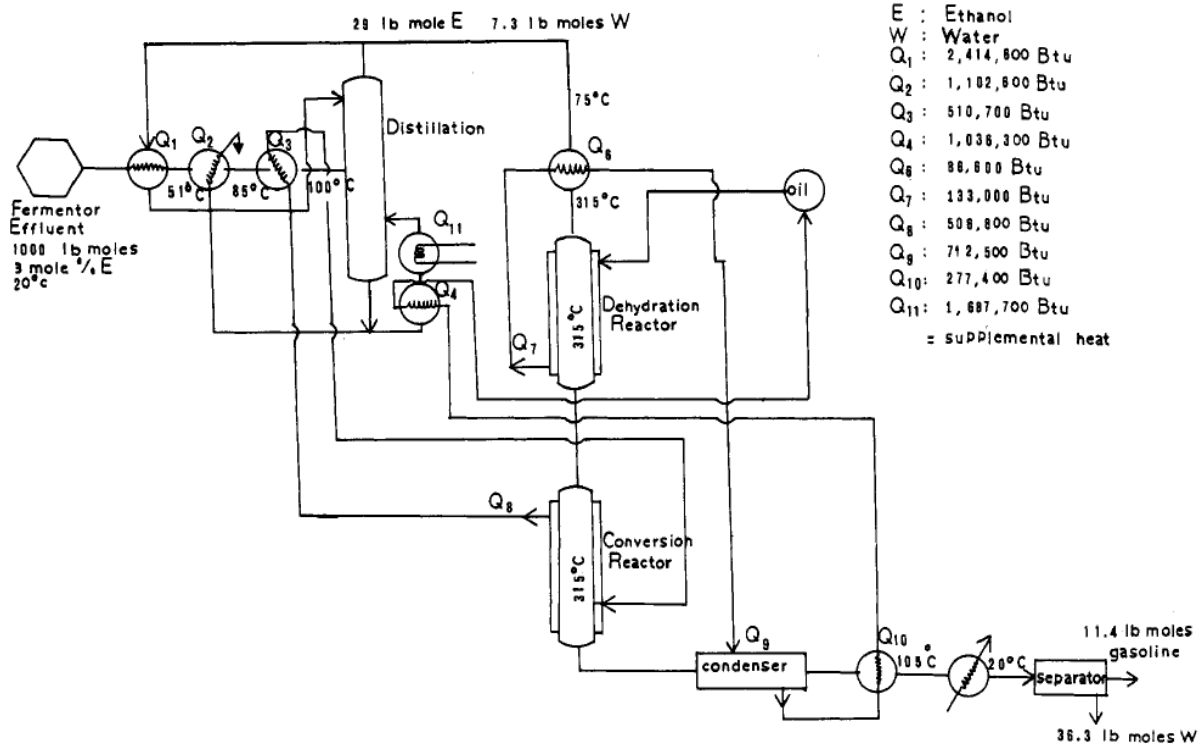

Fig. 20 - Aqueous Ethanol-to-Gasoline System²⁶

With both of these systems in place, mass and energy balances can begin to be formulated. Unfortunately, because the conversion rates differ for various carbohydrates in plant matter, and each strain of plant life has varying mass fractions, it is hard to decide on a conversion rate between feedstock and ethanol. Luckily, there is input/output data readily available from cellulosic ethanol plants. A plant in Canada run by the Iogen Corporation reports a conversion of 20-30 metric tons of feedstock to 5,000-6,000 liters of ethanol per year.²⁷ These values can be averaged to yield 25 metric tons of feedstock to 5,500 liters of ethanol. The

density of ethanol is 0.789 g/cm^3 . The following can thus be derived from this information:

$$25 \text{ tons} = 25,000,000 \text{ g}$$

$$5,500 \text{ L} = 5,500,000 \text{ cm}^3$$

$$5,500,000 \text{ cm}^3 \times 0.789 \text{ g/cm}^3 = 4,335,900 \text{ g}$$

$$4,335,900 / 25,000,000 = 0.173$$

A little over 17% of the matter put into the system actually becomes ethanol. Next the ethanol-to-gasoline conversion rates must be found. In the paper cited, 1000 lb-moles of 3% molar ethanol solution is input and 11.4 lb-moles of gasoline along with 36.3 lb-moles of water are released. One lb-mole is equal to 453.6 moles. Therefore, the input can also be written as 453,600 moles of 3% molar ethanol solution. Since only the amount and molarity of the solution are known, the actual amount of ethanol must be calculated from these figures.

$$\text{Molar mass of ethanol: } 46.07 \text{ g/mol}$$

$$453,600 \text{ mol} \times 0.03 = 13,608 \text{ moles}$$

$$13,608 \text{ mol} \times 46.07 \text{ g/mol} = 626,910 \text{ g}$$

Now the mass of ethanol required for input into this system is known. Next it is necessary to find the output of gasoline in terms of mass.

$$\text{Molar mass of gasoline: } 114 \text{ g/mol}$$

$$11.4 \text{ lb-moles} \times (453.6 \text{ moles/l lb-mol}) = 5171 \text{ moles}$$

$$5171 \text{ moles} \times 114 \text{ g/mol} = 589,490 \text{ grams}$$

Since both of these substances are liquids and thus will likely be measured in liters, their specific volumes should be applied to find the volumetric amount of ethanol required and gasoline produced.

Specific Volume of Ethanol: 1.267 mL/g

$$626,910 \text{ g} \times 1.267 \text{ mL/g} = 794294.919 \text{ mL} = 794 \text{ L of Ethanol}$$

Specific Volume of Gasoline: 1.33 mL/g (approx.)

$$589,490 \text{ g} \times 1.33 \text{ mL/g} = 784020 \text{ mL} = 784 \text{ L of Gasoline}$$

$$784 \text{ L} / 794 \text{ L} = .987$$

Now that all major parts of the two-step system are accounted for, general rates can be created to show relation between the input of plant matter and the output of gasoline.

25 tons plant matter : 5,500 L ethanol

$$5,500 \text{ L} \times .987 = 5429 \text{ L gasoline}$$

$$5429 \text{ L} / 25 \text{ tons} = \mathbf{217 \text{ L gasoline per ton of feedstock}}$$

1 metric ton=1,000,000 grams

$$217,000 \text{ mL gasoline} \times .75 \text{ g/mL} = 162,750 \text{ grams}$$

$$162,750 \text{ g} / 1,000,000 \text{ g} = .163$$

So the actual conversion rate is 217.154 L of gasoline per metric ton of feedstock. About 16.3% of the biomass invested becomes gasoline. The rest is either unusable (such as lignin

which can be burned for extra fuel) or becomes byproducts (such as hydrogen gas which can also be burned).

The next important step in understanding this energy process is to analyze some properties of the feedstock. On average, switchgrass yields about seven tons (English units) per acre about every three years to grow to its full length.⁹ To convert to metric tons, this figure should be multiplied by 2205 lb/2000 lb, which gives 7.72 metric tons of biomass.

$$7.72 \text{ tons feedstock /acre} \times 217 \text{ L gasoline/ton feedstock} = \mathbf{1675 \text{ L/acre}}$$

For each acre of switchgrass, 1675 liters of gasoline can be harvested every 3 years. It could thus be said (since switchgrass grows 1/3 of its maximum height yearly) that annually an acre could yield 558 liters of gasoline.

Fig. 21 - Mass Fraction Table of Switchgrass²⁵

Component	Mass Fraction
Cellulose	0.3236
Hemicellulose	0.2575
Soluble carbohydrate	0.0484
Glucan	0.3236
Glucan (soluble)	0.0382
Xylan	0.2158
Arabinan	0.0290
Arabinan (soluble)	0.0011
Galactan	0.0097
Galactan (soluble)	0.0091
Mannan	0.0029
(Total carbohydrate)	0.6294
Uronic acid	0.0186
Lignin	0.1984
Protein	0.0952
Ash	0.0389
Acetate	0.0195
TOTAL	1.0000

Currently, there are 14,000 acres of land in Massachusetts considered “idle” by the State government.¹⁶ In addition, there are 152,000 acres of farmland and 30,000 acres of pasture. If this land was either bought up and cultivated with switchgrass, or if the farmers who owned the land simply switched their focus to growing switchgrass, Massachusetts could produce enormous amounts of biomass. If half this land was used for the purpose of growing switchgrass, the State

could output over 50 million liters of gasoline per year, which in barrels would be more than 314,000 barrels. However, Massachusetts currently uses up about 68 million barrels of gasoline each year.¹⁵ Therefore, this much cultivated land would still only cut yearly gasoline needs by 0.5%. Another possibility would be partial destruction of forests and recultivation with switchgrass or poplar trees in the cleared areas. This would provide a good deal of biomass immediately while investing for the next generation of biomass harvesting.

The findings of these calculations may seem disheartening, as they appear to impact our state's annual gasoline use so little. However, it is important to note that Massachusetts is a rather small state that is heavily forested and populated. Therefore, there are not many flat, open plains to grow switchgrass on and at the same time we use up much more gasoline than some other states due to our large population and urban sprawl. It is safe to say that this technology is not as viable in Massachusetts as it would be in other states, particularly states in the central United States that are mostly flat and undeveloped. Vast tracts of land could be bought cheaply there for switchgrass cultivation, as switchgrass has very low demands regarding soil fertility for growth and since there are fewer forests and cities in the way. Those states would likely be able to support themselves fuel-wise if such an approach was taken.

Biofuels are currently still rather expensive in comparison to orthodox methods of fuel harvesting and refining. This is mostly due to the rather low ethanol yield from biomass, with only about 17% of all mass being converted to ethanol. On the bright side, there are several different processes that produce useful byproducts, including Rankine power or even synthetic natural gas.²⁵ These by-products could of course be used to sustain the reactions with little to no necessary purchase of electricity of fuel from other sources. However, the lignin, which is

removed from the biomass during the pre-treatment phase, generally is plentiful enough and burns well enough to keep the system powered without additional energy. Thus the reactive byproducts could wind up being a bonus source of income. For this reason, the chief price of biomass-to-ethanol conversion is the price of feedstock.

An important aspect to investigate in this scheme is the role and properties of the zeolite catalyst (ZSM-5) used in ethanol-to-gasoline conversion.²⁶ Zeolites are a variety of aluminosilicate minerals which are microporous. The micropores within the zeolite catalyst only allow molecules of specific size and structure to pass through them, such as gasoline. Ethanol molecules are small, so with the right combination of heating and pressure-treating, ethanol will pass through the zeolite pores and be converted to aromatic gasoline molecules as long as the correct reagents are present in the system. The cost-effectiveness of zeolites is relatively high because zeolites are not actually reactive compounds in the system, but rather structural catalysts, and they do not undergo any chemical change per usage. Also, because they are aluminosilicates, they tend to stand up well to heat and pressure. Over time though, the structure may begin to wear down due to interaction with water molecules, so overall the zeolite catalyst does need to be replaced, but will last for many conversion cycles. ZSM-5 is not particularly expensive, as it only requires SiO_2 , Al_2O_3 , and a temperature of 150-220°C to synthesize.²⁹ Overall, the ethanol-to-gasoline process does not pose any great financial burdens except the cost of feedstock cultivation and harvesting. However, unlike the cellulose-to-ethanol conversion, no useful byproducts are created in this process, and thus a good strategy would be to use the hydrogen gas, Rankine power, or natural gas produced in the first step to provide energy for the second step.

“Grassoline” Energy Balance

The most important measure of the cellulose to ethanol process is its energy efficiency. By comparing the usable energy produced to the energy invested we can determine whether this is a feasible method of fuel and energy production.

In regards to the energy investment, it is important to make the distinction between energy sources naturally provided and energy invested by human effort and fuel or electricity expenditure. Including the solar energy gathered by the plants before harvesting as an input energy drastically affects the process efficiency. Some process studies include this as an energy cost, though most consider it negligible as the energy is essentially “free.” Much debate is given to the boundaries of the systems considered. Some studies go as far as to include the food the farmers eat as an energy input to the system and the estimate the cost of machinery at the price of a new unit without taking into account its usable lifetime or resale value.

Another factor affecting the overall energy efficiency of the conversion process is the use of byproducts of the cellulose to ethanol process as an energy source. The lignin and other plant materials which are not readily broken down can be burned to provide heat or electricity for the process. This burnt byproduct can provide all of the energy needed by the ethanol production facilities. Gas, solid, and liquid fuel that is not considered a viable product can often be likewise utilized as an energy source.

The Department of Energy evaluates the net energy of ethanol on four criteria²⁹:

- Amount of energy contained in the final product
- Amount of energy directly consumed to make the ethanol
- Quality of the resulting ethanol compared to the quality of refined gasoline

- Amount of energy indirectly consumed

The majority of studies of the energy gain and expenditure of these processes show a net gain.

Comparing the publication dates and efficiencies shows a trend of improving efficiency over time.

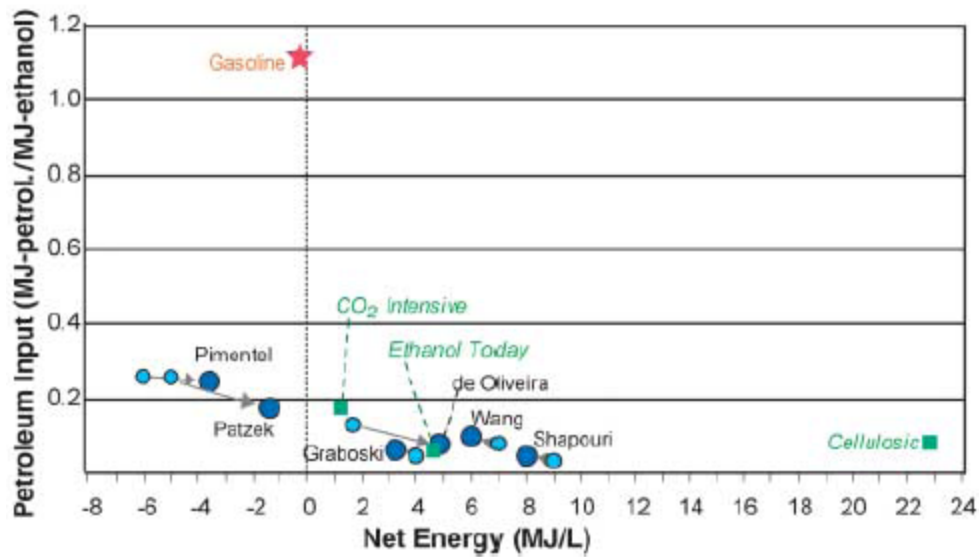

Fig. 22 - Energy output vs petroleum input as reported by several studies

In the graph above the results of several studies of net energy of cellulose to ethanol processes are plotted against the energy in MJ of petroleum per energy in MJ of ethanol. The *Cellulosic* data point on the graph represents a projection of where this technology could be with substantial development and investment in a large cellulosic ethanol infrastructure. *Ethanol Today* is a synthesis of several recent

studies of current process efficiencies. *CO₂Intensive* refers to a plan using corn shipped across the country from Nebraska to ethanol production facilities and is the least efficient method of production. The smaller circles represent reported data and larger circles are adjusted values that use the identical system boundaries. These boundaries include items like energy requirements and costs for farm equipment and growing the feedstocks, the value of byproducts, and transportation or other incidental costs.³⁰

The range of energy balance values is substantial, though commonly accepted values show a energy output/input ratio as being positive and between 2 and 10. Pimental and Patzek are consistent outliers in energy studies, and their results are often contested by other researchers.³¹ Consensus hold that the ethanol produced from cellulose is a net energy gain.

The only study to evaluate the energy balance using a commercial sized plot of cellulosic feedstock (10 Switchgrass plots of 3-9 ha) found an energy balance of 5.4, in a ratio of Joules output divided by Joules input³². The study included data from five years of managed plots and showed a marked increase in net production from year to year. The energy balance was calculated assuming lignin remaining after fermentation was burned to provide an energy input to the system. The study also used an assumed value of 0.38 liters of ethanol produced per kilogram of harvested biomass³².

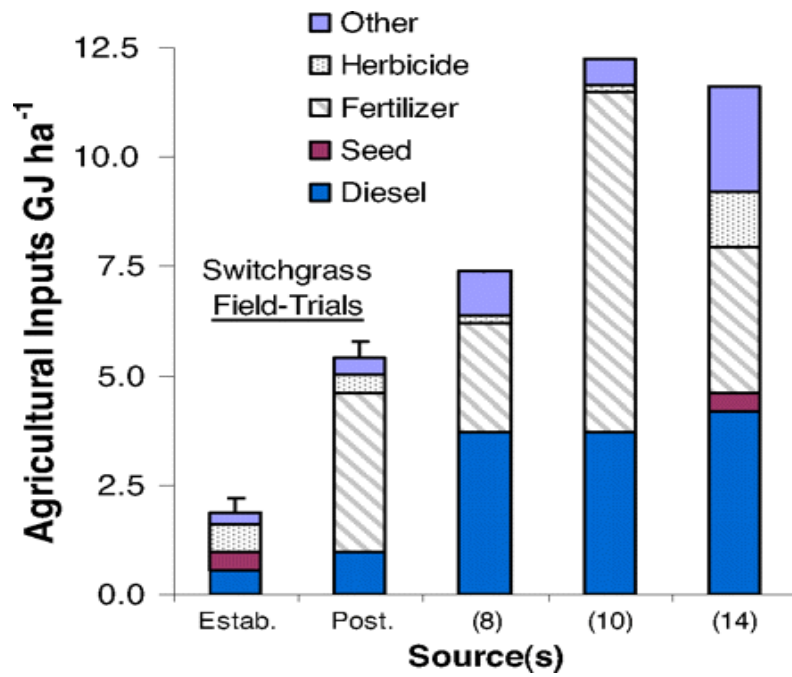

Fig. 22 – Energy inputs for growing switchgrass

The study found that the agricultural energy input was significantly lower than the results of previous small-scale studies. In the graph above the energy inputs of the establishing first year, the post-planting harvesting years, and the estimates of the smaller scale studies (8, 10, and 14.)

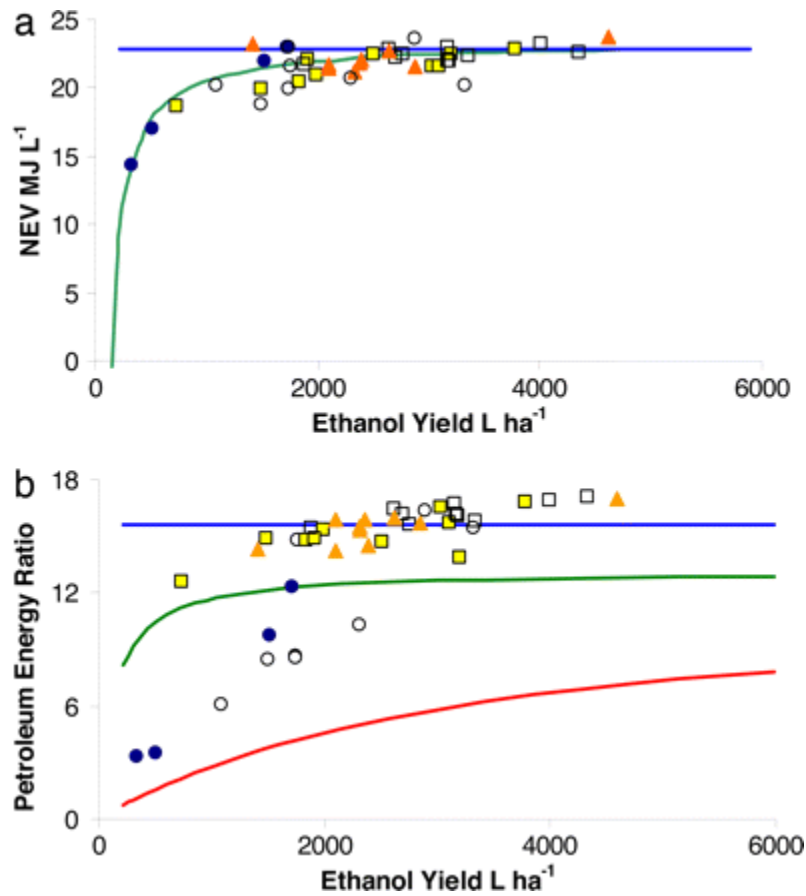

Fig. 23 - Energy estimates for 10 switchgrass fields managed for bioenergy for the establishment year (filled circle) and second (open circle), third (yellow square), fourth (open square), and fifth years (red triangle). (a) Comparison of net energy values ($\text{MJ}\cdot\text{liter}^{-1}$) from the fields based on known agricultural inputs with estimates from two simulated switchgrass studies. (b) PER, which is the biofuel output (MJ) divided by the petroleum (MJ) requirements for the agricultural, biorefinery, and distribution phases, for the 10 fields compared with three simulated studies.

Blue line, Wang; green line, Farrell *et al.* ; and red line, Pimental and Patzek.

Assuming the process goal is ultimately to produce gasoline for transportation fuel, there is one more process to consider. Turning ethanol into gasoline is a loss in efficiency over using ethanol or ethanol-rich gasoline blends but is necessary to produce an immediately usable product. Engines purpose-built for ethanol combustion would remove this requirement and allow the cellulose to ethanol process to be the sole determinant of efficiency. Adding a second conversion step creates additional energy and material requirements. The variety of both usable and unusable byproducts is also increased, as each step produces its own set of byproducts.

The costs of such a system are due to the use of a catalyst, conducting the process at a high temperature and pressure, and initial facility construction. Some of the energy requirements, as in the ethanol creation process, can be met using the high-energy byproducts. These products are usually light hydrocarbons that are not part of the gasoline and are a gas which can be siphoned off and burned for heat and electricity. A major factor in the efficiency of the process is using the heat produced by the exothermic conversion process for the distillation step³³.

Fig 24. - Efficiencies of various processes

Table IV. Comparison with Competing Processes^a

process	net process energy requirement, Btu/gal of ethanol	energy efficiency, %
solvent extraction	3600	95.9
distillation (to 60%) followed by reactions to gasoline (based on 1 gal of ethanol processed which produces 0.678 gal of gasoline)	1800	94.9–97.0 ^b
CO ₂ extraction	8000–11 000	90.4
vapor recompression (to 95%) followed by azeotropic distillation	15 800	84.3
conventional distillation (95%) followed by dehydration	19 200	81.5
conventional distillation (95%) followed by low temperature blending with gasoline	21 000	81.1
conventional two-stage distillation	27 400	75.5

The most efficient proposal for this ethanol to gasoline process achieved an overall energy balance of 0.95. Other methods range downward from this, but several reach at least 0.8 and can be considered viable. The most significant result of this value is that it is less than 1 and will therefore deduct from the efficiency of the overall cellulose to gasoline process. Additionally, these results did not take into account the energy requirement for the catalyst used or the construction of the facility used.

Combining the energy balance ratios of the switchgrass study and the most efficient ethanol to gasoline method, we have an overall energy balance of $5.4 * 0.95 = 5.13$. This is still a net energy gain but the margin of gain decreases when indirect costs for the process are considered. However, the study reporting these values was conducted in 1983 and used data from studies done previously and more efficient processes may be available, though any increase from a 95% energy balance in the ethanol to gasoline process would be marginal.

The overall process efficiency certainly makes gasoline from cellulose feasible, despite a variance in reported efficiency values. The major discrepancies are attributable to the question of system boundaries. In the production of the biomass the solar energy input is not always excluded and some studies consider the energy in the food of farmers as an input to the system, while many discount such values and ignore them in their calculations. Expenses such as fertilizer, lime, and land vary and the values used in the mentioned studies do not always agree. The biomass to ethanol process is subject to similar disagreements, such as the value of byproducts and whether the lignin is recovered to power the system. Gasoline production energy balance values are affected by the inclusion or neglect of the cost of catalysts or the value of gaseous or non-gasoline liquid products. Both chemical processes are subject to varying methods

of production and their associated efficiencies. Despite these complications in calculation, the consensus of studies holds that the production of gasoline from cellulosic feedstocks is an energy gain.

Application in Massachusetts

The results of the calculations section can now be interpreted on a practical level with regards to Massachusetts' fuel economy. It is important to note that the calculated values found previously are based off of several assumptions, so the results in this section will also be under those assumptions, and thus could potentially be inaccurate estimates.

The assumptions are as follows. First, upon investigation it was discovered that the “Grassoline” process is not yet in the experimental phase, meaning there is no real data on actual conversion rates between cellulose and gasoline with regards to this process. To get estimates, existing data relating to cellulosic ethanol production coupled with data from a process which yields gasoline from ethanol was used instead. With the Law of Conservation of Mass in mind, this assumption makes perfect sense. On the other hand, it must be noted that the “Grassoline” process would be more energy-efficient, as it is a single process rather than two processes together.

Second, it will be assumed in this section that the mass ratios of all plant matter are identical to Switchgrass. This may not be true, but it is likely that the deviations in cellulose content would not be great enough to introduce a significant amount of error in the results. It is worth noting that woody plants typically have greater cellulose concentration (hence their more rigid structure) and that if this was taken into account, the state of Massachusetts would likely be able to produce more cellulosic grassoline than what the final estimates will entail.

A third assumption will be the rates of public participation. An example of this would be what

percentage of owners of forested land would allow their land to be partially plowed and recultivated for a new generation of feedstock. The land owners would of course be compensated for their cooperation, but this would not guarantee their willingness to participate. Because the rates of participation could vary so greatly, each calculation involving this will be repeated several times so that a range of values can be observed rather than one single value which may or may not be realistic.

The state of Massachusetts is in great need of alternative fuels. It uses a great deal of gasoline for travel and infrastructure due to its dense population. It is heavily forested, so it could provide exorbitant amounts of woody feedstock. Its climate can support the growth of switchgrass, but its terrain is not ideal for switchgrass cultivation. Aside from its forests, Massachusetts has a variety of other sources of cellulose, most notably the wood waste attainable from its many lumberyards and furniture factories.

Feedstock cultivation in Massachusetts would be a challenge. The climate of Massachusetts is perfectly agreeable with poplars and even switchgrass, but there is not much open land for use. Most of Massachusetts is either towns or forests. It is also rather hilly, which makes mass cultivation a bit tougher to execute. Ultimately there are only a few practical options when it comes to growing feedstock within the state.

Some degree of deforestation would have to take place for the production of cellulosic gasoline in Massachusetts to be a practical investment. From this, several problems arise. First, much of Massachusetts' forest land is protected under the law due a multitude of state parks. Secondly, the people of Massachusetts tend to be rather concerned with the well-being of their environment, which makes the pursuit of privately-owned land for cultivation rather difficult. Even those people who would be willing to lend their land to feedstock would require payment, either for ownership of the land or periodically for partial use of the land. Lastly, there is the cost of infrastructure to consider. It would likely be hard to buy tracts of land in one area of the state if many land owners will be uncooperative. However, if this

problem was addressed by simply making deals with every willing land-owner the company could find, an exorbitant amount of money would be wasted on a fleet of trucks traveling all over the state, harvesting and transporting feedstock to one central location for processing.

It would be wise for the company in question to focus its attention on western Massachusetts. Cape Cod, Martha's Vineyard, and Nantucket are obviously not good choices, due to their lack of forestation and increased distance and difficulty of transit. Boston and the surrounding area is too urban to find any good spots for feedstock cultivation. Southeastern Massachusetts, meaning cities such as New Bedford and Dartmouth, is also fairly urban. Northeastern Massachusetts, including towns such as Methuen, would be a potential option. Western and central Massachusetts, however, is where the bulk of Massachusetts' forest land lies. A good location for the company's headquarters would be Worcester, as it is fairly equidistant between Boston and the western border of the state, while also serving as a hub of science and industry, which would of course aid the development of a biofuel company.

Approximately 3 million acres of land in Massachusetts is non-federal forest land. Let us assume that about 20% of the land is not within central or western Massachusetts, and that another 10% of the land is in use by lumber companies and thus its owners would have no interest in selling or leasing it. This leaves 2.16 million acres of forest land. Assuming a range of public cooperation from 20-50%, this means there will be 432,000 to 1,080,000 acres of land available. Of this land, probably only about 25-50% would be harvested, as it is likely that the land owners would want the majority of their land left alone for the sake of preservation or maintaining beautification around their homes. This means that only 108,000 to 540,000 acres would be available for clearance and cultivation.

Referencing the "Mass Balance" section, we see that 14,000 acres of land in the state are considered to be "idle" with approximately 180,000 acres divided between farm use and pasture. It is likely that the 14,000 acres of idle land are divided up throughout the state and thus should not be figured

into these calculations. However, the farm land could potentially be of some use. If 5-25% of this land was deemed excess by its owners, it could be sold or leased to the biofuel company. If so, an additional 9,000 to 54,000 acres could be gained. However, this land would not have the benefit of producing an immediate source of feedstock like the forested land would upon being clear-cut.

Overall, these figures add up to a potential of 117,000 to 594,000 acres of land able to cultivate switchgrass, of which 108,000 acres on the lower-bound estimate and 540,000 on the upper-bound estimate will produce a batch of feedstock upon start-up of operations. After three years the next batch would be ready. It is likely that some areas would be cut prematurely on purpose and reseeded to prevent vast periods of downtime for the company interested in this venture.

From the “Mass Balance” section, it is known that about 1675 liters of gasoline can be produced from a single acre every three years. Therefore, a grand total of 195,975,000 liters could be produced at each yield based on the lower-bound estimate, whereas 994,950,000 liters could be produced per yield if the upper-bound estimate was used.

Next the immediate gains from deforestation can be calculated. Since plant diversity is so great in forests, it is useless to try to estimate how much cellulose could be extracted from an acre of forest land. Instead another assumption can be made: each acre of forested land, due to the diversity of trees, shrubs, and grasses that have been growing in that spot for years, could give two times the yield of a mature acre of switchgrass. Since each acre of mature switchgrass yields 1675 liters, each acre of forest harvested will yield 3350 liters. Therefore, for the lower-bound estimate of 108,000 forested acres harvested, there could be an immediate gain of enough cellulose to produce 361,800,000 liters of gasoline. For the upper-bound estimate of 270,000 forested acres, there could be a gain of 904,500,000 liters.

So the results of the exploitation of unused forest-land and farmland would be as follows:

	Lower Estimate	Upper Estimate
Land Area	108,000 acres	540,000 acres
Immediate Yield	361,800,000 L or 2,277,000 barrels	1,809,000,000 L 11,382,000 barrels
Subsequent Yield (every 3 years)	195,975,000 L or 1,233,000 barrels	994,950,000 L 6,260,000 barrels

A Massachusetts Department of Conservation and Recreation study commissioned in 2002 surveyed wood and lumber production and wood waste produced throughout the state. The waste totals are separated into categories by the source and content. Municipal solid waste, construction and demolition debris, residue from primary wood manufacturers and secondary wood manufacturers, and urban wood residues.³⁴

Municipal solid waste recoverable wood waste consists mostly of wooden pallets and shipping containers.³⁵ The study further claims that in 1996, the year recorded in the study, only 39% of woody biomass was recovered and offered a potential maximum recovery of 75%. The total amount generated for that year was 523,500 tons, of which 204,165 tons were recovered. The cost and complexity of separating the wood waste from the waste stream are likely to be prohibitively high.

Fig. 25 – Wood residue tonnage

MSW WOODY RESIDUE	Generated (tons)	Recovered (tons)	Percent Recovered	Discarded (tons)
	523,500	204,165	39%	319,335

Construction and demolition waste includes a variety of materials, some of which are woody and recoverable. In 2004, 5,160,000 tons of construction and demolition waste were generated in Massachusetts, 660,000 of which were disposed of and 4,500,000 diverted for recycling or material-specific disposal. Of the diverted materials, 80,000 were wood. Of the 660,000 tons disposed and not diverted, 270,000 were disposed of in-state and 390,000 out of state.³⁶ Assuming 30% of this disposed material is woody³⁴ would provide approximately 200,000 tons of additional material, though as with the municipal solid waste the difficulty of separating the usable components would likely be prohibitive due to cost and complexity of sorting the incoming waste stream.

Primary manufacturers in this instance refer to sawmills in the state. A 2005 study of these Massachusetts sawmills reported 49 active facilities and 12 portable bandmills producing 49 million board feet of lumber, which is a reduction from the 94 active mills producing 100 million board feet in 1993.³⁶ Residue from these mills in 2000 totaled 290,768 tons.³⁴ These residues are commonly sent to out of state papermills and other markets.

Fig. 26 - Sawmill wood waste tonnage by type.

BARK (tons)	WOODCHIPS (tons)	SAWDUST (tons)	TOTAL (tons)
53,007	137,000	100,761	290,768

Secondary manufacturers include woodworking and furniture companies. Manufacturers in this category produce a wide varied of goods, including hardwood flooring, cabinets, mattress box springs, boats, brooms, and caskets. Massachusetts had 816 such firms in 2000 and they produced an approximate total of 225,000 tons of wood residue. This residue consists of sawdust, sander dust, wood chips, shavings, wood flour, rippings, cut-offs, and ends.³⁴

Urban wood residue is mostly comprised of wood from chips, logs, tops, brush, and whole

stumps, leaves collected seasonally, and grass clippings. Much of the urban wood residue is from tree trimming and removal and does not enter the waste management system as it is disposed of or given away immediately at the point it is generated. Approximately 56% of tree residues generated are managed on-site. The other 44% are landfilled (17%), sold (12%), sent to recyclers (3%), burned for energy (3%), and open burned, stockpiled, incinerated, or managed in other ways (9%).³⁷ In 1996 755,400 tons of woody residue were recovered from the 1,049,200 tons generated.³⁸

Fig. 27 – Urban wood residue tonnages

URBAN WOOD RESIDUE	Generated (tons)	Recovered (tons)	Percent Recovered	Discarded (tons)
	1,049,200	755,400	72%	293,800

The net tonnage for these waste streams is not clear from these figures, as recovery of all woody material is not feasible. If an attempt were made to sort the municipal solid waste, construction, and demolition streams, as well as to recover all woodchips and sawdust from the primary and secondary manufacturers and collect the urban wood residue, a net total of approximately 2,237,600 tons would be available. This figure uses the upper bounds of 75% municipal solid waste recovered, 30% of the construction and demolition waste, and 100% recovery of wood materials from primary and secondary manufacturers and 100% of urban wood residue collected. A more conservative estimate using only current recovery values for municipal, construction, and urban wood residues would give a total of about 1,555,300 tons of material recovered. However, this estimate includes 100% of the residues from primary and secondary manufacturers which may be unrealistic as these materials are currently sold as a product and acquiring them for fuel production would need to be cost-effective and not make

these materials completely unavailable to other industries. If we were to take 50% of the available residues in conjunction with the current recovery rates for municipal and construction waste and urban wood residue we arrive at a total of approximately 1,297,400 tons. These three values will be used to generate the low, medium, and high biomass availability estimates of total fuel production.

In the previous section we found a value of gasoline produced per ton of feedstock. This figure was for the use of the “grassoline” process using switchgrass as a feedstock. If we make the assumption that switchgrass and wood products have similar proportions of cellulose by weight we can use this value to find a rough estimate of gasoline produced per ton of wood waste. Using the 217 liters per ton we found previously and the three values of low, medium, and high biomass availability we find a total of 281,536,000 liters for low availability, 337,500,000 liters for medium availability, and 485,559,000 liters for high availability. This translates to 74,373,900 gallons, 89,158,000 gallons, and 128,271,000 gallons respectively. In terms of barrels of gasoline, this equates to 1,771,000 barrels, 2,123,000 barrels, and 3,054,000 barrels.

Fig. 28 - Approximate Gasoline Totals for Different Wood Waste Availability Scenarios

	Liters (per year)	Gallons (per year)	Barrels (per year)
Low	281536000	74373900	1771000
Medium	337500000	89158000	2123000
High	485559000	128271000	3054000

Using the estimates for forest clearance, switchgrass cultivation, and wood waste, we can now begin to compare the potential gasoline production to the amount of gasoline used up by Massachusetts' infrastructure each year. Because these three sources of feedstock are independent of each other timing-wise, it is necessary to determine the gasoline produced in terms of time:

Pessimistic Model

t=time in years m=(t/3) rounded down to the nearest whole number V=barrels produced

$$V=1,233,000m+1,771,000t+2,277,000$$

Optimistic Model

$$V=6,260,000m+2,123,000t+11,382,000$$

To get an idea of the range between these two models, a time-span should be inserted into the equations and thus the results could be compared. A sensible choice to investigate would be three years, the time it takes for a crop of switchgrass to mature. In addition we will test a decade.

t=3

Pessimistic Estimate: 8,823,000 barrels

Optimistic Estimate: 24,011,000 barrels

t=10

Pessimistic Estimate: 23,686,000 barrels

Optimistic Estimate: 51,392,000 barrels

With these estimates in mind, we should compare this to the data on Massachusetts fuel consumption to get an idea for how great an effect cellulosic gasoline could have in Massachusetts. In 2007, 70.6 million imported barrels of petroleum were used for motor gasoline in Massachusetts.¹⁵ This is not the total amount of petroleum imported, but because the travel sector uses the most petroleum and since it would be more convenient to focus on producing one type of fuel (although the “Grassoline” process can be used to produce any type of petroleum product), we will use this statistic for comparison. Assuming this rate of fuel importation has remained constant and will remain constant in the coming years, this means that in three years 211.2 million barrels will be imported and over ten years 706 million barrels will be imported.

Pessimistic Imported Fuel Displacement

$$t=3 \quad 8.823/211.2=4.18\%$$

$$t=10 \quad 23.686/706=3.35\%$$

Optimistic Imported Fuel Displacement

$$t=3 \quad 24.011/211.2=11.34\%$$

$$t=10 \quad 51.392/706=7.28\%$$

At first glance, these results could seem rather unimpressive. However, there is obviously plenty of money to be made by any company responsible for about 5% of the motor fuel economy of a population-dense state like Massachusetts. Not only that, but 5% of our fuel causing no net increase to the amount of CO₂ in the atmosphere is nothing to scoff at either.

The appeal of “Grassoline” is not that it can convert cellulose into gasoline—that can already be done through other processes. Rather, is that it can do this in a single step rather than two or more processes having to be used in conjunction. This saves energy, space, supplies, and ultimately money. Unfortunately, in this state it could prove difficult to keep either method of cellulosic gasoline production economically viable. Despite the fact that a company could make a lot of money with this technology, it would have to spend vast sums of money buying or leasing high-value land, cultivating and shipping feedstock all around the state, and purchasing every scrap of wood waste available. One potential solution would be state government incentives for biofuel corporations; perhaps if land was offered by the state at low prices, some prospective companies could get their start without too much trouble. However, it seems like

this technology would simply work better in a less developed area with flatter terrain and cheaper land values, where vast tracts of land could be bought cheaply so that a company could cultivate its crop in one central location rather than in many scattered locations miles away.

Based on our investigation into the viability of cellulosic gasoline as a product, it would seem that it is indeed a potentially lucrative and environmentally-friendly alternative fuel source, but that for the state of Massachusetts, such a technology could be somewhat impractical. We conclude that it may be profitable for a private fuel company to produce fuel in this way, but since the potential biomass in Massachusetts is dwarfed by the demand that using this as a major source of gasoline would produce, we do not believe it can be adopted on a large enough scale to significantly offset imported gasoline.

We would recommend creating a test plot of several acres and growing a suitable biomass specifically for biofuel production for 5-10 years to fully understand costs, environmental impact, crop viability, and potential yield.

Sources

- (1) Ruggeri, Amanda. (3/9/09). *What the Stimulus Package Does for Renewable Energy*.

Retrieved December 2, 2009, from U.S. & World Report News' website:

<http://www.usnews.com/articles/news/energy/2009/03/06/what-the-stimulus-package-does-for-renewable-energy.html>

- (2) Pearson, Chris. (8/13/07). *Understanding the Cost of Solar Energy*.

Retrieved December 2, 2009, from Green Econometrics' website:

http://greenecon.net/understanding-the-cost-of-solar-energy/energy_economics.html

- (3) Energy Kinetics, Inc. (2008). *Environmental and Economic Fuel Comparison*.

Retrieved December 2, 2009, from Energy Kinetics' website:

<http://www.energykinetics.com/savingsHeatingFuelComparisons.shtml>

- (4) Chambers, Nick. (1/9/09). *First Cellulosic Ethanol Plant in USA Up and Running*.

Retrieved December 2, 2009, from Green Options Media's website:

<http://gas2.org/2009/01/09/first-cellulosic-ethanol-plant-in-usa-up-and-running/>

- (5) Country Journal Publishing Co. (2009). *Building Cellulose*.

Retrieved December 2, 2009, from Country Journal Publishing's PDF:

<http://www.grainnet.com/pdf/cellulosemap.pdf>

- (6) Renewable Fuels Association. (2009). *Ethanol Facts: Engine Performance*.

Retrieved December 11, 2009, from RFA's website:

<http://www.ethanolrfa.org/resource/facts/engine/>

- (7) U.S. Department of Energy. (2009). *Properties of Fuels*.

Retrieved December 11, 2009, from the United States Department of Energy's PDF:

<http://www.afdc.energy.gov/afdc/pdfs/fueltable.pdf>

- (8) Huber, George W., & Dale, Bruce E. (July 2009). Grassoline at the Pump.

Scientific American, 52-59.

- (9) Bransby, David. *Switchgrass Profile*.

Retrieved December 15, 2009, from Oak Ridge National Library's website:

<http://bioenergy.ornl.gov/papers/misc/switchgrass-profile.html>

- (10) Meadowbrook Nursery. (2008). *Northwind Switch Grass*.

Retrieved December 15, 2009, from Meadowbrook Nursery's website:

<http://www.we-du.com/detail.php?plant=PREPANNW>

- (11) Land, Graham. (October 17, 2009). *Switchgrass—America's own biofuel. But is it any good?*

Retrieved December 15, 2009, from:

<http://www.greenfudge.org/2009/10/17/switchgrass-%E2%80%93-america-%E2%80%99s-own-biofuel-but-is-it-any-good/>

- (12) Scurlock, J.M.O. (March 16, 1999). *Miscanthus: A Review of European Experience with a Novel Energy Crop*.

Retrieved December 15, 2009, from Oak Ridge National Library's website:

<http://bioenergy.ornl.gov/reports/miscanthus/toc.html>

(13)Fast Growing Trees Nursery. (2009). *Hybrid Poplar Trees*.

Retrieved December 15, 2009, from Fast Growing Trees Nursery's website:

<http://www.fast-growing-trees.com/HybridPoplar.htm>

(14)Fast Growing Trees Nursery. (2009). *Weeping Willow Shade Trees*.

Retrieved December 15, 2009, from Fast Growing Trees Nursery's website:

<http://www.fast-growing-trees.com/WeepingWillow.htm>

(15) Energy Information Administration, State/Territory Energy Profiles. (April 29,2010).

Retrieved December 16, 2009, from EIA website:

http://tonto.eia.doe.gov/state/state_energy_profiles.cfm?sid=MA

(16) United States Department of Agriculture, Major Uses of Land. (2002).

Retrieved December 16, 2009, from USDA's PDF:

<http://www.ers.usda.gov/Data/MajorLandUses/MLUsummarytables.pdf>

(17) National Biomass Map. (2008).

Retrieved December 20, 2009 from:

http://news.cnet.com/i/ne/p/2008/Biomass-Map_550x425.jpg

(18)Projects & Programs – Energy & Environment. (2008). *Where is the Money Going? Citizen Update on Energy and the Environment*.

Retrieved December 20, 2009 from the Commonwealth of Massachusetts' website:

http://www.mass.gov/?pageID=stimterminal&L=4&L0=Home&L1=Spending+and+Reports&L2=Where+is+the+mone y+going%3f&L3=Citizens%27+Update&sid=Fstim&b=terminalcontent&f=citizen_update_energy_environment&csid=Fstim

(19) MA Sustainable Forest Bioenergy Initiative. (2009).

Retrieved from Commonwealth of Massachusetts' website:

http://www.mass.gov/?pageID=eoeeaternal&L=4&L0=Home&L1=Energy%2c+Utilities+%26+Clean+Technologies&L2=Renewable+Energy&L3=Biomass&sid=Eoeea&b=terminalcont&f=doer_renewables_biomass_bioenergy_initiative&csid=Eoeea

- (20) Woody Biomass Energy – MA Sustainable Forest Bioenergy Initiative (June 2008). Retrieved January 23, 2010 from Commonwealth of Massachusetts' website: <http://www.mass.gov/Eoeea/docs/doer/renewables/biomass/woody-biomass-energy.pdf>
- (21) National Renewable Energy Laboratory – From Biomass to Biofuels (August 2006). Retrieved December 20, 2009 from NREL's PDF: <http://www.nrel.gov/biomass/pdfs/39436.pdf>
- (22) Qteros-Biofuels from Advanced Microbiology. (2010). Retrieved November 22, 2009 from Qteros' website: www.Qteros.com
- (23) Biomass and Bioenergy. (2009). *Bio-Oil and Bio-Char Production From Corn Cob and Corn Stover by Fast Pyrolysis*
- (24) Conversion of Biomass to Oil. Retrieved December 20, 2009 from Princeton University's website: http://blogs.princeton.edu/chm333/f2006/biomass/bio_oil/02_chemistryprocessing_the_basics/02_processing/
- (25) Laser, M. Jin, H. Dale, B. Jayawardhana, K. Lynd, L. “Projected mature technology scenarios for conversion of cellulosic biomass to ethanol with coproduction thermochemical fuels, power, and/or animal feed protein.” (2009). *Biofuels, Bioproducts, and Biorefiners*, vol. 3, p. 231-246
- (26) Whitcraft, D. Verykios, X. Mutharasan, R. Recovery of Ethanol from Fermentation Broths by Catalytic Conversion to Gasoline. (1983) American Chemical Society, p. 452-457
- (27) Iogen Corporation. (2009). Retrieved February 5, 2010 from Iogen's website: http://www.ioген.ca/cellulosic_ethanol/what_is_ethanol/index.html
- (28) ZSM-5 made from siliceous ash. (2009). Retrieved February 5, 2010 from online patent: <http://www.freepatentsonline.com/6368571.html>
- (29) Ethanol Net Energy Balance. (2001). Retrieved February 7 from EERE's website: http://www1.eere.energy.gov/biomass/net_energy_balance.html

- (30) Farrel, A. Plevin, R. Turner, B. Jones, A. O'Hare, M. Kammen, D. Ethanol Can Contribute to Energy and Environmental Goals. (January 27, 2009). Retrieved February 20, 2010 from University of California, Berkeley's PDF:
<http://rael.berkeley.edu/sites/default/files/EBAMM/FarrellEthanolScience012706.pdf>
- (31) <http://www.newrules.org/sites/newrules.org/files/images/netenergyresponse.pdf>
- (32) Schmer, M. Vogel, K. Mitchell, R. Perrin, R. Net energy of cellulosic ethanol from switchgrass. (November 21, 2007) Retrieved February 20, 2010 from PNAS' website:
<http://www.pnas.org/content/105/2/464.full>
- (33) Aldridge, G. Verykios, X. Mutharasan, R. Recovery of Ethanol from Fermentation Broths by Catalytic Conversion to Gasoline. (1984) American Chemical Society, p. 733-737
- (34) The Woody Biomass Supply in Massachusetts: A Literature-Based Estimate. (May 2002). Retrieved April 25, 2010 from Commonwealth of Massachusetts' PDF:
http://www.mass.gov/dcr/stewardship/forestry/utilmark/supply_report.pdf
- (35) Strategic Plan to Promote the Use of Recyclable Materials in Massachusetts Project. (November 1998). Retrieved April 25, 2010 from Chelsea Center's PDF:
<http://www.chelseacenter.org/pdfs/Phase%20II.PDF>
- (36) Massachusetts Directory of Sawmills and Dry Kins—2006. (2006). Retrieved April 25, 2010 from Commonwealth of Massachusetts' website:
<http://www.mass.gov/dcr/stewardship/forestry/utilmark/SawmillDirectory2006.pdf>
- (37) Chelsea Center for Recycling and Economic Development. (April 2000). *Technical Report #19*. Retrieved April 25, 2010 from Chelsea Center's PDF:
<http://www.chelseacenter.org/pdfs/TechReport19.pdf>

- (38) Strategic Plan to Promote the Use of Recyclable Materials in Massachusetts Project. (March 1999). Retrieved April 25, 2010 from Chelsea Center's PDF: <http://www.chelseacenter.org/pdfs/Phase%20III-Mar99.PDF>