

**DETECTING THE ROLE OF OXR1 IN SPONTANEOUS  
MUTAGENESIS**

A Major Qualifying Project Report

Submitted to the Faculty of the

WORCESTER POLYTECHNIC INSTITUTE

in partial fulfillment of the requirements for the

Degree of Bachelor of Science

in

Biology and Biotechnology

by

---

Sean Durrigan

April 24, 2008

APPROVED:

---

Michael R. Volkert, Ph.D.  
Molecular Genetics and Microbiology  
UMass Medical Center  
Major Advisor

---

David S. Adams, Ph.D.  
Biology and Biotechnology  
WPI Project Advisor

## **ABSTRACT**

Aerobic respiration produces reactive oxygen species (ROS) which can cause DNA lesions, which lead to mutation. This project's goal is to detect DNA damage due to the presence/absence of the protein Oxr1, which regulates ROS levels in cells. This is done by growing yeast strains that contain combinations of wild type and mutant Oxr1 and Ogg1 alleles. Ogg1 is a repair protein which repairs lesions caused by ROS. These cultures are plated on arginine deficient minimal media and the same media with canavanine to measure mutation frequency. Colonies are counted and mutation frequency is calculated for each strain to determine which genotypes have higher mutation frequencies and are thus less efficient at reducing spontaneous mutagenesis. Results indicated that Oxr1 plays a small role in spontaneous mutagenesis.

# TABLE OF CONTENTS

Signature Page .....	1
Abstract .....	2
Table of Contents .....	3
Acknowledgements .....	4
Background .....	5
Project Purpose .....	14
Methods .....	15
Results .....	20
Discussion .....	26
Bibliography .....	29

## **ACKNOWLEDGEMENTS**

I would like to take this opportunity to thank everyone that played a part in helping me with the completion of this project. First I would like to thank Dr. Volkert for allowing me to work in his lab, and whose tireless patience with me and my questions helped me learn everything I know about this project and its subject material. I would also like to thank Anita Fenton and Lijian Yu, who were always willing and able to answer any procedural or technical questions I had while in the lab. I would like to thank Dr. Poteete and Dr. Murphy, who luckily worked similar late night hours in the lab as I did, and were always willing to assist me after everyone else had gone home. I should also thank Jagamaya who was able to help on several procedures. Finally I would like to thank Dr. Adams for initiating this project with Dr. Volkert and his lab, and for his help in the completion of this paper.

## BACKGROUND

### Reactive Oxygen Species

Reactive oxygen species, also called ROS, are molecular products of aerobic respiration which can be harmful to cells if their levels are not regulated within the body (Volkert et al, 2000). These molecules can be created endogenously, such as through metabolic pathways, or exogenously, through environmental conditions (Mroczek and Kufel, 2008). Reactive oxygen species include hydrogen peroxide, hydroxyl radicals, and superoxides (Lenaz, 1998).

There are a variety of exogenous sources of ROS. Exogenous sources of oxygen can be coupled with metals such as iron to form hydroxyl radicals using the Haber-Weiss reactions. Hydrogen peroxide itself has very little reactivity and does not pose a major threat to cells, however hydroxyl radicals ( $\cdot\text{OH}$ ) have a high level of reactivity and high levels can cause oxidative stress (Cohn, et al., 2006), the effects of which are discussed later. Thus it is important that peroxide levels, as well as hydroxyl radical and superoxide levels, are kept in check. Figure 1 displays the series of chemical reactions catalyzed by Fe (II) and oxygen molecules. The first two equations are Haber-Weiss reactions, resulting in the formation of hydrogen peroxide. The third equation is the Fenton reaction, which results in the formation of hydroxyl radicals (Cohn et al, 2006).

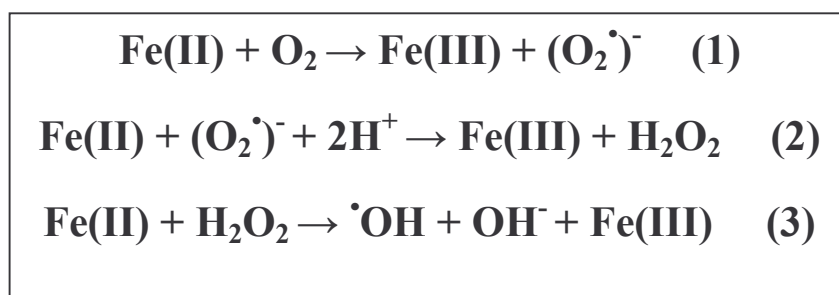

Figure 1: Formation of hydroxyl radicals (Cohn, et al., 2006).

Exposure to UV, cytokines, growth factors, environmental toxins, and ionizing radiation are but a few of the other exogenous sources of ROS (Salmon, et al., 2004).

Aerobic respiration or energy production can also produce hydrogen peroxide, superoxide, and hydroxyl radicals (Fenton and Volkert, 2008). The mitochondrion is host to several aerobic metabolic processes involved in the electron transport system and is the major source of reactive oxygen species from within the cell (Elliot and Volkert, 2004). Hydrogen peroxide and hydroxyl radicals can be produced in mitochondria through the reactions shown in figure 1. Single electrons from the mitochondrial respiratory chain can reduce  $O_2$  to a superoxide anion (DeJong, et al., 2007).

As mentioned before, buildup of ROS can be very harmful to cells. Reactive oxygen species, at high levels, can chemically alter lipids, proteins, and DNA. In the case of DNA, ROS reacts with nucleotide bases to form lesions such as 5-hydroxyuracil and 5-hydroxymethyluracil (Kulkarni and Wilson, 2008). However, the most common lesion is 8-oxoguanine, which is mutagenic because it frequently mispairs with adenine during replication leading to a GC→TA transversion (Pope, 2006).

ROS has been linked to the process of ageing, and as an organism gets older, the amount of oxidative damage increases as the ability of cells to control ROS levels declines (Kregel and Zhang, 2007). This is supported by the fact that GC →TA transversions accumulate during aging and degenerative diseases (Mandavilli, et al., 2002). In addition, mutations in genes coding for ROS regulation can cause a decrease in ROS level regulation and an increase in oxidative damage. If not properly regulated, reactive oxygen species can cause diseases such as, Friedreich's ataxia, Parkinson's

disease, Huntington's disease, cancer, and Alzheimer's disease (Thorpe, et al., 2004; Maccarrone and Ullrich, 2004).

Reactive oxygen species are also involved in apoptosis and cell senescence, though the exact mechanisms and pathways are not yet known. Cell senescence is the aging of cells due to deterioration of certain structures and functions (Chen, et al., 2007).

Figure 2 displays contributions to ageing from DNA damage. ROS result in DNA damage, which leads to senescence or apoptosis, both of which contribute to ageing.

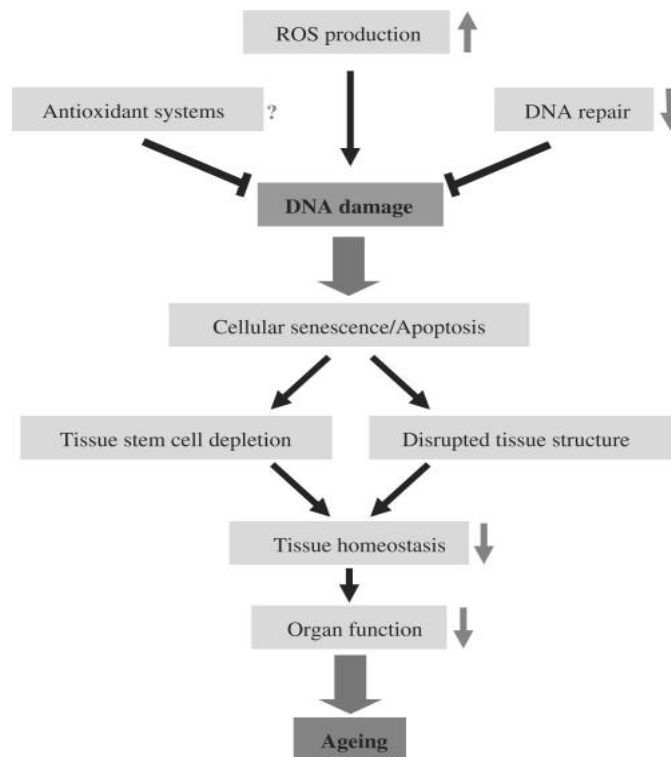

Figure 2: Accumulation of DNA Damage that leads to Ageing (Chen, et al., 2007).

### ROS Prevention and Repair

Aerobic respiration is a vital process in all eukaryotes, and thus reactive oxygen species are inevitable in all eukaryotic cells. However, cells have antioxidants to regulate

the constantly changing ROS levels within cells to prevent damage. There are also repair proteins that can repair the damage that ROS inflicts .

The first defense against reactive oxygen species is detoxification by antioxidants such as super oxide dismutase (SOD), peroxidase and catalase. These sets of enzymes are parts of an antioxidant pathway that culminates in the conversion of ROS' to harmless compounds H<sub>2</sub>O and O<sub>2</sub>. SOD is able to break down ROS into hydrogen peroxide and oxygen; catalase is able to break down hydrogen peroxide into water and oxygen (Yu, et al., 2006), and peroxidases, which are also able to break down hydrogen peroxide into water, as well as detoxifying organic peroxides (Mandavilli et al, 2002). There are several different forms of SOD (including the more common SOD1, SOD2), but the Cu, Zn SOD1 makes up 90% of superoxide dismutase activity in the cell and is located primarily in the cytoplasm (Imlay, 2003).

As mentioned before, the mitochondrion is the single biggest source of ROS in a eukaryotic cell, and ROS levels will be at their highest there. Therefore, mtDNA is at a bigger risk to oxidative damage and mutation than nuclear DNA. To combat this risk, mitochondria contain many repair enzymes that function to reverse the damaging effects oxidative stress has on DNA. One way to reverse this damage is through excision repair; which exists in three different forms. The first is base excision repair (BER); the second is mismatch repair (MMR); and the third is nucleotide excision repair (NER). These three pathways are common in that they remove the damaged base, form a single strand break gap at the site of the damaged base, and use polymerases and ligases to restore the correct base into the DNA (Kulkarni and Wilson, 2008).



In the first step of BER, a DNA glycosylase removes the damaged/mutated base by cleaving its glycosylic bond, which leaves a sugar without a base called an abasic site, also known as an apurinic/aprimidinic (AP) site (Gembka et al, 2007). One such glycosylase is OGG1. The abasic site is then cut on the 5' end by APE (AP endonuclease), forming a 3'-OH and 5'-deoxyribose phosphate (dRP). Some glycosylases, such as OGG1, contain an AP lyase that cuts at the 3' end of the gap rather than the 5', leaving a 3' dRP group that is also repaired by APE (Horton and Wilson, 2007). BER then proceeds to either short-patch or long-patch repair. In short-patch repair, the gap is filled by DNA polymerase  $\beta$  with the correct base, while the dRP lyase activity of Pol $\beta$  removes the 5' dRP. This forms a nicked strand that can then be ligated by a XRCC1/LigIII $\alpha$  complex to complete repair (Hashimoto et al., 2004). If the 5' terminus is not a substrate for polymerase  $\beta$ , then long-patch repair occurs. It is here that polymerase  $\delta$  or  $\epsilon$  adds a string of nucleotides through strand replacement, while the dRPase activity of pol  $\beta$  removes the 5' dRP group. The damaged strand is then clipped by flap endonuclease FEN1 and the nicked strand is ligated by LigI (Sobol et al, 2000; Kulkarni and Wilson, 2008). This process is summarized in Figure 3.

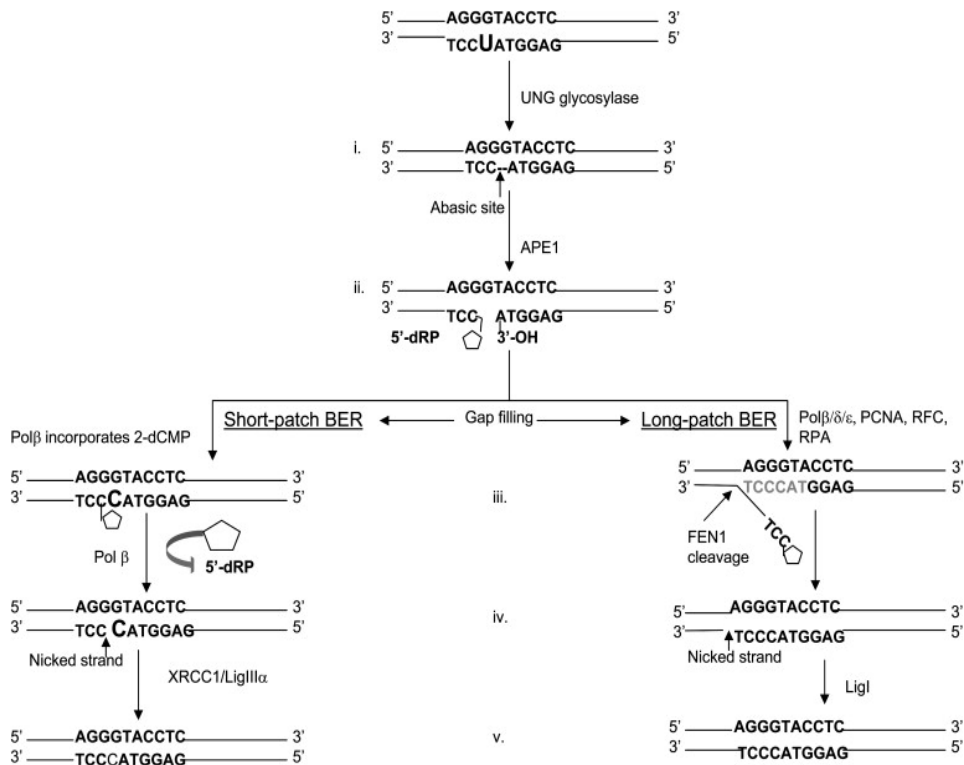

**Figure 3: Summary of Base Excision Repair (Kulkarni and Wilson, 2008).**

In mismatch repair, enzymes such as MutS $\alpha$  (comprised of MSH2-MSH6 heterodimer) and MutS $\beta$  (a MSH2-MSH3 heterodimer) recognize mismatches within the DNA. MutS $\alpha$  recognizes single base pair mismatches, and 1-2 base pair mismatches that arise from mismatches that result from insertions, while MutS $\beta$  recognizes 2-10 base pair mismatches from insertions or deletions (Kulkarni and Wilson, 2008). These enzymes then recruit an enzyme called MutL, which makes a cut near the mismatched base in the newly synthesized strand (Song et al., 2006).

Nucleotide excision repair is necessary to repair certain oxidative changes to DNA bases. There are two separate pathways, global genome repair (GGR) and transcription coupled repair (TCR). GGR repairs lesions in the genome while TCR fixes

damage in DNA that prevents RNA polymerase from being able to elongate DNA during transcription (Kulkarni and Wilson, 2008).

## **OXR1**

Eukaryotic cells have another defense against ROS in the form of OXR1 proteins. Unlike OGG1 and MSH2, very little is known about OXR1. It was discovered during a screen for oxidation protection genes by transforming *E. coli* DNA oxidation repair defective strains with a human cDNA library and screening for a decrease in mutation activity (Volkert et al, 2000). This same study also showed that the OXR1 gene is an important factor in protecting eukaryotes from oxidative damage (Volkert et al, 2000). Figure 4 shows one of the results of this study. Two different strains of yeast, one wild type and one OXR1 mutant, were treated with hydrogen peroxide and plated on YEPD media. Results clearly showed that a mutation to OXR1 lowered the chances for survival in cells when in the presence of an oxidizing agent, such as hydrogen peroxide.

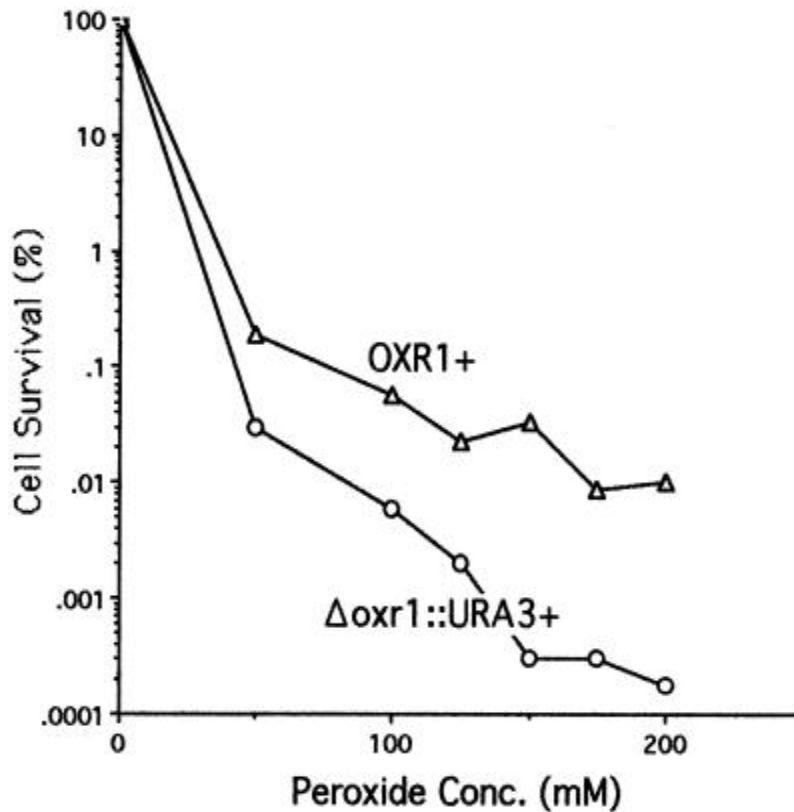

**Figure 4: Comparison of resistance between wild type and *oxr1Δ::URA3* strains of yeast to increasing hydrogen peroxide treatment (Volkert et al, 2000).**

Later studies showed that OXR1 can be induced and localizes within the mitochondria when there is a rise in ROS levels within cells and is part of a stress response pathway that is turned on during ROS production (Elliot and Volkert, 2004). It was also determined that OXR1 is involved in the defense against both endogenously and exogenously produced ROS. Sodium azide, an inhibitor of electron transport Complex IV, cytochrome C oxidase, causes ROS produced by Complex III to leak into the cell. OXR1 mutants are sensitive to azide treatments (Fenton and Volkert, 2008). Similarly, hydrogen peroxide treatments also increase ROS levels in OXR1 mutants and thus lowers cell survival rate (Elliot and Volkert, 2004; Fenton and Volkert, 2008).

## **Spontaneous Mutagenesis**

Spontaneous mutation is any mutation to DNA caused by intracellular events. Spontaneous mutation has played a role in evolution, and also been cited as a cause for genetic disease, cancer, and ageing (Kunz et al, 1998). Spontaneous mutagenesis measures the frequency at which these mutations occur.

In this particular study, spontaneous mutation was used to analyze the frequency of mutations on the CAN1 locus. In order to do so, cultures are grown on two separate plates, one minimal media that is deficient in arginine, and one that is identical, but also contains canavanine. Canavanine is an analog of arginine, which are both taken into the cell by the same permease, encoded by the can1 locus. Yeast cells are sensitive to the drug canavanine, and any cell that imports it into the cell is unable to grow. Mutations in the Can1 gene, however, prevents canavanine intake, and these canavanine resistant mutants are able to grow. Arginine is not included in the media because canavanine is a competitive inhibitor (Adams et al, 1997).

The mutation frequency is calculated by dividing the number of mutants per mL by the total number of cells per mL. In order to determine the number of mutants per mL and total cells per mL, the number of colonies are counted on the canavanine and arginine plates respectively, and then multiplied by the dilution that was plated. The experiment is run several times to obtain an average mutation frequency for each strain, and then compared to the averages of other strains (Michael Volkert, personal communication).

## **PROJECT PURPOSE**

In this study, I used or constructed several different combinations of yeast strains containing wild type and/or mutant *ogg1* and *oxr1* genes in two different genetic backgrounds. This was done to study the role that Oxr1 plays in spontaneous mutagenesis. Data from this study indicates that the presence of Oxr1 is able to lower spontaneous mutation frequency in one genetic background compared to with an isogenic Oxr1+ strain. However, in another genetic background that lacked the *Ogg1* gene, which repairs a major oxidative DNA lesion, we expected a synergistic increase in mutations due to the inability to repair oxidative damage due to the deletion of *Ogg1* and the higher level of production of ROS due to the deletion of *Oxr1*. The expected synergistic increase was not seen and possible explanations are discussed.

## METHODS

### Yeast Strains

Table 1 shows a list of the yeast strains used in this study and their parental strains.

**Table 1: Yeast Strains Used In This Study.**

Strain	Genotype	Parent Strain
MVY500	ogg1Δ::hisG-URA3-hisG msh2 Δ::KanMX4	MVY101
MVY502	ogg1Δ::hisG msh2Δ::KanMX4	MVY101
MVY251	ogg1Δ::hisG	MVY101
MVY502-1	ogg1Δ::hisG msh2Δ::KanMX4 oxr1Δ::URA3 <sup>+</sup>	MVY101
N1-9	oxr1Δ::URA3 <sup>+</sup>	R117
251-2	ogg1Δ oxr1Δ::URA3 <sup>+</sup>	MVY101
251-3	ogg1Δ oxr1Δ::URA3 <sup>+</sup>	MVY101
N1-4	OXR1 <sup>+</sup> ura3 <sup>-</sup>	R117
MVY101	OXR1 <sup>+</sup> OGG1 <sup>+</sup>	MVY101

### Creation of MVY502 Strain

Cultures of strain MVY500 were grown overnight in 5 ml YPD at 29°C and 100 μl was plated on 5-fluoro-uracil acid medium (FOA). This medium was used to select for colonies that had deleted the URA3 sequence through homologous recombination between the two flanking hisG repeats. Strains lacking URA3 are able to grow on FOA media. Colonies that grew were picked and streaked on more FOA plates in order to purify these colonies. Purified colonies were grown overnight in 5 ml YPD at 29°C.

### Confirmation of MVY502 Strain

In order to confirm that FOA resistant colonies had deleted their URA3 sequence, two separate experiments were run. First, MVY502, as well as MVY500, DNA was purified. A 1.5 ml aliquot of an overnight culture grown in YPD was pelleted by centrifuging for 5 minutes at 10,000 rpm. The cell pellet was resuspended in 300 μl lysis

solution (Epicentre Biotechnologies), and incubated at 65°C for 15 minutes. After 15 minutes, the samples were placed on ice for 5 minutes, and then 150 µl of Protein Precipitant Reagent (Epicentre Biotechnologies) was added. The sample was vortexed for 10 seconds, then spun in a centrifuge for 10 minutes at 10,000 rpm. The supernatant was transferred to a new tube, and 500 µl isopropanol was added. Samples were spun for 10 minutes at 10,000 rpm, and washed with 500 µl 70% ethanol, then air dried. The total genomic DNA pellet was then resuspended and stored in TE (10 mM Tris-HCl, pH 8.0, 1 mM EDTA). This DNA was then used as the template in a PCR reaction using URA3 primers 312 and 313. The purpose of these primers was to copy the OGG1 locus sequence of interest, as well as some flanking sequences to prove that the URA3 portion of the *ogg1Δ::hisG-URA3-hisG* sequence was successfully deleted. Table 2 summarizes the protocol for cloning the URA3 Locus DNA with PCR. PCR samples were then electrophoresed on a 1% agarose in TAE (tris acetate buffer) gel to view the sizes of each amplicon band to ensure that they were of correct size.

**Table 2: PCR Protocol for Amplifying the URA3 Locus From MVY500 and MVY502 Purified DNA.**

	Pre-heat	Denature	Anneal	Elongation	Cycle	Final Elong.
Step	1	2	3	4	5	6
Temp (°C)	94	94	55	72	Go to 2	72
Time (min)	5	1	1	5	29x	10

To confirm the correct sequence of DNA and confirm the gel electrophoresis experiment, strain MVY502 was grown on Ura<sup>-</sup> and Ura<sup>+</sup> plates. 100 µl of overnight culture was plated on each. If the strain deleted the URA3 sequences, no colonies would grow on the Ura<sup>-</sup> plate, while there would be growth on the Ura<sup>+</sup> plate. This is because strains that were FOA resistant should lack the URA3 sequence and would need uracil in order to grow.



## **Transformation Preparation**

Before transformation, MVY502 and MVY251 cultures were grown overnight in 5 ml YPD at 29°C. After 24 hours of incubation, concentrations of 100 ul, 10 ul, 1 ul and 0.1 ul of these cultures were added to 5 ml YPD and again allowed to grow overnight at 29°C; the cultures closest to the desired OD<sub>600</sub> of 1.6 ( $2 \times 10^7$ ) after overnight incubation were made competent for transformation.

The N1-9 genomic DNA for use as a template for amplification of the *oxr1*Δ::*URA3* fragment was prepared by precipitating the DNA with ethanol. Fifty ul of N1-9 (*oxr1*Δ::*URA3*<sup>+</sup>) PCR product was mixed with 5 ul 3M Na-Acetate pH 5.0, and 140 ul 100% ethanol. The mixture was centrifuged for 20 minutes at 18,000 g, and the supernatant removed. The pellet was washed twice with 70% ethanol, and centrifuged again, but for 2 minutes. The supernatant was removed and the pellets were dried in a speed vacuum for 10 minutes. The N1-9 DNA was then resuspended in 100 ul 10% TE.

## **Transformation of N1-9 DNA into MVY502 and MVY251**

Each concentration of MVY502 and MVY251 (100, 10, 1, 0.1 ul) was diluted in 1ml of sterile water and OD<sub>600</sub> was read. The culture for each strain closest to an absorbance of 1.6 ( $2 \times 10^7$  cells /ml) was used in the transformation. The cells were made competent by centrifuging at 5,000 rpm for 5 minutes, resuspending in water, centrifuging again for 5 minutes at 5,000 rpm, and resuspended in 100 mM LiAc. Cells were then pelleted and the 100 mM LiAc was removed. Next, 240 ul of PEG (50%), 36 ul of 1M LiAc, 25 ul of carrier DNA (2 mg/ml), and 50 ul of DNA in TE (0.1-10 ug) was added. A high efficiency yeast transformation was performed, inserting the N1-9

(*oxr1Δ::URA3<sup>+</sup>*) DNA fragment into the genomes of the MVY502 and MVY251 strains by transformation and homologous recombination.

### **Transformant Selection**

In order to select for MVY502 and MVY251 strains that had successfully been transformed with the N1-9 DNA, 100 ul of transformants resuspended in sterile water were plated on Uracil deficient media. Cells that received the *oxr1Δ::URA3<sup>+</sup>* DNA also integrated URA3 into their genome and are able to grow on uracil deficient media, while cells that did not receive the DNA lacked URA 3 and are unable to grow. To ensure accuracy, colonies that were able to grow on Ura- plates were picked and streaked on fresh Ura- plates to isolate and purify them, as well as to confirm their ability to grow without the presence of uracil in the medium

### **Storage of Transformed Strains**

Confirmed transformed strains were grown overnight in 5 ml YPD at 29°C. After incubation, 1.5 ml of culture was mixed with 1.5 ml 30% glycerol and placed in a -80°C freezer for long-term storage. These transformants were labeled 502-1, 251-2, and 251-3.

### **Spontaneous Mutagenesis**

Cultures of strains MVY251, N1-9, N1-4, 502-1, 251-2, 251-3, and MVY101 were grown overnight in 5 ml YPD at 29°C. A 10<sup>-5</sup> serial dilution was made for each culture, and 100 ul of the 10<sup>-5</sup> dilution was plated on YPD media. These cultures were allowed to grow for one week at 29°C. After one week, individual colonies were picked

and placed in 100 ul of sterile water. This mixture was then diluted 1:100 and OD<sub>600</sub> was read. Each dilution was adjusted to achieve an absorbance of 26 (3 x 10<sup>6</sup> cells / ml). Next, 100 ul at a dilution of 10<sup>0</sup> of these adjusted cultures were plated on minimal media containing canavanine and deficient in arginine. A 10<sup>-5</sup> serial dilution was made for each of the adjusted concentrations, and 100 ul was plated on identical minimal media deficient in arginine but also deficient in canavanine. Plates were incubated at 29°C for one week. The number of colonies on the arginine / canavanine deficient plates were counted and multiplied by 10<sup>7</sup> to obtain the total number of cells / ml. The number of colonies that grew on the media containing canavanine were also counted, multiplied by the dilution factor of 10, which gave the total number of mutants / ml. The number of mutants / ml was divided by the total number of cells / ml, which resulted in the mutation frequency for that strain. This process was repeated several times for each strain and the average mutation frequency for each strain was determined.

## RESULTS

### Creation of New Yeast Strains for Use in Mutagenesis

In order to calculate the spontaneous mutation frequency in *ogg1Δ/oxr1Δ* double mutants, new strains would need to be constructed. First, in order to create a strain that could be used as a host in transformation experiments, yeast strain 500 was plated on FOA-plates in order to select for colonies that had undergone random recombination between homologous *hisG* gene sequences, thus removing *URA3* from its genome. This new strain, labeled MVY502, shown in table 1, could then be used for transformation experiments. This process of homologous recombination is summarized in figure 5.

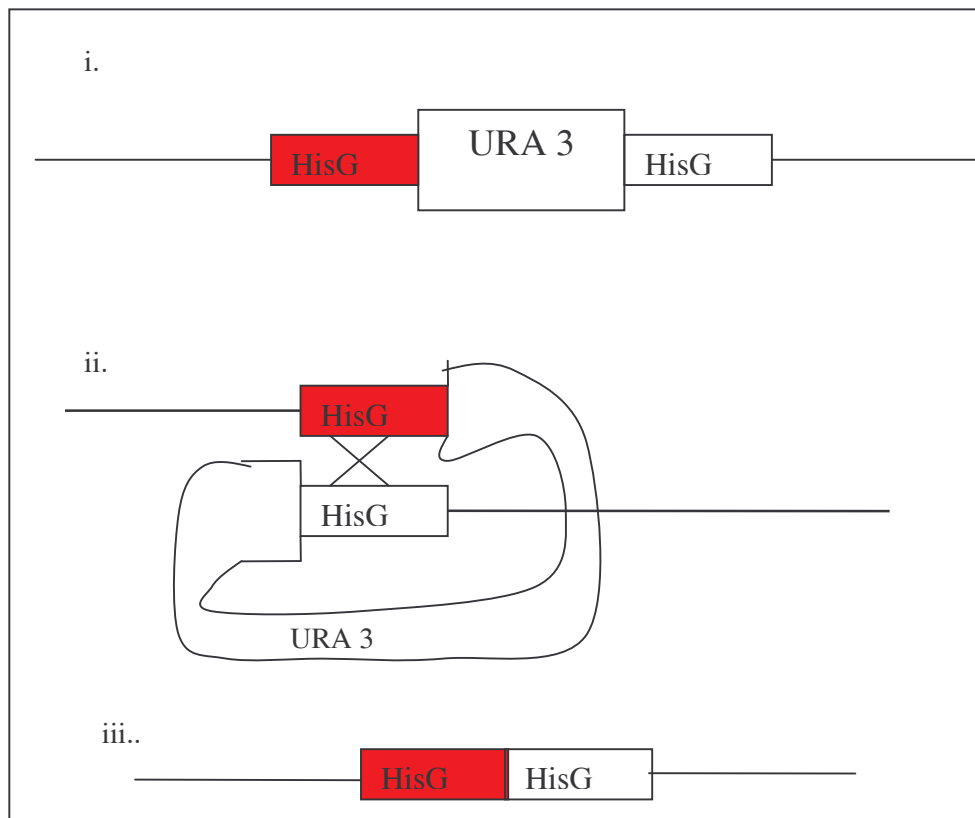

**Figure 5: Random Recombination of Yeast Strain MVY500:** i) Diagram i shows a part of the MVY500 DNA sequence *hisG:URA3:hisG*. ii) Diagram ii portrays homologous sequences (*hisG*) lining up and a possible recombination (x) that would remove *URA3* from the sequence. Recombinant proteins are involved in the lining up of homologous sequences (not pictured). iii) Diagram iii shows the new sequence (MVY502) that would allow yeast to grow on FOA plates.

The second set of strains that was constructed was transformants. A purified DNA fragment containing *oxr1Δ::URA3<sup>+</sup>* from strain N1-9, which was amplified using the PCR protocol discussed above, was transformed into strains MVY502 and MVY 251 using a high efficiency yeast transformation. The genotypes of all four constructed strains are shown in table 3.

**Table 3: Genotype of Constructed Strains MVY502, MVY502-1, 251-2, and 251-3.**

Strain	Genotype
MVY502	<i>ogg1Δ::hisG msh2Δ::KanMX4</i>
MVY502-1	<i>ogg1Δ::hisG msh2Δ::KanMX4 oxr1Δ::URA3<sup>+</sup></i>
251-2	<i>ogg1Δ oxr1Δ::URA3<sup>+</sup></i>
251-3	<i>ogg1Δ oxr1Δ::URA3<sup>+</sup></i>

### **Oxr1 Has a Role in Preventing Spontaneous Mutagenesis in Yeast**

Previous studies have shown that Oxr1 has an important role in oxidative protection in yeast (Volkert et al, 2000). To test if this includes prevention of mutation caused by oxidation, spontaneous mutagenesis experiments were run with strains N1-9, and N1-4, *oxr1* mutant and wild type, respectively. The average mutation frequencies for these two strains are listed in table 4. Figure 6 compares the mutation frequency of the two strains. The results confirmed that Oxr1 plays a role in prevention of spontaneous mutagenesis in yeast, as a *oxr1* mutation resulted in about 3.7 x more mutations than the wild type ( $p = 0.016$ ).

**Table 4: Average Mutation Frequency for N1-4 and N1-9.**

Strain	Average Mutation frequency
N1-4	$3.100 \times 10^{-6}$
N1-9	$1.142 \times 10^{-5}$

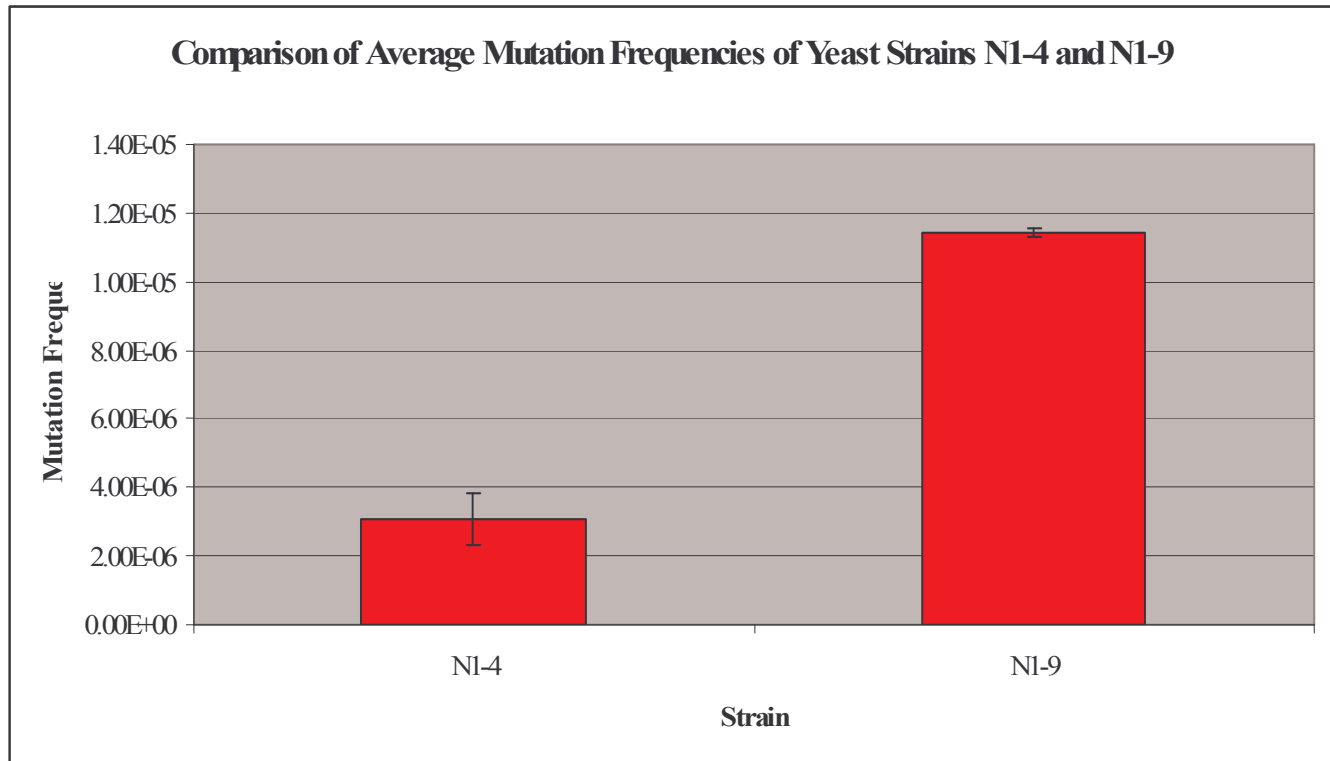

**Figure 6: Average Mutation Frequencies for Strains N1-4 and N1-9.** Standard deviation bars are shown above each strain's histogram. The data is significantly different as the p-value is less than 0.05 (p=0.016).

### **Ogg1 is Important in Preventing Spontaneous Mutagenesis in Yeast**

In order to measure if *oxr1Δ* increased mutagenesis in an *ogg1Δ* strain, spontaneous mutagenesis was measured in an *ogg1Δ* single mutant (MVY251). Mutagenesis was also measured in a wild type strain (MVY101) for comparison. The average mutation frequency for these two strains is shown in table 5, and a visual comparison is portrayed in figure 7. Results show that a mutation to Ogg1 results in an increase of about 6.3 x mutations when compared to a wild type strain. The standard deviation for MVY101 is high due to the fact that one mutation frequency calculation was at  $\sim 1.31 \times 10^{-5}$ .

**Table 5: Average Mutation Frequency for Strains MVY251 and MVY101.**

Strain	Average Mutation Frequency
MVY101	$4.888 \times 10^{-6}$
MVY251	$3.090 \times 10^{-5}$

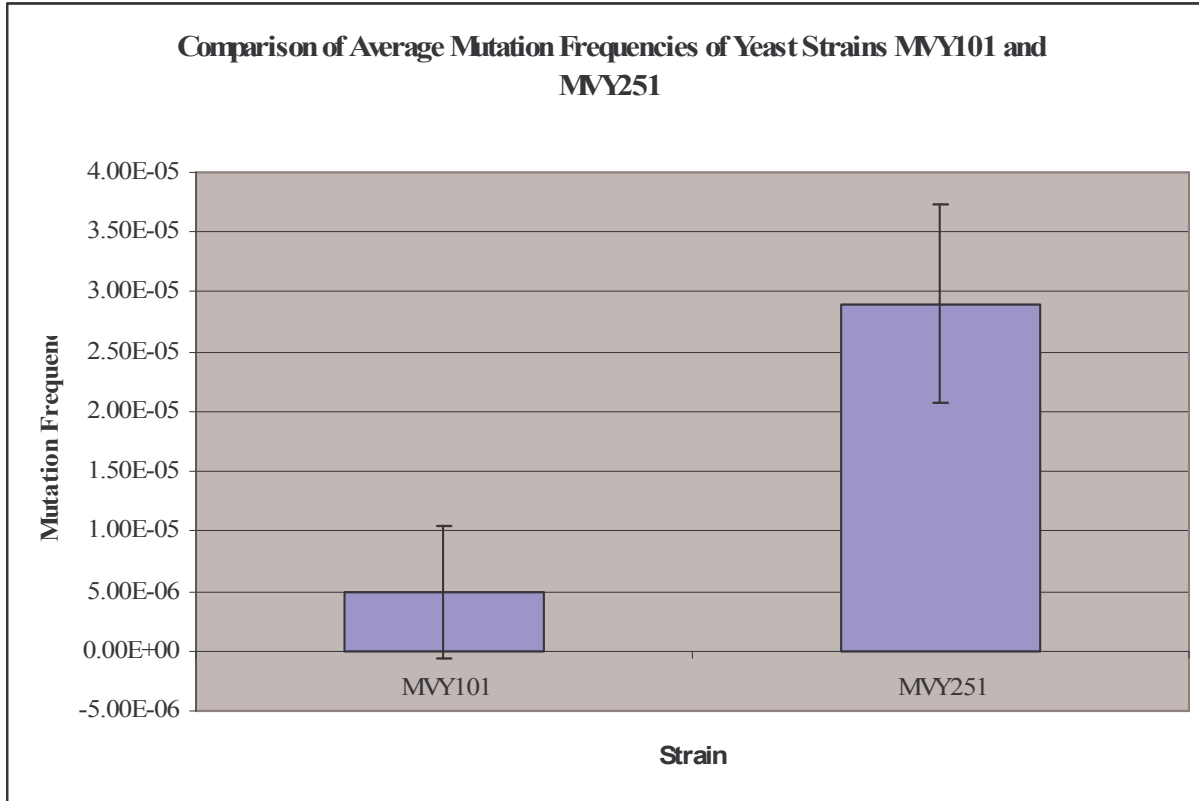

**Figure 7: Average mutation frequencies for strains MVY101 and MVY251.** Standard deviation bars are shown above each strain's histogram. p-value could not be calculated as sample sizes were n=5 and n=3 for MVY101 and MVY251, respectively.

### **oxr1Δ Does Not Increase Mutagenesis in ogg1Δ Single Mutant Strains**

One of the goals of this study was to measure if *oxr1Δ* would increase mutagenesis in a strain that already contained a mutated *Ogg1* gene. Spontaneous mutagenesis in two *oxr1Δ ogg1Δ* double mutant strains, 251-2 and 251-3, was done and these frequencies were compared to the mutation frequencies of strains MVY251 (*ogg1Δ Oxr1+*) and MVY101 (*Ogg1+ Oxr1+*). Table 6 displays the average mutation frequency for each strain. Figure 8 portrays a comparison of the two transformed double mutant

strains (251-2, 251-3) with the wild type strain (MVY101) and *ogg1* single mutant strain (MVY251). The comparison of MVY101 and the double mutants indicates that collectively, *oxr1* $\Delta$  *ogg1* $\Delta$  increase spontaneous mutations in yeast by a factor of about 6-fold and 7 fold for 251-2 and 251-3 respectively. Also, comparison of the double mutants with the *ogg1* single mutant shows that there is no noticeable difference in mutation frequencies, implying that *oxr1* $\Delta$  does not increase mutagenesis in an *ogg1* $\Delta$  mutant strain.

**Table 6: Average Mutation Frequency for Yeast Strains MVY101, MVY251, 251-2, and 251-3.**

Strain	Average Mutation frequency
MVY101	$4.888 \times 10^{-6}$
MVY251	$3.090 \times 10^{-5}$
251-2	$2.805 \times 10^{-5}$
251-3	$3.22 \times 10^{-5}$

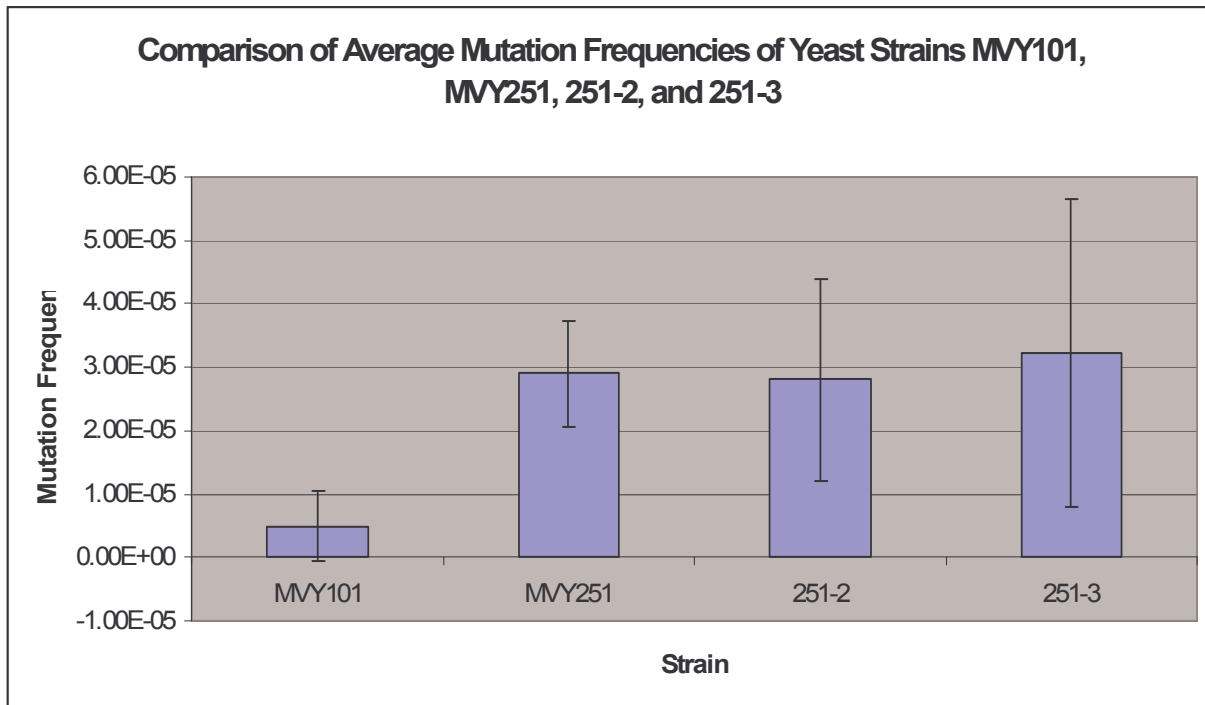

**Figure 8: Comparison of Mutation Frequencies in Wild Type MVY101, MVY251, and Transformants 251-2 and 251-3.** Standard deviation bars are shown above each strain's histogram. There is no significant difference in the data for strains 251-2 and 251-3, as the p-value is above 0.05 (p=0.311). There is a significant difference in the data between both 251-2 and 251-3 compared to MVY101 as both p-values are lower than 0.05 (p= 0.0024 for 251-2 and p= 0.0025 for 251-3).



Figure 9 displays a comparison of the average mutation frequencies for each strain. The purpose of this is to compare mutagenesis for strains with different background. Strains N1-4 and N1-9 had different genetic backgrounds than the other strains, as shown in table 1 above, and these strains had a lower overall mutagenesis frequency.

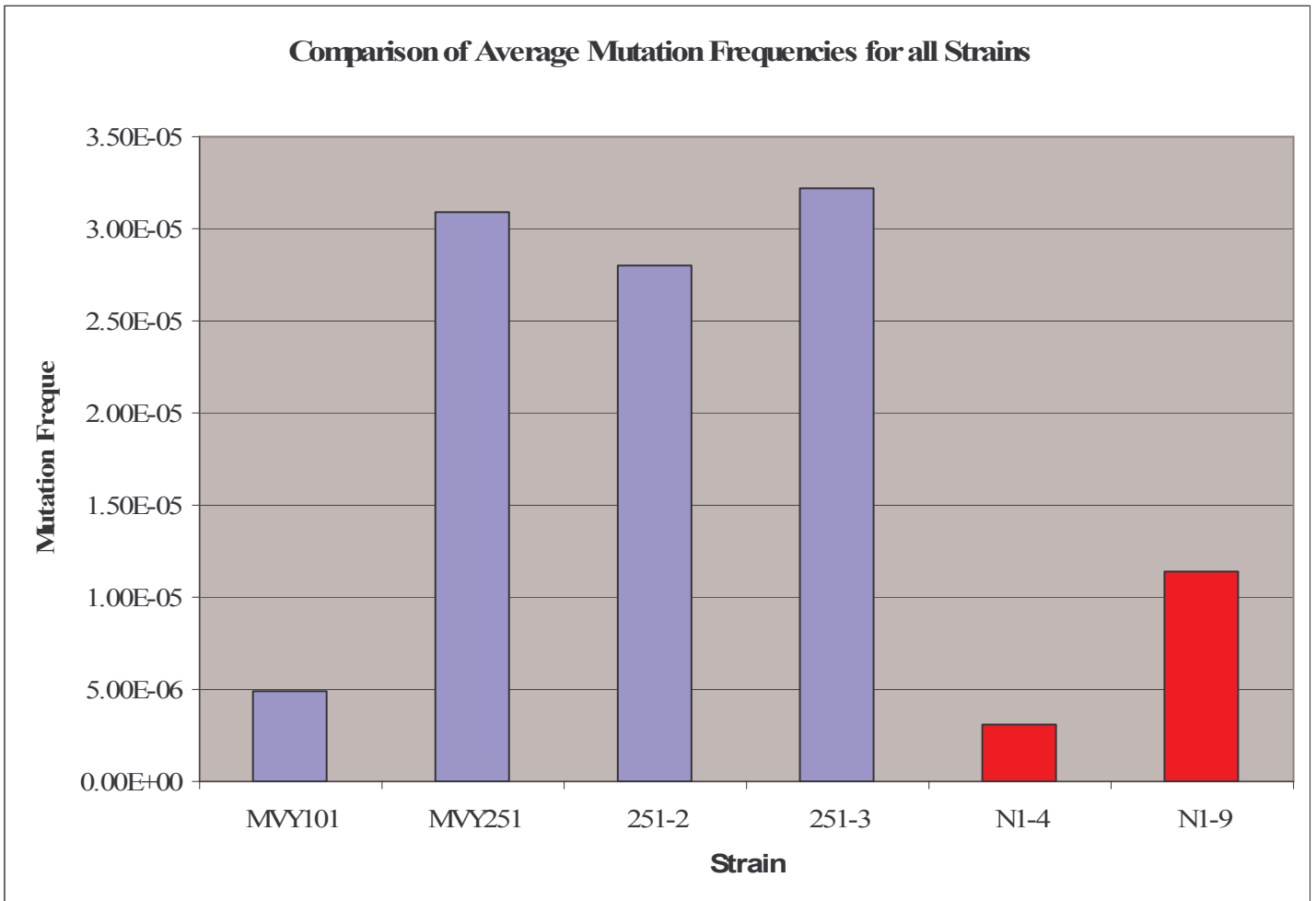

**Figure 9: Comparison of Mutation Frequencies for All Strains.**

## DISCUSSION

The goal of this project was to determine the role *oxr1* plays in spontaneous mutagenesis. Previous studies had shown that *oxr1* mutants were sensitive to exogenous sources of ROS, such as hydrogen peroxide (Elliot and Volkert, 2004). Thus it was believed that *oxr1* mutations would increase mutation frequency in yeast because of Oxr1's role in reducing oxidative stress. Comparison of mutation frequency in wild type and mutant Oxr1 strains (N1-4 and N1-9 respectively) supports this data, shown in table 4 and figure 6, as a loss of function of Oxr1 results in a higher frequency of mutagenesis. This indicates that, along with its other functions, Oxr1 also plays a role in reducing spontaneous mutagenesis.

Ogg1 is a protein that repairs a particular lesion in DNA, 8-oxo-guanine, preventing oxidative mutagenesis (Horton and Wilson, 2007). The results shown in table 5 and figure 7 support this theory, as a mutation to Ogg1 (MVY251) increases spontaneous mutagenesis considerably over the wild type strain (MVY101). Assuming that this rise in mutagenesis is the consequence of an increase in oxidative mutagenesis, then it can be predicted that a combination of decreased repair due to a mutated Ogg1 and decreased spontaneous mutagenesis prevention due to a mutated Oxr1 would result in a synergetic increase in spontaneous mutagenesis for the double mutant strains (251-2, 251-3), if the elevated spontaneous mutagenesis in the *oxr1* mutant strain is due to increased oxidative damage. However, the results shown in table 6 and figure 8 refute this prediction; there is no significant difference between the *ogg1* single mutant and the *ogg1 oxr1* double mutant strains.

There are several possibilities that could cause this conflict in data. It should first be noted that the N1-9 and N1-4 strains come from a different parent strain (R117) than do the other strains used in this study (MVY101), as shown in table 1. Previous studies have shown that superoxide dismutase (SOD) levels actually increase to compensate for the loss of Oxr1 (Fenton and Volkert, unpublished results). The MVY101 background may more efficiently express this gene that compensates for the loss of Oxr1 than the R117 background. It is also possible that other compensatory genes are more efficiently expressed in MVY101 derived strains than those derived from R117 that reduce the effect of *oxr1* in the MVY101 genetic background.

Another possibility is that the mutagenesis in *oxr1*Δ strains is not due to 8-oxo-guanine lesions, and the high frequency of mutation in *ogg1*Δ strains is covering the low level increase due to *oxr1*Δ. As shown in figure 9, the mutation frequency in the *oxr1*Δ strain (N1-9) is considerably lower than the frequency in the *ogg1*Δ strain (MVY251).

There are several experiments that could be performed in order to continue this study and either confirm one of the possible explanations discussed above, or refute some of the results discussed in the previous section. To test the first explanation, that the MVY101 derived strains are more efficient in compensating for the loss of Oxr1, SOD and ROS levels could be measured in all strains used in this study. It has been shown that the *oxr1* mutant strain N1-9 has higher ROS levels than its wild type parent N1-4 (Fenton and Volkert, unpublished results). It is also possible that MVY101 derived strains have a higher level of SOD than R117 strains, thereby counteracting the elevated ROS levels due to the *oxr1* mutation. Another possible experiment is to induce oxidative mutagenesis by treating N1-4 and N1-9 strains with hydrogen peroxide. Mutagenesis

would increase for both strains, but the increase in the *oxr1*Δ strain (N1-4) would be more than in the wild type strain (N1-9). This could also be done to the other strains, to compare the role that Ogg1 and Oxr1 play in countering the effects of exogenous and endogenous sources of ROS. It is also possible to use other repair genes, coupling *oxr1*Δ with mutations to genes such as *msh2*, and looking for synergy. If the mutations resulting in the *oxr1*Δ strain are not due to 8-oxo-guanine lesions, then there should be synergy between Oxr1 and other repair enzymes that do not repair this particular lesion.

## BIBLIOGRAPHY

Adams A et al (1997), *Methods in Yeast Genetics*. New York: Cold Spring Harbor Laboratory Press.

Chen JH., Hales CN, Ozanne SE (2007), DNA damage, cellular senescence and organismal ageing: causal or correlative? *Nucleic Acids Res.* **35(22)**: 7417-7428.

Cohn CA et al (2006), Role of pyrite in formation of hydroxyl radicals in coal: possible implications for human health. *Part Fibre Toxicol.* **3**: 16.

DeJong RJ et al (2007), Reactive oxygen species detoxification by catalase is a major determinant of fecundity in the mosquito *Anopheles gambiae*. *Proc Natl Acad Sci USA.* **104(7)**: 2121-2126.

Elliot, N.A., Volkert, M. R., (2004) Stress induction and mitochondrial localization of Oxr1 proteins in yeast and humans. *Mol Cell Biol.* **24(8)**: 3180-3187.

Fenton A, Volkert MR (2008), The OXR1 gene product reduces reactive oxygen species (ROS) in yeast. Unpublished.

Gembka A et al (2007), The checkpoint clamp, Rad9-Rad1-Hus1 complex, preferentially stimulates the activity of apurinic/aprimidinic endonuclease 1 and DNA polymerase  $\beta$  in long patch base excision repair. *Nucleic Acids Res.* **35(8)**: 2596-2608.

Hashimoto K et al (2004), Futile short-patch DNA base excision repair of adenine:8-oxoguanine mispair. *Nucleic Acids Res.* **32(19)**: 5928-5934.

Horton JK, Wilson SH (2007), Hypersensitivity phenotypes associated with genetic and synthetic inhibitor-induced base excision repair deficiency. *DNA Repair (Amst).* **6(4)**: 530-543.

Imlay J (2003), Pathways to oxidative damage. *Annual Review of Microbiology.* **57**: 395-418.

Kregel KC, Zhang HJ (2007), An integrated view of oxidative stress in aging: basic mechanisms, functional effects, and pathological considerations. *Am J Physiol Regul Integr Comp Physiol.* **292(1)**: R18-R36.

Kunz BA et al (1998), DNA sequence analysis of spontaneous mutagenesis in *Saccharomyces cerevisiae*. *Genetics.* **148**: 1491-1505.

Kulkarni A and Wilson DM (2008), The involvement of DNA-damage and repair defects in neurological dysfunction. *Am J Hum Genet.* **82(3)**: 539-566.

Lenaz G (1998), Role of mitochondria in oxidative stress and ageing. *BBA*. **1366(1-2)**: 53-67.

Maccarrone M, Ullrich V (2004), Redox regulation in disease and ageing. Published online for Nature Publishing Group. **11(8)**: 949-951.

Mandavilli BS et al (2002), Mitochondrial DNA repair and aging. *Mutat Res*. **509(1-2)**: 127-151.

Mroczek S, Kufel J (2008). Apoptotic signals induce specific degradation of ribosomal RNA in yeast. *Nucleic Acids Res*. (published online before print).

Pope P (2006), The role of sub1 in the repair of UV induced DNA damage in *Saccharomyces cerevisiae*. Major Qualifying Project, Worcester Polytechnic Institute.

Salmon TB et al (2004), Biological consequences of oxidative stress-induced DNA damage in *Saccharomyces cerevisiae*. *Nucleic Acids Res*. **32(12)**: 3712-3723.

Sobol RW et al (2000), The lyase activity of the DNA repair protein beta-polymerase protects from DNA-damage-induced cytotoxicity. *Nature*. **405(6788)**: 807-810.

Song H et al (2006), Common variants in mismatch repair genes and risk of invasive ovarian cancer. *Carcinogenesis*. **27(11)**: 2235-2242.

Thorpe GW et al (2004) Cells have distinct mechanisms to maintain protection against different reactive oxygen species: Oxidative-stress-response genes. *Proc Natl Acad Sci*. **101(17)**: 6564-6569.

Volkert M, Elliot NA, Housman DE (2000), Functional genomics reveals a family of eukaryotic oxidation protection genes. *Proc Natl Acad Sci*. **97(26)**: 14530-14535.

Yu L et al (2006), Autophagic programmed cell death by selective catalase degradation. *Proc Natl Acad Sci USA*. **103(13)**: 4952-4957.