

ALTERNATIVE SNOWBOARD RIDING

A Major Qualifying Project Report:

Submitted to the Faculty

of the

WORCESTER POLYTECHNIC INSTITUTE

in partial fulfillment of the requirements for the

Degree of Bachelor of Science

by

---

William Feraco

---

Trevor Hajko

---

David Trujillo

Date: March 26, 2014

Approved:

---

Professor J. Sullivan, Major Advisor

## Abstract

Snowboarding is a relatively new sport that is still in its early stages of development. To date, the major advances in this sport are the use of lighter, cheaper, more durable materials paired with more aerodynamic designs. The goal of this project was to design, fabricate and test a system that would provide snowboarders with an alternative riding experience. Our prototype consisted of a binding to board interface consisting of top plate, bottom plate, and a roller bearing, that when put together, attached to any 4-by-4 or 4-by-2 style board and allowed the rider to freely rotate their feet between a pre-determined degree of freedom. The team designed the top and bottom plates in SolidWorks, and used the computer aided manufacturing system Esprit along with a three axis CNC machine, to create the top and bottom plates out of Nylon 6-6.

Once the design was fully assembled the group performed bending and torsional strain tests to determine if the snowboard's dynamics were compromised due to the addition of the apparatus. A tensile test was also performed on the connection between the threaded inserts and Nylon plates to determine the maximum applied force they could withstand before becoming dislodged from their original position in the top plate. Our results demonstrated that they could withstand the forces presented in riding conditions. The final test performed was held at Mount Wachusett Ski Area to determine the safety and functionality of the design. At Mount Wachusett, the system was put under real world conditions, giving the team a better understand of the riding experience that it provided. The design was thoroughly reviewed by the Wachusett Ski Patrol team for safety and applicability. Their endorsements were incredibly favorable. All of the tests performed were successful and informative. The group was able to determine minor design modifications that will benefit the overall success of the product. The apparatus was functional. It potentially reduced risk of injury to the rider. The overall riding experience was noticeably

different from conventional snowboarding. The ability to rotate ones feet provided an innovative means of controlling the snowboard that could create a successful alternative riding experience.

The team is currently in the process of obtaining a patent for this design.

## Acknowledgements

At the culmination of this project we, as a group, would like to take the time to thank all of those who helped us make this project a success. More specifically we would like to thank our advisor Professor John Sullivan for taking time to meet with us every week and help us resolve an issues that arose. He provided guidance at an unprecedented level. This project would not have been able to happen if it wasn't for his input in our designs and general advice.

We would also like to thank Professor Satya Shivkumar for taking the time to allow us to use his Instron machine and help us run our tensile testing. His knowledge and willingness to work with us made the test possible.

Additionally we would like to thank Peter Hefti. As the Experimentation Lab manager, he permitted us to utilize any equipment we needed to perform our strain gauge test. His donation of ten strain gauges took additional cost off of our budget and allowed us to proceed with testing in a timely manner. His explanation of how to use the amplifier was crucial in the success of the test.

Jeff Crowley, President of Wachusett Mountain in Princeton Massachusetts permitted us to use his mountain and ski patrol lodge as a location to test our apparatus in real world conditions. He graciously donated free lift passes to the group so as we could stay under budget. Additionally, Mike Halloran of Wachusett Mountain Ski patrol paired us up with members of ski patrol. Their input was extremely valuable pertaining to testing methods.

We would like to thank Professor Christopher Brown for donating his testing foot apparatus to our project. This foot allowed the group to perform a strain gauge test in a manner which emulated forces similar to that of a human test subject.

Lastly, we would like to thank Emmit Joyal, our Washburn Lab Assistant. He guided us through the entire machining process. His knowledge of three axis machining made the entire process efficient and successful.

## Table of Contents

Abstract .....	1
Acknowledgements .....	3
Table of Figures .....	7
Introduction .....	8
Background .....	9
History of Snowboarding .....	9
Snowboarding Today .....	11
Components .....	12
The Snowboard .....	12
Bindings .....	13
Rotational Bindings .....	16
Methodology .....	17
Introduction .....	17
Research .....	17
Patent Reviews and Analysis .....	19
Preliminary Testing .....	21
Prototype 1 .....	21
Prototype 2 .....	23
Design .....	24
Design Constraints .....	24
Design Features .....	25
Machining .....	33
Assembly .....	36
Strain Test .....	38
Materials and Methods .....	38
Results and Conclusion .....	43
Tensile Test .....	45
Materials and Methods .....	45
Results and Conclusions .....	47
Mountain Test .....	48
Materials and Methods .....	48
Results and Conclusions .....	50
Future Design Features .....	56

Conclusions.....	59
References.....	60
Appendices.....	62
Appendix A: Machining Process of Bottom Plate.....	62
Appendix B: Machining Process of Top Plate.....	64
Appendix C: Tensile Test Results.....	66
Appendix D: Frame-by-Frame view of Toe to Heel Side Turn.....	68
Appendix E: CAD Drawings .....	75

## Table of Figures

Figure 1: History of Snowboarding Timeline .....	11
Figure 2: Snowboard Binding Mounting Patterns .....	13
Figure 3: Types of Snowboard Bindings .....	15
Figure 4: Breakdown of Problem Statement.....	18
Figure 5: Bottom Plate of Rotational Snowboard Assembly.....	20
Figure 6: Exploded Drawing of US Patent 6,450,511 B1.....	21
Figure 7: Barstool Swivel Bearings .....	22
Figure 8: Prototype 1 .....	23
Figure 9: Prototype 2 .....	24
Figure 10: Prototype 2 Binding Connection .....	24
Figure 11: Thrust Needle Bearing/Washer Assembly .....	26
Figure 12: Plate Axis'.....	27
Figure 13: Structural Star Design .....	28
Figure 14: Center Bolt .....	31
Figure 15: Washburn Band Saw .....	34
Figure 16: Collet Fixture Assembly.....	35
Figure 17: Machined Top (Right) and Bottom (Left) Plates .....	36
Figure 18: Press Fit of Threaded Inserts .....	37
Figure 19: Strain Gauge Location.....	39
Figure 20: Aluminum Plate.....	39
Figure 21: Boot/Foot Apparatus .....	40
Figure 22: Testing Foot.....	40
Figure 23: Bending Strain with Conventional Attachment.....	41
Figure 24: Torsional Strain with Conventional Attachment.....	41
Figure 25: Bending Strain with Rotating Apparatus.....	42
Figure 26: Torsional Strain with Rotating Apparatus.....	42
Figure 27: Chart of Bending and Torsional Strain Data .....	43
Figure 28: Chart of Deflection to Calculate Bending Stresses .....	44
Figure 29: Scrap Nylon used for Tensile Testing (left) and Thumb Screw (right).....	46
Figure 30: Tensile Test Setup .....	47
Figure 31: Standing in Chair Lift Line with Rotational Apparatus .....	51
Figure 32: Group Member Getting on Chair Lift with Rotational Apparatus .....	51
Figure 33: Riding on Chair Lift with Rotational Apparatus .....	52
Figure 34: Gap between Plates .....	55
Figure 35: Snow Accumulation in Bearing Encasement .....	56
Figure 36: Potential Top Plate Design #2 .....	58
Figure 37: Machining Process Breakdown of Bottom Plate in ESPRIT .....	63
Figure 38: Machining Process Breakdown of Top Plate in ESPRIT .....	65



## Introduction

The sport of snowboarding has not always been as popular as a sport as it is today.

Snowboarding started off as a very rough idea, essentially a piece of wood attached to one's feet to navigate down a snow covered mountain. During the early 1960's, snowboarding was seen as an abomination to its brother sport, skiing. Many Ski areas refused to allow snowboarders into their resorts. Slowly, more and more individuals became interested in snowboarding due to its growing popularity and high adrenaline nature. Improvements such as upgraded materials, metal edges and bindings made snowboarding a more appealing sport. The question then becomes, where will these improvements stop?

Most recently, bindings have been constructed to allow easy access into and out of the binding. This reduces wasted time once departed from the lift and allows for a more enjoyable, stress free riding experience. One issue that has arisen with snowboarding is maneuvering on flat ground while still strapped into the front binding. Certain bindings have been constructed to rotate in such a way that allows the rider to position their front foot so as to ride the snowboard as a skateboarder would ride a skateboard, using the back foot to propel forward. While this partial rotation is helpful for flatland, there are no bindings that allow free rotation of the feet while riding. In this project, we will create an alternative riding experience by designing and manufacturing a snowboard binding that allows the rider to freely rotate his/her feet while in operation.

## Background

### History of Snowboarding

Snowboarding is a rather recently developed sport, becoming popular in the 1960's. It is difficult to associate a name with the title of "Inventor of Snowboarding" due to the many attempts. In 1929, M.J. "Jack" Burchett created the first snowboard by attaching his feet to a cut out sheet of plywood with clotheslines and horse reins (Pelletier). While primitive, this design was in part, the basis for what is known today as the snowboard.

It was not until 1965 that the development of the sport of snowboarding was expanded upon. Sherman Poppen designed the first snowboard that could be purchased in stores. He called it a Snurfer, since snowboarding is similar to surfing and skiing. It was a combination of a wooden sled and a skateboard. Poppen added a rope to the front of two skis that were tied together, to allow for some control and included steel tacks the stick through the top of the wood that provided a gripping point to hold the rider's feet. It became a huge hit and over half a million Snurfers were sold the next year. The cost of these Snurfers ranged from ten to thirty dollars (Voje, 2005).

Dimitrije Milovich was the next individual involved for the expansion of snowboarding. After making a few runs on a cafeteria plate in his college years, Milovich designed a snowboard that was based on the same concepts as a surfboard in combination of the functionality of skis. This resulted in the startup of his company called "Winterstick" and produced a few different boards (Pelletier).

1977 marked a new chapter for the sport of snowboarding. After graduating from New York University, Jake Burton moved to Vermont to start his own company Burton Snowboards. Burton's company sold 300 boards in the first year. The design of the snowboard was similar to that of a Snurfer except Burton included bindings to hold the riders feet to the board. 1979

marked the first ever “World Snurfing Championship”. It took place at the Pando Ski Lodge in Michigan. Burton made the trek to enter this competition and after much protesting, was allowed to compete in a modified division. This particular race was viewed as the first snowboard competition and the beginning of competitive snowboarding. Burton’s company is now the largest snowboarding manufacturer in the world (Illicit, 2009).

In 1994, the sport of snowboarding made another large bound in popularity. In this year, the International Olympic Committee voted to recognize as an Olympic sport. Snowboarding made its first appearance in 1998 at the winter Olympics in Nagano Japan (Snowboarding, 2011). There were two events in the snowboarding division. The first was a large slalom, which like the ski slalom event, was essentially a downhill drag race where riders maneuver around flags. The second event took place on a half-pipe. A half pipe is a straight shot downhill with two hills of snow on each side. The hills launch riders into the air to perform free style tricks judged on originality, complexity, and gracefulness.

Interest in snowboarding continued to climb as a worldwide recognized sport. In 1997, ESPN featured the Winter X Games with snowboarding included as an event. The Winter X Games came to be from the great success of the Summer X Games. Both X Games were aired on ABC Sports and ESPN which added to the rapid popularity of snowboarding (Pickert, 2009).

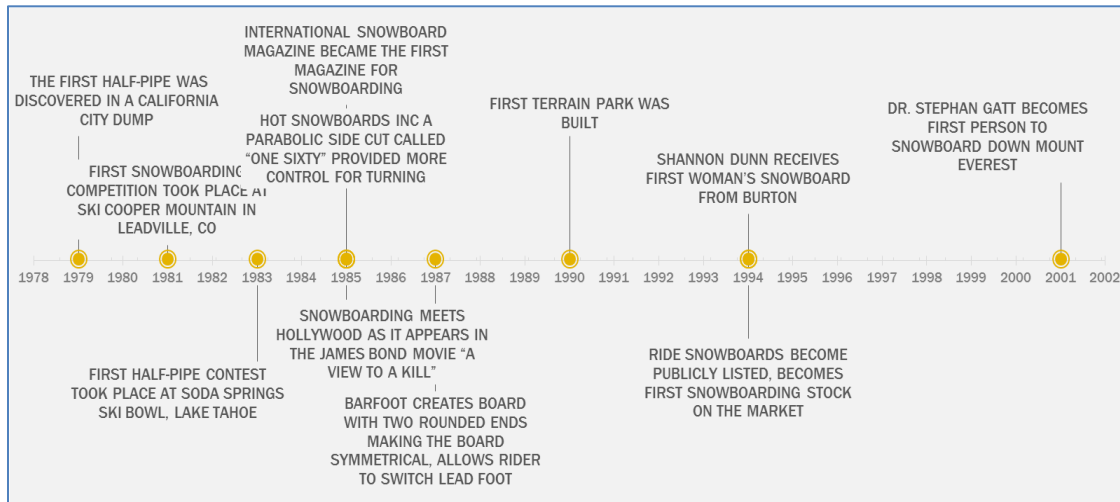

Figure 1: History of Snowboarding Timeline

## Snowboarding Today

Today, snowboarding has become widely accepted as a winter sport. It is an event in the winter Olympics, Winter X Games and can be found in other various winter sporting events across the country. Its popularity has grown so much so there are only four major resorts in the United States that do not allow snowboarding on its mountains: Taos, New Mexico, Deer Valley, Utah, Alta, Utah, and Mad River Glen in Vermont. (ABC News, 2010) Recently in 2012, Aspen Mountain allowed snowboarders to use their mountain and hosted the ESPN X Games. Since the emergence of snowboarding in the snow sport industry, ski resorts see “too much opportunity that almost all of them have terrain parks and half pipes for boarders to ride” (ABC News, 2010).

This noted opportunity can be justified by facts. In 2010 there were approximately 6.1 million snowboarders in the United States alone. About 20% of these snowboarders also ski. This translates into roughly 4.88 million additional winter sports enthusiasts who strictly snowboard and bring profit to snowboard friendly resorts (Statistic Brain, 2012). In addition to the established resorts profiting from the increased interest in snowboarding, established snowboard equipment manufacturers enjoy the profit. From 2011 to 2012 total snowboard sales reached roughly 437 million dollars (Statistic brain, 2012). Roughly 75% of snowboarders are

currently between the ages of seven and twenty four (Statistic Brain, 2012). The predominantly young snowboarding market provides reassurance for the continued growth and evolution of the sport.

## Components

### The Snowboard

The modern snowboard consists of two significant components; the laminate board and the bindings. The board is composed of eight different materials layered in such a way to promote flexibility and strength. The top-sheet is composed of a glossy or matte finish depending on the desired appearance of the board. The top-sheet also serves as form of protection for the board, providing a watertight seal and a surface to absorb scratches. Under the top-sheet is a layer of fiberglass which provides stiffness and strength to the snowboard's structure. At the center of the snowboard is a foam/wood core, most commonly composed of strips of poplar, obeche or birch. Other core materials are foam and aluminum honeycomb. A high molecular weight Polyethylene (P-tex) thermoplastic is used at the base of the board. This material is extremely easy to repair and bonds to wax to promote the reduction of friction. A metal edge composed of steel runs along the sides of the snowboard for efficient turning and carving. The steel is bonded to the fiberglass with a rubber foil commonly referred to as VDS. Steel inserts are used to attach the bindings to the board (The-House.com, 2013).

There are four types of mounting patterns to connect the bindings to the actual board. The most common are the 2-by-4 and 4-by-4 patterns. The 2-by-4 consists of two sets of twelve holes 4 centimeters apart across the board and 2 centimeters apart along the length. A 4-by-4 pattern has two sets of six holes separated 4 centimeters across the board and 4 centimeters along the length. Burton, a leading snowboard product manufacturer, has two patterns that are unique to its snowboards. The first being the 3D mounting pattern which consists of two sets of eight holes set

up in the shape of a diamond. The second pattern unique to Burton is the Channel. This system uses two slots, one in the front and back of the board, which allows for maximum customization of the binding placement (Wood, 2013). The aforementioned patterns can be seen in Figure 2.

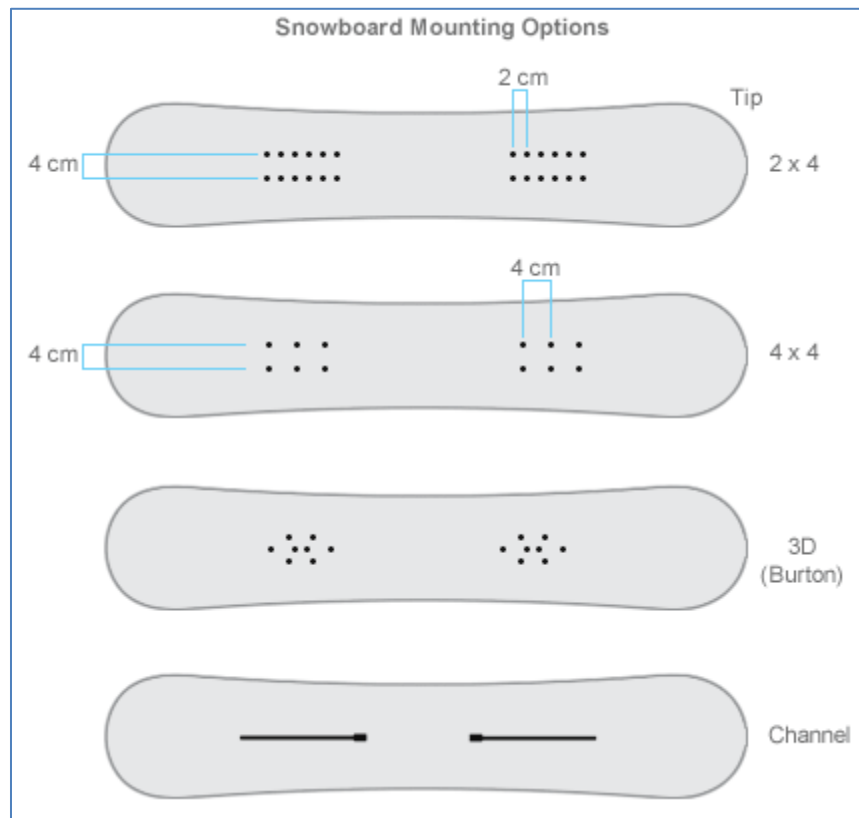

Figure 2: Snowboard Binding Mounting Patterns

## Bindings

Like the board, bindings are constructed from multiple materials, all serving a similar purpose. The baseplate is the area of the binding, upon which the rider steps. More expensive bindings are constructed of aluminum or composite materials (glass/nylon, carbon fiber, fiberglass) while less expensive base plates are constructed of hard plastic (ehow.com, 2013). Often times a layer of EVA (Ethylene-vinyl acetate), a closed cell foam/rubber which is impervious to liquid and tough at low temperatures, is attached to the baseplate to act as a shock dampening system (Intecfoams.com, 2010). Steel machine screws are used to attach the baseplate to the receiving mounting pattern on the board. There are two straps on most bindings,

one located at the toe and the ankle in order to prevent the rider from separating from the bindings. The actual strap material is a cheap ladder style plastic with EVA padding attached to side of the strap facing the foot. Receiving each of the straps is a ratchet composed of plastic for cheaper bindings and aluminum for higher quality bindings. The third major component of a binding is the high back plate. This vertical plate, attached to the baseplate, goes up the Achilles heel of the rider into the lower section of the calf muscle. This component is composed of hard plastic for lower quality bindings or a composite/aluminum material for higher quality bindings. Attached to the interior side of the high back plate (side in contact with the rider's leg) is an EVA pad to add cushion to an otherwise hard and uncomfortable material to have pressed to the back of rider's leg (ehow.com, 2013).

Since the start of the snowboard, bindings were used to distribute energy from the rider to the snowboard. Currently, there are four major types of snowboard bindings on the market: strap in, step in, flow in, and plate binding. The strap in binding is the original and most commonly used binding in snowboarding. This binding features a base plate to connect the binding to the boards, two sets of straps to station the boots on the board, and a high-back plate for controlling the board (ABC of Snowboarding, 2003). In 1995, K2 developed the first step-in binding, known as the clicker, for easy connection to the board. This binding used a step-in boot with a steel lip extruding from the toe, base plate, and high back plate to allow the boarder to easily step in and out of the board. This binding initially showed signs of revolutionizing the snowboard binding market; however, after further testing it showed minimal control of the board when compared to a traditional strap-in binding. This type of binding has become obsolete. The flow-in binding uses a base plate, tongue, and back plate lever. To insert the soft boot into the binding one simply has to push the back plate backwards and insert the boot. The back plate then locks back to its

upright position. The tongue can be tightened to the boot using similar straps as the strap-in bindings (ABC of Snowboarding, 2003). One of the disadvantages is that the straps located on the tongue are more difficult to adjust. The plate binding, similar to that of a ski binding, uses a base plate, steel bails, and a heel lever to connect the boots to the binding. It is compatible with only a hard boot. This binding is very responsive and is used mostly by Alpine Racers who want more control (ABC of Snowboarding, 2003). Figure 3 shows a spectrum of snowboard binding categories on the market.



Figure 3: Types of Snowboard Bindings

Like anything else, even the most current bindings have aspects that could be improved upon. Thegoodride.com, a snowboard equipment and apparel buying guide, rates bindings based on the following eight attributes: Flex, Adjustability, Comfort, Heel-Toe Response, Tip-Tail Response, Boot Support, Ratchet System and Shock Absorption (thegoodride.com, 2013). Many common complaints about snowboard bindings revolve around these attributes. The highest quality bindings will be comfortable, lightweight and have extremely sensitive response in the heel-toe and tip-tail planes while lower quality bindings will lack these qualities. Many inconveniences and safety issues stem from the design and set up of snowboard bindings. The rigid design of the snowboard makes it difficult to fall in a way to limit the injury received. Furthermore, unlike ski bindings, snowboard bindings require the ability to bend and reach the



ratcheting system on the strap to release the binding. If a deep powder rider were to fall head first into the snow with the board above the snow, it would be nearly impossible to release the binding, causing suffocation. On flat lands snowboard bindings pose a daunting inconvenience. When trying to travel on flatlands, most boarders will unstrap the rear binding, keeping the front foot attached to the snowboard, and propel themselves using their back foot. Not only is this an extremely inefficient way of maneuvering on flatlands, it is uncomfortable for the rider as it puts excessive torque on the ankle, knee and hip of the rider's front leg.

### **Rotational Bindings**

The increasing number of snowboarders has brought innovative ideas to the industry. The most recent idea has been a rotational mechanism that allows the binding to rotate on the board without having to unscrew the base plate. Unlike skiing, snowboarders are facing perpendicular to the bottom of the mountain when riding. Skiing has been around much longer than snowboarder. Thus, much of the terrain and riding lifts were designed for skiers. Riding on a ski lift causes strain and fatigue on the snowboarder's legs due to the perpendicular angle of the front boot while riding parallel up the mountain. Currently, four notable rotational mechanisms for snowboard bindings on the market are: the Swivler, Twisted Bindings, X Turn, and Quick Stance.

The Swivler is an attachment that goes between the bindings and the snowboard. There is a chord attached to the calf of the rider. To engage the Swivler simply pull on the chord and rotate snowboard boot and binding. The Swivler has two locking positions: a set angle determined by the rider when mounting the unit on the snowboard and another facing parallel to the board (Jump USA, 2009). The X Turn is a complete binding system that allows the rider to quickly adjust the angle of the binding by lifting a handle behind the binding. After the handle is lifted the heel end will rise up off the board and the binding is free to rotate. Once the desired

angle is reached the rider applies pressure to the heel of the binding and the unit will lock in place. This design allows adjustment of the binding angles for experimenting to find desired angle and rotating front foot when “skating” on flat surface and riding on a ski lift (Newton, 2007). The quick stance is an attachment that goes between the bindings and the snowboard. There is a chord attached to the calf of the rider. To engage the Quick Stance simply pull on the chord and rotate snowboard boot and binding. This unit allows rotation of 360° in 5° increments and is compatible with all types of hole patterns: 4-hole, 3-hole, and EST boards (QuickStance, 2013).

## **Methodology**

### **Introduction**

The goal of the project was to design, create and test an alternative means to the snowboard riding experience. The hope is for our two-plate design to allow a thrust bearing to be attached between the snowboard and the binding, allowing for a freely rotating snowboard binding within a limited degree of restriction. This apparatus should not increase the risk of injury while snowboarding nor should it increase the seriousness of injuries.

The following sections of the methodology delineate the steps to reach our final prototype. The succeeding sections will contain the research to previous designs of a rotating binding, prototypes and test designs. These tests will be used to test our designs as well as explain why we chose one over the other.

### **Research**

The problem statement proposed to the project group was to create an alternative riding experience for the sport of snowboarding through the use of free rotation of the feet. Solving this problem statement entails gathering information on the sport of snowboarding, the mechanics

involved in riding as well as the equipment and how it functions. Our first step was to research snowboarding as a sport by breaking down this step down into three categories; the history of snowboarding, current snowboarding, and current alternative designs. In doing so, we were able to understand important concepts such as where/when snowboarding emerged as a sport, how snowboarding effects today’s economy and what has already been proposed as an alternative to the accepted snowboard/binding design.

The next step in our research was to analyze the fundamental basics of our problem statement in order to obtain a better understanding of how the project goals would be met. The variable within this problem statement is the rotational aspect of the alternative design. While designing a functional apparatus is our main goal, several sub-objectives come into play. In creating a new rotational binding, we must consider its functionality as well as its reliability, compatibility, marketability and level of safety.

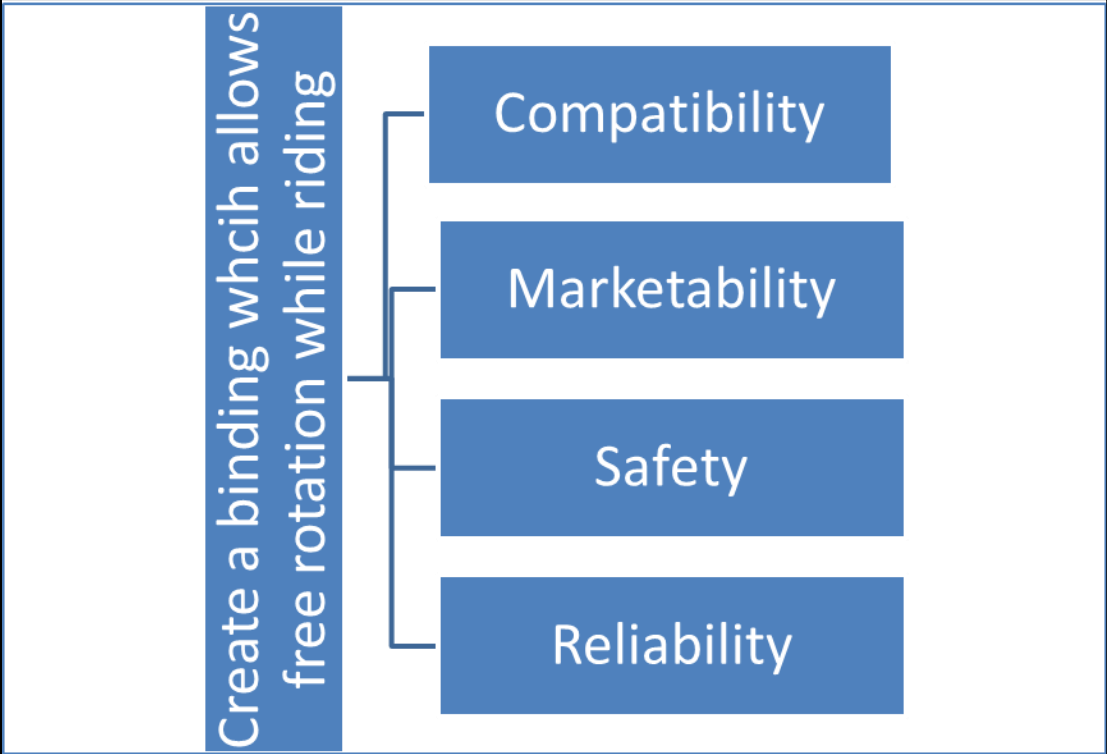

Figure 4: Breakdown of Problem Statement

While researching we were required to not lose sight of our objectives. In order to do this, each member of the group analyzed a number of patents for rotational binding designs. A total of six patents were analyzed. We extracted information such as both positive and negative design aspects, feasibility and marketability. These findings will be expanded upon and deciphered later on in this section.

In addition to researching literature, we conducted first person interviews with various members of the WPI and snowboarding community. As a group we met with an employee of Strand's Ski Shop in Worcester MA. While at Strand's, the employee explained to us his thoughts on a rotational binding and what we would have to take into account if it was going to be successful. Not only that, this employee allowed us to look at certain riser plates and various types of bindings that our design could be based off of. In viewing these products, it was concluded that our binding apparatus could reach a thickness over an inch, and not drastically impact how a board responds. A second interview conducted was with Professor Chris Brown of Worcester Polytechnic Institute. Professor Brown has advised countless winter sport (snowboarding and skiing) MQP projects and the information he provided us on how to test and what we would need to do to make our design a success was invaluable.

## **Patent Reviews and Analysis**

### ***Snowboard Binding Mount Assembly***

US Patent 6,450,511 B1 is a rotational snowboard binding system that allows the rider to adjust the angles of both bindings between rides down the mountain. This patent uses a two plate system that goes between the snowboard and the bindings. The bottom plate is attached to the board using four screws. The connection of the top plate to the bottom plate uses threads on the outer wall of the bottom plate and threads on the inner wall of the top plate. The top plate screws

onto the bottom plate in a clockwise fashion. Surrounding the bottom plate are incremented holes, shown in Figure 5, which allow for a spring-loaded pin located on the top plate to lock into place.

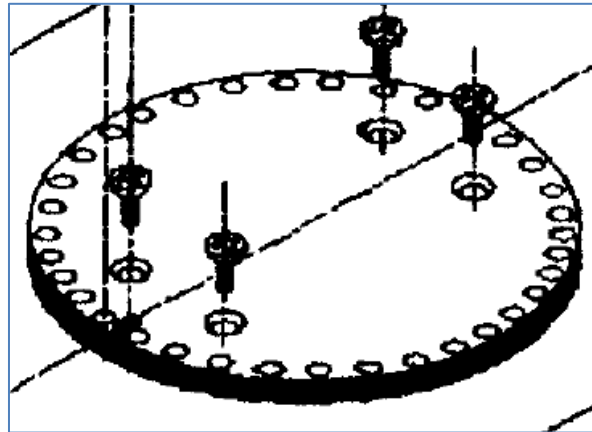

Figure 5: Bottom Plate of Rotational Snowboard Assembly

The top plate consists of eight holes which allow for the mounting of the snowboard bindings. This device gives the rider more options when choosing the width between their feet. The top plate connects to the binding using the universal discs provided with the binding. An exploded assembly drawing is shown in Figure 6.

The design of this rotational snowboard provides many benefits. The enclosed system of the top plate screwing into the bottom seems to provide good protection from weathering. The spring-loaded pin prevents the top plate from rotating and is locked in one of the incremented holes on the bottom plate. There also exists a stopping block which prevents the top plate and bottom plate from separating completely. The design is simple and user friendly. It also provides the rider choices when determining the width of the feet. One of the drawbacks from this design is that the bottom plate only works for 2-by-4 or 4-by-4 snowboards. Some of the new mounting systems such as the channel, by Burton, would not be compatible with this assembly. Also, the setup has no way to tell which angle of preference the binding is engaged in between increments. The assembly provides no visual aid for determining the preferred angle.

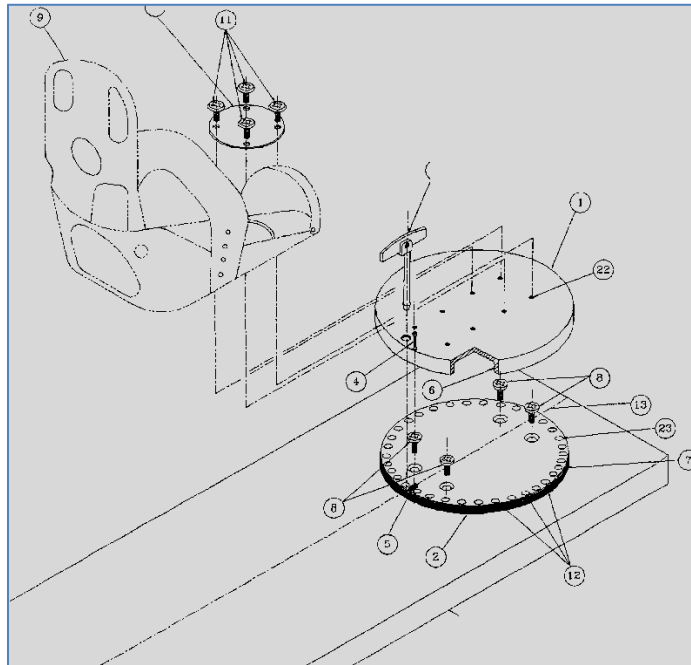

Figure 6: Exploded Drawing of US Patent 6,450,511 B1

After researching various patent designs and further analyzing current binding assemblies, the group was confident that the design would be a success. The addition of a rotating element will not cause any necessary features of a conventional snowboard binding to diminish. Turning and stopping will still be practical. One can think of the rotation as occurring on one axis parallel to that of the snowboard. The heel and toe turning motion implements forces on a plane orthogonal to the rotational plane. This 90° relationship prevents the rotation of the rider's feet from hindering the ability to turn and perform heel/toe stops. While the feel of a rotating binding may present an initial challenge to the rider to become accustomed to, it will not take away from any of the basic and most important functions of a snowboard binding.

## Preliminary Testing

### Prototype 1

The first trial for a freely rotational binding within a 180 degree angle to the board consisted of: a skateboard, snowboard bindings, heavy duty zip ties, and two bar stool swivel

bearings as shown in Figure 8. The first step in designing this prototype was to attach the bindings to the swivel bearings as shown in Figure 7. Notches had to be cut into the bindings to allow the heavy duty zip ties to strap the bindings down without affecting how the boot fit in the binding. The other side of the bearing was screwed to the top side of the skateboard. Each binding and bearing pair was positioned as far apart as possible in an attempt to make the stance on the skateboard similar to that of a snowboard.

Each member of the group strapped into the prototype and rode it down a slight decline plane of asphalt in a vacant parking lot. The goal of this test was to feel how a snowboard would function with freely rotational bindings. By attempting turns down the declined hill and while operating the rotational bindings, the desired result was to understand the benefits and drawbacks that are associated with free rotation. After conducting this test, we concluded that this setup was not ideal for what was hypothesized. Skateboards are designed to turn when pressure is applied either side of the board. This causes a flex in the trucks, which allows the skateboard to turn. Due to the excess flex in our prototype, there was no gain in the control over the skateboard. This initial experiment did not allow for a good grasp of how a snowboard with freely rotational bindings would function. It was determined that although this prototype was not ideal, a similar setup could be incorporated to get the true riding experience of a freely rotating binding.



**Figure 7: Barstool Swivel Bearings**



Figure 8: Prototype 1

### Prototype 2

This prototype is very similar to the previous setup. The bindings and bar stool bearings were removed from the skateboard and installed into a piece of plywood that was four feet long by one and half feet wide. The size of this plywood more closely resembled the size of a snowboard. To make sure the screws did not go through the plywood, both lock washers and washers were used as spacers. The lock washer also added a more secure attachment of the bearings to the plywood. The bindings and bearings were spaced farther apart than the previous prototype to more closely resemble a snowboard like stance as shown in Figure 9.

Again, each member of the group stepped into the bindings to get a feel for the new setup. The hope for this new setup was to closer replicate a true snowboarding experience, with the addition of the rotating bearings. An additional goal of this prototype was to use it for baseline testing for flex of the board when forces were applied to it. This prototype worked as it was intended to. It gave the group a more realistic idea of what it would feel like to ride a snowboard with freely rotating bindings down a mountain.





Figure 9: Prototype 2



Figure 10: Prototype 2 Binding Connection

## Design

### Design Constraints

Upon completion of research including interviews and existing product analysis, the group came to the conclusion that the following design constraints were to be used as a guide for finalizing a functional prototype.

1. Design will provide rotational freedom limited to no more than 160 degrees
2. Design will provide comparable applied loads to a snowboard

3. Design will provide features for weather resistance
4. Design will be compatible with existing four-hole interface (4-by-4 and 4-by-2 centimeter) of commercial snowboard
5. Design will be compatible with existing four-hole interface (4-by-4 and 4-by-2 centimeter) of commercial binding disc
6. Design will increase the height of the bindings no more than 1.25 inches above the snowboard
7. Overall diameter of design will not be greater than 9.25 inches (based on minimum waist width of commercial snowboard)

## **Design Features**

### ***Thrust Roller Bearing***

After the group performed further research on bearings and discussed options with bearing specialists, we decided that a thrust roller bearing was the best option for this design as shown in Figure 11. Thrust roller bearings are made to handle massive amounts of compressive forces from machine components. Thrust forces are the most prominent forces present in the binding-board connection as one is riding. The group agreed upon a 180-by-140 millimeter (OD-by-ID) thrust needle roller bearing as shown in Appendix E. This bearing allowed the group to finalize the overall diameter and heights of the apparatus and more specifically the top plate.

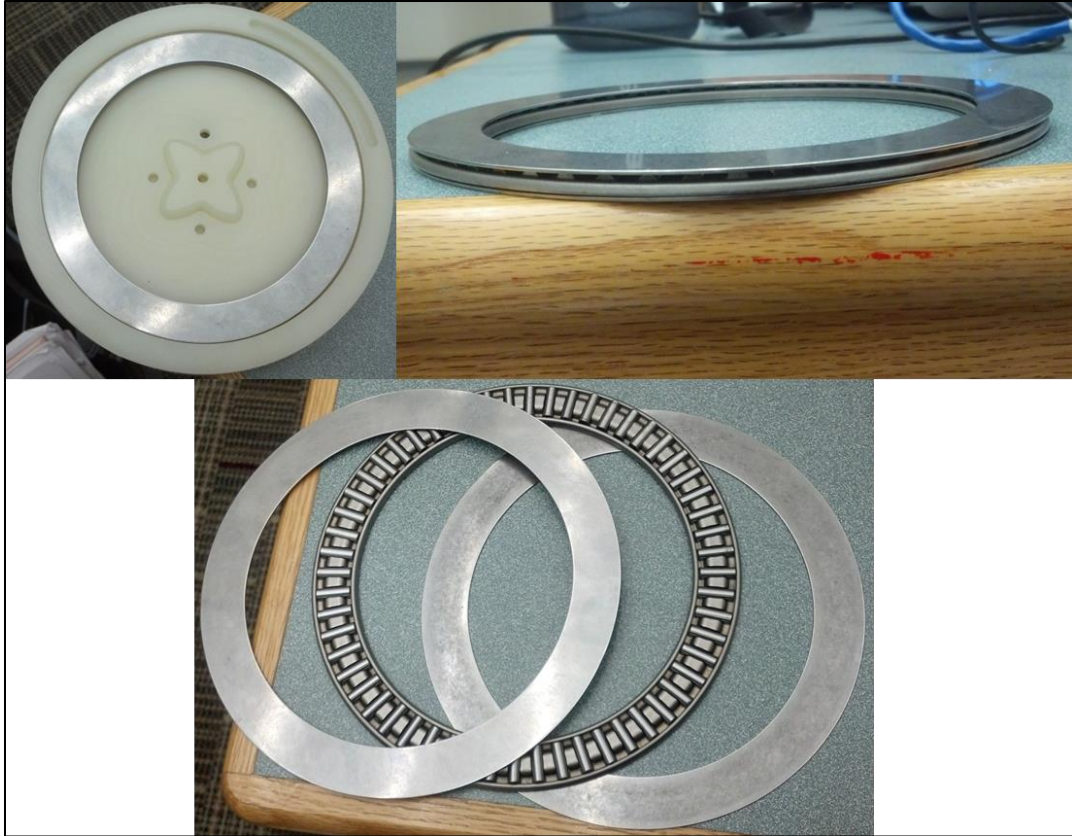

Figure 11: Thrust Needle Bearing/Washer Assembly

### *Attachment Mechanisms*

Our initial design did not include any mechanism to attach the bottom plate to the snowboard while the top plate is in place. This was a crucial oversight that we rectified. A 1” diameter hole was bored through the top plate. This hole was offset 1.11 inches from the center of the top plate and centered between two of the binding connection holes as shown in Figure 12 in addition to Appendix E. With the limiting pin removed from the channel and the binding detached from the top plate, this hole provides the rider with the ability to attach the rotating retrofit to his/her snowboard while keeping the design fully assembled.

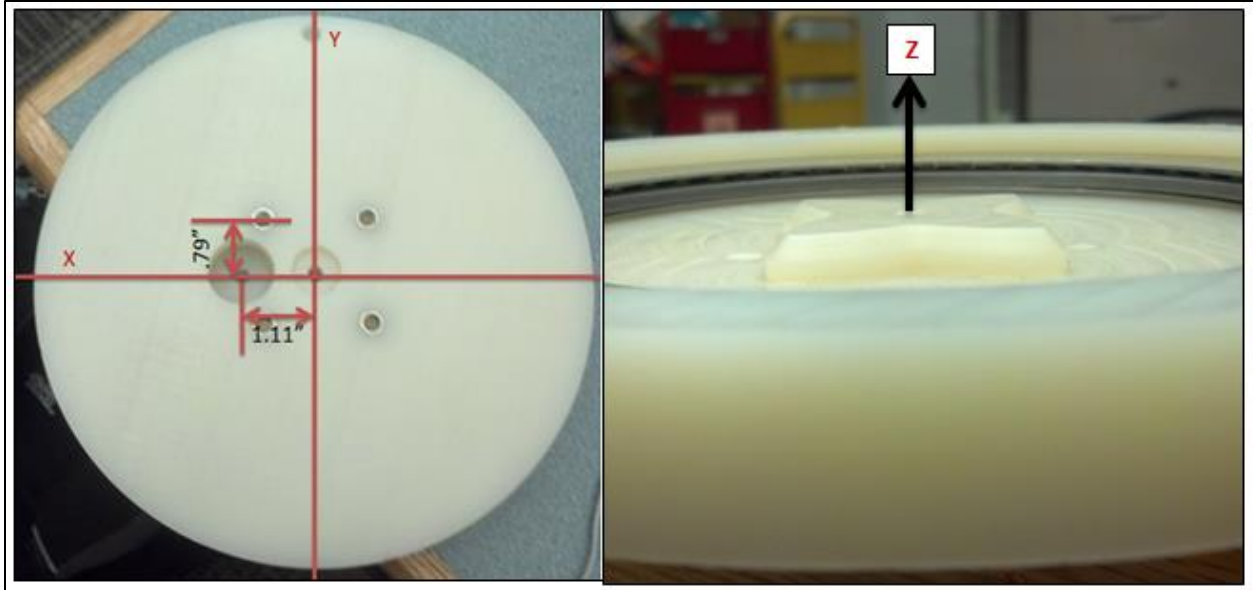

Figure 12: Plate Axis'

### ***Binding Mount Hole Pattern***

As seen in Figure 12, a four hole 4-by-4 centimeter pattern was implemented as opposed to an initially proposed eight hole 4-by-2 centimeter hole pattern. This pattern was agreed upon to add simplicity to the design. As this apparatus used a center “Z” axis of rotation positioned directly at the origin of the X-Y plane, the possibility of offsetting binding placement on the top plate was not feasible as it would create a rotational unbalance, making rotation while riding difficult. The four-hole design will fit 4-by-4 and 4-by-2 centimeter hole patterns and will, in turn, be compatible with most bindings. Each of the four holes were press fit with a stainless steel M6x1x8 millimeter threaded insert. With the addition of the press fit inserts, the user can attach their bindings to the top plate using their current hardware as binding screws are universally countersunk M6x1.

### ***Structural “Star” Support***

To add structural support to the connection between the top and bottom plate, the group added additional material encompassing the center hole bore of the bottom plate to offset the boring out of .25 inches underneath this structure. The bored-out region provided the attachment

nut of the center bolt clearance, shown in Figure 14 and Appendix E. In order to maximize structural integrity, avoid adding excessive weight and imposing additional material on the four bottom plate board attachment holes, the group used a four point star shaped pattern shown in Figure 13. This shape was created by converging two 2.6-by-1.1 inch (maximum length and width) ellipses and extruding them up .25 inches in the positive direction along the Z axis. As shown, the design maximizes the structural support of the material by extending the points of the star between each of the four holes and provides sufficient clearance to fit a .75 inch washer for each hole. This washer will be installed with the provided M6 screws to add surface area that the forces from the screw attachments will be displaced across. The height of the star does not interfere with top plate's bottom surface as its height is slightly less than the overall height of the bearing/washer combination by which it is surrounded.



Figure 13: Structural Star Design

### ***Limiting Channel***

In order to limit the rotational angle of our design, we decided to incorporate a channel in the sidewall of the bottom plate. A threaded, spring-loaded pin was screwed through a press fit insert on the outer edge of the top plate which when engaged, will fit into the channel. As the top plate rotates and gets to a specified angle on either side of the Y axis, the extended pin cylinder

will hit the edge of the channel, therefore limiting the rotation. Initially, the channel was set to only allow a maximum rotation of  $30^{\circ}$  on either side of perpendicular, resulting in a total allowable rotation of  $60^{\circ}$ . However, the team felt that this constraint of  $60^{\circ}$  restricted the overall exploration of the apparatus' capabilities. Before the product was tested on a mountain, the channel was extended  $50^{\circ}$  on either side of the Y Axis to increase the rotation angle to  $160^{\circ}$ . This allowed for multiple angles of rotation to be tested through the use of channel inserts as discussed in the section titled "Mountain Testing" subsection "Apparatus Components".

### *Locking Angles*

In addition to the channel, a single M6 hole was drilled into the sidewall on both sides of the channel. These two holes were located  $90^{\circ}$  away from the center of the channel ( $90^{\circ}$  away from the Y axis). These holes allowed the rider to "skate" (move across flat land) more easily by pulling the pin from the rotation channel and inserting it into either of the two holes (depending on the rider's stance aka. goofy or regular). This alignment lock did not only reduce stress on the rider's ankle and knee while moving on flat land but also prevented unwanted rotation from occurring during this process. Additionally, this feature decreased the amount of stress put on the ankle and knee as the rider ascended the mountain in the chair lift. The weight of the snowboard was on the same vertical plane as the leg. Torsional moments on the knee and ankle decreased significantly as discussed in the section titled "Mountain Test" subsection "Chair Lift".

Having the ability to rotate one's feet while riding a snowboard can have many benefits, such as tighter turning and less upper body motion creating a greater sense of balance. However, while going over certain terrain (based on the rider's preference) one may wish to ride in the conventional sense with their feet locked in at set angles. In order to make our apparatus more

appealing and universally accepted, we felt that the rider should have the ability to rotate their feet and lock in their angle all within the design of a single apparatus. To fulfill this design constraint, the group implemented a second pin located along the X axis,  $180^{\circ}$  from the spring loaded limiting pin. This second pin is spring loaded, but unlike the first pin, has the ability to lock in the engaged/disengaged position. A hole was drilled in the bottom plate directly below this second pin such that the pin, when engaged, will lock the top plate into a position at  $0^{\circ}$  of rotation. The rider can mount their bindings at a preferred angle on the top plate comparable to their foot position on a conventional, non-rotating binding. This additional design feature will allow the rider to lock the binding position if rotation is not desired, to therefore make this product more appealing as a universal riding tool capable of being operated on any terrain.

### ***Center Bolt***

Initially, the group determined that a press fit design to connect the top and bottom plates would be sufficient. After further research and a bearing design change, the group came to the conclusion that a center bolt along the Z axis of rotation would be necessary to hold the top and bottom plates together as shown in Figure 14. In order to do this and still have the ability to lay the apparatus flush with both the binding and the board a .25 inch counter bore on the bottom face of the bottom plate and the top face of the top plate were implemented into the design. This design enhancement allows a machine screw with a head/nut that is a maximum of .25 inches thick to be utilized as the center bolt. A downside to this design is that as the top plate rotates, there is a possibility that the bolt/nut connection may become loose due to the threading of the bolt. This design flaw is discussed in section titled “Mountain Test” subsection “Apparatus Components”.

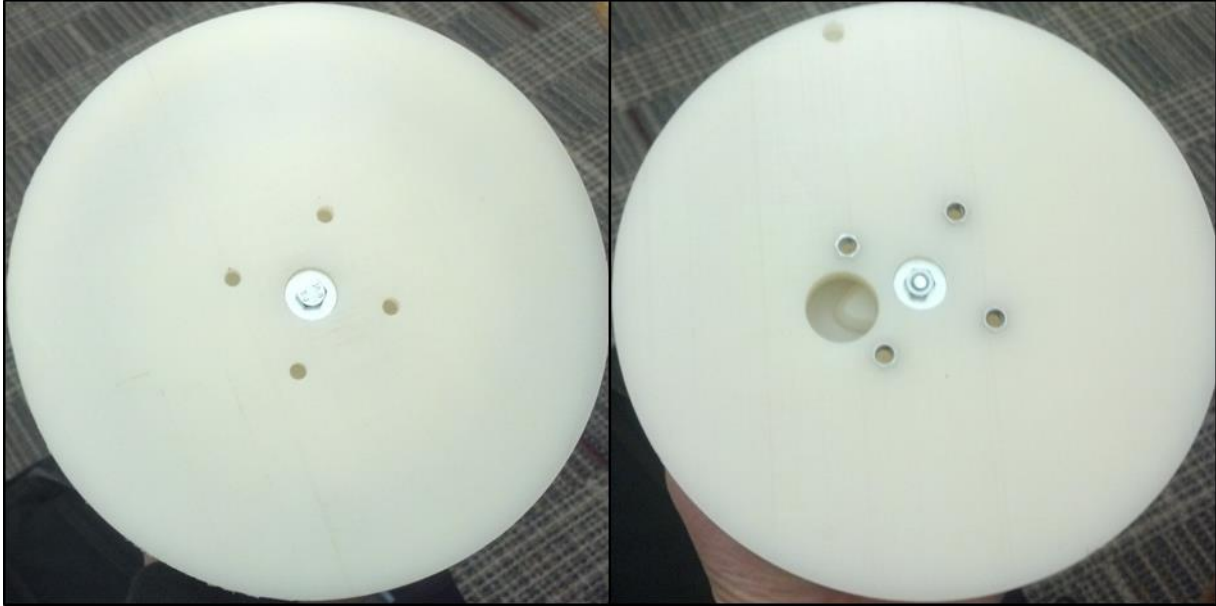

Figure 14: Center Bolt

### ***Plate Material***

As previously mentioned, snowboard bindings can be composed of many different materials depending on how much the rider is willing to spend. Based on the design constraints, using a common binding material for an attachment would be necessary. To keep expenses down while keeping the strength and durability of a snowboard binding, Nylon 6/6 was chosen for the top and bottom plate of this apparatus.

Aluminum is one of the most commonly used materials for high-end snowboard bindings. This selection is a result of the strength and durability associated with aluminum parts as well as its light weight qualities. It has low coefficient of thermal expansion and does not become brittle in cold temperatures. Another key property that aluminum has is that it does not rust. As the material selected will be subject to snow and other weather conditions, this is a very important factor in the selection process. However, as the top and bottom plate will contact each other, a low coefficient of friction is required. Aluminum has a higher coefficient of friction at 1.05, compared to nylon with a friction coefficient of .25, making it not ideal for this application (Cobden, 1994).



Another material that was investigated was High Density Polyethylene (HDPE). This material is inexpensive and has a high impact resistance of 5800 psi, which is a good property for the top and bottom plates as sudden violent movements during turns or forces when landing are expected. HDPE is also an easily machined plastic in the manufacturing industry. It does however have a few flaws in its other mechanical properties. HDPE has a high thermal expansion rate ( $12 \times 10^{-3}$  in/in/ $^{\circ}$ F) which is not ideal for this apparatus. If the material shrinks too much due to the cold temperatures, the free rotation could be hindered or stopped all together. It also has poor weather resistance, meaning it absorbs water at an amount equal to 3 percent of the total mass over a twenty-four hour period, compared to Nylon's 0.8 percent. This swelling can disrupt the dimensioning of the plates and therefore prevent rotation. HDPE also has low strength and stiffness attributes (5800 psi), neither of which are ideal (Ides, 2013).

The other alternative to Nylon was Ultra High Molecular Weight Polyethylene (UHMW). This material has a high resistance to abrasion, which is very beneficial, as the two plates will rub against each other at certain points. It also has a lower coefficient of friction than Nylon, rated at 0.16. However, UHMW has an impact strength of 790 psi, making it less desirable for a snowboard application. UHMW has high weather resistance causing it to not absorb water and expand. Another very beneficial mechanical property of UHMW is that it has a low thermal expansion rate ( $2 \times 10^{-4}$  in/in/ $^{\circ}$ F) and does not become brittle at low temperatures. The down side to the selection of this material is its low impact strength (Professional Plastics, 2013).

Nylon 6/6 has all the mechanical properties that are required to maximize the effectiveness of the top and bottom plates of this binding attachment. This material has a very high wear and abrasion resistance. This is ideal for materials being used for snowboarding since the parts will encounter many different weather conditions as well as other foreign particles like

dirt, rocks, sticks and potentially other snowboards or skis. Nylon 6/6 can be easily machined and fabricated as well. From the cut sheet that was provided while purchasing the material, it states that the Nylon 6/6 has a high compressive strength of 13,000 psi as well as a flexural strength of 14,500 psi and a modulus of Elasticity of 410,000 psi making this a very strong and stiff material. As it will be subject to cold temperatures, the coefficient of thermal expansion must be low so the dimensions of the part are not affected. Its expansion coefficient is  $4 \times 10^{-5}$  inches per inch per  $^{\circ}\text{F}$  (in/in/ $^{\circ}\text{F}$ ). Another benefit of Nylon 6/6 is that it has a low absorption rate of water. It absorbs 0.8% of the piece's weight in water over a twenty-four hour period. This apparatus will most likely not be used or subject to liquid for that length of time, making the amount of water absorbed during a normal snowboarding session nearly zero percent. Finally Nylon 6/6 has a low coefficient of friction at .25, so there will be very little frictional resistance if there is any contact between the top and bottom plates, and therefore will not hinder the rotation of the apparatus. Additionally, Nylon 6/6 was significantly cheaper than the aluminum, stronger than UHMW and HDPE therefore would provide the optimal material for the most feasible cost (NYTEF Plastics, 2013).

## **Machining**

Once the computer aided modeling of our prototype was completed with dimensions using SolidWorks (See Appendix E for all SolidWorks drawings), the parts were imported into ESPRIT. Based on the dimensions of the parts, milling was used for machining the top and bottom plates. Tool paths were created by the program based on cutting features and tools defined by the group.

The 0.75 inch nylon used for the bottom plate began with a 10.5 by 12 inch rectangle. A Washburn Shops band saw was used to cut the stock to an 8.5 inch square shown in Figure 15. This process was done with the 0.5 inch nylon used for the top plate with 11.5 by 12 inch

dimensions as well. Reducing the cutting stock of the parts helped minimize vibrations during the milling process. The scrap nylon also served as a base when cutting through the material.



**Figure 15: Washburn Band Saw**

The 8.5 inch square nylon stock of .75 inch thickness was fixed into the CNC milling machine underneath the 0.5 inch nylon scrap base. Four collet fixtures were used, one in each corner of stock, to hold the stock in place along with double sided tape between the stock and nylon base. The collet fixture assembly is shown in Figure 16.

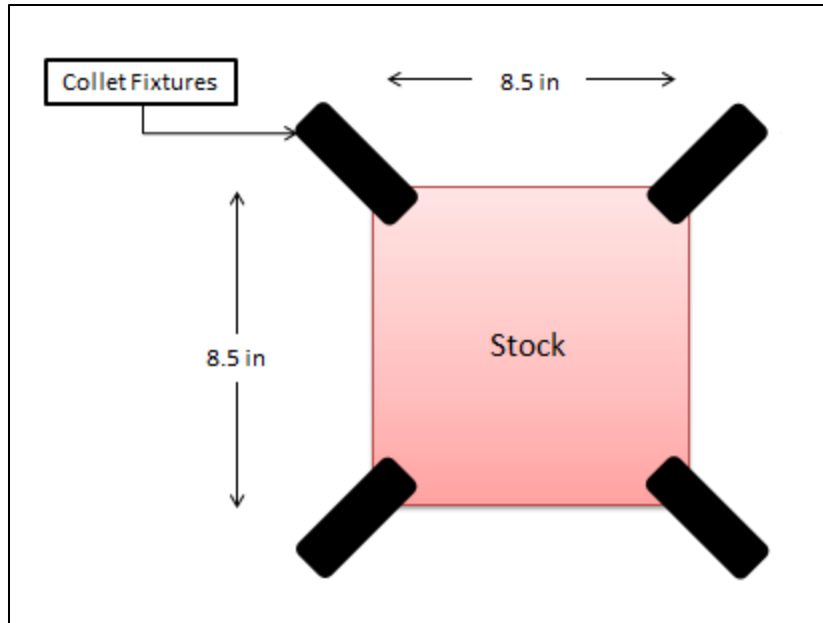

Figure 16: Collet Fixture Assembly

Once the stock was fixed into the machine, a probe was used to create coordinates around the stock (origin located in the center of the stock). Necessary tools for were added to the machine and lengths were measured. Since nylon is a weaker material than metals, a higher feed rate and lower spindle speed was needed to prevent melting the material during the milling process. A feed rate of 36 feet per minute and spindle speed of 1500 revolutions per minute was used for cutting features. An air compressor was used as a substitution for coolant to keep the chips away from the tool. Even though nylon is extremely weather resistant, it can still absorb liquid, causing it to expand and contract. While the effects of the expansion and contraction are negligible in mountain conditions, spraying coolant on the stock while machining could have induced enough absorption and expansion to cause our part to be machined to improper dimensions. Completed parts are shown in Figure 17. Further details of the manufacturing process can be found in Appendices A and B.



Figure 17: Machined Top (Right) and Bottom (Left) Plates

### Assembly

After the machining of the top and bottom plates were completed, the apparatus had to be assembled. The first step in the assembly was to insert the stainless-steel, M6-1 threaded inserts into the top plates. These inserts were press fit 8 millimeters into the top plate at the four, 7.9 millimeter holes previously drilled. These inserts will serve as an attachment point for the binding disc to the rotational apparatus. In addition, press fits were installed on top face's outer circumference for the spring loaded limiting pin and the locking limiting pin. The inserts have a hexagonal top face diameter of 7.92 millimeters. This dimension allows the press fit to sit flush on the top plate while a 7.89 millimeter circular base allows it to be partially placed in the pre-drilled hole. An Arbor Press was used to press fit the inserts into place as shown in Figure 18.



**Figure 18: Press Fit of Threaded Inserts**

After the inserts were press fit in place, the washers and thrust bearings were placed into the housing created by the bottom plate. Once the bearing and washers were installed, the top plate was placed on the bearing system. Next a .75 inch stainless-steel washer was placed on the M6 by 23.65 millimeter cap screw (this dimension was custom cut to fit our required height), which was then inserted through the bored hole through the star structural feature on the bottom plate. A second .75 inch steel washer was placed within the .75 inch bore on the bottom surface of the bottom plate. An M6 hex nut was tightened down along the center bolt to hold the top and bottom plates together. The hole for the limiting pin was then lined up with the machined channel. Once the hole and the track were aligned, the spring loaded limiting pin was screwed in place. Referring to Figure 12, the limiting pin was placed in the hole located on the outer edge of the top plate on the Y-axis. Finally, the locking limiting pin was screwed into place 90° from the X-axis on the outer edge of the top plate.

## Strain Test

### Materials and Methods

In order to better understand the effects that a rotating plate apparatus would have on the snowboard, the team designed and executed a strain test. The following materials and products were used to conduct this test:

1. One snowboard
2. One snowboard binding
3. One snowboard boot
4. One rotational apparatus
5. Four 120 Ohm Strain gauges
6. Four sets of Black/White/Red wire
7. One amplifier
8. LabVIEW vi set up for torsional and bending strain readings
9. One testing foot and associated torque wrench
10. 10 lb. and 25 lb. Olympic weights
11. One 13 inch aluminum clamp machined with  $\frac{1}{4}$ "-20 screw holes

First, the X and Y axis' of the snowboard were determined by measuring the center lines of each plane. Once reference points were determined, four strain gauges were attached to the snowboard, two to measure bending strain and two to measure torsional strain. These strain gauges were located according to their designated purpose. A red wire was then soldered to the positive terminal of each strain gauge while a combination Black/White wire was soldered to the negative terminal of each gauge as shown in Figure 19. The group had to ensure that each strain gauge was wired exactly the same in order to avoid obtaining false results. Once all wires were soldered, a layer of hot glue was placed over the strain gauge and solder connection so as to prevent any possibility of a disconnect while testing. An aluminum plate was machined to act as a clamp to provide a cantilever set up for this test. Two  $\frac{3}{8}$  inch holes were machined on either end of the aluminum plate to match the hole pattern of the threaded plates built into the Experimentation Lab tables as shown in Figure 20. The board was clamped down and

cantilevered to promote optimal mobility for bending and torsion from applied force. A snowboard boot with a prosthetic foot and leg was used as the test “human” assembly as shown in Figures 22 and 23.

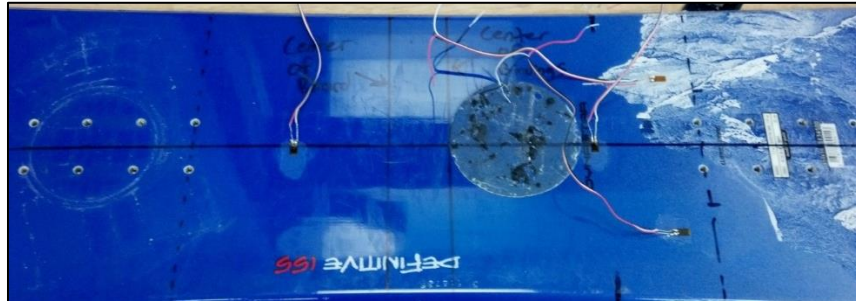

Figure 19: Strain Gauge Location

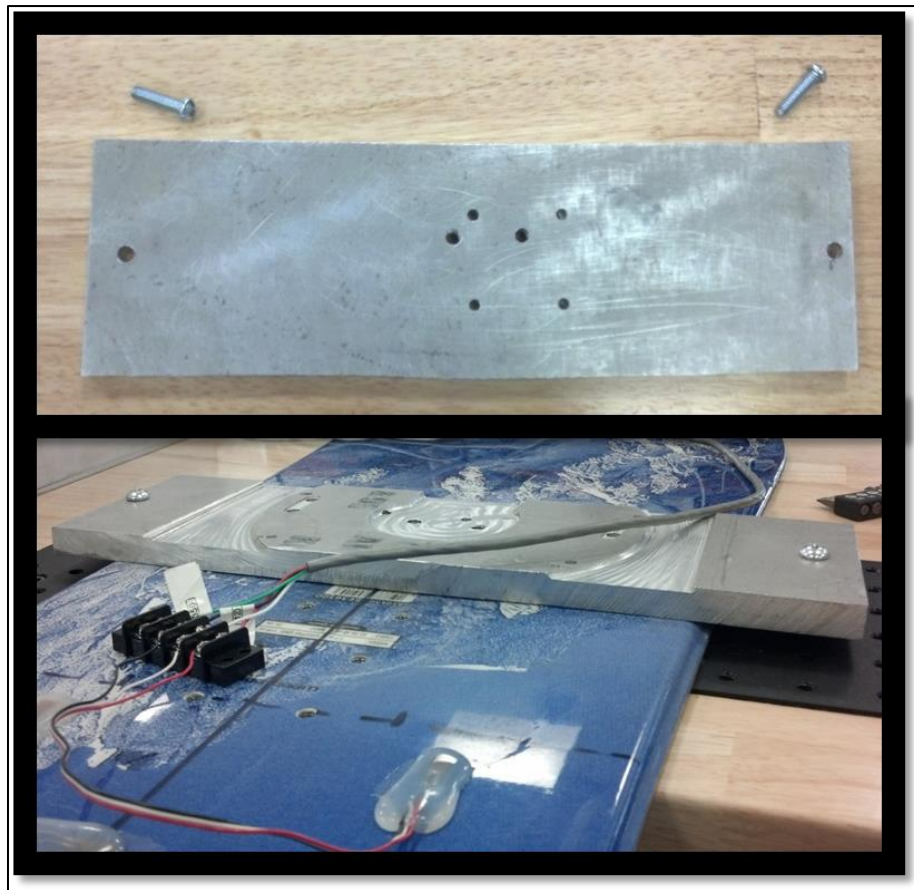

Figure 20: Aluminum Plate





Figure 21: Boot/Foot Apparatus



Figure 22: Testing Foot

After a simple trial test to ensure that our LabVIEW program was effectively reading our strain gauges and outputting realistic data, we were able to begin testing. In the first set of tests, the rotating apparatus was not incorporated in the overall structure of the snowboard. The binding was attached directly to the snowboard in the conventional manner. In order to test for

bending stress, measurements were taken from the Right strain gauge. Three separate measurements were taken: utilizing the dead weight of the boot and metal foot, adding a ten pound weight to the leg of the prosthetic foot, and adding a twenty-five pound weight to the leg of the prosthetic foot as shown in Figure 23. For each test a separate Excel file was created through LabVIEW's "Write to Spreadsheet" feature. To test for torsional strain, a torque wrench was attached to the leg as seen in Figure 24. This gave us an offset from the longitudinal axis to attach weight and promote a moment, causing torsional forces on the board. To isolate torsional forces, a support was placed under the snowboard, preventing any bending due to the cantilevered nature of the system. Two conditions were tested for torsion: a ten pound weight on the torque wrench and a twenty-five pound weight attached to the torque wrench. Again, all results were exported to an Excel spreadsheet through LabVIEW.



**Figure 23: Bending Strain with Conventional Attachment**

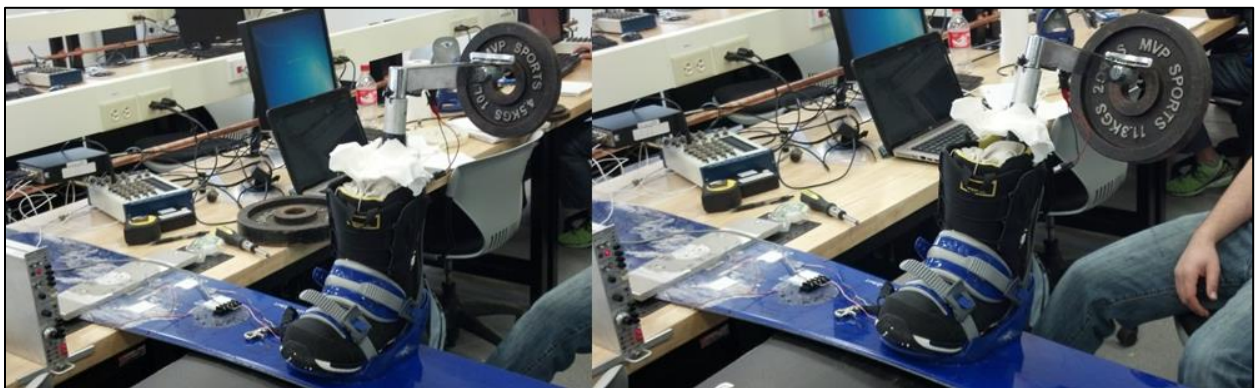

**Figure 24: Torsional Strain with Conventional Attachment**

Once all conventional conditions were tested, the rotating apparatus was attached. The binding was fastened to the top plate and testing began. The tests run were the same as for the conventional snowboard design. Three tests were run to observe bending strain while two were run to observe torsional strain as shown in Figures 25 and 26. All tests results were recorded to an Excel file.



Figure 25: Bending Strain with Rotating Apparatus



Figure 26: Torsional Strain with Rotating Apparatus

## Results and Conclusion

Upon completion of the tests all data was stored in separate excel spreadsheets. Each data set was then averaged out to get an approximate value for each condition. Figure 27 is a compilation of each test, showing the average strains for all ten various conditions.

Test #	Forces	Apparatus (with Boot, Binding, Foot)	Rotator	Weight (LB)	Moment (in-lb)	Average Strain
1	Bending		No	7.5	131.25	7.393
2	Bending	10 lb	No	17.5	306.25	31.263
3	Bending	25 lb	No	32.5	568.75	80.509
4	Torsion	Wrench, 10 lb	No	10	275.86	9.428
5	Torsion	Wrench 25 lb	No	25	689.66	38.354
6	Torsion	Wrench, 10 lb	Yes	10	282.84	11.643
7	Torsion	Wrench 25 lb	Yes	25	707.11	38.176
8	Bending		Yes	10	175	9.858
9	Bending	10 lb	Yes	20	350	35.729
10	Bending	25 lb	Yes	35	612.5	86.702

Figure 27: Chart of Bending and Torsional Strain Data

When comparing bending strains between conventional attachment and attachment through the rotating apparatus, it is seen that the rotating apparatus does cause a slight increase in the measured strain due to the additional 2.5 pounds that each rotating apparatus adds to the testing system. The additional weight increases the downward force on the cantilevered system, causing a higher level of measurable strain. However, the change in bending strain between a conventional snowboard binding and the prototype is very minor compared to the loads applied to the board.

Since every snowboard is comprised of different materials and thicknesses, researching a modulus of elasticity for a snowboard was not an option. To estimate a bulk modulus for the test board, deflection data was recorded by the group during the various bending tests. Using the deflection equation of a cantilever beam, the group was able to estimate a bulk modulus. These calculations are shown below.

$$\delta_B = \frac{F * L^3}{3 * E * I}$$

$$E = \frac{F * L^3}{3 * \delta_B * I}$$

$F$  = applied force on the snowboard

$L$  = Length from applied force to cantilever (17.5 inches)

$\delta_B$  = elastic deflection measured from applied force

$$I = \frac{1}{12} * b * h^3 \text{ (area moment of inertia)}$$

$$I = 4.103 * 10^{-2} in^4 \text{ (} b = 10.125 \text{ in } h = 0.365 \text{ in)}$$

Using data calculated from the various bending strain tests, an average bulk modulus of 982.87 ksi was found. Adding the bulk modulus to a stress equation ( $\sigma = E * \epsilon$ ), bending stresses were calculated for the various tests. Figure 28 shows the bending stresses for each test using the average strains recorded.

Test #	Force (lb)	Deflection (Inches)	Average Strain	Bulk Modulus (ksi)	Bending Stress (ksi)
1	7.5	0.4375	7.39	746.42	7266.68
2	17.5	0.75	31.26	1015.96	30727.06
3	32.5	1.25	80.51	1132.07	79129.98
8	10	0.5	9.86	870.82	9688.91
9	20	0.8125	35.73	1071.78	35116.64
10	35	1.4375	86.70	1060.13	85216.90

Figure 28: Chart of Deflection to Calculate Bending Stresses

When comparing torsional strains between conventional attachment and attachment through the rotating apparatus the differences in measured strain were negligible. When testing a 10 lb. weight, the difference in torsional strain between conventional and rotational binding was 2.21. This difference in torsional strain was due to the added height from the rotational apparatus, causing an increased torque on the board. When testing a 25 lb. weight, the difference in torsional strain between conventional and rotational was -0.17. The negative difference

indicates that the strain of the conventional attachment was greater than that of the rotational attachment. Based on these results, it was likely that some torsional strain was lost due to the deflection between the center bolt and nylon system.

Upon the completion of all data collection and processing, the group came to the conclusion that the addition of the rotating binding apparatus does not excessively increase or decrease the forces placed on a snowboard. By applying bending and torsional forces on a conventional snowboard binding and the designed prototype, data was successfully collected on the strain applied to the board at specific areas. This test proved that bending and torsional strain does not increase with the addition of the rotating apparatus.

## **Tensile Test**

### **Materials and Methods**

To better understand the allowable forces of the snowboard binding attachment mechanism, a tensile test was designed on the M6 screw inserts. The following materials and products were used to conduct this test:

1. .5 inch thick scrap nylon
2. M6 press-fit screw inserts
3. Instron machine
4. Circular base plate
5. M6 thumb screws (spade head screws)
6. Two vise grips

Testing the tensile strength between the M6 press-fit screw inserts and the top plate nylon was a crucial step in determining the binding apparatus's safety. A test was constructed using WPI's Instron machine located in Washburn Shops with the help of Professor Shivkumar. Since the group did not want to apply tensile forces to our design, scrap nylon was cut into four inch square to be used for tensile testing. Using the same process for assembling the top plate, 5/16 inch holes were drilled into the nylon, roughly eight millimeters deep. Screw inserts were press-

fit into the holes to simulate one of the four holes used for attaching a binding to the top plate. This process was done with three additional nylon squares to allow for multiple tests.



**Figure 29: Scrap Nylon used for Tensile Testing (left) and Thumb Screw (right)**

Due to capability limitations of the Instron machine's clamp, thumb screws with spade heads were purchased and flattened to fit into the clamp. These screws provided maximum surface area for the Instron clamps to fasten and pull from. Vice grips provided a strong hold between the nylon and circular disc plate while not getting in the way of the tensile testing. A complete illustration of our test setup is shown in Figure 30.



Figure 30: Tensile Test Setup

## Results and Conclusions

Using a crosshead speed of 0.00166 m/s, data was collected every 0.1 seconds from the Instron machine to measure the tensile forces acting between the nylon and screw inserts. From the three tests completed, maximum allowable force of the press-fit screw inserts and the nylon before tear-out was 207.6 N and average allowable force of 187.2 N. Based on these results, each binding apparatus would allow roughly 750 N of longitudinal force in tension. Complete test results illustrating force versus time can be seen in Appendix C.

The snowboard binding attachment design would allow for any normal forces applied to a board. Since most forces applied to the top plate of the board would not be acting entirely in the longitudinal axis, more testing would need to be designed to determine the safety of the apparatus. However, based on the strength of the nylon and results from tensile testing, the press-fit screw inserts would be able to withstand much greater torsional loads.



To improve the overall strength of the snowboard binding apparatus, a heating and cooling technique could be used. Screw inserts could be press-fit onto the top plate with a much smaller hole by submerging the nylon into hot water while cooling the screw inserts. The nylon will absorb the hot water at its liquid absorption rate of 0.8% of its total weight, causing the hole to increase in diameter. After the screw insert is press-fit into the hole, the nylon will mold around the screw insert as the water is cooled and evaporated from the nylon, giving the connection a much tighter tolerance.

## **Mountain Test**

### **Materials and Methods**

While lab testing is extremely beneficial to the overall understand of the apparatus, the group felt that mountain testing was necessary to truly understand its capabilities. In order to accomplish this, the team reached out to Jeff Crowley, President of Wachusett Mountain Ski Area, requesting the opportunity to conduct our testing. After a quick response, Jeff was more than willing to provide us with a place to test at no cost to the MQP budget. The following materials were required to perform the mountain test:

1. One snowboard set up with the rotating apparatus
2. Two additional snowboards for the other group members
3. Assorted sizes channel limiting inserts
4. Miscellaneous hand tools
5. One GoPro video camera with suction cup mount

The team arrived at the mountain at approximately 8:30 a.m. on January 23rd. Riding conditions were optimal with a temperature of 21°F and 3 mph winds. Upon leaving the mountain at 12:30pm, the temperature had risen to 25° F; all other weather conditions were consistent throughout the day.

The first step was to check in with ski patrol. Before starting any testing on the mountain, the project was described in detail to verify that our product would be safe not only to the team, but to other mountain users. It was made clear that the three group members would be the only riders testing the project and our test would be confined to two novice slopes. Upon the approval of ski patrol, we were able to begin testing.

The snowboard system was assembled on the mountain. This included the rotating apparatus and bindings. The GoPro was then mounted to the front end of the snowboard and the first team member strapped into the binding so as to perform preliminary flat ground testing. The purpose of this flat ground test was to get a feeling as to how the apparatus would rotate and to gain an understanding of the maximum allowable rotation that could occur. The apparatus was then locked into the skating position. The team tested this skating feature by moving around on flat ground and up the moving carpet to the top of the novice slope. While on the carpet, levels of comfort, balance and maneuverability were noted by each team member.

Each group member was given the opportunity to make a run down the educational “bunny” slope. This gave each of us an opportunity to perform all basic maneuvers that are made during a traditional snowboarding ride. These maneuvers consisted of heel side turns, toe side turns, carving, and stopping. In addition to basic snowboarding moves, the capabilities of the rotating feature were tested. An emphasis was placed on trying to utilize rotation of the feet so as to maximize testing results.

Once each member of the team rode the bunny slope, the next step was to ride the apparatus down the larger novice hill. This hill required skilled turning, changes in slope, increases in speed and a greater number of riders to be conscious of an avoid. Additionally, this larger novice slope gave us the opportunity to test the product through all chair lift procedures

including skating, waiting in line, sitting on the lift and getting on and off the lift. All aspects of this more challenging run emulate a real world riding experience.

The final observations that were to be made at the end of the day are how the apparatus functioned as a unit and resisted the conditions. The accumulation of snow within the bearing encasement was to be noted along with any visible wear and tear that could affect the assembly's functionality.

## **Results and Conclusions**

### ***Skating Feature***

The skating feature notably enhanced the overall riding experience when using the rotating assembly. When using normal bindings, the rider must push themselves across flat land with their free foot while the other is fixed in a pigeon toed position, resulting in an uncomfortable and inefficient form\movement. With the use of skate locking pin, and the rider's front foot pointing forward, parallel with the snowboard, the apparatus allowed the rider to move themselves in a more natural efficient movement. It does not require the rider to pigeon toe the front foot, was notably less tiring and allows for faster movement on flat land, similar to that of a skateboard as shown in Figure 31. Another advantage of the skating position is that the snowboard remains perpendicular to the rider's body. This positioning of the boards allows the rider to have an overall narrower footprint, preventing the tail end of the board from protruding out to the side and causing injury to other riders due to collision Figure 32.



Figure 31: Standing in Chair Lift Line with Rotational Apparatus



Figure 32: Group Member Getting on Chair Lift with Rotational Apparatus

### *Chair Lift*

The skating position was also beneficial while riding the chair lift. There were no accidental collisions of snowboards while waiting in line, riding up the ski lift or getting on and off the lift. Having the board in the skating position while riding up the lift also added comfort to a usually uncomfortable experience. When using conventional bindings, the snowboard hangs

to the right or left of the rider's knee/ankle plane. The weight of this cantilevered system (using the ankle as the fixed location) puts unwanted stress on the ankle and knee as these forces act on the joints out of their normal plane of motion. However, when utilizing the locked skating position, the board's moment was under the seat of the rider. The forces acted on the knee a in a normal manner, similar to the forces experienced while performing a leg extension as shown in Figure 33. This skating feature also assisted in the unloading of the rider as well. This was a direct result the position of the board. Since the board did not stick out to the side of the rider, there were no accidental collisions with other riders while unloading from the lift. This minimized the potential of falling. It also allowed the rider to unload in a trajectory straight forward off the lift. Again, this minimized the potential of falling due to collisions with other riders.



**Figure 33: Riding on Chair Lift with Rotational Apparatus**

### ***Riding with Free Rotation***

The ability to rotate one's feet while riding the snowboard was far more intuitive than expected. It provided a smooth ride with toe to heel transitions comparable, if not easier than a

conventional snowboard. It allowed the rider to have a greater level of control of the positioning of the board. The rotational aspect allowed the rider to maintain a more planar riding experience. During conventional “carving” a large amount of the rider’s weight is placed on the toe or the heel side of the board, causing the snowboard to lift on one side and dig deeper into the snow on the other side. With the rotating apparatus, turning requires much less of a weight transfer to the toe or heel side of the board. One simply has to change the orientation of their feet and the board points in the direction you wish to turn. For example, goofy riders would normally have to put most of their weight on the toes and dig that edge into the ground in order to make a left hand turn. However, with the rotating apparatus, those riders simply have to move their front feet in the direction of their toes and their back feet in the direction of their heels. This would in turn cause the front of the snowboard to point in a direction resulting in a left hand turn. The rider’s toes are now pointed in the desired direction of the turn. Additionally, the rider’s back is not facing the direction of motion (a conventional toe side maneuver puts the riders back facing down the slope), creating a more balanced approach to turning and avoiding “catching an edge”. At the same time, if the rider needed to change direction quickly, whether to dodge debris or a fallen person, the rider could simply transfer weight toe to heel as hard as need be (like a conventional binding) to avoid collision or rotate their feet to the point where the limiting pin hits the edge of the channel, causing the board to jerk in the desired direction.

Another unknown going into this test was whether or not the stopping or starting process was going to be hindered as a result of this product. The group concluded that stopping was not impacted by the addition of the rotating apparatus. We felt that stopping was improved as one could turn the board perpendicular to the direction of motion much easier with the ability to rotate one’s feet. Strapping into the binding however, was impacted as a result of the addition of

the rotating capabilities. Trying to stand in and strap down the bindings was more difficult if the rider did not first lock the apparatus at one of the fixed angles. When the product was locked strapping into the board was just like any other binding. See appendix D for a frame by frame view of toe-side to heel-side turn and back.

### *Apparatus Components*

During the test runs, the group concluded that there were two minor flaws in the design of the prototype. The first pertained to the channel limiting inserts. In order to maintain simplicity in our original prototype, the inserts were cut from block erasers. We felt that this material was sturdy enough to limit the pin while simultaneously damping the system to prevent violent collisions with the sidewall of the channel. The erasers proved to be too soft. Unless one put all of their weight on the channel side of the binding, the pin would rotate right over the inserts. However, regardless of the inserts, the spring loaded limiting pin worked as planned and stayed within the confines of the pre-milled channel. In addition to the spring loaded rotational pin, the locking pin worked as planned when rotation was not favored. There were no issues of the pin releasing from its locked position or sliding out of the pre-milled hole.

The center bolt attachment mechanism in our prototype needs some enhancements. The nut holding the top plate to the bottom plate can rotate as the top plate rotated. This caused the center bolt to become loose as the run progressed. This center bolt rotation resulted in an increased gap between the top and bottom plate as shown in Figure 34. The increased gap could potentially cause the limiting pin to release from the channel in addition to allowing more snow into the bearing encasement. In order to remediate this issue we were required to tighten the connection after each ride. It was observed that if the nut was tightened with too much force, it would restrict the rotation of the apparatus. The best way to fix this issue in its entirety is to use

either lock washers or lock nuts as the top center bolt connection. These locking nuts consist of a nylon interior lining, causing them to not come loose due to vibrations or rotations. The frictional forces within the lock nut will exceed the frictional forces between the exterior washer and the lock nut. A second form of remediation could be the use of a cotter pin connection on the top plate through the center bolt. This would prevent the need to screw any form of nut on the top plate and in turn there would be nothing to come loose as the apparatus rotates. See section titled “Future Design Features” for additional explanation of possible designs.

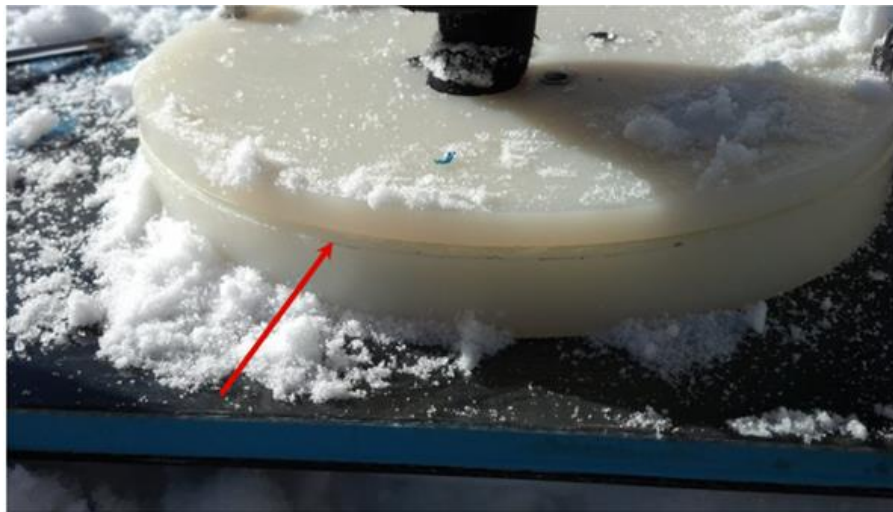

Figure 34: Gap between Plates

After all runs were complete, the top plate was removed to inspect the interior of the apparatus. The snow accumulation was much less significant than expected as shown in Figure 35. This amount of snow did not interrupt or prevent our apparatus from rotating as it should. Even with the frigid temperatures, ice did not build up inside our bearing system. The minimal amount of snow accumulation did not contain enough volume to become packed into the bearing system. The bearings were constantly moving, and in turn the snow did not have an opportunity to thoroughly freeze into ice and bind up the bearings.

Additionally, a minimal amount of snow accumulated within the limiting channel. This snow did not have any impact on the performance of the product or the degree of rotation the top



plate was restricted to. Like the bearing, the pin is constantly in motion, evacuating most of the snow buildup within the channel. The snow did not have the opportunity to turn to ice and in turn, the pin could cut right through any amount of accumulation.



**Figure 35: Snow Accumulation in Bearing Encasement**

The mountain test was vital to the understanding of this product. By experiencing real world riding conditions, the group was able to determine exactly how the rotating apparatus will perform. This test proved that the possibility of incorporating rotation into snowboarding is a feasible concept.

## **Future Design Features**

Upon the completion of designing, manufacturing and testing the prototype, the group recommends additional design features to enhance the riding experience presented by the rotating binding apparatus:

1. A damping system within the limiting channel
2. Exterior sealant – two possible designs
3. Modified center bolt system

Once a final angle of rotation is agreed upon by all members of the group, a damping system will be implemented within the channel to create a softer collision between the limiting

pin and the side wall. During initial testing of the completed apparatus with a 60° overall angle of rotation, we noticed that when rotating the full 30° to either side of the channel's center (rotation in the Y axis), the collision between the limiting pin and the sidewall was violent. The group came to the conclusion that over time, this could eventually lead to either the sidewall or limiting pin cracking if the forces become large enough. To resolve this issue, the group feels that rubber or EVA (Ethylene-vinyl acetate - the same closed cell foam material used in bindings) placed on the contact points at either end of the limiting channel would be durable yet soft enough to continuously dampen the contact of the pin and sidewall.

The design of the prototype required a small gap between the outer edges of the top and bottom plate in order to permit smooth rotation. However, this design feature makes the apparatus susceptible to snow/slush penetrating the exterior of the plates and entering the bearing housing. If accumulation within the casing becomes excessive, the snow/slush could hinder the rotation and make it difficult to transition smoothly to various angle orientations. When melted, the water will cause the bearing to rust within the housing. While the apparatus can be easily drained removing any of the eight screws bored through the top and bottom plate, the group understands that this will not be done after every run. In turn, snow/water will remain within the housing for extended periods of time. In order to prevent this, a rubber sealant or gasket could be placed on the exterior sidewall of the top plate extending down over the gap and bottom plate. Exact material and attachment methods would need to be further researched for designing this enhancement. However, the group believes this will provide sufficient protection from snow penetration. If, after testing this design the rubber sleeve does not act as an adequate sealant or is not durable enough to withstand harsh riding conditions, a second design option will be put into place. The team will design a top plate with an overall radius that is .25 inch larger than the

bottom plate. This additional material will allow for a channel to be machined into the top plate, therefore extending the additional .25 inches down over the bottom plate. This flange will act as a rigid sealant, snapping into a machined exterior channel on the bottom plate as shown in Figure 36. The image on the left is a crude representation of the overall look of the redesigned top plate. Note that there are no holes drilled into this plate as dimensioning of hole bores and screw connections would remain exactly the same as the current design. The right image depicts the general representation of how the top plate would connect to the bottom plate and act as a self-sealing device. The top plate is represented in green and the bottom plate in grey as shown in Figure 36.

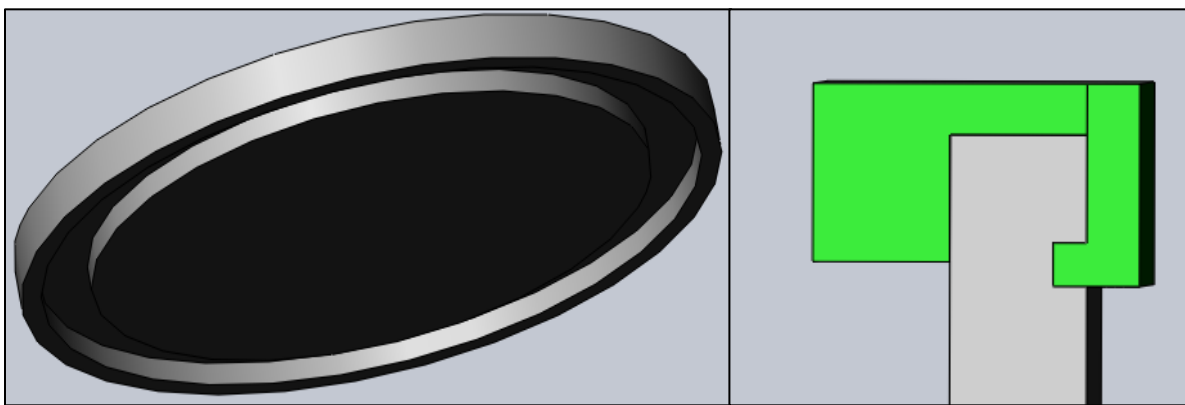

Figure 36: Potential Top Plate Design #2

A modified center bolt connection will need to be addressed in future designing. During the mountain testing of the rotational attachment, the center bolt connection came loose after runs down the mountain were completed. In order to fix this issue, a lock nut with a strong plastic thread may need to be used to prevent loosening. Another possibility would be to use a cotter pin mechanism to lock the nut and screw at a fixed location, thus preventing the top and bottom plates from separating.

## Conclusions

Based on initial design constraints, the group successfully designed and manufactured a snowboard binding attachment which provided the rider with an alternative riding experience from conventional snowboarding. This design successfully offered the rider rotational freedom limited to no more than  $160^{\circ}$  while providing comparable applied loads to that of a normal snowboard binding. This apparatus was compatible with any commercial snowboards and bindings with a 4-by-4 and 4-by-2 hole pattern. The design allowed for drainage of any water or snow accumulated inside the apparatus through the attachment holes located on the floor of the bottom plate. Dimensional specifications of a total height no more than 1.25 inches and overall diameter no more than 9.25 inches were met as well with this design. Upon the completion of this project, all design constraints were met, creating a successful alternative snowboard riding experience.

## References

- "Binding Reviews | The Good Ride." The Good Ride Binding Reviews. N.p., 2013. Web. 16 Sept. 2013. <<http://thegoodride.com/binding-reviews/?mens=1>>.
- Cobden, Ron. "Aluminium: Physical Properties, Characteristics and Alloys". European Aluminium Association. 1994. Web. 11 Nov. 2013. <<http://www.alueurope.eutalat/lectures/1501.pdf>>.
- "EVA Foam." Intecfoams. Intecfoams, 2010. Web. 15 Sept. 2013. <[http://www.intecfoams.co.uk/foams/eva\\_foam.html](http://www.intecfoams.co.uk/foams/eva_foam.html)>.
- Fletcher, Joe. "What Are Snowboard Bindings Made Of? | EHow." EHow. Demand Media, 24 Dec. 2008. Web. 15 Sept. 2013. <[http://www.ehow.com/about\\_4691811\\_what-snowboard-bindings-made.html](http://www.ehow.com/about_4691811_what-snowboard-bindings-made.html)>.
- Ides "High Density Polyethelene" UL. 2014. Web. 27 Sept. 2013. <<http://www.ides.com/pm/HDPE.asp>>
- Newton, David. "X Turn – Rotating Snowboard Binding." *X Turn – Rotating Snowboard Binding by David Newton » Yanko Design*. Yanko Design, 25 Jan. 2007. Web. 15 Sept. 2013. <<http://www.yankodesign.com/2007/01/25/x-turn-rotating-snowboard-binding-by-david-newton/>>.
- "Product | Quick Stance 360°." Product | Quick Stance 360°. Van Bregmann Industries Inc., 6 Dec. 2012. Web. 16 Oct. 2013. <<https://www.quickstance.com/product>>.
- Professional Plastics. 2014. Web. 14 Nov. 2013. <<http://www.professionalplastics.com/>>
- "Rotating Snowboard Bindings." Quirky. Quirky Incorporated, 15 July 2013. Web. 16 Oct. 2013. <<http://www.quirky.com/products/468-Rotating-Snowboard-Bindings>>.
- "Snowboard Bindings - Function and Types of Snowboarding Bindings." Snowboard Bindings - Function and Types of Snowboarding Bindings. MaxLifestyle International Inc., 2003. Web. 16 Oct. 2013. <<http://www.abc-of-snowboarding.com/whatarebindings.asp>>.

"Snowboarding Statistics." Statistic Brain RSS. Statistic Brain, 20 June 2012. Web. 15 Sept. 2013.

<http://www.statisticbrain.com/snowboarding-statistics/>.

"Swivler Swiveler Pivoting Rotatable Snowboard Bindings Rotate!" Swivler Rotating Snowboard Bindings. Jump USA, 29 Apr. 2009. Web. 15 Sept. 2013.

[http://www.jumpusa.com/swivler\\_rotating\\_snowboard\\_bindings.html](http://www.jumpusa.com/swivler_rotating_snowboard_bindings.html).

Via, Kate Rice. "Snowboarding Grows in Popularity." ABC News. ABC News Network, n.d. Web. 15 Sept. 2013. <http://abcnews.go.com/GMA/story?id=126308>.

"What Are Snowboards Made Of?" How To Guides Reviews and Articles for TheHousecom. N.p., 2013. Web. 16 Sept. 2013. <http://www.the-house.com/portal/what-are-snowboards-made-of/>.

Wood, T.D. "Screen Name Required." Snowboard Bindings: How to Choose. N.p., 9 Aug. 2013. Web. 15 Sept. 2013. <http://www.rei.com/learn/expert-advice/snowboard-bindings.html>.

## Appendices

### Appendix A: Machining Process of Bottom Plate

The cutting began with a pocketing operation of the bottom plate where the bearing and washers sit. For this operation a ½ inch end mill was used cutting into the stock 0.25 inches down to the height of the star structure. Once the tool reached the outer walls of the bottom plate, an additional 0.25 inches of stock was cut from the plate thickness, leaving only the star feature in the center of the plate. A finish was added to the sidewalls of the bottom plate and start pattern using a ¼ inch end mill to smooth the surfaces. A second pocketing operation was after this to create a limiting channel on the top walls of the bottom plate using a 1/8 inch end mill. To chamfer the walls of the walls of the star pattern in the center of the design, a 3/8 inch drill mill with a 45 degree cutting angle was used. Next, the center hole and 4 by 4 centimeter hole pattern were cut through the stock for the M6 snowboard screws. The diameter of the bottom plate was cut out using four separate but similar cuts. The first corner of the stock was cut out using a 3/8 inch end mill. By positioning the collet fixtures close to the corner edge of the stock, the tool was able to pass through the bottom plate without hitting the fixture. Once the tool made its pass through the corner of the nylon, the spindle was shut off to reconnect the fixture to the stock. This process was done for each of corner of the stock to minimize vibrations from the tool on the stock while keeping a fixture at each corner. Lastly the bottom plate was turned to the bottom and re-fixed into the machine. A pocketing feature was used to bore the center hole of the top plate using a ½ inch end mill. Figure 10 below illustrates the complete machining process breakdown of the bottom plate in ESPRIT.

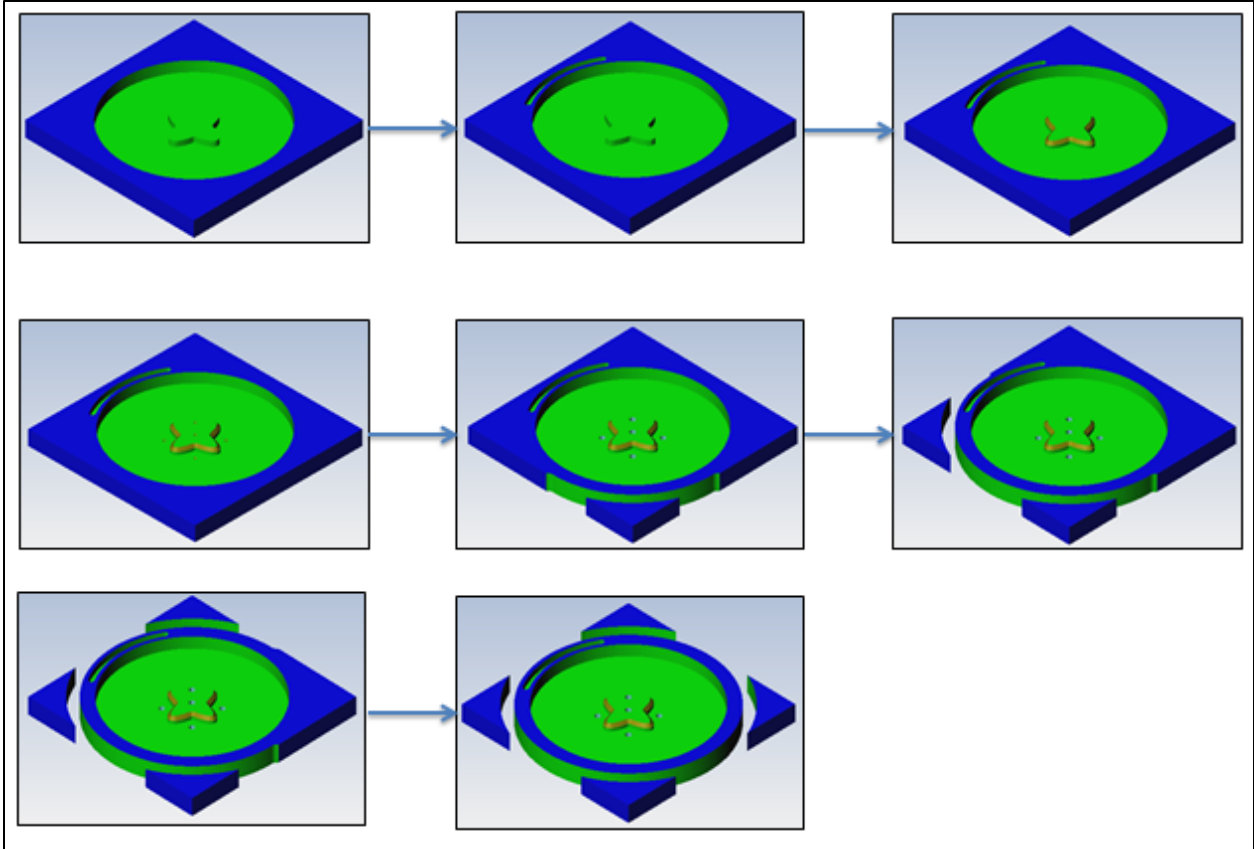

Figure 37: Machining Process Breakdown of Bottom Plate in ESPRIT



## Appendix B: Machining Process of Top Plate

The top plate was fixed into the CNC milling machine similar to the bottom plate to allow for cutting around the corners of the stock. Machining was done with the top plate facing down. A contouring operation was used with a ½ inch end mill to cut around the bottom of the top plate. Four passes were used to reach a diameter equivalent to the bearing. Once this was done, a pocketing feature was used to cut through the stock for an access hole to the bottom plate. A ¼ inch end mill was used around each pass to create a smoother surface. Next, the center hole and limiting pin hole were cut into the stock using a 0.238 inch end mill. The program concluded with by cutting each corner of the stock using a 3/8 inch end mill using the same process for the bottom plate. The top plate was then turned to the top and fixed into the CNC machine. The 4-by-4 centimeter hole pattern was cut 8 millimeters into the stock for the M6 screw inserts using a 5/16 inch drill. Lastly, a pocketing feature was used to bore the center hole of the top plate using a ½ inch end mill. Figure 11 below illustrates the complete machining process breakdown of the top plate in ESPRIT.

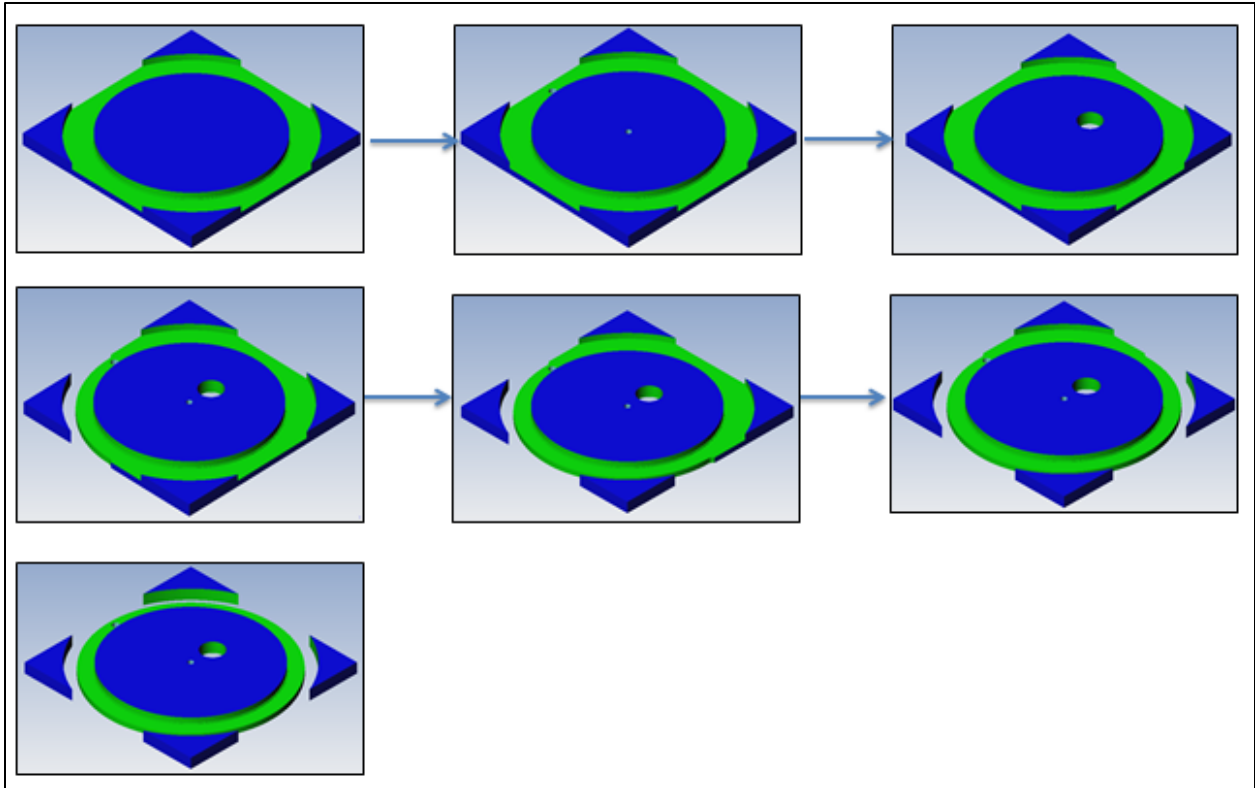
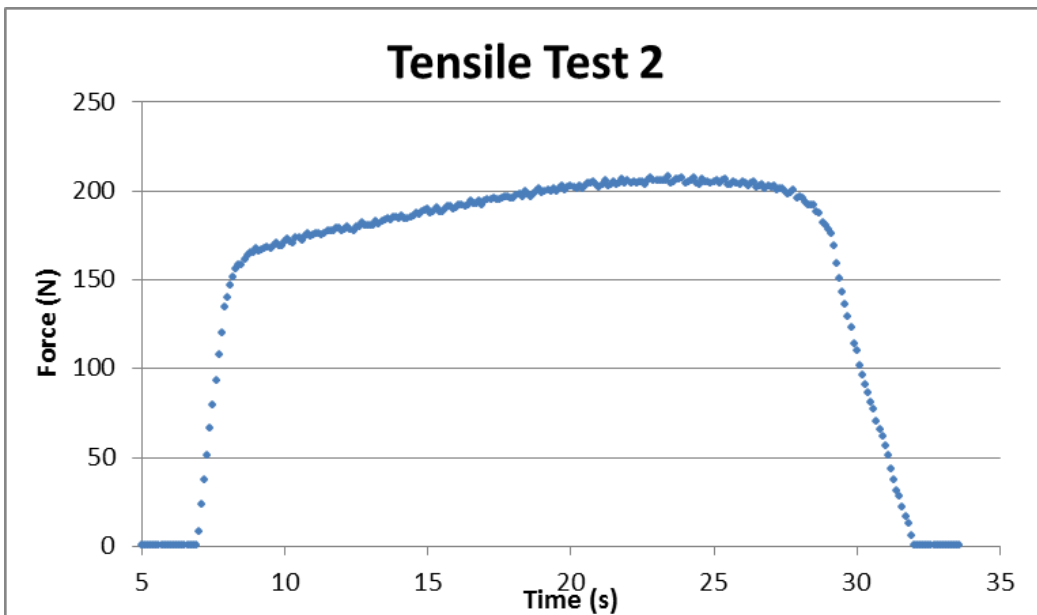
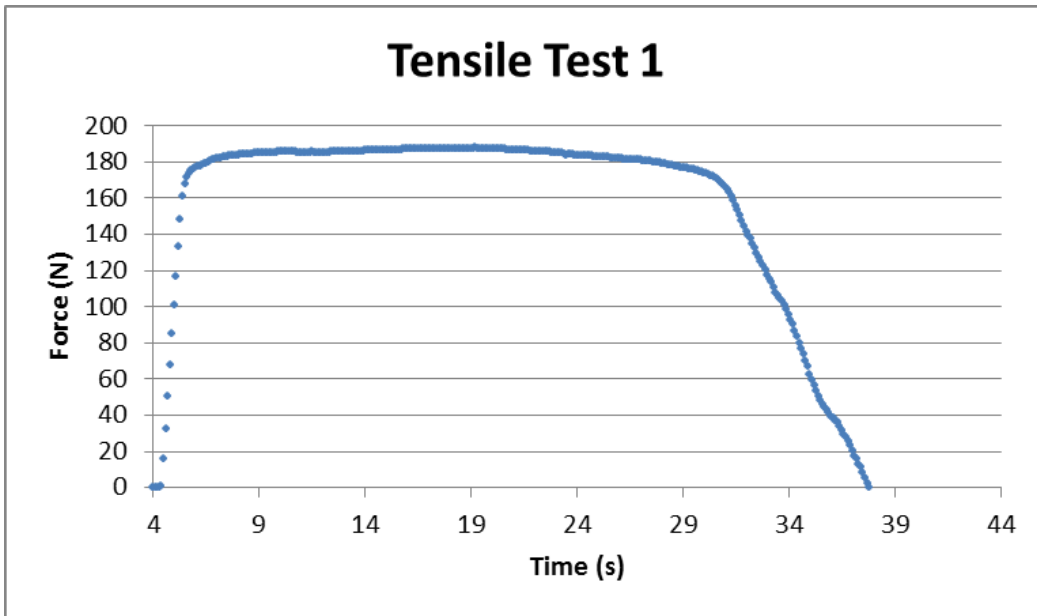
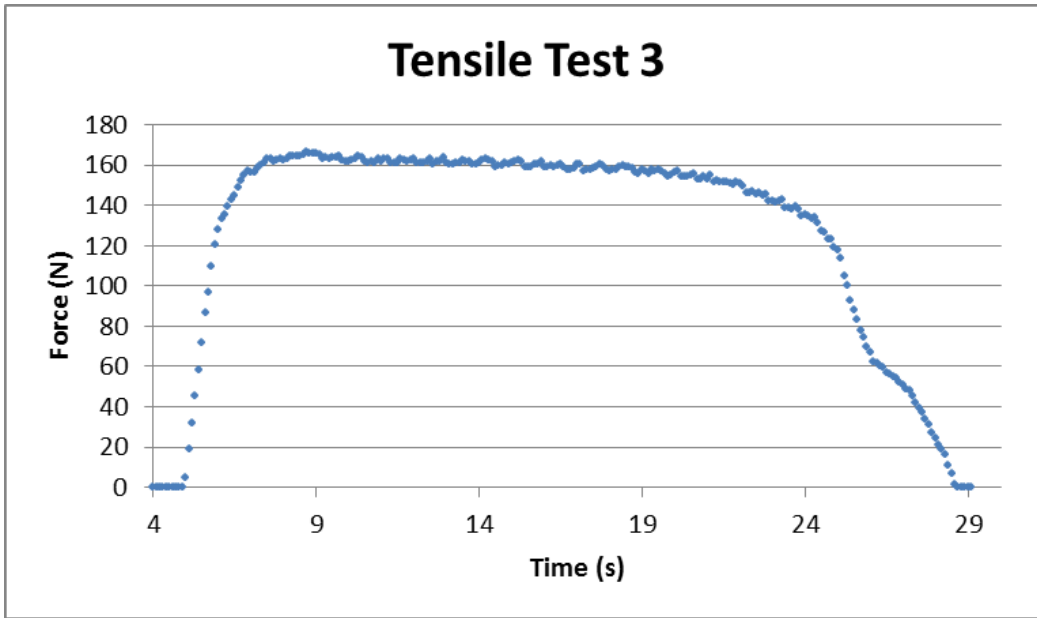

Figure 38: Machining Process Breakdown of Top Plate in ESPRIT

## Appendix C: Tensile Test Results

Graphs created from three tensile tests on Instron machine plotting force (in Newtons) over time (in seconds). Data collection were taken every 0.1 seconds with a crosshead speed of 0.00166 m/s (speed at which Instron clamp moves in the longitudinal direction to create tension).





Appendix D: Frame-by-Frame view of Toe to Heel Side Turn

















# Appendix E: CAD Drawings

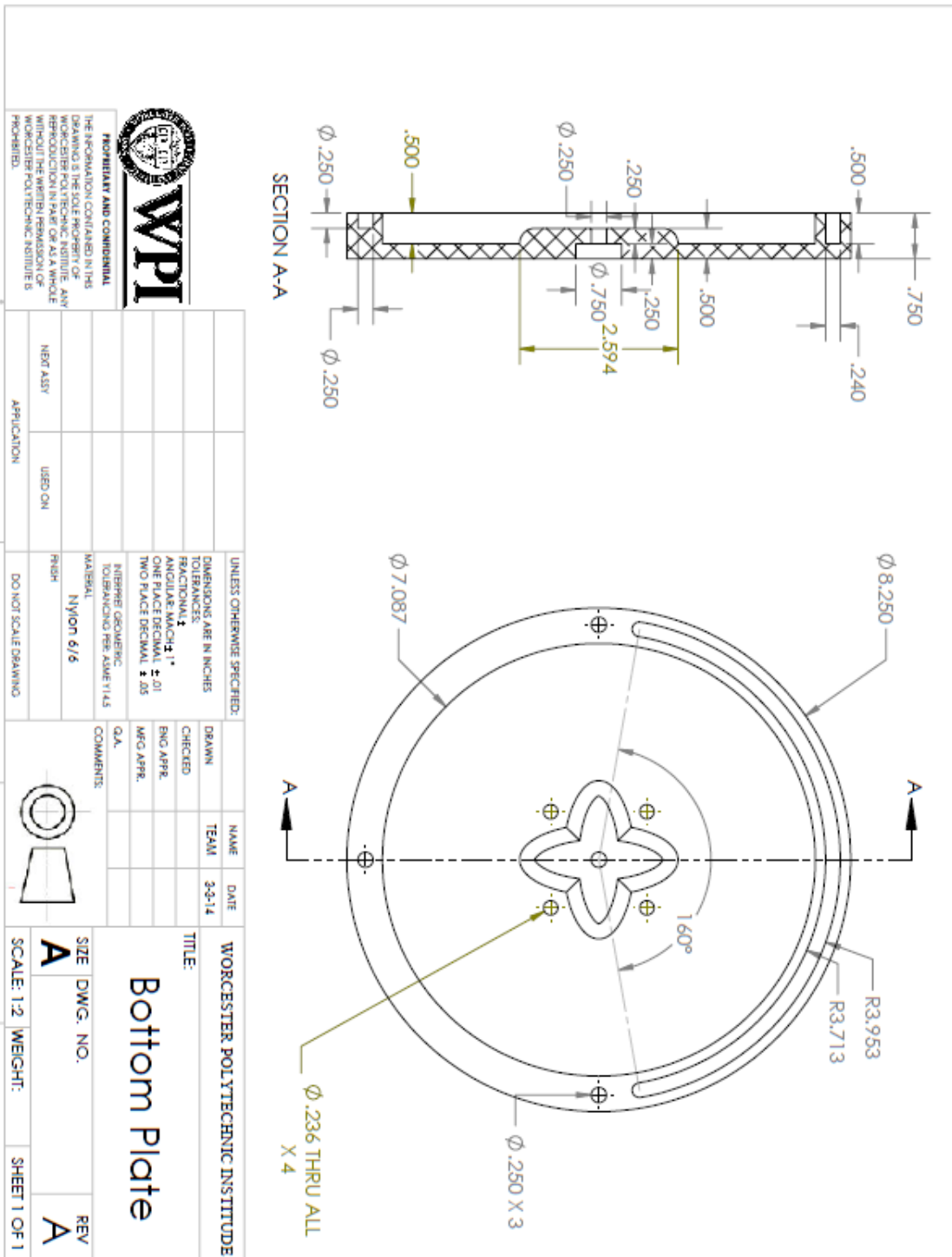

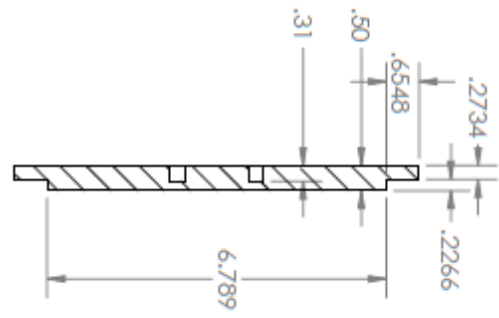

SECTION A-A  
SCALE 1 : 3

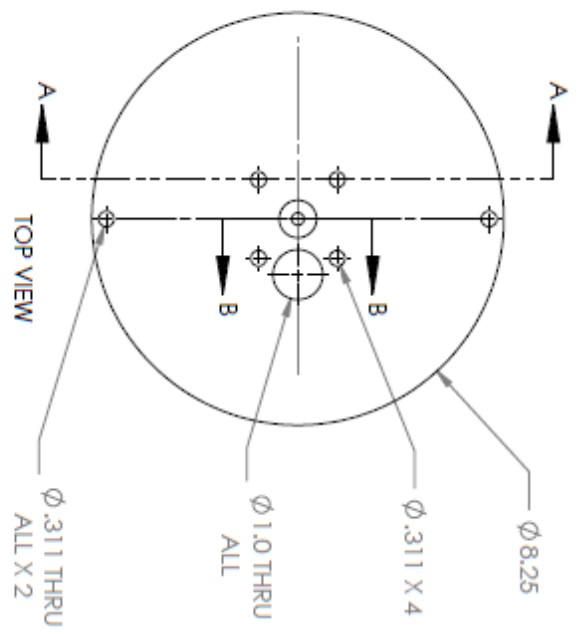

TOP VIEW

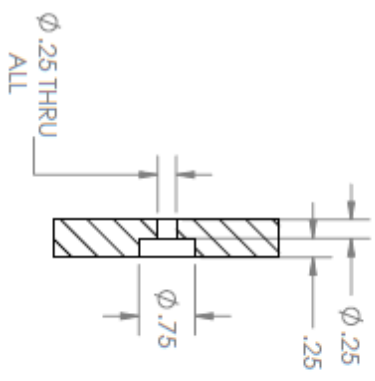

SECTION B-B  
SCALE 1 : 2

UNLESS OTHERWISE SPECIFIED:		NAME	DATE	TITLE:	SIZE	DWG. NO.	REV
DIMENSIONS ARE IN INCHES	TOLERANCES:	DRAWN	TEAM				
FRACTIONAL ±	ANGULAR MATCH 1°	CHECKED		Worcester Polytechnic Institute	A		A
ONE PLACE DECIMAL ±.01	TWO PLACE DECIMAL ±.05	ENG APPR.					
INTERPRET GEOMETRIC TOLERANCING PER: ASME Y14.5		COMMENTS:					
MATERIAL: NYLON 6/6							
FINISH: FISH							
DO NOT SCALE DRAWING							
APPLICATION: USED ON							
NEXT ASSY:							

5 4 3 2 1

**PROPRIETARY AND CONFIDENTIAL**  
 THE INFORMATION CONTAINED IN THIS DRAWING IS THE SOLE PROPERTY OF WORCESTER POLYTECHNIC INSTITUTE. ANY REPRODUCTION IN PART OR AS A WHOLE WITHOUT THE WRITTEN PERMISSION OF WORCESTER POLYTECHNIC INSTITUTE IS PROHIBITED.



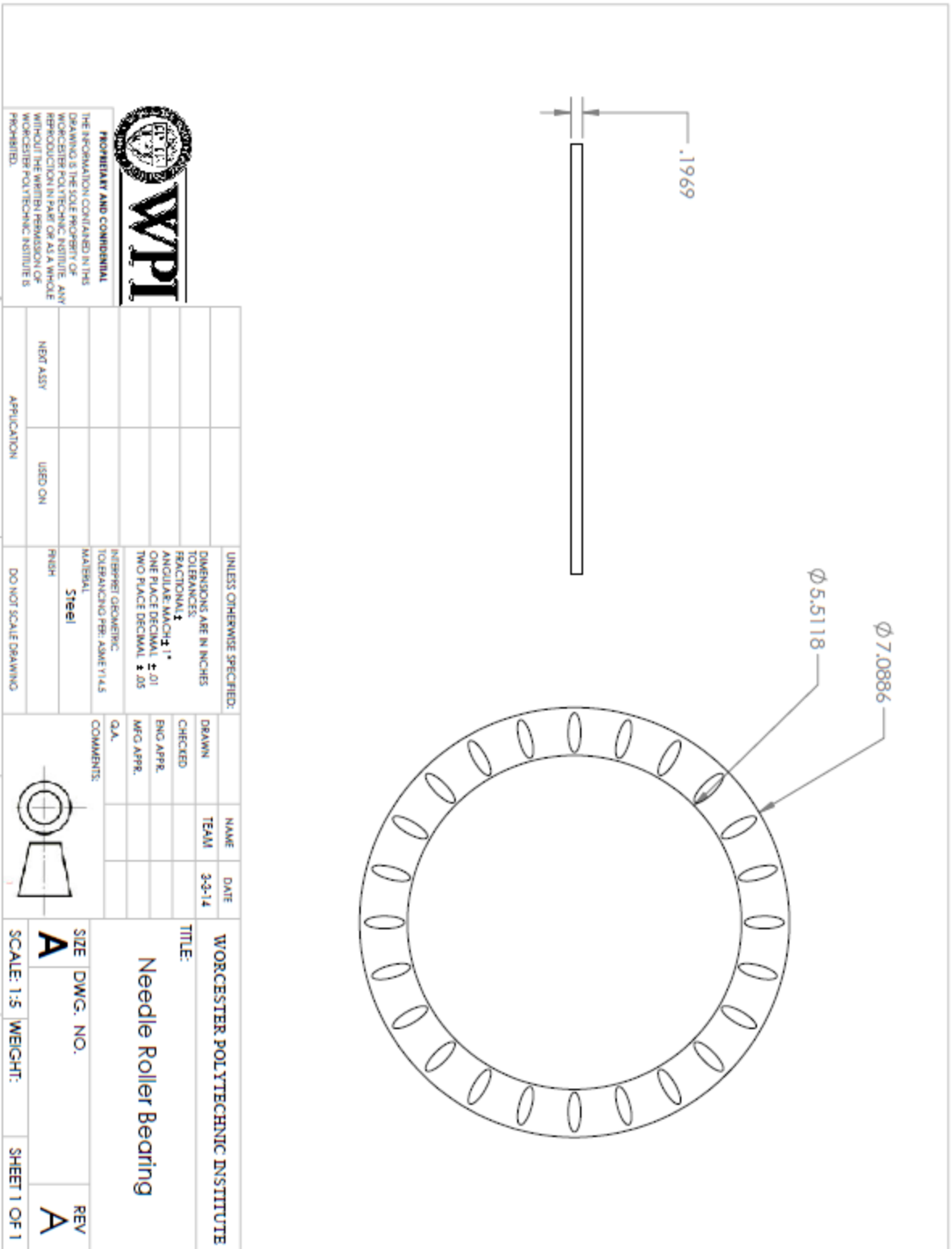



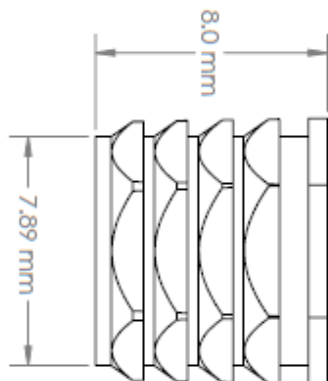

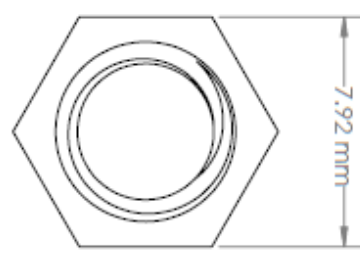

5
4
3
2
1

**PROPRIETARY AND CONFIDENTIAL**



THE INFORMATION CONTAINED IN THIS DRAWING IS THE SOLE PROPERTY OF WORCESTER POLYTECHNIC INSTITUTE. ANY REPRODUCTION IN PART OR AS A WHOLE WITHOUT THE WRITTEN PERMISSION OF WORCESTER POLYTECHNIC INSTITUTE IS PROHIBITED.

UNLESS OTHERWISE SPECIFIED:		NAME	DATE	<b>WORCESTER POLYTECHNIC INSTITUTE</b> TITLE: <h2 style="margin: 0;">Screw Insert</h2>
DIMENSIONS ARE IN MILLIMETERS		DRAWN	2-3-14	
TOLERANCES:		CHECKED		
FRACTIONAL ±		ENG APPR.		
ANGULAR MATCH 1/2 30°		MFG APPR.		
ONE PLACE DECIMAL ± 0.5		Q.A.		
TWO PLACE DECIMAL ± 0.15		COMMENTS:		
INTERPRET GEOMETRIC TOLERANCING PER:				
MATERIAL:				
<b>18-8 Stainless Steel</b>				
FINISH	USED ON			
NEPT ASSY				
APPLICATION	DO NOT SCALE DRAWING			

SIZE **A**

SCALE: 5:1

DWG. NO.

WEIGHT:

REV **A**

SHEET 1 OF 1



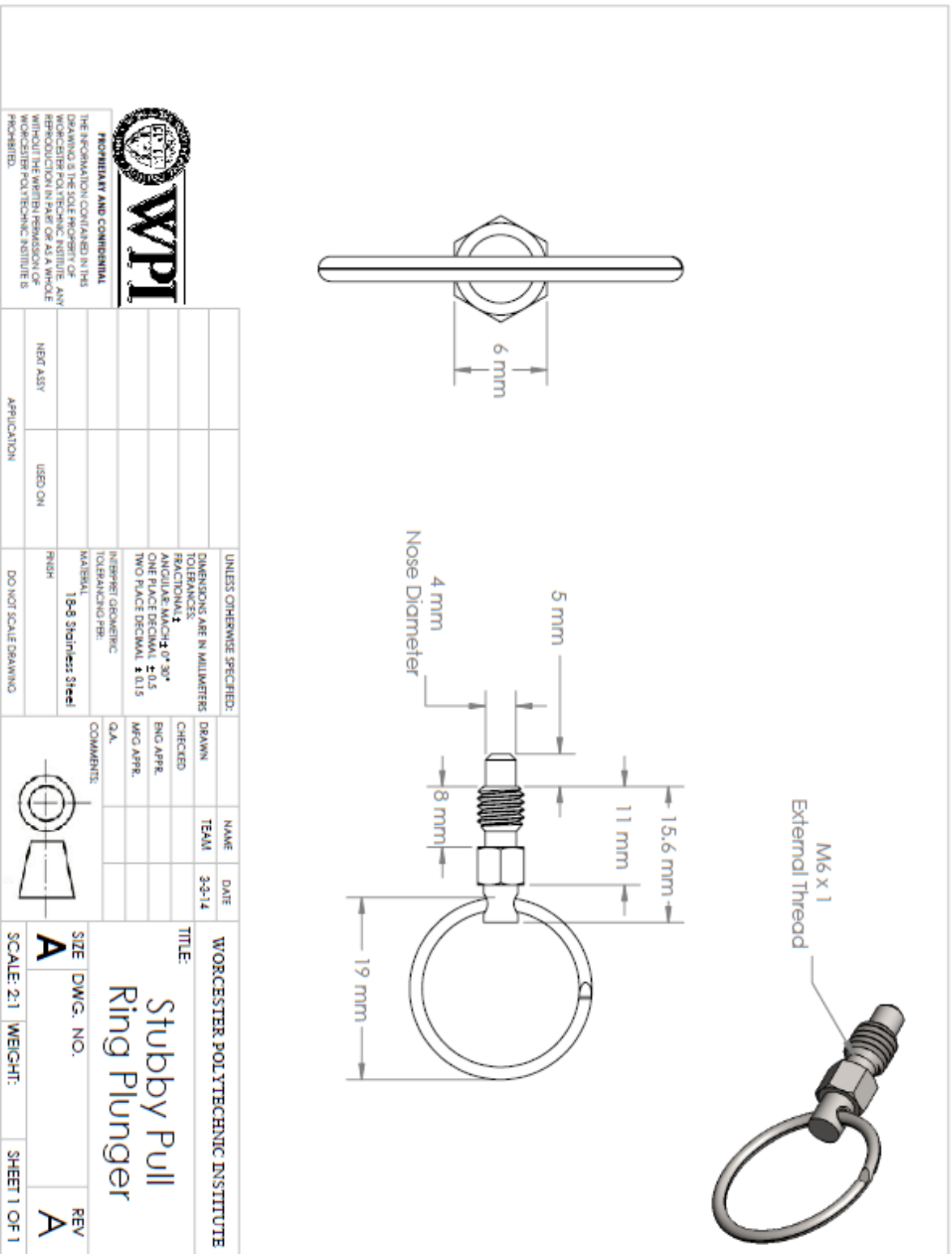

PROPRIETARY AND CONFIDENTIAL  
 THE INFORMATION CONTAINED IN THIS DRAWING IS THE SOLE PROPERTY OF WORCESTER POLYTECHNIC INSTITUTE. ANY REPRODUCTION IN PART OR AS A WHOLE WITHOUT THE WRITTEN PERMISSION OF WORCESTER POLYTECHNIC INSTITUTE IS PROHIBITED.



UNLESS OTHERWISE SPECIFIED: DIMENSIONS ARE IN MILLIMETERS		NAME	DATE	TITLE: <b>Stubby Pull Ring Plunger</b>	
TOLERANCES: FRACTIONAL ±	ANGULAR MATCH 0°-30°	DRAWN	3-9-14	WORCESTER POLYTECHNIC INSTITUTE	
ONE PLACE DECIMAL ± 0.5	TWO PLACE DECIMAL ± 0.15	CHECKED		SIZE	DWG. NO.
		ENG. APPR.		<b>A</b>	
		MFG. APPR.		SCALE: 2:1	WEIGHT:
		Q.A.		SHEET 1	OF 1
INTERPRET GEOMETRIC TOLERANCING PER:		COMMENTS:			
MATERIAL: <b>18-8 Stainless Steel</b>					
FINISH					
DO NOT SCALE DRAWING					
USED ON					
NEXT ASSY					
APPLICATION					

5

4

3

2

1



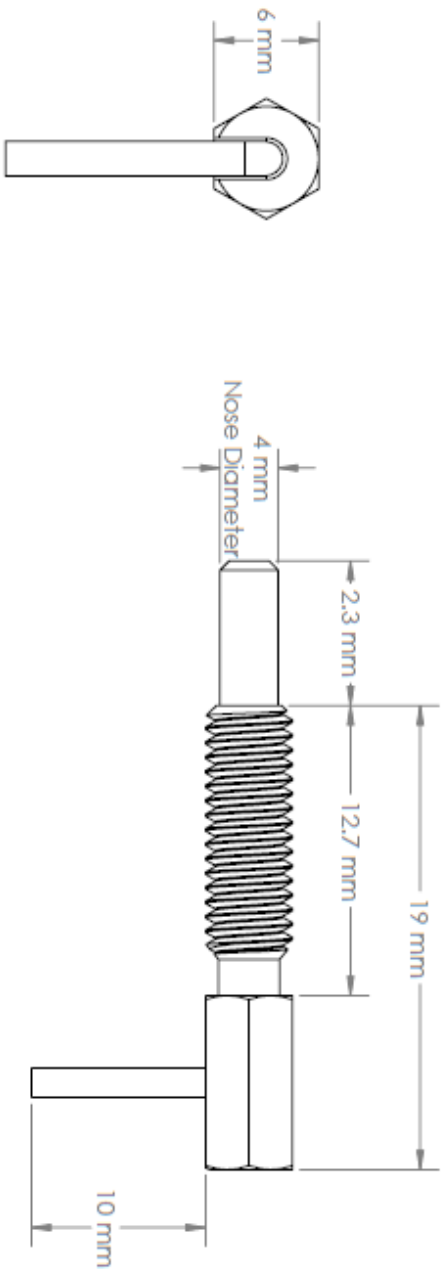

 <b>WPI</b>		PROPRIETARY AND CONFIDENTIAL THE INFORMATION CONTAINED IN THIS DRAWING IS THE SOLE PROPERTY OF WORCESTER POLYTECHNIC INSTITUTE. ANY REPRODUCTION IN PART OR AS A WHOLE WITHOUT THE WRITTEN PERMISSION OF WORCESTER POLYTECHNIC INSTITUTE IS PROHIBITED.	
		5	4
UNLESS OTHERWISE SPECIFIED: DIMENSIONS ARE IN MILLIMETERS TOLERANCES: FRACTIONAL: ± 0.30 ANGULAR: MACH: 0° 30' ONE PLACE DECIMAL: ± 0.15 TWO PLACE DECIMAL: ± 0.15 INTERPRET GEOMETRIC TOLERANCING PER:		DRAWN: _____ CHECKED: _____ ENG APPR: _____ MFG APPR: _____ Q.A. _____ COMMENTS:	NAME: _____ TEAM: _____ DATE: 3-2-14
MATERIAL: 19-8 Stainless Steel FINISH:		DO NOT SCALE DRAWING	WORCESTER POLYTECHNIC INSTITUTE TITLE: <b>Stubby Steel Level Plunger</b>
NEXT ASSY: _____ USED ON: _____		APPLICATION: _____	SIZE DWG. NO. <b>A</b> SCALE: 1:1 WEIGHT: _____ SHEET 1 OF 1 REV <b>A</b>

