

Measuring light speed

Objective

Use simple devices that could be found in daily life to measure the speed of light.

Science Fact

Light is wave, which will interfere each other to make the light “stronger” at some point. The term “interfere” basically means waves are combined to form a new wave which has different form. At the position where the wave is “stronger”, we say that we have a constructive interference.

Also, we know wave has frequency and wavelength, whose product gives the traveling speed of the wave.

In this experiment, we are using the fact that light carries energy; thereby microwave oven is chosen to show the effect of transmitted energy as heat, since it applies an apparent appearance change on the object inside in a short time. Due to interference, some spot in microwave oven will have “stronger” light thus change the object inside more significantly. The distance in between two significant change spots could be used to calculate the wavelength of microwave, and therefore calculating the speed of light.

Materials

- Microwave oven 2500MHz,
- A container with diameter larger than 6 cm, or paper plate.
- Raw eggs or chocolate with size larger than 12 cm × 12 cm.

Procedure

- 1) Put the chocolate on a paper plate or take out the egg-white and pour it into the container.
- 2) Put the paper plate or container in the microwave oven.
- 3) Turn on microwave oven and heat it up for 1 minute. (Hint: the time depends on

the microwave you are using, some required a little more time but some required a little less, you can try with some sample first to estimate the best time period)

- 4) Open the microwave oven, check for any significant changes. If there is no significant change, heat up more as needed. (Hint: DO NOT heat up for more than one minute, you can always heat up more but you cannot reverse it, and there is always a chance of fire if you heat it up too much)
- 5) Observe the change of chocolate and egg-white, measuring the distance between two most significant spots.
- 6) Calculate the wavelength, which is two times the measured distance. Then, get the frequency reading from the back of microwave oven, generally 2500 MHz .Calculate the speed of light by multiplying frequency with wavelength.

Observation and Analysis

- What changes have you seen from the chocolate and egg-white? Does it meet your expectation?
- Try the experiment for several more times with different samples, compare your result with the expected value: $c = 3.8 \times 10^8 \text{ m/s}$. Is your result correct?
- Calculate the error by the equation, $e = \frac{c-v}{c}$, where v is the calculated speed of light, record your result in the table below.

SAMPLE	DISTANCE	WAVELENGTH	ERROR

- If there is any large error, where do you think it comes from? Is there any way to avoid it or make the result more precise?
- Compare two different foods used in this experiment, is the time used to get a significant change the same? What would you think determine the time needed for heat up or cook different food?

Figure for what the result may look like

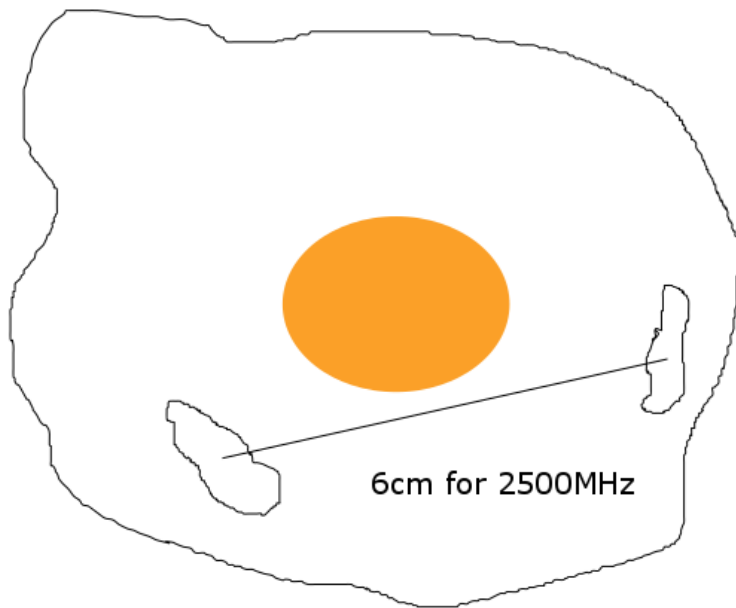
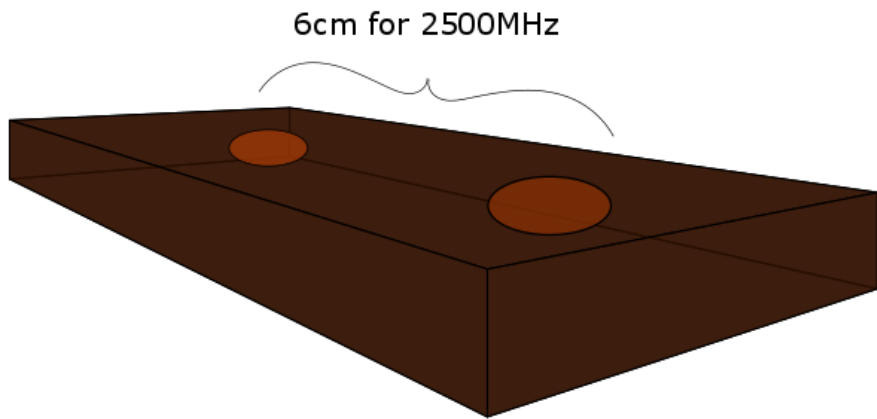

Measuring Diameter of hair

Objective

Use diffraction of light to measure the diameter of hair

Science Fact

Diffraction is the phenomenon that happens when light passes through small obstacle or around it. By definition, it means bending of light around the corner into the region of geometric shadow of the obstacle. Also, in physics, we describe it as the interference of infinite many waves, which result in a light-dark pattern called *fringes*. When you put a screen behind the small obstacle, you will not see a simple shadow area; instead, you will see the fringes.

In this experiment, you will use the fringe produced by diffraction to calculate the diameter of a hair, which is used as the obstacle for diffraction. You will simply shine a laser around a hair and observe fringes on the screen. Then, you can simply calculate the diameter of hair by the equation

$$d = \frac{m\lambda x}{y}$$

Where d is the diameter of hair; m is the number, or order of the dark fringe from the center of fringes; λ is the wavelength which will be given on the label of the laser pointer; x is the position from the hair to the screen; and, y is the distance from the first fringe to the center of fringes.

Materials

- Waxed paper or paper
- Laser pointer
- Hair, different types
- Ruler
- Tape

Procedure

- 1) Tape a piece of hair across the output aperture of the laser pointer.
- 2) Tape the laser pointer on the desk and point it toward the wall. Keep the distance between them more than 2 meters so that the fringes are separated enough to be measured.
- 3) Turn on the laser pointer, tape a piece of waxed paper or paper centered at the brightest position, or the center of the fringes. This serves as the screen.
- 4) Observe the fringes and mark the position of the dark fringes with a pencil or pen.
- 5) Turn off the laser, read the wavelength from the label of the laser pointer.
- 6) Measure the distance x from the laser pointer to the wall, and take down the paper from the wall. Then, Choose one dark fringe mark, measure the distance y to the center of fringes, record m , the number of that fringe, labeled using 1, 2, 3, ... , starting from the one nearest to the center of fringes.
- 7) Use the equation to calculate the diameter of the hair.

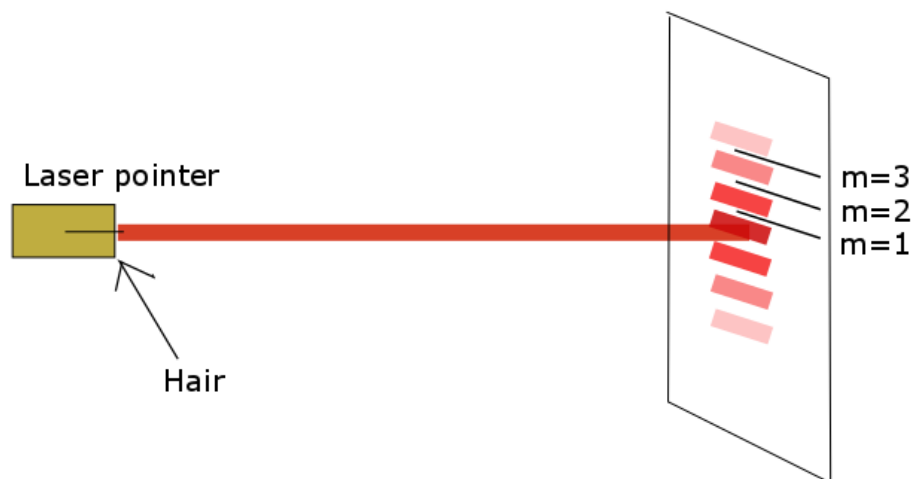

Observation and Analysis

- Is the fringe clear on the screen? Is the distance easy to be measured? Would it make big difference if the y reading is off by several millimeters?
- Compare your results with others and record them in the following table; make sure you have tried with different types of hair.

Type of Hair	m	y	x	λ	d

- Does different hair have different diameter? You can even try this with pet hair to see if there is any difference. Sometimes even hairs from same person have different diameter, which depends on the time they have used to grow and the condition of his scalp.
- Could you think of any practical use of this?

Stress in Transparent Materials

Objective

Observe the stress pattern in transparent materials

Science Fact

Think of a rope with two ends fixed. If you quickly move one end up and down, you will create a wave and it will propagate to the other end. This kind of wave is called transverse waves, and light, the electromagnetic wave is one of them. Like the waves on the rope vibrating in vertical direction, the electromagnetic waves vibrate in certain direction and we say that the light wave is polarized in this direction. As you will study later, the electric field and magnetic field are perpendicular to each other, and the electromagnetic waves vibrate in both directions. Therefore, when we talk about the polarization of light, we only refer to one direction which is the direction of electric field. Natural lights such as sunlight are polarized in all directions, called randomly polarized light. Randomly polarized light could be polarized by device called polarizing filter, the one we will use in this experiment.

You will put some transparent material in between two polarizing filter, and look through the polarizing filter to observe the stress pattern on the material. The alternation of molecular construction inside the material by stress will change the polarization of lights when they pass through. Therefore, it provides different image from the unchanged part and thus we can see the stress pattern.

Materials

- Light source such as lamp, torch
- Polarizing filters
- Transparent materials such as plastic film, plastic bottle, glasses

Procedure

- 1) Fix the position of light source and two polarizing filters in a line, look through

the two polarizing filter toward the light source to make sure the polarization axis of the two filters are perpendicular so that no light come through the two filters.

- 2) Put the material of your choice in between the two filters and look through the two filters toward the light source, record any observation.
- 3) Stretch or bend the materials in different ways and record anything you have observed through the two filters. You can draw the pattern on a piece of paper
- 4) Try with different materials, such as ruler, eyeglasses. Record your observations.

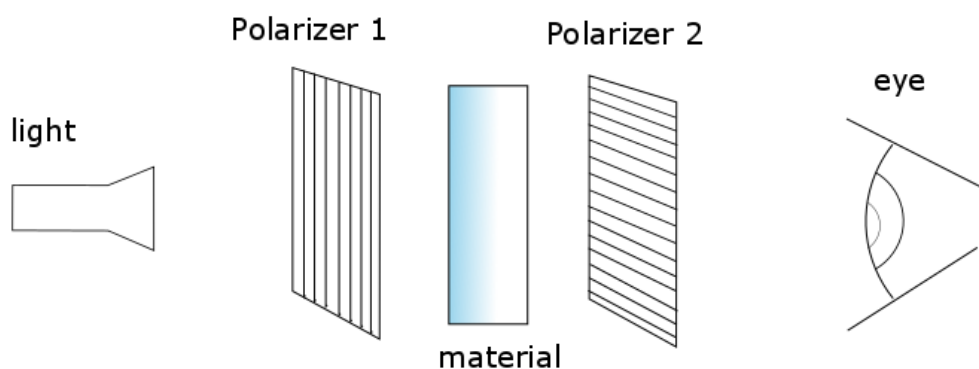

Observation and Analysis

- Record your result on a piece of paper, with the pattern you observed and the name of the material. Is there any difference between the non-stretched and stretched pattern? Does the pattern follow the way you stretch or bend the material as you expected?
- Why there is no light pass through two filters with perpendicular polarization? Why the light exist when stretched materials is in between?
- What could be a practical application of this?

Magic Box

Objective

Play with the box and understand polarization

Science Fact

In last experiment, we have talk about the polarization of the light. Light is electromagnetic wave and the polarization refers to the direction of the electric field that is perpendicular to the traveling direction.

In this experiment, we will continue to use polarizing filter, also called polarizer, to make magic box. By observing the special phenomena created by this box, you should have better idea about polarization.

Materials

- Shoe box, or cardboards that could be used to make a shoe box
- Polarizer
- Knife
- Chopsticks or long stick, or anything thin and long

Procedure

- 1) Make a shoe box with the cardboards if you do not have one provided, you can get dimension of a shoe box on the internet.
- 2) Cut a 4" by 2" rectangular hole on the front and back side of the shoe box, make sure the two holes are aligned so that they are in the same position of the two equal rectangular surfaces.
- 3) Tape 2 square polarizers with sides larger than 2 inches together to make a rectangular polarizer. One of them should have its transmission axis in horizontal and the other in vertical. Make 2 of this and cover the two opening on the shoe box with these two rectangular polarizers, fix them with tape. Make sure you have the horizontal polarizer faces the horizontal polarizer of

the other, and similar for the vertical polarizer. You can check this by shining a light on one side, light should be able to pass through the polarizer on the other side.

- 4) Cut a narrow slit on the right or left side of the box, the vertical surfaces in between the two with polarizer attached.
- 5) Run a chopstick or a long stick through the slit from one end to the other; record what you have observed through the polarizer.

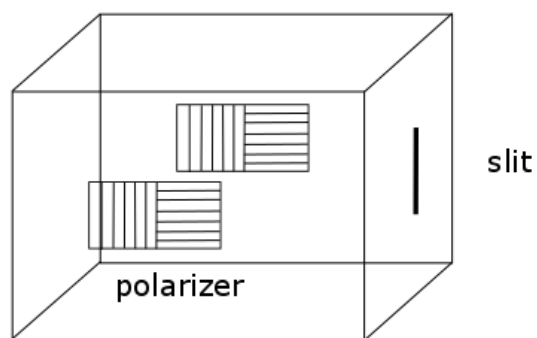

Observation and Analysis

- Did you see a wall through the polarizer? Where does it come from?
- Why do you need to use the polarizer?

Ultraviolet Filter

Objective

Find the filter for ultraviolet.

Science Fact

Sunlight is composed of electromagnetic waves of different wavelength. With previous experiments, we have seen that sunlight could be decomposed into lights of different colors. However, there exists some unseen light that could not be viewed by naked eye. The visible light includes colors from red to violet, with decreasing wavelength. For invisible light that has shorter wavelength than violet light, we call it ultraviolet.

You may have heard about ultraviolet in various ways, particularly, you may know it injures your skin cells and many skin care product advertise on their ability to protect you against ultraviolet.

In this experiment, we are going to test what material might block the ultraviolet using some interesting things called UV beads. Due to internal molecular construction, the beads change color under ultraviolet exposure. While there is no ultraviolet, it gradually returns to its original color. We are going to use this property to show what the existence of ultraviolet and find out the materials that can actually protect us from the ultraviolet.

Materials

- UV beads
- Spectroscope made from previous experiment
- Various transparent materials, such as glasses, plastic bottle, and plastic film. Or, thin objects such as paper that portions of light incident could pass through. If you wish, you can also test some sunscreen lotion.

Procedure

- 1) Take out some UV bead, provided that there is almost no ultraviolet in the building, the beads should stay in its original color, pure white.
- 2) Use the spectroscope made from last experiment, point the slit towards the sunlight, put the UV beads under any visible light that separated by the spectroscope, you should see now color change from the UV beads. This process must be conducted in the building; you can direct some sunlight into the building using some mirrors.
- 3) Take the UV beads outside the building, you will see suddenly color change, since ultraviolet is everywhere outside.
- 4) Cover the UV bead with the materials you chose, expose to the sunlight. You simply hold the beads with your hand and put the materials on your hand. If you want to test some sunscreen lotion, cover the whole bead with lotion and expose to the sun. Try different brands if you want to see which one is more effective. Record any color change.

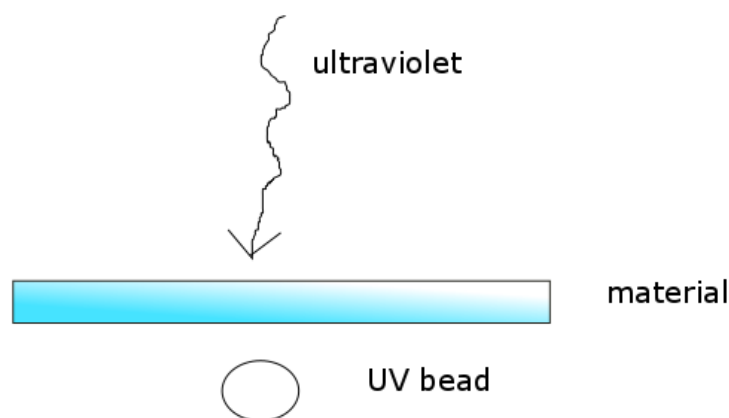

Observation and Analysis

- When you are in the building, there will be no ultraviolet, what would you think blocked it?
- Record your result in the table below:

Materials	Color change

- Compare your result with others, is there any disagreement? If yes, what could cause it?
- The ozone layer block most of ultraviolet radiated by sun on earth, make a guess about why it could block ultraviolet. Also, guess how sunscreen lotion works.

Spectrum

Objective

Exploring spectrum of different light sources

Science Fact

Recognizing colors is the one of the very elementary thing you have learned as a child. Isaac Newton has shown that the sunlight could be separated into colors of the rainbow by using prism, but each color could not be further separated. These colors are the fundamental colors of light, and it depends on the wavelength of the wave. However, the visible light that we can see is just a tiny part of all the electromagnetic spectrum, which refers to the collection of all possible radiation with continuously varied wavelength. Sunlight, or “white light”, in particular, contains the whole spectrum of the lights.

In this experiment, you will examine the spectrum of different light sources. To get a clear spectrum, you will make a device called spectroscope. Then, it will be used to separate lights from different sources.

Materials

- Cardboards
- Aluminum foil
- Knife
- Diffraction grating
- Paper
- Various light sources such as laser pointer, sunlight, and light bulb.

Procedure

- 1) Make a cylindrical tube with cardboard. The tube is used to block surrounding light, and you can choose any size you like. A tube of radius 2 to 4 cm is good to be held by one hand.

- 2) Cover one end of the tube with aluminum foil. You can fix the foil by rubber band or tape.
- 3) Cut a tiny slit with a sharp knife at the center of the foil.
- 4) Place the grating against the opposite end of the tube, and fix its position with tape. If the grating is not large enough to cover the tube, attach it to a piece of cardboard that is larger than the size of the tube, then place the cardboard against the tube, with the grating placed at the center of the circle.
- 5) Point the slit toward the light source and look through the grating. Some lights are not suggested to be viewed by naked eye. You can put a paper behind the grating and look at the light reflected from the paper. For example, you must use a paper if you use laser pointer as light source.
- 6) Record your observations.

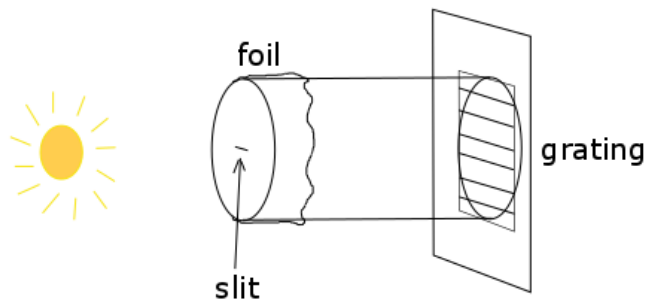

Observation and Analysis

- Record your light source and colors in the spectrum in the table below. Which color is the brightest?

Light Source	Spectrum

- Do all the light sources produce the same spectrum? If not, why are they different?
- Could you tell what colors are in a light by using your unaided eyes?
- Which light source has the most colorful spectrum? Could you make a guess why it could make waves of diverse wavelength?

Infrared Camera

Objective

Exploring heat flow with infrared camera

Science Fact

Similar to ultraviolet, we call the invisible light with wavelength longer than the red light infrared. However, we generally refer infrared to light that has wavelength less than 1 mm. For waves with longer wavelength, we call them microwaves or radio waves.

It was well-known that infrared is responsible for heat transfer. In this experiment, infrared camera is used to exploring the flow of heat. Bodies at different temperatures will radiate electromagnetic wave but with different “focus”; that is, light with certain wavelength are stronger than others. This emission is called black-body radiation. In theory, the hotter the object is, the more infrared it radiates. The infrared camera is specially designed to detect infrared just as regular camera detects visible light, and convert to images with different colors that represent different temperatures. Since the visible light is not captured by the camera, this camera works in completely dark place.

Materials

- Infrared camera
- Heat resources (anything)

Procedure

- 1) Turn on the infrared camera and view the object of your choice. You can look at the temperature distribution of your partner, or mix cold water with hot water and look at the heat flow in it, or anything of interest to you.

Observation and Analysis

- What did you use as an object? How it appears in the infrared camera? Record your objects with a description of the image you have seen in the camera, or maybe several drawing.
- Is there anything appears colder or hotter than you think? Did the temperature distribution surprise you? For example, have you thought about the coldest or hottest part of your body? Does the result meet your expectation?
- In nature, snake use infrared to detect its prey. In military, infrared camera is used to detect ambushed enemy. Could you think any other use of infrared?

Curve in the water

Objective

Make a light curve in water; try to make it as smooth as possible.

Science Fact

You may have realized in your daily life that the things in water actually located a little distance from the position that appears in the water. If you put a knife in a glass half-filled with water, you will see the knife “broken”. This effect is caused by refraction, which means light change path, or bend, at the interface of two media. Even if the light changed path, our eyes still view it as if it comes in straight line; therefore, the object is not located at where we see through water. Treat the interface as horizontal line, the angle between the incident wave line and the normal is the incident angle, and the angle between the transmitted wave line and the normal is the refraction angle. The two angles are related by

$$n_1 \sin \theta_1 = n_2 \sin \theta_2$$

Where θ_1 is the incident angle, and θ_2 is the refraction angle; n_1 and n_2 are the refraction coefficients of medium 1 and 2 respectively. In general, the refraction coefficient is related to the density of the medium. We can interpret the equation in this way: if the difference between the densities of the two media is larger, the light path will be bent more at the interface.

In this experiment, you will make layers of transparent liquid with in a density decreasing order. You should put the densest liquid at the bottom, the lightest liquid at the top, with each layer separated by thin plastic film. In order to show the light path, you can put several drops of milk into the liquid. The milk particles will scatter the light and make the light path visible; this effect is called Tyndall’s effect.

Materials

- Fish tank, best to be rectangular
- Containers, larger enough to store enough amount of liquid

- Water
- Ingredients to make the water denser, including salt, sugar, milk, dirt, gelatin, flour, and so on.
- Laser pointer
- Plastic film

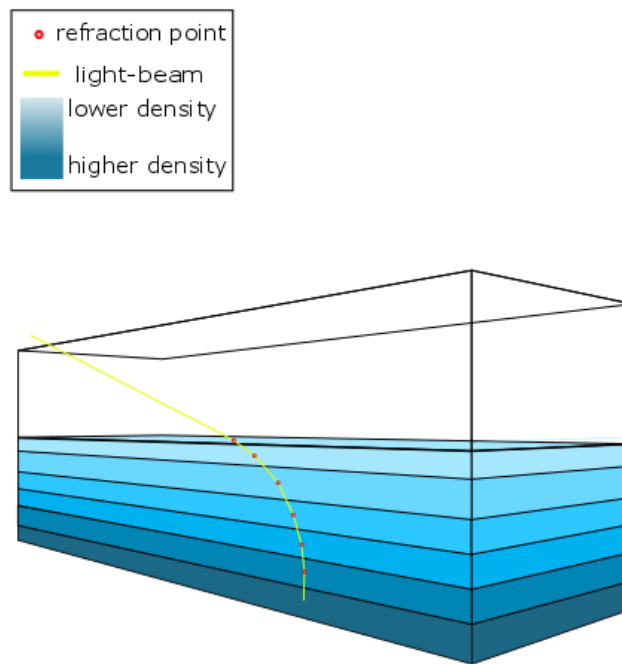

Procedure

- 1) Explore the refraction of different liquid that you have made. Shine the laser from air to the liquid at 60° from the normal; then, record the refraction angle for each liquid. Make sure you add several drops of milk to the all the liquid so you can see the light path. This could be done in different containers other than the fish tank.
- 2) Clean the fish tank; then, pour the liquids in a density decreasing order, and separate layers of the liquids by plastic films.
- 3) Shine laser at the surface of the lightest liquid, you will see a curve formed by several line fragments. To make this curve smoother, you will need more layers of liquids in a certain height.
- 4) Record your liquid composition and light path.

Observation and Analysis

- Record your liquid composition and refraction angle with fixed 60 degree incident angle.

Ingredients	Refraction Angle

- When you measure the refraction angle for each liquid, have you recognize any other feature? What may happen if we choose flour for Tyndall's effect and torch light for light source?
- What make the plastic film necessary? Does it affect the refraction?

Exploring Lens

Objective

Explore the relation between the image distance, object distance and focal length.

Science Fact

Lens will bend light path and form images depend on the distance from the object to the lens. For example, magnifier is a convex lens and we place the object close to it with distance less than the focal length to produce larger, upright image that help us view the details of the object.

In this experiment, you will explore the relation between the image and the positions of object and lens by moving the lens, object, and screen on the rail-track.

The expected relation is

$$\frac{1}{s} + \frac{1}{s'} = \frac{1}{f}$$

Where s is the object distance from the lens, s' is the image distance from the lens, and f is the focal length. This is called lens equation. The magnification, or ratio of image size to the object size, is given by

$$m = -\frac{s'}{s}$$

Materials

- Rail-track, holders
- Convex lens, concave lens
- Light source, such as candle, or cell phone.
- Paper

Procedure

- 1) Tape the paper to a piece of cardboard to make it easier to be held. This will be the screen.
- 2) Fix the light source, lens, and screen on the rail-track with holders, make sure they are movable and the lens is in between the light source and the screen.
- 3) Examine the relation by fixing the relative distance between the light source and

lens, and then move the screen to find a clear image. The reason for using candle or cell phone rather than laser pointer is that it has certain size so will can tell if the image is larger or smaller. The objects that do not emit light are not chosen since it is harder to make an image of them on a screen than light emitting object. To get better result, this experiment could be conducted in a dark room. In general, a room with all lights shut and window curtains drawn.is good enough for the experiment.

- 4) Try it again with different distance between the object and lens, at least one less than focal length, one greater than focal length, and one greater than two times the focal length. Also, you can try it with different lens
- 5) Record your observation and compare with the expected value.

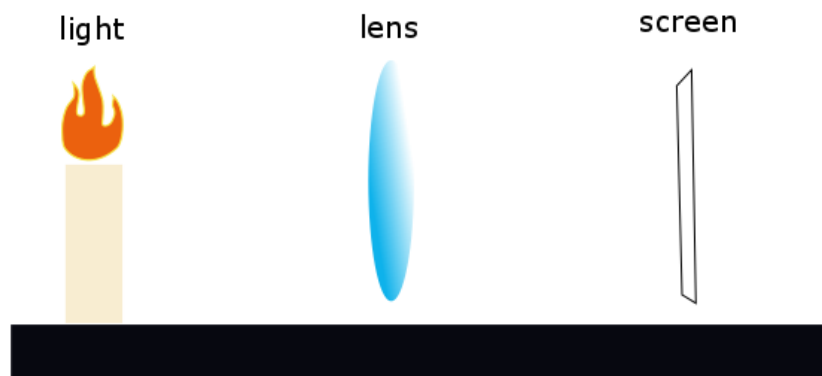

Observation and Analysis

- Record your result in the following table

Distance (s)	Type of Lens	Focal length (f)	Image Description (s' , m (\approx), +/-)

(For image, +/- denotes upright or upside-down image)

- Is there any difference between convex lens image and concave lens image with

same object distance s ?

- In the case of $s < f$, can you make a clear image on the screen? Why?
- Substitute the values from your result into the equations, are the equations valid?
If not, what would you think cause the difference? Are the equations simply wrong?
- With your observation, try to think about some usage of lens

Pinhole Image

Objective

Exploring the image formed by pinhole camera

Science Fact

A pinhole camera is basically a closed box with a pinhole centered on one end, and a screen attached opposite end.

As you have learned, rays of light come from the object will pass through the pinhole in a straight line, and strike a small area on the screen. Due to the small size of the pinhole, the rays come from the bottom of the object will not overlap those come from the top part, thus certain area on the screen is corresponding certain part of the object, a clear image will be formed. However, the image is upside-down as you can see in the figure below. The rays, object, and image form two similar triangles, thus we can always adjust the size of the image by moving the object.

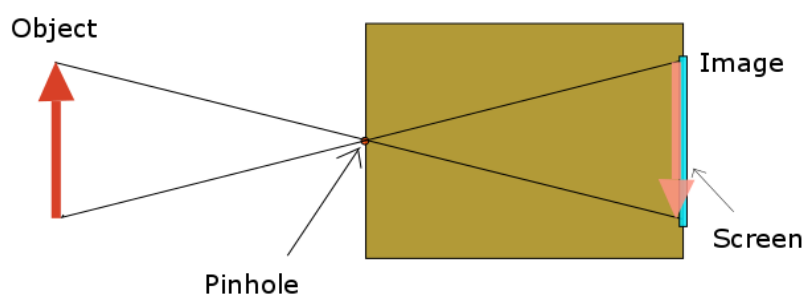

Materials

- Box of size you like, or cardboards
- Aluminum foil
- Needle, scissors or knife
- Waxed paper or frosted glass
- Tape

Procedure

- 1) Make a box with the size you like with cardboards, if not provided.

- 2) Cut a hole in the center of on one side of the box.
- 3) Stack 5 to 6 pieces of aluminum foil with size slightly larger than the hole you cut on the box. Pierce the stack with a needle. The inner foil pieces should have neat pinhole; tape one of them over the hole on the box. Keep the pinhole in the center.
- 4) Cut a larger rectangular on the opposite side, this hole could be large, $\frac{2}{3}$ of the box dimensions is a reasonable choice.
- 5) Attach a rectangular waxed paper or frosted glass slightly larger than the hole, tape it firmly over the hole, this will be your screen.
- 6) Aim the pinhole to certain object if you want to view its image one the screen, make sure the image is completely contained in the screen by using the property of similar triangle. Also, you can look at the view outside the window on the screen by pointing the pinhole toward your window.

Observation and Analysis

- What did you use for an object? Can you see the image on the screen? Is the image clear or blurry? Is it upright or upside-down? Write down anything you observed about the image.
- For viewing outside on the screen, is it better to stand in darker room or brighter room? Why?
- Is there any benefit for using pinhole image rather than naked eye? Can you think of an example?
- If the image is not clear enough, what could be the cause and how can you improve on it?

Convex lens camera

Objective

Build a convex lens camera and explore the image produced by it

Science Fact

This experiment utilized the results from the lens on rail-track experiment, in which we confirm the lens equation. You will make a camera similar to the pinhole camera, but in this case the pinhole is replaced by convex lens.

The physics idea is the same, but you can get a sense of how camera work in this experiment and by actually building you will have something to play with that is more convenient than lens fixed on the track.

Materials

- Cardboards
- Ruler, pencils,
- Scissors, knife, glue and tape
- Convex lens (9.5cm as an example)
- Frosted glass or waxed paper

Procedure

- 1) Get a cardboard, cut a rectangular piece of dimension 20 cm by 18 cm.
- 2) Draw a line parallel to each side, with a distance of 5 cm, separate the rectangle into 9 parts.
- 3) Cut off the 4 squares at the corners, then, make a rectangular opening in the middle rectangle.
- 4) This opening will be your viewing window; you can determine its size but no more than 8 cm by 6 cm. Fold along the line you drew to make a box, tape the sides together.
- 5) Take another cardboard, with dimension 19.8cm by 17.8cm (the difference

depends on the thickness of the cardboard), follow the same steps but this time, instead of a rectangular opening, a circle with size slightly larger than the convex lens is cut.

- 6) Take a piece of cardboard; make a tube with radius slightly smaller than the circle so that it could barely pass through it. Make sure the length is longer than 5 cm, and mark the 5 cm position from one end. Cut the remaining part several times to make a flower shape, fold all those petals outward.
- 7) Pass the tube through the circular opening, tape or glue the petals inside the box.
- 8) Cover the rectangular with a piece of frosted glass or waxed paper, tape it firmly.
- 9) Put the smaller box inside the larger one, and glue them firmly.
- 10) Make another tube with radius equals to the radius of the convex lens. Place the convex lens against one end of the tube and tape or glue it firmly.
- 11) Now, insert the other end into the tube connected with the box, you will have your camera ready. You can move the outer tube to make a clear image on the screen.

Observation and Analysis

- Why would it be important for the tube connected with the box be more than 5 cm? Provided that the focal length is about 9.5 cm.
- Why you want to move the lens instead of keep it fixed like the pinhole?
- Is it possible to get a clear image for any object at any distance? Why?
- What kind of image will be on the screen?
- Your eyes have lens in it which changes thickness when you switch to view far sight from near sight, or vice versa. How does it work? Is it better to change thickness or the position of the convex lens?

In progress

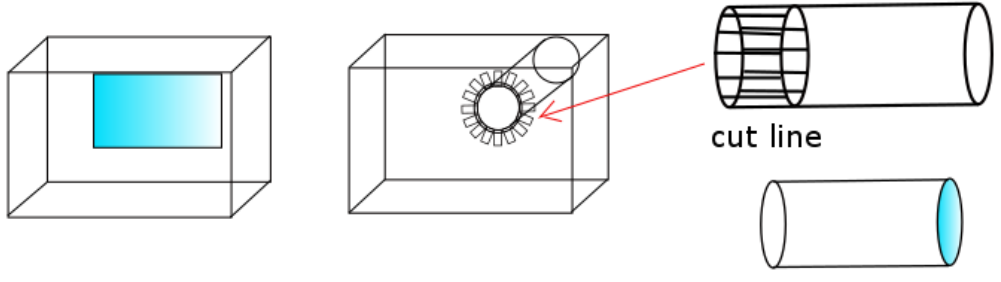

Finished

front

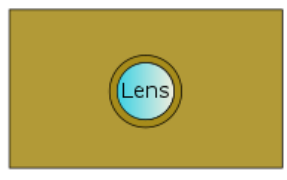

back



top

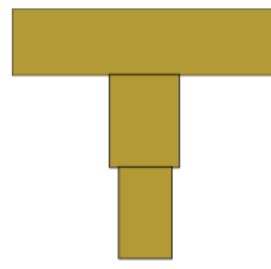

Microscope

Objective

Turn your cell phone into a microscope

Science Fact

The aim of microscope is to magnify the image of the object by more than 100 times so we can see some details of the object such as the cells of a piece of leaf. The microscope generally consists of two convex lenses. One is the objective and the other is the eyepiece. The purpose of the objective is to make a real image in between the lenses, while the other is used to create a virtual enlarged image of that real image. However, the image is inverted since the objective makes inverted real image. We eventually will see an inverted enlarged virtual image of the object.

Materials and Procedure

This experiment follows exactly the website:

<http://www.instructables.com/id/10-Smartphone-to-digital-microscope-conversion/>

You could follow the video step by step to make the microscope with material listed.

Observation and Analysis

- Try your microscope with different samples, such as leaves, onions, piece of cloth, and so on.
- Take a picture for each of them.
- Could you calculate the final magnification of your microscope?
- Could you explain the usage of each part of this setup?

Telescope

Objective

Build a simple Galilean telescope

Science Fact

To build a telescope, our aim is to make an image of a faraway object near us so that it looks like that object is near us. The simplest telescope we can build is called the Galilean telescope, which consists of a convex lens and a concave lens.

In Galilean telescope, the convex lens is called the objective and the concave lens is called the eyepiece. The basic idea is this: since the object is far from the convex lens, it will produce an inverted real image in between the two lenses; this will appear as if the object is really at the image position. Then, the concave lens will invert the image make it looks like viewing a near object with naked eye.

The main difficulty in this experiment is the choice of lenses. We need the focal point of the two lenses coincide, which means the simplest choice is the ratio of lens diameter to focal length be the same for both lenses.

Materials

- Convex lenses and concave lenses
- Cardboard
- Scissors and tape

Procedure

- 1) Take one convex lens, calculate the ratio of diameter to focal length, and take a concave lens with the same ratio. Make sure that the convex lens is larger than the concave lens.
- 2) Make a cone with cardboard of bottom size equals to the size of the convex lens, height equals to the focal length of the convex lens. Cut the cone at the position where the distance to the vertex equals to height of the concave lens focal length.

- 3) Place the convex lens against the larger end and the concave lens against the smaller end, fix them with tape.
- 4) Look through the concave lens with the convex lens point toward the object of interest.

Observation and Analysis

- Does the telescope work as you expected? Try with different lenses combination to see which combination gives your best result.
- Also, try lenses with different diameter to focal length ratio; make sure the focal points coincide when you make the telescope. What would you see in the new telescope? Is there any new feature from the one with lenses of different diameter to focal length ratio? Why?
- Record your observation and draw a simple conclusion about the choice of lenses.

Combination of lenses (size and focal length)	Observation (especially the edge of the image)

- Can you think of a better way to hold the lenses, without actually put tapes on them?

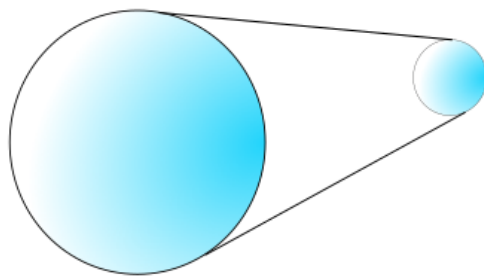
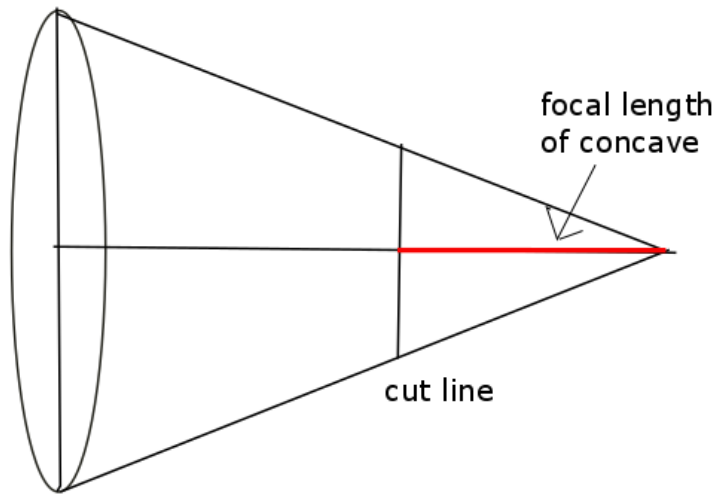
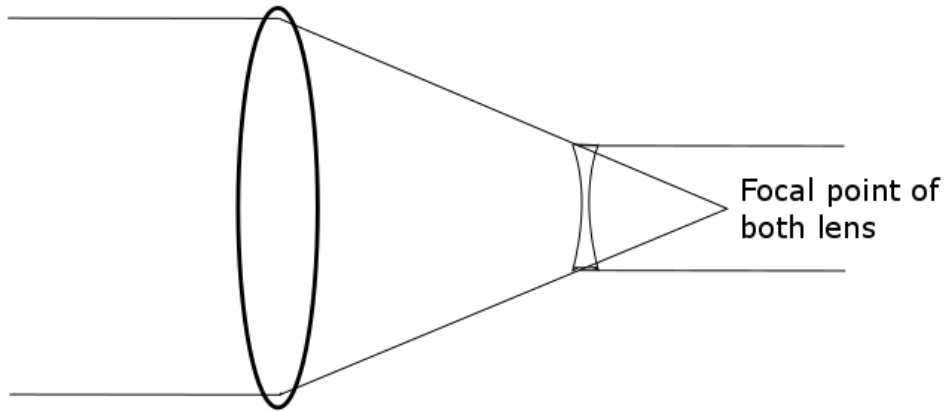

Resolution

Objective

Understand resolution with simple experiment

Science Fact

We heard about resolution frequently in our daily life. Sometimes we talk about it when we consider the clarity of a video; sometimes we consider it since it determines the price of devices with screen. But what resolution really is?

We know that light diffract after passing through a small hole. When light pass through the pupil of our eyes, which is a small hole, it diffracts and makes a pattern like the target for shooting with a central bright spot call airy disk. The size of the airy disk depends on the size of the hole, the wavelength of the light, and the distance from the hole to the viewing screen. In our eye, when light comes from two small points of light pass through pupil, the light from each source produces its own diffraction disk. By the rule called *Rayleigh's Criterion*, if two airy disks have their center fall on the edge of the other, we can distinguish those two light sources. If they are closer than that, we will not be able to see the difference.

Screen has many small light spots called pixels. If the pixel per area is low, when we move close to the screen, we can actually see several spots with fundamental colors. We say the resolution is low if the spots are relative easy to be recognized. For high resolution screen, pixel per area is high; the airy disks caused by the light spots in our eye are too close to each other, so we cannot recognize them as different objects. Therefore, their collection appears to be a whole image in our eye. Nevertheless, if we keep enough distance from the screen, so that light spots for even low resolution can form airy disks close to each other enough that make us unable to distinguish each one of them. Then, we will a single picture with no "dots". The resolution of video means the same thing, pixels per area. However, for video with low resolution we generally will not see light spots but blurred images since we could not perform enough details with the number of pixels provided, but the light spot only

depends on the screen

In this experiment, you will observe lines of dots to get an idea about how *Rayleigh's Criterion* works

Materials

- Paper
- Colored pen
- Tape

Procedure

- 1) Draw two lines of equally spaced dots with different colors. Suggested colors are red and blue. Try to make the space in between two dots as small as you can.
- 2) Tape the paper on the wall, and then stay far enough so that they appear to be two solid lines.
- 3) Carefully observe the patterns and move slowly toward the wall, record the distance from wall when you can see separated red dots instead of solid lines. Do it again for blue dots.
- 4) Analyze your result. You can also try with other colors.

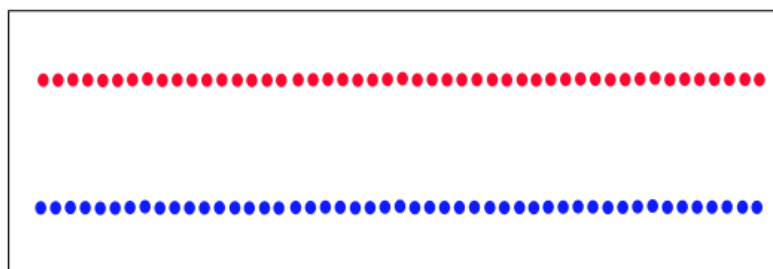

Observation and Analysis

- Which dots can you see first, red or blue? Why?
- Compare your result with other, then, make a conclusion about if the distance needed to resolve the dots depends on color.
- From your observation and understanding, can you give a definition for resolution of a screen? For example, what does 1920×1080p resolution mean?

What makes it different from a 1366×768p resolution to our eyes?

- Put 3 lines of dots closely to mimic the pixels of television, mix red, blue, and green dots in these lines. What would you see when you are far enough from it?

Try with different pattern of mixing those 3 colors.

References:

"\$10 Smartphone to Digital Microscope Conversion!" Instructables.com. Yoshinok, n.d. Web. 27 Apr. 2016.

2013, July. "Explorations in Optics." July 2013 EXPLORATIONS in OPTICS (n.d.): n. pag. July 2013. Web. 27 Apr. 2016. <<http://www.osa.org/osaorg/media/osa.media/Membership/Explorations-in-Optics-July-2103.pdf>>.