



# Energy Monitoring for Compliance with the Merton Rule



**By: Theresa Cheng**  
**Derice Orso**  
**Nathan Roy**  
**Jieyu Wu**

# **Energy Monitoring for Compliance with the Merton Rule**

City Knowledge, Energy Data Management, and the Merton Rule II

An Interactive Qualifying Project Report  
submitted to the Faculty of  
WORCESTER POLYTECHNIC INSTITUTE  
in partial fulfillment of the requirements for the  
Degree of Bachelor of Science

by

Theresa Cheng

Dericc Orso

Nathan Roy

Jieyu Wu

Date: April 23, 2008

Report submitted to:  
Professor Peter Hansen, Advisor  
Professor Stanley Selkow, Advisor

Adrian Hewitt, Project Liaison

## **Abstract**

Our team created a prototype system to monitor compliance with the “Merton Rule,” which mandates that buildings produce 10% of their energy from renewable energy sources. We developed and installed the prototype system at a new retail facility and retrieved energy information from a sensor connected to solar panels from a remote computer. We evaluated the use of the prototype system with other forms of renewable energy and analyzed the financial viability of the Merton Rule.

## **Executive Summary**

Climate change is a global issue, but local communities can have an impact on reducing the emissions of greenhouse gasses. The London Borough of Merton, in an effort to combat global warming, has initiated a program to limit their carbon production. Merton has established the Merton Rule, which requires that all new commercial buildings must derive at least ten percent of their total power from renewable resources.

To enforce this rule, the Merton Council needs to monitor the renewable and nonrenewable energy consumption of commercial buildings. Therefore, the Merton Council asked three teams from Worcester Polytechnic Institute to create a prototype monitoring system which would allow them to supervise a building's compliance with the Merton Rule. This project is the second in that series of three projects. The first project was responsible for the design of a system which would allow developers to enter projected energy data about their new constructions and grant the Merton government access to this data. In addition, the Merton government needs a way to constantly monitor the compliance by the building developers. To this end, the first team also created the framework for an energy monitoring system.

Our project focused on the physical implementation of this monitoring system and the overall viability of the system for future development and implementation throughout Merton and possibly all of London. This was completed by fulfilling three objectives. First, we developed a prototype system, for monitoring the physical energy

usage data from the buildings and transferring the data collected on site to a remote computer. The Merton government would have access to this remote computer to ensure that buildings are complying with the Merton Rule. Second, we explored the possibilities of expanding our system to monitor other renewable energy technologies that are viable in Merton. Finally, we presented the financial benefits of expanding the Merton Rule to all of London and raising the minimum renewable energy requirement to twenty percent.

The final team in the project sequence will consolidate and finalize the works of the previous two teams and propose the entire system for funding from the London government. This series of projects is designed to develop a system of overseeing compliance with the Merton Rule that will be reproducible in other regions of London. By providing thorough documentation and testing of the system during development, the final outcome of the sequence of projects will be to demonstrate to other local governments the methods and expected costs are feasible for monitoring the compliance with environmental policies.

### **Establishing the Working Prototype System**

The first objective of our project was to establish a working prototype system at The Big Yellow Self Storage Company. This system monitors the energy generated from the photovoltaic panels in The Big Yellow Self Storage Company and sends this data to a remote computer that could be accessed by the Merton government.

In order to create the system, we first chose a sensor to monitor the electricity from the photovoltaic (PV) panels. In selecting a sensor, we compiled a list of viable sensors that could monitor the photovoltaic panels. However, we discovered that The Big Yellow Self Storage Company already had a sensor that was installed with the PV panels and we decided to integrate our system with this sensor.

Next, we wrote sample applications for the Merton Rule Monitoring System (MRMS), which is the computer technology including the Onsite Server program and an application to request data from the Onsite Server. The first program, the Onsite Server, runs on a computer installed in the Merton Rule buildings. The server is responsible for collecting data from the sensors in the building and accepting requests from the Remote Requesting Application (RRA) for energy use data from the sensors it monitors. The second application, the RRA, was written to be able to request data from any sensor that the onsite server computer is monitoring and to connect to any computer that is running the Onsite Server program.

Lastly, a laptop running our Onsite Server application was integrated into The Big Yellow Self Storage Company to interact with the sensor. This entailed physically connecting the laptop to the sensor and a broadband connection to transfer the energy data to the Remote Requesting Application located offsite upon request. The install was completed after evaluating the electrical infrastructure at The Big Yellow Self Storage Company.

## **Developing Monitoring Methods for Alternative Renewable Energy Sources**

The second objective of the project was to complete research into alternative methods of renewable energy that do not generate electric current. The methods that are viable in Merton include ground source heating, solar thermal water heaters, and biomass boilers. These technologies were explored to establish the full potential our system.

After communicating with experts who are familiar with these technologies, we established the science behind these energy sources and why they are considered renewable energy. An Appendix was created on how to monitor a solar thermal water heater, and this science can be applied to ground source heat pumps as well. In addition, after speaking with members of the renewable energy monitoring industry, we were able to provide an appendix on the devices used to do this monitoring.

## **Evaluating the Financial Viability of the System**

The Mayor of London is extending the Merton Rule to all of London and expanding it with an increased minimum requirement; twenty percent of a building's total energy must be generated by renewable technologies (Greater London Authority, 2007). Our third objective addressed some of the financial implications of this rule. We examined the extended rule's effects on commercial and residential properties in London and the financial incentives of this rule for the local governments of London.

By requiring the commercial and residential buildings of London to supply twenty percent of their total energy consumption with renewable technologies, these buildings will save money in electricity bills. In order to determine these savings, first we calculated the total renewable energy generated in London. This total energy was then separated into either the commercial and domestic sector to calculate the monetary savings in energy per sector. Furthermore, to make our calculations more feasible, we assumed that electricity consumption remained the same as present day and that the renewable technologies used would only supply energy in the form of electricity. We estimated that London's commercial sector is expected to save £2,640,000 and the residential sector is expected to save £3,740,000 in energy costs annually.

Additionally, when the extended Merton Rule is adopted throughout London, there are benefits for the local London governments as well. One of these benefits is that the city of London would be saved from potential carbon emissions. We first estimated the total tons of carbon expected to be saved from using these renewable technologies. Again, we assumed that the electricity consumption of London remained the same as present day and that the renewable technologies used would only generate supplemental electricity. We attempted to put a monetary figure on this saved carbon by evaluating carbon according to the trade value, the social cost, and the shadow price of carbon. We computed that the annual carbon savings for London according to the



trading value, Stern's social cost, and Defra's shadow price of carbon are £372,103, £719,059, and £528,720 respectively.

An additional benefit for local London governments is that by outfitting London to accommodate the extended Merton Rule, there would be a large profit for the industry of renewable technologies. We estimated that £102,400,000 worth of renewable technologies would need to be purchased in London to supply the extended rule. This expansion to the industry of renewable technologies means more jobs for the citizens of London. Also, if the supply of these technologies can sustain the demand, there may potentially be lower costs for these renewable technologies.

The Merton Rule is a progressive environmental policy that has the promising potential to combat climate change. However, without enforcement the rule would be ineffective. The sequence of three projects from WPI students explores a solution to how the Merton Rule can be successfully monitored. The prototype system created at The Big Yellow Self Storage Company shows that a system is realistic. However, our system is not only specific to one building. The research into alternative renewable energy sources extends the scope of our project. Lastly, the financial study of our system illustrates the economic value of the Merton Rule. If our system receives the necessary funding from the London government, it can be further developed to monitor the Merton Rule and similar environmental policies successfully and efficiently.

## Table of Contents

1.0 Introduction .....	1
2.0 Background Chapter .....	6
2.1 Climate Change and Greenhouse Gasses .....	6
2.1.1 Valuing Carbon.....	7
2.2 Climate Change Policy in London, England.....	9
2.2.1 Background of Merton Rule.....	9
2.2.2 Viability and Implementation .....	11
2.2.3 Future Policy .....	12
2.3 Renewable Energy Sources.....	13
2.3.1 Solar Water Heater .....	13
2.3.2 Photovoltaic Power.....	14
2.3.3 Small Wind Turbines .....	15
2.3.4 Ground Source Heating.....	15
2.3.5 Biomass Heating.....	16
2.3.6 Combined Heat and Power Generators (CHPs).....	17
2.4 Information Systems.....	17
2.4.1 Sensors.....	18
2.4.2 Merton Hierarchical Online Monitoring and Energy Reporting .....	20
2.4.3 City Knowledge .....	20

2.4.4 Renewable Energy Localized Installation Entry Form.....	23
2.4.5 Geographical Information System (GIS) .....	23
2.4.6 Local Online Urban Information System (LOUIS).....	25
2.5 Summary .....	26
3.0 Methodology.....	28
3.1 Establishing a Working Prototype System .....	29
3.1.1 Sensor Selection.....	29
3.1.2 Writing Sample Applications.....	30
3.1.2.1 Onsite Server Program.....	31
3.1.2.2 The Remote Requesting Application .....	32
3.1.3 Integrate a Computer into The Big Yellow Self Storage Company .....	33
3.2 Monitoring Methods for Non-Electric Renewable Energy Sources.....	34
3.3 Evaluating the Financial Viability of the Merton Rule .....	36
3.3.1 Viability for Commercial Buildings and Residences.....	36
3.3.2 Viability for the London Government.....	37
3.4 Summary .....	40
4.0 Results and Analysis.....	41
4.1 Establishing a Working Prototype System .....	41
4.1.1 Sensor Selection.....	42
4.1.2 Writing Sample Applications.....	44
4.1.2.1 Onsite Server Program.....	45

4.1.2.2 The Remote Requesting Application .....	47
4.1.3 Integrate a Computer into The Big Yellow Self Storage Company .....	48
4.2 Monitoring Methods for Non-Electric Renewable Energy Sources.....	52
4.2.1 Solar Thermal Water Heaters .....	53
4.2.2 Ground Source Heat Pumps.....	55
4.2.3 Biomass Boilers .....	57
4.3 Evaluating the Financial Viability of the Merton Rule .....	57
4.3.1 Viability for Commercial Buildings and Residences.....	57
4.3.2 Viability for the London Government .....	60
4.4 Summary .....	64
5.0 Recommendations .....	66
5.1 Establishing Working Prototype system at The Big Yellow Self Storage Company ....	66
5.1.1 Sensor Selection.....	66
5.1.2 Write sample applications for the Merton Rule Monitoring System .....	67
5.1.3 Installing the Merton Rule Monitoring System in Buildings.....	70
5.2 Monitoring Methods for Non-Electric Renewable Energy Sources.....	71
5.3 Evaluating the Financial Viability of the Merton Rule .....	73
5.4 Guidelines for E Term Team.....	75
6.0 Conclusions .....	78
6.1 Establishing a Working Prototype System .....	79
6.2 Monitoring Methods for Non-Electric Renewable Energy Sources.....	80

6.3 Evaluating the Financial Viability of the Merton Rule .....	80
6.4 Summary .....	81
Appendix A: London Borough of Merton Overview .....	83
Appendix B: Renewable Energy System Setups.....	86
Appendix C: Recommended Non-Electric Monitoring Sensors .....	90
Appendix D: Recommended Electric Monitoring Sensors.....	93
Appendix E: Understanding Electricity at Commercial Grids .....	100
Appendix F: How to Install Power Sensors in a Single Phase System.....	104
Appendix G: How to Install Current sensors in a Single Phase System .....	108
Appendix H: Dealing with Three Phase Systems .....	116
Appendix I: Creating Power Sensors From Scratch .....	123
Appendix J: How to Manually Install the Merton Rule Monitoring System .....	127
Appendix K: Contents of MRMS CD .....	132
Appendix L: How to Install the Merton Rule Monitoring System.....	135
Appendix M: How to Use the Onsite Server Program .....	147
Appendix N: Onsite Security Devices.....	154
Appendix O: How to use the Remote Requesting Application.....	158
Appendix P: List of Contacts .....	167
Appendix Q: How to write plug-ins for the MRMS.....	169
Appendix R: Microcontrollers vs. USB .....	185
References .....	203

## Table of Figures

Figure 4-1: Proposed Install Diagram for Big Yellow Self Storage Company .....	50
Figure 4 -2: Final Big Yellow Self Storage Company Install Diagram .....	51
Figure 4-3: Solar Thermal Water Heater Monitors.....	54
Figure 4-4: Ground Source Heat Pumps .....	56
Figure 4-5: Calculation of Energy Saved from Renewable Sources .....	59
Figure 4-6: Annual Savings of Commercial and Domestic Sectors .....	60
Figure 4-7: Total Annual Carbon Savings .....	61
Figure 4-8: Calculation of Tons of CO2 Emitted.....	62
Figure 4-9: Renewable Technologies Industry Potential Profits.....	64
Figure A-1: Merton’s Location .....	83
Figure A-2: The Organization of Merton.....	85
Figure B-1: Solar Thermal Water Heater Monitoring .....	86
Figure E-1: Electrical System Diagram .....	100
Figure E-2: Voltage Source with Load .....	100
Figure E-3: Voltage Source with Loads .....	101
Figure E-4: Voltage Source Showing Current Flowing through the Loads.....	102
Figure E-5: Voltage Source Showing Current Flowing through the Loads.....	102
Figure F-1: Electrical System Diagram .....	105
Figure F-2: Electrical System Diagram with Power Sensors Installed.....	105
Figure F-3: Electrical Components in a Building .....	106

Figure G-1: Electrical System Diagram.....	109
Figure G-2: Electrical System Diagram and Installed Sensors.....	109
Figure G-3: Electrical Components of a Building .....	110
Figure G-4: Voltage of AC Waveform for Power Grids .....	113
Figure G-5: Absolute Value of Voltage of AC Waveform for Power Grids.....	114
Figure H-1: Three Voltage Sources with Their Loads.....	116
Figure H-2: Equivalent Three Phase Circuit .....	117
Figure H-3: Three Voltage Sources with Their Loads and Solar Panels with Circuitry ...	118
Figure H-4: Powertek ISW8300.....	119
Figure H-5: PV Direct Three Voltage Sources with Their Loads and Solar Panels with Circuitry and Power Meters.....	120
Figure H-6: Inverters Direct Three Voltage Sources with Their Loads and Solar Panels with Circuitry and Power Meters.....	121
Figure H-7: Electrical Components in a 3 Phase Power System with PVs and Power Meters.....	122
Figure I-1: Current Transformer Circuit .....	123
Figure I-2: Creation of Current Transformer.....	125
Figure I-3: Voltage Divider Circuit.....	126
Figure R-1: Cheapest Hardware with Minor Engineering.....	185
Figure R-2: Simple Hardware but Requires Driver Writing.....	186
Figure R-3: Expensive Hardware but Easy Engineering .....	187

## **1.0 Introduction**

Climate change is expected to disrupt our living environment and the entire ecosystem of the Earth. If global temperatures increase by just four degrees Celsius, food production would be strained, natural disasters would increase in frequency, and deglaciation would become widespread (Schneider, 2007). In the face of these threats, countries have joined together globally to initiate changes in environmental policy. In 1997, the United Nations Framework Convention on Climate Change (UNFCCC) introduced the Kyoto Protocol, which to date has been signed by many countries. This agreement binds the countries that sign it to reduce their emissions of carbon and other greenhouse gasses based on their then current levels of industrial development and current emissions.

While climate change is a global issue, local communities can have an impact on reducing the emissions of greenhouse gasses. The London Borough of Merton, in an effort to combat global warming, has initiated a program to limit their carbon production. Merton has established the Merton Rule, which requires that all new commercial buildings must derive at least ten percent of their total power from renewable resources. If successful, the minimum requirement will be raised to fifteen percent by 2015 (Hewitt, 2006).

To enforce the Merton Rule, Merton needs to monitor the renewable and nonrenewable energy consumption used by commercial buildings. An effective



monitoring system should retrieve information from the buildings about their energy use and compile it into a central database. Such a system also requires the implementation of equipment to obtain and transmit the energy use data from the buildings.

The development of this system requires several components. First, the initial database needs to be created to store the energy data from these buildings. Second, devices and methods to measure nonrenewable and renewable energy consumption will provide the data for this database. From here a link is necessary for transmission of information from onsite in the buildings to a central database.

This project is the second in the series of three projects intended to build a system which will be used to enforce the requirements for the Merton Rule. The first project was responsible for the design of a system which would allow developers to enter projected energy data about their new constructions and grant the Merton government access to these data. This provides a basis for the enforcement of the Merton Rule, but the Merton government needs a way to constantly monitor the compliance by the building developers. Therefore, the first team also created the framework for an energy monitoring system.

Our project focused on the physical implementation of this monitoring system and the overall viability of the system for future development and implementation throughout Merton and possibly all of London. This was completed by fulfilling three objectives. First, we developed a prototype system, for monitoring the physical energy

usage data from the buildings and transferring the data collected on site to a remote computer. The Merton government would have access to this remote computer to ensure that buildings are complying with the Merton Rule. Second, we explored the possibilities of expanding our system to monitor other renewable energy technologies that are viable in Merton. Finally, we presented the financial benefits of expanding the Merton Rule to all of London and setting the minimum requirement for twenty percent.

The final team in the project sequence will consolidate and finalize the works of the previous two teams and propose the entire system for funding from the various government departments of London and private investors. After making the applications created by the first two teams more user friendly and presentable, they will be responsible for documenting the entire system so that it can be easily understood by various parties, such as politicians or technicians. This series of projects is designed to develop a system of supervising the Merton Rule that will be reproducible in other boroughs of London. Through thorough documentation and testing of the system during development, the final deliverable will show to other local governments the methods and expected costs to feasibly monitor the compliance with their environmental policies.

## **2.0 Background Chapter**

In order to fulfill our objectives, we must first have an understanding of the topics relevant to the growing problem of climate change. This chapter will first provide information on the causes and how this issue can be addressed through the use of renewable energy resources. Then, the Merton Rule and the technologies needed to enforce it will be described. Such technologies and approaches include City Knowledge, Local Online Urban Information System to store data on energy consumption, Geographical Information System, sensors to measure the renewable energy consumption of buildings, and the Merton Hierarchical Online Monitoring and Energy Reporting program to collect energy information.

### **2.1 Climate Change and Greenhouse Gasses**

The temperature of the Earth's surface has been increasing each year, and in the last eleven of twelve years, the Earth's surface has experienced the warmest temperatures since 1850 (United Nations Environment Programme, 2007). This effect of the gradual warming of the Earth is called climate change. Climate change is caused by the release of greenhouse gasses into our atmosphere. These greenhouse gases allow sunlight to enter the atmosphere freely and then strike the Earth's surface. When sunlight reflects off the Earth as radiation, it becomes trapped in the atmosphere by the greenhouse gasses instead of being sent back into space. This radiation contains large

amounts of energy that heats up the atmosphere, leading to warmer and warmer surface temperatures for the Earth.

These greenhouse gases have been causing drastic changes to the climate of the Earth according to the Intergovernmental Panel on Climate Change (IPCC, 2007). In recent decades, an increase in the intensity, duration, and occurrences of high level tropical storms, droughts, and floods has been associated with the increasing amount of greenhouse gases in the atmosphere. (Trenberth, 2007). If temperatures continue to increase, this would affect water and food supply, cause widespread deglaciation and rising sea levels, and threaten biodiversity (United Nations Environment Programme, 2007).

Therefore, the emissions of greenhouse gasses, such as the release of carbon dioxide gasses, must be minimized to combat this growing problem. One solution is to increase the use of renewable energy technologies (United Nations Environment Programme, 2007). This would reduce the need for the carbon producing fossil fuel energy sources and decrease the amount of carbon dioxide gasses released.

### **2.1.1 Valuing Carbon**

Carbon emissions are a large contributor to the problem of climate change. To understand the impact of these carbon emissions, several different methods exist for converting tons of carbon into a monetary figure. These include the trading value of carbon, Stern's social cost of carbon, and Defra's shadow price of carbon.

The first is the trading value of carbon, which is the price that a European Union Allowance (EUA) is being traded for on a certain market, such as the European Climate Exchange (ECX). One EUA is the right to emit one ton of carbon dioxide. The trading value is dependent upon the current environmental policies, the supply and demand of EUAs, and technical indicators of the market (European Climate Exchange, 2008).

The second method is Stern's social cost of carbon, which was developed by the economist Nicholas Stern in the *Stern Review* commissioned by the British government. The social cost is the global cost of carbon taking into account the economic damages of emitting that ton of carbon (Stern, 2006). This is the value of what people would expect to pay today to avoid the future damage of these emissions. To calculate the Stern's social cost, two values are needed. First is the social cost of carbon for "business as usual," which is the cost if no policies were put in place and present day emissions continued. The second value was the social cost of carbon. The difference of these values reflects Stern's social cost of carbon. However, there are some criticisms about Stern's social cost. One example of such is that the discount factor which Stern used to calculate the social cost (Economics Group, Defra, 2007).

The last method, the shadow price of carbon, was developed by the Department of Environment, Food, and Rural Affairs (Defra). It is meant to be used in government appraisals of the United Kingdom. The shadow price uses Stern's social cost as a basis, but takes into account the current political and technological situation (Economics Group, Defra, 2007).

These methods of carbon pricing exist to quantify the cost of present day carbon emissions. In order to combat climate change, these carbon emissions need to be minimized. Certain communities worldwide are taking the initiative in adopting renewable energy policies. The London Borough of Merton, England, has been one of the prime supporters of such policies.

## **2.2 Climate Change Policy in London, England**

At the forefront of environmental policy in London is the Borough of Merton. This region of London is trying to do its part for the environment in the fight against global warming. The Borough of Merton felt that the amount of greenhouses gasses being produced by the use of nonrenewable energy sources in its buildings was excessive, and decided to put a plan in place to combat this problem. In 2003, they became the first regional government in London to adopt its own policy for renewable energy, known as the “Merton Rule.”

### **2.2.1 Background of Merton Rule**

The Merton Rule states that:

“The council will encourage the energy efficient design of buildings and their layout and orientation on site. All new non residential developments above a threshold of 1,000sqm will be expected to incorporate renewable energy production equipment to provide at least 10% of predicted energy requirements. The use of sustainable building

materials and the re-use of materials will also be encouraged, as will the use of recycled aggregates in the construction of buildings. This will be subject to the impact on the amenity of the local environment, taking into account the existing character of the area.” (London Borough of Merton, 2007)

The primary purpose of the rule is to help slow global warming through the reduction of emissions of green house gases. It is also expected that the Merton Rule will help reduce energy costs in the long term, as well as reduce the usage of non-renewable resources. By establishing renewable energy sources companies are expected to have a dependable, environmentally friendly energy source for long into the future. In order to ensure that the rule is enforced, the Merton Rule states that:

“No development shall take place until the Local Planning Authority has approved a report provided by the applicant identifying how the predicted CO<sub>2</sub> emissions of the development will be reduced by at least 10% through the use of onsite renewable energy equipment. The carbon savings which result from this will be above and beyond what is required to comply with Building Regulations. Before any unit is occupied or sold the renewable energy equipment shall have been installed and the local planning authority shall be satisfied that their day to day operation will provide energy for the development for so long as the development remains in existence.” (Hewitt, 2006)

## 2.2.2 Viability and Implementation

Though the Merton rule may have been promulgated, there are barriers to its implementation. The main barriers for the implementation of the Merton Rule correspond to technical aspects and financial aspects. These are the main topics we will consider further.

Technical viability is the first main challenge. Renewable energy technologies require very strict conditions of installation and have intricate installation procedures. Many must be incorporated into the building plans at the initial design phase. Many of the physical factors are a party of the viability. Many of the solar systems require large installation space and building orientation towards the sun. In addition, wind turbines require certain wind patterns, and Biomass systems are heavily dependent on fuel availability and load demand (Hewitt, 2006).

Another barrier is the financial costs the setup causes. Retrofitting already existing buildings causes even more problems because of the requirements for many of the renewable sources. Even placing it in initial plans can increase the already high production costs for commercial buildings, causing a 3 to 5% increase (Hewitt, 2006). The payback time-frame associated with the renewable energy equipment is a second financial factor. With the increased costs as mentioned previously, business owners expect some kind of return. Yet, some of the equipment can have a payback time of up to forty years, making it undesirable for companies to use the technology (Hewitt, 2006).



While there may be plenty of barriers to implementation of the Merton Rule and rules like it, boroughs still continue to adopt them. Through 2004 and 2005, there were an estimated 100 boroughs either adopting (or in the process of adopting) a prescriptive ten percent policy (Hewitt, 2006). Though there was much concern about whether developers would be scared to place buildings in boroughs that have the rule, the first company that built buildings under the rule in Merton still continues to build there (Hewitt, 2006).

### **2.2.3 Future Policy**

Though the Merton Rule has been successful, modifications are being considered. For example, a constant 10% policy does not hold well for all situations. One strict set of rules cannot possibly account for all circumstances. Therefore, Merton is developing a set of rules for different situations which may arise. Their idea is to have percentage targets for the different types of development. Because the costs for solar thermal systems are minimal, Merton is likely to increase the renewable energy requirement to 30% by 2011 (Hewitt, 2006). In cases where only renewable electric energy sources are available it will be reduced to 7.5% (Hewitt, 2006). These are just a few of the changes Merton hopes to make.

Merton also hopes to provide some help for complying with the rule. If companies can prove that it is not viable for them to reach certain goals directly in their building, they can comply with the rule elsewhere by installing off site sources of renewable energy (Hewitt, 2006). Merton is continuing to evaluate buildings and

renewable energy infrastructure in order to best apply the rules and policies it has set in place.

## **2.3 Renewable Energy Sources**

To comply with the Merton Rule, building developers must choose to use one or more renewable energy sources. Many types of renewable sources exist and their applications are dependent upon their intended use, constraints affecting implementation, and people's preferences. The London Borough of Merton has specifically recommended the following renewable energy sources: solar water heater, photovoltaic technology, small wind turbines, ground source heating, biomass heating, and combined heat and power generators. The following sections will describe how each of these energy options function and the advantages and disadvantages of each for building developers.

### **2.3.1 Solar Water Heater**

A form of renewable energy for building developers to consider is the solar water heater. These devices consist of solar energy collectors mounted on roofs, with water circulating pipes soldered to them. Solar water heating systems almost always require a backup system for cloudy days and times of increased demand (US DOE, 2006). These systems would be easy to install in many of the buildings. The setups require some simple panels on roofs or the sides of buildings that can easily be placed

on structures that are already in Merton. Along with some piping and a large storage tank placed somewhere in the facility, solar water heaters could be placed in buildings around Merton.

### **2.3.2 Photovoltaic Power**

Additionally, building managers may choose to use photovoltaic (PV) technology as a source of renewable energy for producing electricity. Photovoltaic technology, similar to solar water heaters, uses sunlight to generate power. While each PV, or solar, cell generates only about one or two watts of electricity, PV cells can be connected to form modules to yield more power (US DOE, 2006). Modules can then be further attached to form arrays to generate an even greater amount of power. This allows a building developer to choose any size of a PV system to accommodate their energy needs. Also, a PV system must be attached to the roof of a building and needs to be exposed to sunlight for the majority of the day. While the price of PV systems varies with the types of roofs that they are attached to, the price continues to decline each year and they have an average lifespan of thirty years with little upkeep (US DOE, 2006). Currently, photovoltaic technology is used often with wind turbines for maximum efficiency. These hybrid wind systems have the ability of providing energy at all times even when winds may be weak.

### **2.3.3 Small Wind Turbines**

An additional option for Merton building managers to consider is the use of small wind turbines, which derive their energy from the wind. A wind turbine uses the kinetic energy from wind and generates mechanical power which can then be converted into electricity. The wind causes the blades of a wind turbine to rotate. This in turn rotates the generator in the main shaft of the turbine to produce electricity. Wind turbines do not emit carbon gasses because they are fueled by the wind, not by combustion of fossil fuels. Also, the price of wind energy is extremely low, costing only between four and six cents per kilowatt-hour (US DOE, 2006). There can be apprehension about the noise and aesthetics of wind turbines, but efforts are being made to mitigate these impacts with further technological advancements.

### **2.3.4 Ground Source Heating**

Additionally, to comply with the Merton Rule, building developers in Merton may consider using ground source heating. A ground source heating system is comprised of three parts (The Energy Saving Trust, 2008). First is the underground pipe, or ground loop, where a mixture of water and anti-freeze collects heat from the warmer soil than the top soil. The second part of the system is the heat pump, which extracts the heat from the mixture being circulated in the ground and distributes it to the building's heating system. The final part of a ground source heating installation is the physical heating system of the building which takes the ground heat and circulates it

through the building. A six to eight kilowatt (KW) ground source heating system typically costs around £7,300 - £11,800 (approximately \$14,600 - \$23,600). Also, depending on the type of fuel being replaced saves about £400 - £800 (approximately \$800 - \$1600) on heating bills and about two to eight tons in carbon dioxide emissions per year on average (The Energy Saving Trust, 2008). The main constraint on a ground source heating system is the amount of land available to run the ground loop under but there are multiple ways to lay the pipe to overcome some of the space restrictions.

### **2.3.5 Biomass Heating**

The London Borough of Merton also suggests biomass heating as a viable source of renewable energy. Biomass is matter which includes all plant and plant-derived material; therefore, all the energy released through biomass heating was originally created through photosynthesis (US DOE, 2006). Biomass heating is accomplished by burning biomass materials and transferring the heat to a water boiler. The water can then be pumped through a loop to supply heat to a building. Using biomass as a source of energy generates no additional greenhouse gasses due to the fact that the carbon released is balanced by the amount of carbon that was captured when the biomass was grown. Also, biomass is organic so most of its production will be domestic, leading to environmental, economic, and security benefits for the country.

### **2.3.6 Combined Heat and Power Generators (CHPs)**

Lastly, the London Borough of Merton most strongly recommends that building managers use combined heat and power (CHP) generators to comply with the Merton Rule. Also known as cogeneration, these plants have the ability to produce both electricity and heat concurrently. Conventional electric power plants convert only one third of their energy supply (Wilson, 2001), usually fossil fuels, into electricity. The rest of the energy supply becomes excess heat generated in the process and is emitted through smokestacks. By capitalizing upon this wasted heat, CHP plants can achieve efficiencies of over seventy percent (Wilson, 2001). The excess heat can in turn be used to produce hot or chilled water, steam, and more electricity. Therefore, CHPs are most effective in buildings with high electricity needs. By using CHPs, more energy can be produced from burning less of a primary energy source and carbon emissions can be reduced.

### **2.4 Information Systems**

Information systems will be integral in the monitoring of energy production and consumption data from both renewable and nonrenewable sources. Information systems allow for the energy information to be collected, stored, and accessed by individuals within the London Borough of Merton. The organization, accessibility, and accuracy of energy information data are paramount in monitoring the Merton Rule. The government of Merton will need to be able to analyze specific building data in order to

assess its compliance with the rule. Using specific approaches to data gathering, the government of Merton will have the ability to track the Merton Rule with greater effectiveness because the data will be readily available and it will reside in clearly defined locations. The data collected can be associated with geospatial data which will allow for easier analysis. These steps will ensure that Merton has adequate means to monitor incoming data, such as energy usage information with specific regard to the Merton Rule. The following sections will provide a brief overview of some of the information systems that will be used to help monitor the Merton Rule.

### **2.4.1 Sensors**

To monitor the renewable and nonrenewable energy consumption of commercial buildings in Merton, sensors will be used. Sensors can measure outputs in the forms of either electrical power or heat.

The process by which sensors can measure electrical power is documented in Figure A, which illustrates Georg Simon Ohm's law regarding relations between currents, resistance, and voltage (NASA, 2006). The energy source generates a current and effectively creates a voltage drop on the electrical load that is consuming the power. With an amp meter and a simple digital volt meter, the power consumed by the load can be calculated. As shown in figure A, the hardware that gathers data from the volt meters and current meters and then computes the power dissipated from the renewable and nonrenewable energy source is the black box. A black box is a term for a device, a system, or an object when it is viewed primarily in terms of its input and

output characteristics. After gathering data, the black box averages the power values over a period of time. Sensors that measure electrical output can be used to measure the outputs of the following renewable energy sources: geothermal technology, combined heat and power generators, wind turbines, and photovoltaic technology.

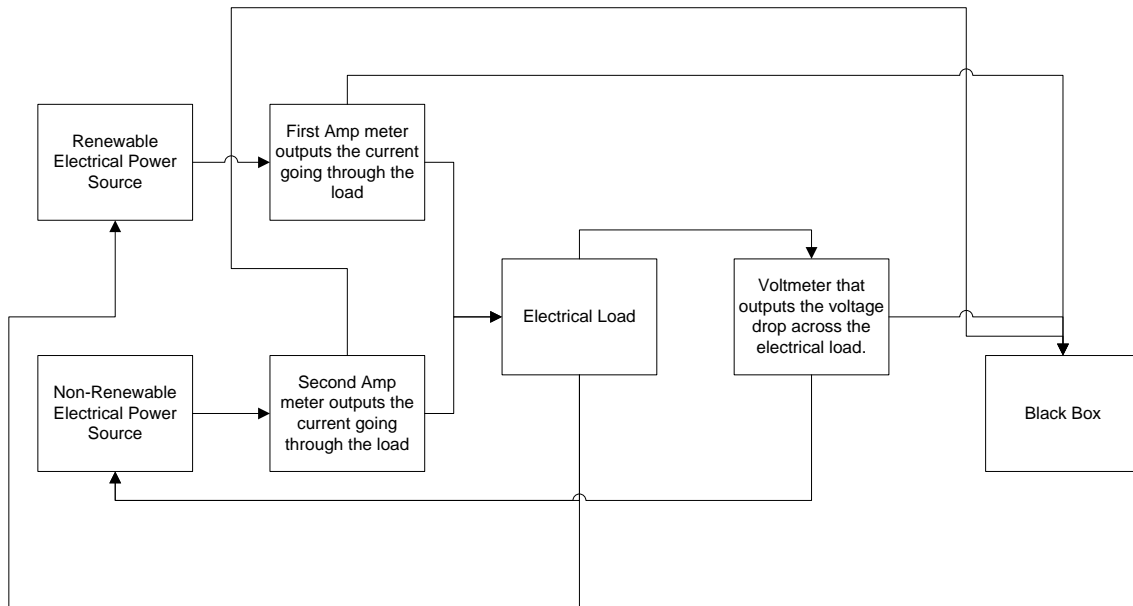

**Figure 2-1: Electrical Power Sensor Procedures**

For energy sources that do not output electricity, temperature sensors are used. Temperature sensors provide temperature values and feed that data into the black box. By measuring the changes in temperature, the black box can compute the energy consumed from the renewable energy source and the nonrenewable energy source. Renewable energy sources that generate heat are biomass heating and solar water heaters.



## **2.4.2 Merton Hierarchical Online Monitoring and Energy Reporting**

Once a sensor is chosen, it must be integrated with a program called MrHomer (Merton Hierarchical Online Monitoring and Energy Reporting), which has been developed by the Merton C08 group. The program is comprised of modules for networking, plug-ins, security, and database.

The most important component for our project is the plug-in module. A plug-in is a small program which is loaded by a host application to provide some specific functionality to the host application. The plug-in module allows clients to integrate external sensors into MrHomer to facilitate data collection from the sources the sensor is monitoring. This allows the use of many different sensors without the MrHomer program needing to know how to gather data from the specific sensor when the program was written. The advantage to this is that the user writes a small amount of C# (C Sharp) code in order to interface the sensor with MrHomer, making it very flexible. Our team will be writing plug-ins to allow the sensors we choose to interface with MrHomer.

## **2.4.3 City Knowledge**

In creating a database to support the Merton Rule, the London Borough of Merton will utilize the approach developed by City Knowledge for efficient and effective data collection and management, also known as data farming. By having reliable and updated data, a municipality can better manage and plan urban projects. To date, City

Knowledge principles have been adopted and proven successful in Boston, Cambridge, Quincy, Worcester, Venice, and London (Carrera, 2005). Developed by Dr. Fabio Carrera, the foundations of City Knowledge include: a “middle-out” approach to collection of data, informational jurisdictions, atomic data management, sustainable updates, information sharing, and interagency coordination (Carrera, 2004).

City Knowledge proposes that data be distributed from the “middle-out.” The middle-out approach combines a bottom-up approach with a top-down approach. In the bottom-up approach, each department in a municipality individually manages and gathers their data as needed. The data from all departments are then overseen by a parent department that compiles the data. However, because each department collects its data as needed, the same information may be collected by several departments repeatedly. This lack of coordination amongst departments causes a redundancy in data gathering and wasted resources. The top-down approach eliminates this potential problem by making the parent department accountable for coordinating the data collection of the sub-departments so that common data can be shared.

Another foundation of City Knowledge is assigning informational jurisdictions for the certification of birth and death of structures, such as commercial buildings in a municipality. This means that specific departments will be responsible for managing certain aspects of data about the buildings. Therefore, one department will collect and manage data, and that data can then be easily shared amongst other departments on a need to know basis by utilizing the middle-out approach.

In establishing jurisdictions, a municipality must collect the data atomically. This requires that data not be collected in a centralized manner, but rather by lower level departments, and parent departments who remain responsible for overseeing and synchronizing the data. This distributes responsibility among all sectors and maximizes the resources available.

After the data are collected by the sub departments and organized by the parent department, the data must have sustainable updates. A city should require that each department update the data routinely and efficiently. This can be done by requiring the departments to perform maintenance checks, instill the value of information maintenance in employees, and utilize free or inexpensive labor (Carrera, 2004). By updating the data regularly, the data remains reliable and effective.

For the middle-out approach to prove successful, the data must be shared. Ideally, this should be done on a voluntary basis and cooperation should be given by the different departments of a municipality. Information sharing can be done vertically within a municipality or horizontally across different cities and town. To facilitate this, a web-based system may be used, such as Geographical Information Systems (GIS), which is described in further detail later.

Finally, Dr. Carrera recommends that a city institute interagency coordination. Data for one department may be entered in a specific format into their system. For data to be shared between all different departments, information must be able to be coded

correctly for all departments. Therefore, it is recommended the related departments discuss and collaborate on the best methods to do so.

#### **2.4.4 Renewable Energy Localized Installation Entry Form**

Utilizing the City Knowledge approach, the group that completed phase one of the project sequence, established a web-based system called Renewable Energy Localized Installation Entry Form (RELIEF). This system requires building developers to enter essential data about their buildings, such as address, developer's name, and renewable sources. These data are referred to as "birth certificates," and they are entered into RELIEF to allow for easy tracking of a building's compliance with the Merton Rule. Although not yet implemented, the data from RELIEF will be put into a Geographical Information System to demonstrate the expected carbon emissions for certain areas.

#### **2.4.5 Geographical Information System (GIS)**

Through the use of the City Knowledge approach, the London Borough of Merton intends to store the information collected more effectively in a Geographical Information System (GIS). GIS allows users to access spatial data about an area, like the London Borough of Merton. GIS's are useful because they store layers of data about the location. The use of GIS allows a municipality to store their data in an organized fashion which facilitates easy access and manipulation.

GIS stores geographical and spatial data about specific locations, such as the London Borough of Merton. The data in the GIS could be anything of relevance to the location such as crime rate, traffic data, and many other types of information that could prove useful to the municipality (*What is GIS*, 2007). The GIS data can be made available in a variety of ways, either through a desktop application connected directly to the database or through a local or published web site. The data contained in the GIS can be used to aid individuals in making decisions in planning procedures as well as many other processes.

The data in GIS are organized into layers (Burgess, Keay, Spanos, Topi, 2005). Each layer holds different information relevant to the location, such as electricity usage, water usage, and heat usage. The data contained in these layers can also be linked together to show relationships between different objects in the system (Burgess et al, 2005). This provides a means to logically group data that may be related or provides some additional context. The layers of data that can be stored along with the geographical information can provide easy and intuitive access to data collected throughout the municipality.

Other municipalities throughout the world have seen the benefits of using GIS and have started to incorporate such systems into their infrastructure. For example, the city of Vienna, Austria has been collecting geographic data since the mid-seventies (Wilmersdorf, 2003) and used their GIS information database to deploy many different services to the city. These services include an incredibly accurate topographic database,

a real estate database for facilitating property management and infrastructure planning, and a zoning database. These GIS-related services are an example of what is possible for municipalities with the use of GIS.

The London Borough of Merton is considering the use of a GIS, called LOUIS (Local Online Information System), to provide an organized and easily accessible interface for the data collected through the use of the City Knowledge approach. Most importantly for this project is the energy production and consumption data for buildings throughout Merton.

#### **2.4.6 Local Online Urban Information System (LOUIS)**

The Local Online Urban Information System (LOUIS) is a GIS that the London Borough of Merton is planning to use to allow access to data regarding their municipality. LOUIS is being developed at City Lab, a research laboratory that is associated with Worcester Polytechnic Institute's Interdisciplinary and Global Studies Division and is directed by Dr. Fabio Carrera. The components of City Lab research and development include City Knowledge, Urban Information Systems such as LOUIS, Urban Technologies, Urban Studies, and Urban Initiatives. City Lab researches and develops both LOUIS and City Knowledge, two technologies that are important to the London Borough of Merton's gathering, organization, and presentation of energy data for the use of monitoring the Merton Rule.

LOUIS is a GIS based on the MassGIS supported open source viewer called OLIVER. LOUIS is being developed with the goal of being embedded into the

infrastructure of a municipality that uses the City Knowledge method of data gathering and is being targeted as such. Current development of LOUIS is primarily focused on two areas. The first is called LOUIS V (Louis the Fifth), which is the actual LOUIS GIS viewer application. The second area of focus is the rewriting of the current LOUIS system to comply with Open Geospatial Consortium standards. Upon completion of LOUIS, City Lab plans to develop several high-level applications targeted to specific departments within a municipality.

The incorporation of LOUIS into the borough of Merton's infrastructure as a way to present the energy consumption and production data, gathered via sensors and the City Knowledge approach, will allow for the Merton Rule to be monitored more easily.

## **2.5 Summary**

The development and implementation of renewable energy producing systems is becoming increasingly important. The London Borough of Merton has begun to take measures to help reduce the carbon emissions which are causing climate change. Merton has created a rule which requires all new non-residential buildings in the borough which are over one thousand square meters in size to derive ten percent of their power from renewable resources. Through the use of information systems, it is possible to monitor the compliance with such mandates on a large scale. However, an important gap in knowledge is how these technologies can be networked together in order to produce a functioning and cohesive system that facilitates scalability, flexibility, and viability for the municipalities who desire to integrate such a system into their

infrastructure. This includes the incorporation of hardware such as energy monitoring sensors into the buildings, establishing a method to gather the data from these sensors remotely by the local authority, exploring the capabilities and the financial practicability of the system. The following chapter will discuss our proposed methods for filling in these gaps in knowledge.



### **3.0 Methodology**

This Interactive Qualifying Project is the second project in a sequence of three which span three seven week periods. The main objective of these projects is to create a full data collection system to monitor energy usage in support of the Merton Rule. The first group had the goal of developing an online database for building developers to input preliminary energy data about their new constructions and creating the framework for our prototype system. Our project set up a system to monitor the energy data onsite in the Merton buildings and transmitted that information back to a central database. The third group will have the objective of combining the efforts of team one and team two into a presentable system to seek funding for full development.

To fulfill our responsibilities in this sequence of projects, we first implemented a working prototype system at The Big Yellow Self Storage Company. Second, we investigated methods that exist for monitoring non-electric renewable sources. The final objective of our project was to explore the financial benefits of an extended Merton Rule that will exist for the residences, commercial buildings, and the local governments of London. Each of these objectives will be described in the following sections.

## **3.1 Establishing a Working Prototype System**

Our first objective was to establish a working prototype system at The Big Yellow Self Storage Company. In order to create the system, we first chose a sensor. We then wrote sample applications for the Merton Rule Monitoring System (MRMS), which is the system including the Onsite Server and an application to request data from the Onsite Server. Lastly, a computer running our Onsite Server application was integrated into The Big Yellow Self Storage Company.

### **3.1.1 Sensor Selection**

Sensors needed to be chosen and installed in The Big Yellow Self Storage Company to monitor the energy generated by the photovoltaic (PV) panels located there and the total output of the electrical grid. This data was desired by the Merton government to ensure that the building was using renewable technologies to generate 10 percent of their total energy consumption. We established the criteria for choosing our sensors after examining the electrical schematics of The Big Yellow Self Storage Company and consulting with Dan Davies, a representative of Solar Century. Solar Century was the company who installed the PV panels at The Big Yellow Self Storage Company. We determined that these sensors must: be able to monitor the energy in kilowatt-hours (kWh) from the PVs and the grid, be able to handle a current of 20 amps generated by the PVs and the grid, correspond with the one phase power system, report the data digitally, and fall within our budget of £200. We compiled a list of sensors that

fit our criteria by using archival research and corresponding with the manufacturers of these sensors via email and phone interviews.

In order to evaluate how to install the sensors, we visited the site of The Big Yellow Self Storage Company. We were able to secure a visit during the third week of our project, and upon our visit, we discovered that there was already a sensor in place installed by the Solar Century engineers. The sensor was a meteocontrol web'log LIGHT+. We also interviewed the site manager, John Jimenez, and we were informed that we would not be able to gain access to the building's grid because of the Data Protection Act (Information Control Office). Because of these two findings, we no longer needed to choose and install a sensor and we were no longer able to install a sensor to monitor the grid of The Big Yellow Self Storage Company.

### **3.1.2 Writing Sample Applications**

After the sensors were chosen, they were integrated into MRMS. The MRMS system had to perform two functions for it to be considered complete. The first function was to gather energy data from a sensor or sensors located in a Merton Rule building. The second requirement was that the system had to provide a way to forward data about the sensors it monitors to a requesting application located off site. The applications included in the MRMS were an Onsite Server program, which retrieves the energy data from the sensor, and an application to request data from the Onsite Server, referred to as the Remote Requesting Application. The two programs were developed

simultaneously and interactions between the two were thoroughly tested each time any new features were implemented into either program.

### **3.1.2.1 Onsite Server Program**

The first program written was the Onsite Server program (OSS). The Onsite Server program runs on a computer installed in the Merton Rule buildings. The program utilizes the MrHomer framework built by team one of the project sequence to provide essential functionality such as Internet communication and interaction via message passing, sensors data retrieval, database management, and energy data encryption for safe transfer of data over the Internet. The program builds on top of this functionality to provide the features required for the Onsite Server. These features include collecting data from the sensors in the building and accepting requests from the Remote Requesting Application for specific data from the sensors it is monitoring. To do this, a sensor plug-in was written which retrieves and stores actual data from the sensor monitoring the photovoltaic panels in a database. In writing the sensor plug-in for the meteocontrol web'log LIGHT+, representatives from meteocontrol were contacted by phone for how the data is stored and transferred by the sensor. Additionally, code was written to allow the OSS to respond to incoming messages from the remote requesting application. Lastly, when requests were received the program forwarded any requested data back to the application.

Once the OSS program was deemed “feature complete,” a state where all of the required functionality is in place, we proceeded to thoroughly test the program. To do so, we used the Remote Requesting Application to interact with the OSS and perform all of the required actions the OSS needed to be able to provide. If any of the tests failed, we traced the source of the problem, and start all of the tests over again to ensure no other areas of the program were detrimentally affected by the changes made. Once the program was thoroughly tested, it was loaded onto the Onsite Server Computer and installed into The Big Yellow Self Storage Company.

### **3.1.2.2 The Remote Requesting Application**

The other application that makes up the Merton Rule Monitoring System (MRMS) is the Remote Requesting Application (RRA). The Remote Requesting Application was also built using the MrHomer framework to provide easy communication between it and the Onsite Server program. The sole purpose of the RRA is to provide a proof of concept to show that sensor data stored in a computer running the Onsite Server program can be requested and transferred on demand. Therefore, the RRA was written to be able to request data from any sensor that the Onsite Server computer is monitoring and to connect to any computer that is running the Onsite Server program.

Once the RRA was fully developed, we tested many different scenarios of interaction between it and the OSS program. Once the tests of the interactions

between the RRA and the OSS consistently passed, we proceeded to install the Onsite Server Computer into The Big Yellow Self Storage Company. Next, we tested the retrieving of data from the OSS program in its final installed state at The Big Yellow Self Storage Company before incorporating a demo of our prototype system into the final presentation.

### **3.1.3 Integrate a Computer into The Big Yellow Self Storage Company**

Lastly, to establish a working system in The Big Yellow Self Storage Company, a laptop, referred to as the Onsite Server Computer, running the Onsite Server program was integrated into The Big Yellow Self Storage Company's network. Before we could perform the installation, we needed to analyze the building's infrastructure and determine what equipment would be needed in order to integrate a computer into their network. To do this, we acquired electrical schematics and noted the areas of interest to our system. Once we had the areas of interest identified, we would be able to focus on those areas during our visit to The Big Yellow Self Storage Company's campus. With these areas of interest in mind, we visited The Big Yellow Self Storage Company and spoke with John Jimenez, the site manager, who showed us how the wiring was laid out in the sections of the building that were important to us. Finally, we were able to use the information learned from the previous steps to determine which equipment was needed in order to install the computer onto their network.

After deciding what equipment was needed, we had to develop a set of criteria for the Onsite Server Computer. These criteria would be based on the following: the power consumption, type of operating system being run on the computer, and available interface ports of the computer. For the first criterion, we needed a computer which had a relatively low power draw because we did not want the monitoring system to draw more power than the renewable energy sources could generate in the building. For the second criterion, we knew we needed a computer running a Microsoft Windows operating system. This is because the MRMS applications were developed in a programming language called C#.NET which can only be run on a computer with a Microsoft operating system installed. For the final criterion, we decided that the computer needed to have one available PCMCIA expansion slot (Personal Computer Memory Card International Association) and one Ethernet port built into the computer. These specifications were needed because the Onsite Server Computer had to have two Ethernet ports so we could connect it to the Internet and the sensor in The Big Yellow Self Storage Company simultaneously. Subsequently, we were able to physically install our prototype system into The Big Yellow Self Storage Company using the equipment determined through our analysis of the building's infrastructure and visits to the site.

### **3.2 Monitoring Methods for Non-Electric Renewable Energy Sources**

The second objective of the project was to complete research into the methods of renewable energy that do not generate electric current. In order to do this, we first began research into how ground source heating, solar thermal water heaters, and

biomass boilers work. In order to further understand these energy methods, we spoke with Martha Cyr, A professor in the Mechanical Engineering Department at Worcester Polytechnic Institute, who has experience in heat and energy transfer in fluids. She provided us with background on how to calculate energy from the measurable values in the system.

After we had a basic understanding of these systems, we contacted Tony Book, the managing director of Riomay Limited. Riomay Limited is a company who manufactures solar water heaters. Tony placed us in contact with RESOL, the company whose devices he uses to monitor his solar thermal water heaters. In addition, we contacted Bob Harris, a developer who used ground source heat pumps in his construction, the Earthdome in London. Mr. Harris put us in contact with Ice Energy, his source for ground source heat pumps. By conducting informal interviews with these sources and looking through the technical documents that were available via their websites, we gained knowledge of how to monitor these systems.

We continued our discussions with the companies, as well as with the Worcester Polytechnic Institute professors, in order to produce presentable diagrams, which labeled a sample system using solar water heaters and a system using ground source heat pumps. Additionally, the diagrams described potential technical set ups including where sensors should be installed to measure the energy generated by the solar water heaters and the ground source heat pumps. Further research was done into alternative sensing devices so as to produce a wider range of useable options. The information was



catalogued in a usable form and provides a general example of a method to monitor a non-electric renewable energy source.

### **3.3 Evaluating the Financial Viability of the Merton Rule**

The Mayor of London is imposing an extended Merton Rule that applies to all of London with an increased minimum requirement that 20 percent of a building's total energy must be generated by renewable technologies (Greater London Authority, 2007). In order to understand the financial implications of this rule, we looked at how it would affect commercial and residential properties of London and the financial incentives of this rule for the London government.

#### **3.3.1 Viability for Commercial Buildings and Residences**

If commercial and residential properties use renewable sources to provide for 20 percent of their total energy, there would be savings from the decreased amount of energy needed to power these structures. We quantified these energy savings that the commercial sector and domestic sector of London would be expected to realize annually. First, we determined the total renewable energy generated in London. This total energy was then separated into either the commercial and domestic sector to calculate the monetary savings in energy per sector.

First, we calculated the total amount of energy (kWh) that would be saved annually from renewable sources in London. Furthermore, to make our calculations more feasible, we assumed that electricity consumption remained the same as present

day and that the renewable technologies used would only supply energy in the form of electricity. Adrian Hewitt, the Principal Environmental Officer for the Merton Council and our project's sponsor, provided us with the estimated quantity needed to produce 20 percent renewable energy per borough on average and the kWh produced by each type of technology per year. The renewable technologies were grouped into three categories: wind turbines, photovoltaic panels, and renewable sources for water heating. Solar thermal water heaters, ground source heating and cooling, biomass boilers, biogas boilers, and combined heat and power plants were included within the group of renewable sources for water heating. To find the total amount of renewable energy produced per an average-sized borough, we multiplied the average quantity of each type of renewable technology by the kWh produced per year and summed these values. To find the total amount of energy produced in London, we multiplied that value by 32, which is the number of boroughs in London.

After we had the total renewable energy generation expected for London, per Mr. Hewitt's recommendations, we delegated one-third of this renewable energy to the domestic sector and the remainder to the commercial sector. Mr. Hewitt also provided us with the cost per kWh, and we multiplied this cost with the renewable energy generated per sector to find the annual savings in energy costs from both sectors.

### **3.3.2 Viability for the London Government**

Secondly, we evaluated two of the financial benefits that come with imposing this extended Merton Rule for the local London governments. These include the avoided

carbon costs from using renewable energy sources and the expansion of the industry for renewable technologies that would accompany such a rule.

In determining the avoided carbon costs, we first determined the total tons of carbon expected to be saved from using these renewable technologies. Again, we assumed that the electricity consumption of London remained the same as present day and that the renewable technologies used would only generate supplemental electricity. To do so, we conferred with Mr. Hewitt and established the following process. We first converted the kWh per annum from each renewable technology calculated previously to tons of carbon dioxide. A factor of 560 tons of CO<sub>2</sub>/kWh was used to convert the energy generated from wind turbines and photovoltaic panels into tons of carbon (National Energy Federation, 2007). A factor of 194 tons of CO<sub>2</sub>/kWh was used to convert the energy generated from water heating into tons of carbon (National Energy Federation, 2007). We summed these values to find the tons of carbon saved by the renewable technologies in an average sized borough and multiplied that number by 32 to find the total saved by London.

We then converted the tons of carbon saved in London into a monetary figure. We used three popular methods for quantifying the value of carbon for comparative analysis. These include the trading value of carbon, Stern's social cost of carbon, and Defra's shadow price of carbon. The first is the trading value of carbon, which is the price that a European Union Allowance (EUA) is being traded for. One EUA is the right to emit one ton of carbon. The prices from the European Climate Exchange (ECX) for the

year of 2008 were averaged to calculate the trading value of carbon to be used. The reason that the prices were averaged was to accommodate for market fluctuations. The second method is Stern's social cost of carbon, which is the global cost of carbon taking into account the economic damages of emitting that ton of carbon (Stern, 2006). To calculate the Stern's social cost, two values were needed. First is the social cost of carbon for "business as usual," which is the cost if no policies were put in place and present day emissions continued. The second value was the social cost of carbon. These values were determined using the present day calculations from a report released by the Department for Environment, Food and Rural Affairs (Defra), entitled "*The Social Cost Of Carbon And The Shadow Price Of Carbon*" (Economics Group, Defra, 2007). The difference of these values reflects Stern's social cost of carbon. The last method, the shadow price of carbon, was developed by Defra to account for criticism directed towards Stern's social cost of carbon and this value was also found from Defra's report. Therefore, we multiplied the tons of carbon by the trading value of carbon, the social cost of carbon, and the shadow price of carbon to determine the respective costs of carbon for London and an average cost for each borough.

Then, to determine the expansion to the industry of renewable technologies from the extended Merton Rule, we calculated the expected profits that would be incurred from purchasing the necessary renewable technologies. Mr. Hewitt developed the following process with us for doing so. The estimated quantities of renewable technologies needed to provide for the extended Merton Rule in an average borough

and the average costs for each of these types of technologies were obtained from Mr. Hewitt. Again, we assumed that the electricity consumption for London remained the same as present day, and the renewable technologies needed would only supply electricity. The total cost incurred for each of technology was determined by multiplying the quantity of that technology by its cost per unit. The average cost per borough was calculated as the sum of the total cost of each technology. Furthermore, the total cost for London was calculated as the average cost per borough multiplied by 32. Therefore, from these calculations the expected costs that a borough and all of London would be expected to pay for renewable technologies were calculated.

### **3.4 Summary**

The final deliverable of our project was the creation of a prototype system for monitoring a building's compliance with the Merton Rule. We also demonstrated that our prototype system could be extended to monitor other renewable technologies. Lastly, we quantified the financial benefits that exist of an extended Merton Rule for commercial and residential buildings and the Greater London Authority. The final group will demonstrate that the prototype system we installed at Big Yellow Self Storage Company as proof that monitoring the Merton Rule is viable. This system will eventually be presented to various government departments and private investors from London for funding to be developed and implemented in London.

## **4.0 Results and Analysis**

The main deliverable of our project is a prototype system that can effectively monitor compliance with the Merton Rule. For a building to comply with the Merton Rule, it must receive at least 10 percent of its overall energy from renewable sources. Therefore, we need to monitor both the energy from renewable energy sources as well as the overall energy being used by the Merton Rule buildings, which are buildings that are required to comply with the Merton Rule. We were not able to access the information on the overall energy usage of the building because of the Data Protection Act (Information Control Office), but we still were able to create a system to monitor the photovoltaic panels. Next, we demonstrated how our system can be expanded to include additional renewable technologies. Lastly, we presented the financial advantages of an extended Merton Rule that applied to all of London. The results and implications of each of those three objectives will be further detailed within this chapter.

### **4.1 Establishing a Working Prototype System**

In order to create a prototype system to monitor the renewable energy generation of the photovoltaic panels at The Big Yellow Self Storage Company, we completed three tasks. First, we evaluated which sensors were appropriate to measure the photovoltaic panels in the building. Then, we wrote a computer system called the Merton Rule Monitoring System (MRMS) which could retrieve the energy data from the

sensor and send it to a remote computer. Lastly, we set up a computer in The Big Yellow Self Storage Company to run the Onsite Server Program. Each of these three tasks will be explained below.

#### **4.1.1 Sensor Selection**

Prior to learning that The Big Yellow Self Storage Company already had a sensor installed, we performed research into feasible sensors to monitor renewable and non-renewable energy sources within The Big Yellow Self Storage Company. Based on the criteria developed in the methodology chapter, we found many sensors that would be viable to monitor both the building's main power grid and the photovoltaic panels (PV) generating renewable energy for The Big Yellow Self Storage Company. These include the TED series of sensors, the Powertek ISW 8001, the Wattson sensor, and the meteocontrol web'log LIGHT+. All these sensors were suitable for a single phase system, which refers to how power is converted once it reaches a building. Single phase systems are used in residential and light commercial buildings where mostly light and heating are required.

The TED sensors are manufactured by the American based company, The Energy Detective. The sensors in the TED series were well within our budget and the cheapest of the four possibilities, with a maximum price of \$209.95 (approximately £105). They would be suitable for monitoring a single phase system and can handle at least 100 amps. However, with an accuracy of  $\pm 2\%$  (The Energy Detective, 2008) these sensors are not as accurate as the commercial grade sensors, such as the products from

Powertek and meteocontrol. In conjunction with the sensor, we would recommend the purchase of TED Footprints, software that interacts with these sensors via a USB plug. The software costs an additional \$44.95 (approximately £89.90). TED Footprints logs its data in Excel format, which is a data format that our MRMS could interact with to retrieve that data.

The Powertek ISW 8001, which costs £395 (approximately \$750), is the most expensive of the four sensors we evaluated. However, it is the most accurate with an accuracy of  $\pm 0.2\%$ , (Powertek, 2008). This sensor can also be connected to a computer via a USB cable, but since the sensor does not derive the energy data in kilowatt-hours, more accommodations would have to be written in the MRMS programs.

The Wattson, developed by DIY Kyoto, costs £149.50 (approximately \$300). The Wattson's data is retrieved wirelessly by their software, the Holmes, free of charge. In contacting DIY Kyoto, we were informed that our program would be unable to retrieve the data from the Holmes. However, a new version of the Holmes was being written to be released at the end of April that would allow us to do so.

Lastly, the meteocontrol web'log LIGHT+ was the sensor that was already installed in The Big Yellow Self Storage Company. This sensor costs 375 euros (approximately \$600 or £300). The data from this sensor is stored as ASCII text and can be connected to a computer to transfer data via Ethernet. How we integrated the meteocontrol with MRMS will be discussed in greater detail in the following sections.



In addition, we intended to monitor the PV's energy output as well as the grid's energy output for our project. However, we were told by John Jiminez, the site manager at The Big Yellow Self Storage Company that we were not allowed to install a sensor to measure the energy from the main power grid due to restrictions set forth in the Data Protection Act. After learning this, we contacted the Information Commissioners Office (ICO), the government body which regulates the Data Protection Act, to obtain confirmation as to why we were unable to monitor the electrical grid of The Big Yellow Self Storage Company. However, they did not respond to our inquiry.

#### **4.1.2 Writing Sample Applications**

Over the course of the term, we wrote a computer program, called the Merton Rule Monitoring System (MRMS), to collect the energy data from the sensor. The MRMS and a CD-ROM containing the MRMS applications, installation files, and source code for The MRMS were the two deliverables for this section of the project. The MRMS contains two sample applications. These are an Onsite Server (OSS) Program and a Remote Requesting Application (RRA). These two programs were written to communicate with each other over the Internet to relay information about sensors being monitored in a Merton Rule Building. The interactions between the programs show how the Merton Rule could be monitored from an offsite location. The final interactions between the programs provide a remote user with a way to get real-time (constant updates as soon as they are available) or on-demand (upon request) data from any sensor the Onsite Server is monitoring in the Merton Rule building.

The second deliverable for this portion of the project was a CD-ROM containing the two applications and the source code for them, the MrHomer framework and source code, installation instructions, and all the files needed to install the system on a computer. The explanations of these contents of the CD-ROM are located in Appendix K. A backup of the CD in electronic form is located on our Sourceforge project entitled [London Merton IQP Sequence](#). Sourceforge is an online collaboration and backup system run by WPI (<http://sourceforge.wpi.edu>).

While MRMS shows the required interactions to demonstrate the feasibility of monitoring compliance with the Merton Rule, it was narrowly focused because our project is intended only to be a proof of concept. If this system is to be used for further development, it would need to be restructured in such a way that is not specific to The Big Yellow Self Storage Company installation, which the current MRMS is. However, since it would involve writing a substantially larger amount of code, we decided to write the programs for our proof of concept system specifically for The Big Yellow Self Storage Company's configuration. Suggestions on how to develop the MRMS to be more flexible are located in the Recommendations chapter.

#### **4.1.2.1 Onsite Server Program**

The first application in the MRMS is the Onsite Server (OSS) Program. The main purpose of the OSS is to collect data from the meteocontrol sensor monitoring the photovoltaic panels located in The Big Yellow Self Storage Company's building. Its secondary purpose is to wait for connections from remote applications and forward

data from the sensors it is monitoring upon request. Information on significant events that can occur during the execution of the OSS Program and how to use the Onsite Server is located in Appendix M.

The OSS satisfies both of these required purposes for our prototype system. However, as discussed above, it is narrowly focused on the specific purposes required for our prototype system. The OSS program could be fleshed out to be more flexible and allow the installing of many different sensors if the need arises.

During the third week of the project, we learned through contact with meteocontrol that the web'log LIGHT+ stores a data file of its readings in a FTP (File Transfer Protocol) server. To allow the OSS to access this data we used a free Library, which is a collection of code which provides specific functionality, from Enterprise Distributed Technologies (<http://www.enterprisedt.com/>) called edtFTPnet. This company allows its visitors to use the code located there in software which complies with the LGPL license (<http://www.gnu.org/licenses/lgpl.txt>). The LGPL regulates how code can be used and distributed. Consequently, since the OSS uses edtFTPnet, it is also licensed under the LGPL.

Over the course of the development of the OSS, a few minor problems were overcome, allowing for us to write the OSS to provide the necessary functionality. The biggest problem that occurred was that we could not test the program in a real world setting until we actually installed it into The Big Yellow Self Storage Company. Also, we were delayed in being able to interact with the sensor when we arrived at The Big

Yellow Self Storage Company during the fifth week of the project and learned that the PV panels and monitoring equipment would not be active until week six. After learning this, we contacted meteocontrol in order to obtain a sample data file that the meteocontrol sensor would create so we could continue development of the OSS. However, this was still a significant barrier to overcome because we were forced to test the program with data being produced by the application instead of an actual sensor until week 6 of our project. This left us under a week to perform the install of the system and test it with the sensor installed in The Big Yellow Self Storage Company before our final presentation.

#### **4.1.2.2 The Remote Requesting Application**

The second program in the MRMS is the Remote Requesting Application (RRA). The RRA's main purpose is to connect to computers running the OSS program and request sensor data from it. There are several ways that this is accomplished, and they are discussed in Appendix O.

The RRA achieves its main purpose as required for our prototype system. However, like the OSS, it is also narrowly focused on those goals. Therefore in its current state, it is focused on proving that it is possible to receive data from a remote computer running the OSS program. During development, we added some extra functionality so that data requested by the RAA can be logged in a database which could then be tagged to a Geographical Information Systems (GIS) map. This functionality is not used in our

prototype system simply because it was not needed, but it is in place so that the next team can use it for their final system mockup.

The RRA will be the program used to present and retrieve data from the computer located at The Big Yellow Self Storage Company which is running the OSS program. We were able to retrieve data from the sensor monitoring the photovoltaic panels at The Big Yellow Self Storage Company in real time. This provided proof that it is feasible to be able to monitor these Merton Rule buildings remotely, and the success of this specific proof of concept implies that it is possible to expand this to a central monitoring system which could enforce compliance with the Merton Rule.

### **4.1.3 Integrate a Computer into The Big Yellow Self Storage Company**

To complete our prototype system, we installed a computer running the OSS program into The Big Yellow Self Storage Company. To determine how we were going to install the system, we acquired the electrical schematics for The Big Yellow Self Storage Company through contact with Dan Davies of Solar Century, an engineer at the company that installed the photovoltaic panels in the building. Once we had the electrical schematics, we identified the areas of interest as any area having to do with the photovoltaic panels and the monitoring equipment attached to them.

Once we knew the areas of interest, we visited The Big Yellow Self Storage Company and spoke with the Site Construction Manager John Jimenez. After our conversation with John, we had enough information to know that the wiring already

installed in the building dictated that we could integrate our system with a variety of equipment combinations. After engaging in personal communication with Jesse Banning, a systems administrator in the Worcester Polytechnic Institute Computer Science department, we decided to install the system using one network switch, one laptop computer with built in Ethernet port and an available PCMCIA expansion slot, and one PCMCIA Ethernet card. A PCMCIA slot is a port in most laptops which allows for expansion cards, such as cards with extra Ethernet port, to be installed into the computer. We needed this PCMCIA Ethernet card so we could simultaneously connect both the sensor and the Internet to the Onsite Server computer. The Big Yellow Self Storage Company proposed install diagram and device explanation is as follows:

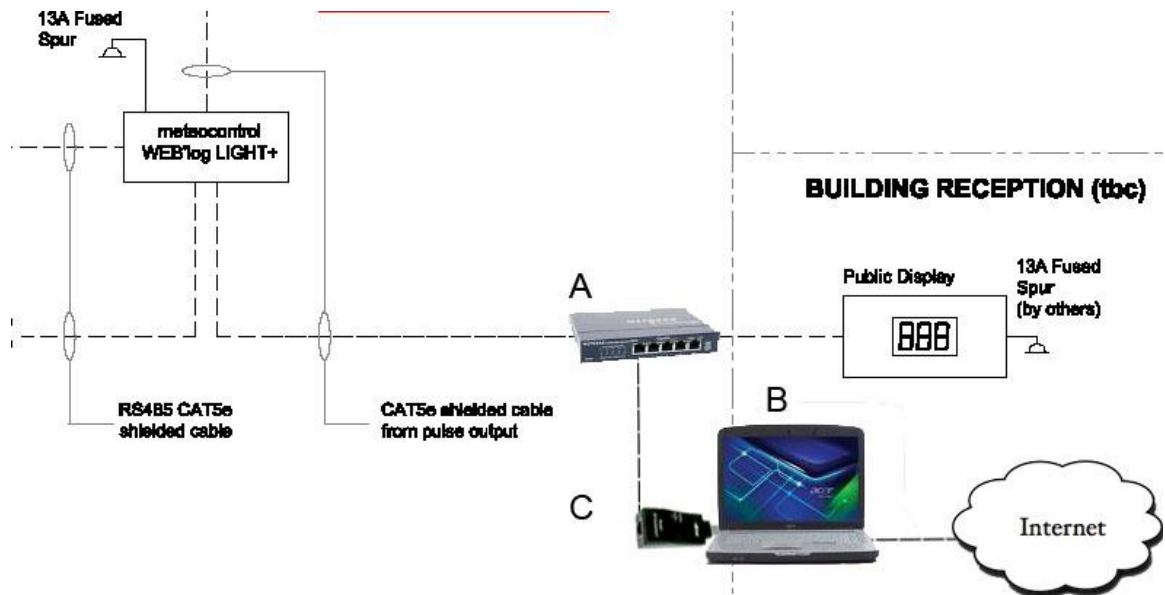

#### **Figure 4-1: Proposed Install Diagram for Big Yellow Self Storage Company**

A Netgear 5 port network switch (Label A) was required in order to split the connection to the meteocontrol web'log LIGHT+ between the Onsite Server Computer and the Public Display Device in The Big Yellow Self Storage Company's building. A laptop (Label B) was purchased to serve as the Onsite Server computer. Ideally, this computer would have an available PCMCIA expansion slot. However we did not have enough time to order a computer with a PCMCIA slot. An Ethernet to USB converter (Label C) was used to allow the Onsite Server Computer to connect to the Internet and the meteocontrol web'log LIGHT+ simultaneously. This was used in place of a PCMCIA Ethernet card due to time constraints apparent when buying a laptop computer.

Due to time and availability constraints, we were unable to obtain a laptop with an available PCMCIA slot; the laptop we purchased had a different expansion port (called an ExpressCard slot). Due to the fact that the Ethernet expansion card for our laptop cost fifty pounds, we decided to use an Ethernet to USB converter in place of the Ethernet expansion card.

Upon returning to The Big Yellow Self Storage Company during the fifth week of our project to perform a preliminary install of the network switch and test communication between the Onsite Server Computer and the meteocontrol sensor installed, we learned from John Jimenez that the wiring in place was not the same as what we were originally told and the PV panels were not up and running yet. This

forced our team to come up with a new install diagram based on the new wiring plans

John Jimenez briefly discussed with us. The revised install diagram is as follows:

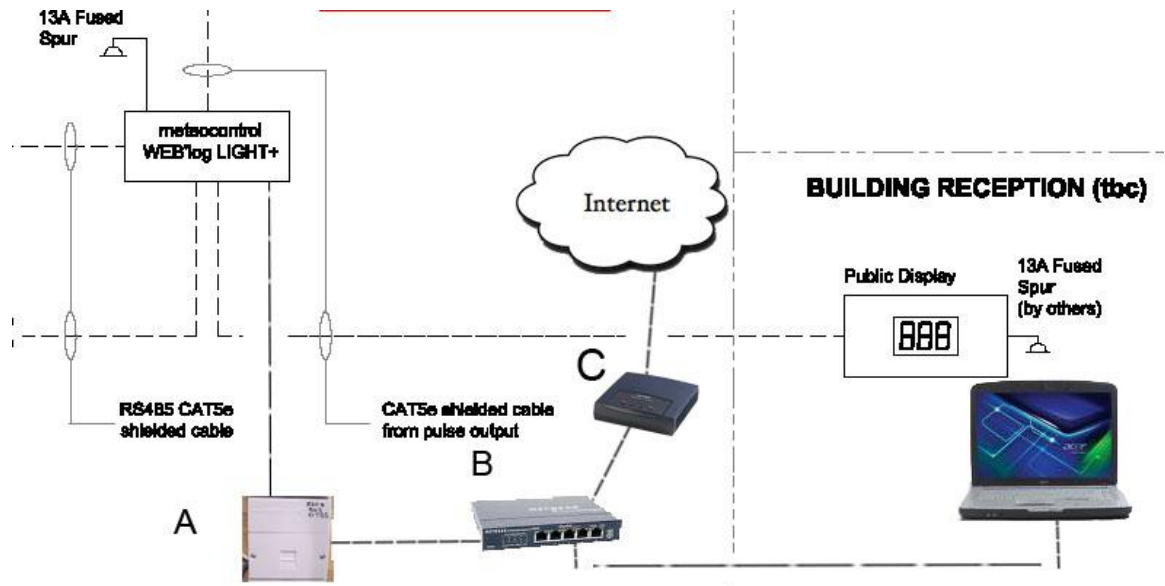

**Figure 4 -2: Final Big Yellow Self Storage Company Install Diagram**

The meteocontrol sensor installed in The Big Yellow Self Storage Company was wired to an input box (Label A) with an Ethernet port. The Big Yellow Self Storage Company purchased a broadband modem (Label C), which is a device which allows for connection to the internet. The modem was plugged into the network switch (Label B) that our sponsor purchased, along with the Onsite Server Computer, and meteocontrol sensor to allow for the Onsite Server to simultaneously communicate with the internet and the meteocontrol sensor.

The new wiring setup involved The Big Yellow Self Storage Company wiring the cable from the meteocontrol sensor to an input box which can accept Ethernet cable connections. In addition, The Big Yellow Self Storage Company purchased a broadband



modem which would allow connection to the internet. These were then wired into a network switch which would accept cables from the input box, Onsite Server Computer, and the Internet.

Once the PV panels and wiring were installed, we visited The Big Yellow Self Storage Company for the final time to install our Onsite Server Computer. Upon wiring the computer into the network switch, we were able to locate the sensor on the network and, after modifying the Onsite Server program, were able to retrieve data from it. After leaving the Onsite Server Computer at the building, we attempted to test the interactions between the Remote Requesting Application and the Onsite Server we installed from over the internet but were unable to connect to the computer at The Big Yellow Self Storage Company. Upon visiting two more times, we were able to configure the broadband modem to allow our Onsite Server Program to receive connections from the internet. After the successful configuration, were able to test interactions between the Onsite Server and the Remote Requesting Application before our final presentation of the system. This allowed us to incorporate a live demonstration of our prototype system in The Big Yellow Self Storage Company into our final presentation in Merton.

## **4.2 Monitoring Methods for Non-Electric Renewable Energy Sources**

In order expand the scope of our monitoring capabilities, we researched methods to monitor other renewable energy sources that are viable in Merton. These methods are solar thermal water heaters, ground source heat pumps, and biomass boilers. For solar thermal water heaters and ground source heaters to operate, a

significant amount of power is required. These systems generally operate with a coefficient of performance (CoP) of 3-4. This means that for every kilowatt of electric power that they use, they generate 3-4 kilowatts of power. Unfortunately, they do not generate energy in the same manner and therefore require different systems to monitor them. We have found companies that monitor these systems already, have developed potential monitoring methods, as well as identified devices with which to monitor these systems.

#### **4.2.1 Solar Thermal Water Heaters**

The source with the most widely available information regarding monitoring methods is solar thermal water heaters. After contacting Tony Book, a frequent user of solar thermal heaters, we learned he often uses the devices produced by RESOL to monitor his installations. By examining their technical documents (RESOL, 2007) we were able to gain some idea of the physical setup of a system. After speaking with Martha Cyr, a professor in the Mechanical Engineering Department at Worcester Polytechnic Institute, in order to gain further understanding of the scientific equations involved, we were able to produce a diagram which shows where we would monitor the temperatures as well as the flow rates involved in solar thermal water heaters (Figure 4-3).

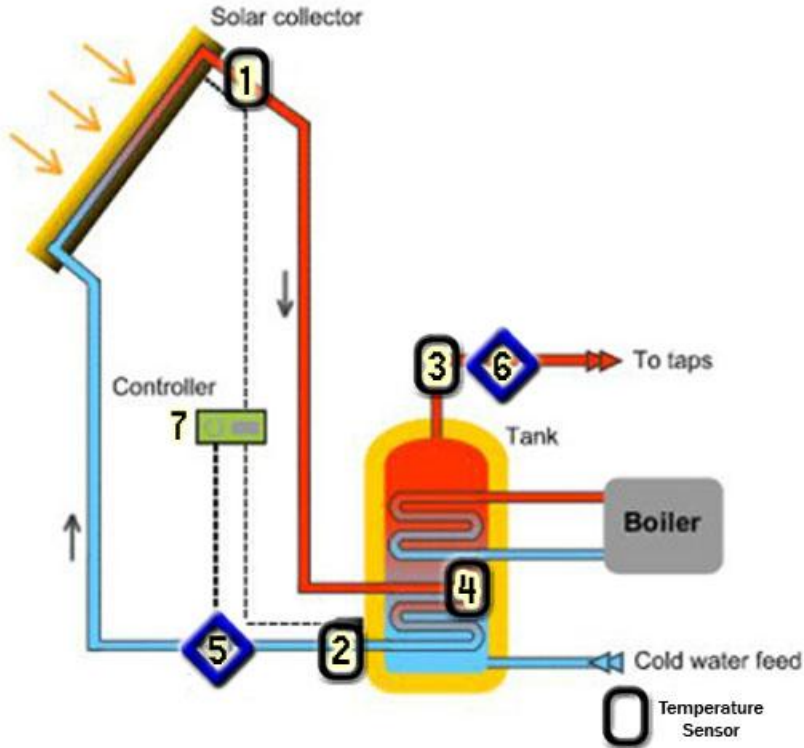

**Figure 4-3: Solar Thermal Water Heater Monitors**

(original image from <http://www.therenewableenergycentre.co.uk/solar-heating>)

Through the monitoring of various temperature changes and the liquid velocity throughout the system, we are able to calculate the energy generated by the thermal heating as well as the energy being used by the system as a whole. This allows us to quantify how much energy the system is saving the customer. For a full analysis of the system and scientific equations, please see Appendix B.

The equipment sold by the RESOL Company would be viable for all parts of this process. These devices or devices similar to these would be viable for integration into our system. They output data into a central device which turns these values into the energy data. This device can then be hooked into a data logger. This data logger is able to provide data directly into a computer, which is ideal for our system. The devices provided by RESOL and their functions can be seen in Appendix C.

### **4.2.2 Ground Source Heat Pumps**

After doing research into how ground source heat pumps work, we spoke with Bob Harris, a progressive environmental developer in London. Mr. Harris directed us to Ice Energy, a company that installs and monitors ground source heat pumps. Through personal discussions with this company, we decided that ground source heat pumps would be monitored in a similar manner to that of solar thermal water heaters. Ground source heat pumps draw energy from the ground just like the solar thermal water heaters gain energy from the sun. This energy is then transferred via the heat pump to other parts of the system. Once again through the usage of temperature and flow rate sensors, the energy generation can be monitored. We have developed a basic model of how a ground source heat pump may work, but could not gain much insight into how Ice Energy monitors them, as the information is of great value to their company due to the research time spent on it. A basic setup of sensor location can be seen in Figure 4-4.

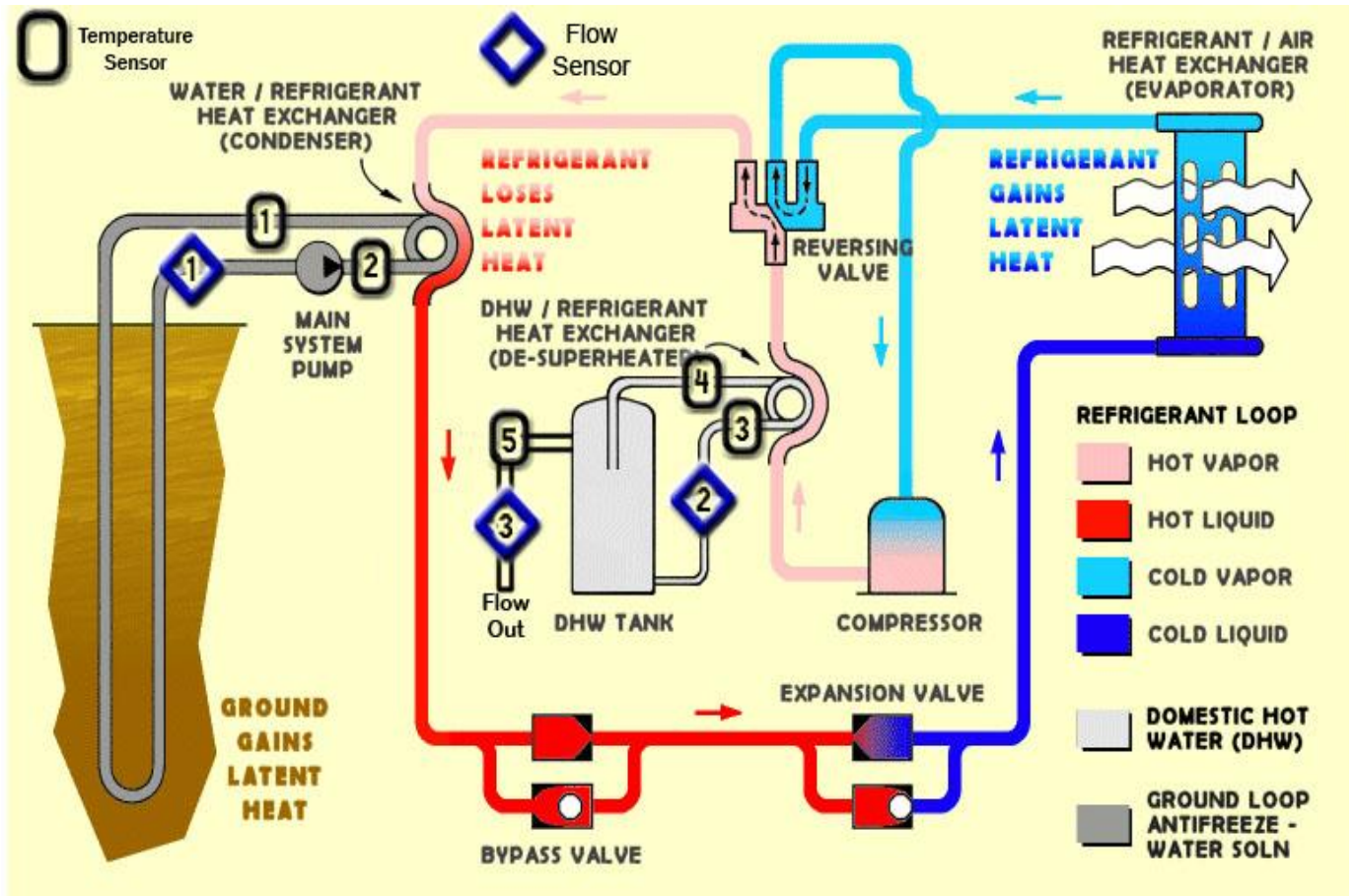

Figure 4-4: Ground Source Heat Pumps

Original Image from <http://www.geo4va.vt.edu/A3/GHP-cooling.gif>

After searching the websites for licensed ground source heat pump providers in London (Dept. of BERR 2008), we were unable to find sufficient information to create a complete model. This is a rough idea of what a monitoring system could look like for a basic ground source heat setup.

### **4.2.3 Biomass Boilers**

The final non-electric renewable energy source that is viable in Merton, biomass boilers, requires a unique approach in order to monitor it. As they behave in a similar manner to regular boilers, they generate the same amount of carbon emissions. In order for them to be carbon neutral, the user must replenish the plant life used to fuel the biomass boiler. In order to monitor this, the individual will have to provide monthly invoices for the mass and type of biomass which they are burning. In addition, they will also have to provide documentation of the plant life which was planted in order to make the system carbon neutral. These are the methods we were able to identify with our basic knowledge of the biomass boiler systems.

## **4.3 Evaluating the Financial Viability of the Merton Rule**

When the Mayor of London imposes the extended Merton Rule for all of London, requiring a minimum renewable energy production of twenty percent, several parties will experience energy savings. This includes commercial and residential buildings and the local governments of London. The following subsections details these savings.

### **4.3.1 Viability for Commercial Buildings and Residences**

Because the commercial sector and the residential sector of London will be obligated to use renewable technology to provide for twenty percent of their net energy consumption, the extended Merton Rule provides savings in energy costs for them. The commercial sector is expected to save £2,640,000 and the residential sector is expected

to save £3,740,000 annually as calculated below. Simplifying assumptions had to be made so that these calculations were feasible. First, we assumed that the renewable sources installed in these buildings are only generating supplemental electricity, but they may also be generating energy that would be powered by fuel and gas. Also, we assumed that the electricity consumption of London would remain the same. However, regardless of these assumptions, the buildings of London would still incur energy savings.

In order to compute the energy savings of the two sectors, we first had to calculate the total amount of energy (kWh) saved from renewable sources annually in London with the extended Merton Rule. Figure 4-5 shows how we were able to calculate this:

Types of Renewable Technologies	kWh Per Annum	Tons of CO <sub>2</sub>
Wind Turbines (15 kW)	500,000	280
Photovoltaic Panels (kWp)	212,500	119
Water Heating (m <sup>2</sup> of solar thermal energy) <i>Solar Thermal</i> <i>Ground Source Heating and Cooling</i> <i>Biomass</i> <i>Biogas</i> <i>Combined Heat and Power</i>	1,350,000	262
Average per Borough	2,062,500	661
Total for London (x32 Boroughs)	66,000,000	21,149

**Figure 4-5: Calculation of Energy Saved from Renewable Sources**

The quantity needed to provide for the extended Merton Rule in an average borough and kWh produced per year of each renewable technology were provided by Adrian Hewitt. These figures were multiplied to produce the kWh per annum generated by each renewable technology. That column was summed to find the total kWh annually produced from these renewable sources in an average sized borough. The total for London was calculated by multiplying the average borough energy by 32.

The Figure 4-6 details the final calculations to determine the cumulative annual savings for commercial and residential properties in London:



Sector	Renewable Energy Generation (%)	Renewable Energy Generation (kWh)	Cost per kWh (£)	Annual Savings (£)
Commercial	9%	4,900,000	£0.15	£735,000
Domestic	3%	1,980,000	£0.17	£336,600

**Figure 4-6: Annual Savings of Commercial and Domestic Sectors**

The percentages of the total renewable energy given by Mr. Hewitt were applied to 66,000,000 kWh, the total renewable energy expected to be generated by London calculated in Figure 4-5. This produced the values for the renewable energy generated by each sector. This was then multiplied by the cost per kWh also provided by Mr. Hewitt to produce the final savings. Therefore, by utilizing renewable sources to comply with this extended Merton Rule, commercial and residential buildings would pay less for energy because at least twenty percent of their energy would be supplemented by those sources.

### 4.3.2 Viability for the London Government

Additionally, when the extended Merton Rule is adopted in London, there will be benefits for the local governments of London as well (Greater London Authority, 2007). First, London would be saved from potential carbon emissions. A price on these avoided carbon emissions were calculated using the trading value of carbon, Stern’s social cost of carbon, and Defra’s shadow price of carbon to illustrate the annual savings. Secondly,

there would be an expansion to the industry of renewable technologies meaning more jobs for the citizens of London. The profits to this industry were also calculated. For both of these calculations, we assumed that future electricity consumption of London would remain the same as present day and the renewable technologies used would only be generating electricity.

The annual carbon savings for London according to the trading value of carbon, Stern’s social cost of carbon, and Defra’s shadow price of carbon are £372,103, £719,059, and £528,720 respectively. Figure 4-7 shows the values of the trading value (European Climate Exchange), social cost (Economics Group, Defra, 2007), and shadow price of carbon (Economics Group, Defra, 2007).

	Total Carbon Saved Roadside	City Total Value (£) <sup>1</sup>	City Total Value (£) <sup>2</sup>	Social Cost (£/ton) <sup>3</sup>	Shadow Price (£/ton) <sup>4</sup>
Average Roadside	61	£502	£168	£271	£528
Total London	219	£372,103	£27,036	£719,059	£528,720

<sup>1</sup> 285 cars per hour x average fuel efficiency x 225 cars per hour x average fuel efficiency x EX  
<sup>2</sup> 0.7 x EX per tonne of carbon saved  
<sup>3</sup> (£29,100 - £3,100)  
<sup>4</sup> £27,036

**Figure 4-7: Total Annual Carbon Savings**

The savings calculated according to the trading value were lowest as expected because the carbon saved is not considered a tradable commodity. Therefore, the true value of this carbon is greater. Also, Defra’s shadow price is lower than Stern’s social cost because Defra’s shadow price uses Stern’s social cost as a basis, but is adjusted to

accommodate some of the criticisms direct at Stern’s social cost (Economics Group, Defra).

In order to determine the carbon savings for London, first we needed to determine the total tons of carbon dioxide saved annually from the extended Merton Rule. These were found by converting the kWh per annum produced from the different types of renewable technologies into tons of carbon dioxide from Figure 4-5 based on the coefficients determined in the Methodology. Figure 4-8 shows the quantity of carbon saved by each renewable technology and the total tons of carbon saved for all of London.

Types of Renewable Technologies	kWh Per Annum	Tons of CO <sub>2</sub>
<b>Wind Turbines (15 kW)</b>	<b>500,000</b>	<b>280</b>
<b>Photovoltaic Panels (kWp)</b>	<b>212,500</b>	<b>119</b>
<b>Water Heating (m<sup>2</sup> of solar thermal energy)</b> <i>Solar Thermal</i> <i>Ground Source Heating and Cooling</i> <i>Biomass</i> <i>Biogas</i> <i>Combined Heat and Power</i>	<b>1,350,000</b>	<b>262</b>
Average per Borough	2,062,500	661
Total for London (x32 Boroughs)	66,000,000	21,149

**Figure 4-8: Calculation of Tons of CO2 Emitted**

Figure 4-7 shows the values of the trading value (European Climate Exchange), social cost (Economics Group, Defra, 2007), and shadow price of carbon (Economics Group, Defra, 2007) that were multiplied by the tons of carbon saved by London and each

borough. We were expecting that the savings in carbon costs would be in the range of millions of pounds annually. Therefore, these savings were not as substantial as we had assumed. This is largely because the cost of carbon was lower than anticipated.

Another benefit of this extended Merton Rule is that there would be a great increase in demand for renewable technologies. This was demonstrated by calculating the expected profits for the overall market of renewable technologies. £102,400,000 worth of renewable technologies would need to be purchased in London. As a result of this, there would be an increase in jobs in those companies in and related to the market. Additionally, as demand increased, the price of such technologies would decrease assuming that the supply of these technologies can sustain demand, making it more feasible for the Merton Rule to become more widespread.

The quantity of renewable technologies needed for London and the cost of each unit of these technologies was provided by Mr. Hewitt. Figure 4-9 details the amount of renewable technologies needed for all of London and the average needed for each borough.

Types of Renewable Technologies	Quantity	Capital Value per Unit	Total Investment
Wind Turbines (5kw to 50kW)	25	£30,000	£750,000
Photovoltaic Panels (kWp)	250	£5,000	£1,250,000
Water Heating (m <sup>2</sup> of solar thermal energy) <i>Solar Thermal</i> <i>Ground Source Heating and Cooling</i> <i>Biomass</i> <i>Biogas</i> <i>Combined Heat and Power*</i>	3,000	£400	£1,200,000
Average Investment per Borough			£3,200,000
Total Investment for London (x32 Boroughs)			£102,400,000

\*Combined heat and power plants are not always considered a renewable technology

**Figure 4-9: Renewable Technologies Industry Potential Profits**

## 4.4 Summary

Our project produced a working prototype system in The Big Yellow Self Storage Company to demonstrate that the Merton Rule can be successfully monitored. This working prototype system can be expanded with the research that we completed in monitoring non-electric renewable technologies. Lastly, an extended version of the Merton Rule will be implemented in London, and we have determined the financial incentives associated with it for commercial and residential buildings and the local governments of London.

At the end of the three project sequence, our system will be presented to potential investors to receive funding so that it may be implemented throughout

London. The following chapter will discuss some of our recommendations in how to fully develop our system.

## **5.0 Recommendations**

After completing our three objectives, we have developed recommendations for further research and development of the project. This section is separated into recommendations for each of our project's three objectives plus a section of guidelines for the E Term team to complete.

### **5.1 Establishing Working Prototype system at The Big Yellow Self Storage Company**

One of the objectives of our project was to establish a working prototype system at The Big Yellow Self Storage Company. During the completion of this objective, we developed recommendations for further development or research related to these subtasks: sensor selection, writing sample applications for the Merton Rule Monitoring System, and installing the MRMS into The Big Yellow Self Storage Company building.

#### **5.1.1 Sensor Selection**

During our project, were unable to install a sensor into The Big Yellow Self Storage Company since a meteocontrol sensor was already monitoring the PV panels. However, during our research we developed recommendations for viable sensors and installation methods:

- **Monitoring of Single Phase Power Systems**

For buildings which use a single phase power system complemented by a single renewable energy source, the most cost effective install would consist of two TED model sensors. One of the TED sensors would be used to monitor the main power grid of the building while the other would be used to monitor energy flow from the renewable resource. These sensors have USB out ports which can be wired to the Onsite Server computer and tracked using the TED Footprints software developed by The Energy Detective. The TED Footprints software logs data in a Microsoft Excel file which can be easily read by the Onsite Server program for reporting.

### **5.1.2 Write sample applications for the Merton Rule Monitoring System**

To complete the objective of establishing a working prototype system at The Big Yellow Self Storage Company, we had to write a computer program called the Merton Rule Monitoring System (MRMS). The MRMS includes the Onsite Server program (OSS) and the Remote Requesting Application (RRA). After developing these programs, we have recommendations for further development:

- **Plug-in Wizard**

The plug-in wizard for the MRMS would be a small application that guides the user through the process of integrating a new sensor into their already existing MRMS installation. It would modify or create the appropriate files, rebuild the project and restart the application upon completion. If the Onsite Server program is developed



more generally, the process of adding new sensors could be as simple as writing data into a configuration file and reloading the program. The value to this extension is extremely high because it means that if companies wish to integrate a new sensor into their existing MRMS installation, they will not have to hire contract programmers to write the plug-ins required. They could just click through the plug-in wizard and it would automate the process.

- **Installer Program**

The MRMS already has small install scripts, which are files meant to automate the process of installing our programs. However, these scripts do not work for all Microsoft Operating Systems (such as Windows Vista). An installer program for the MRMS that allows the user to customize the installation and also automates the install of the Microsoft SQL Server 2005 would be ideal. The value of this extension would be that it would make the MRMS easily deployable by a Merton Rule Building's System Administrator. This would avoid having to send someone to install the MRMS for each Merton Rule building, which would save the enforcing body time and money.

- **Develop the Central Merton Server Program in Place of the Remote Requesting Application**

The Remote Requesting Application (RRA) was purely a proof of concept and is not feature complete for a final server program. Therefore, in the final system, a program which would act as the "Merton Server" would need to be written. The central "Merton Server" program would replace the RRA in our prototype system. The "Merton Server"

would need to have a way for an Onsite Server Computers to register with it. This would allow the “Merton Server” to periodically log data from Onsite Server Computers throughout Merton and tag their data to a GIS map. This would allow the monitoring of the Merton Rule to be fully automated to provide access up to date information through the Merton GIS. The “Merton Server” is essential to a final system along with LOUIS integration and a more general Onsite Server Program.

- **Make the Onsite Server Program More Generalized**

The Onsite Server program (OSS) we developed was just a proof of concept. For a real-world system, the OSS should be developed in a more generalized manner. By this we mean that the sensors that need to be monitored should never be hard coded into the program, they should be either stored in configuration files so they can be instantiated on the fly or be able to be added externally so a plug-in wizard type program can work with the Onsite Server. Also, the OSS would need to keep track of its current IP (Internet Protocol) address as well as previous addresses it had so it can re-register with the “Merton Server” when it detects a change in its IP address. This would allow the Onsite Server to always be in contact with the “Merton Server” so data can be requested at any time. Also, this would eliminate the need for the Onsite Server Computer to have a static IP address like our prototype system required. This is absolutely essential to a final system because it avoids having to develop a custom Onsite Server Program for each specific installation; one program could be used for all of the installations.

### 5.1.3 Installing the Merton Rule Monitoring System in Buildings

Our final subtask for establishing a working prototype system was the physical installation of the prototype system at The Big Yellow Self Storage Company. The installation experience was a valuable one and we learned lessons that are valuable to pass on to people wishing to pursue this project further:

- **Obtain electrical schematics from the building**

This is a very simple recommendation but it is very important. Before an installation, the building's wiring layout must be known, including the renewable energy sources diagrams. This would provide an insight into equipment which might be needed.

- **Visit the site early and often**

This was especially important to our project. Once we knew the wiring layout in the building, we arranged a visit to the site and viewed the wiring in person. This is very important because if the building is still under construction, like the Big Yellow Self Storage building was, the wiring or layout could change. Therefore, to ensure access to the latest schematics, site visits before the actual install dates are useful.

- **When to use a network hub in an install**

A network hub should be used to split an Ethernet connection only when data being sent through that hub must be sent to every device connected to the hub. This would allow a computer to analyze data being sent from all of the devices if needed.

- **When to use a network switch in an install**

A network switch would be used in most situations when installing networking equipment to split an Ethernet connection in a building. The reason for this is that the switch, unlike the network hub, does not split the network bandwidth between all the connected devices which does not slow down the network. Also, the switch is a smarter device when compared with a network hub. This means that the switch only forwards data to the device it is intended for. The switch is suitable for use in most installs.

- **Use PCMCIA or equivalent expansion cards instead of converters**

In our project, we used an Ethernet to USB converter to add a second Ethernet port to our Onsite Server Computer. In a final system install, it is recommended to use a PCMCIA expansion to add the second Ethernet port instead of the converter. The reason for this is that in a high speed network, like Gigabit network, the converter would not be able to handle the speed of this network and would act as a bottleneck to transfer speeds.

## **5.2 Monitoring Methods for Non-Electric Renewable Energy Sources**

In order to further the development of a renewable energy monitoring system, it is essential that more research be done in the fields relating to non-electric renewable energy sources. Electric sources provide a simple return of electric energy to the power system, but other sources provide energy in different ways. We have the following recommendations to further research into these areas.

- **Further research into ground source heat pumps & solar water heaters**

In order to further the monitoring of renewable energy usage more research must be done into the non-electric renewable energy sources in order to establish viable systems to monitor the different types. While we have shown that there is potential to monitor these systems by monitoring heat and flow rate, this is based on a theoretical system with only minor knowledge and some professional contact on the basis of the science behind it. The government should focus on the types and specifics of the heat pumps and solar water heaters they wish to use, and concentrate their research into the methods to monitor these for mass distribution. After speaking with Ice Energy, one of the companies who uses and monitors ground source heat pumps, they stated that it took two weeks of research by their research and development department in order to figure out the best ways to monitor their system. The systems can be monitored effectively, but more time must be spent studying these systems.

- **Additional monitoring device research**

In addition, while we focused on the products produced by RESOL, more research should be done into the monitoring devices that may be integrated into the system the three-project team has created. There are a variety of devices that exist to monitor temperature and liquid flows, therefore research must be done into these devices in order to make the system as efficient and cost effective as possible. The most important factor in these devices is that they can some way be linked into the computer placed on the site of the installation. In order for the data to be readily available to be

checked, it must first be able to be read into the on site computer. From there it can ideally be linked into the Geographical Information System (GIS), where the government will be able to gain access to this information to ensure that the Merton Rule is being complied to.

- **Biomass boiler analysis**

For biomass boilers, in order for a monitoring method to be developed, these systems need to be analyzed and a decision made about what factor actually makes them renewable. These factors are what need to be monitored. Since they perform like a regular boiler, their energy usage can be monitored in the same way. Research needs to be done into what can be used to quantify a value to monitor, and how this value will be entered into the system that is being used so they may be accessed in the same method that is being used to monitor other types of systems. This will allow for further monitoring of compliance with the Merton Rule.

### **5.3 Evaluating the Financial Viability of the Merton Rule**

We examined the financial benefits of the extended Merton Rule that the Mayor of London is implementing in London. In doing so, we suggest that the minimum requirement of this Merton Rule should continue to be increased so that there would be greater energy savings for London. We also recommend that the energy savings of commercial and residential buildings and the carbon savings of London be recalculated to remove the assumptions that we made.

- **Increase minimum requirement of the Merton Rule**

In order to increase the energy savings for London, the minimum requirement of the Merton Rule will gradually be increased in the future. However, the increase should take into account the capabilities of the industry of renewable technologies. For example, renewable technologies are costly and are several different technologies need to be installed to meet the Merton Rule requirement because of London's varying weather conditions. Therefore, the mayor of London must be mindful of what is feasible to ask the buildings of London to comply with because those buildings will need to invest in purchasing these technologies. Additionally, the mayor can encourage alternative supplementary ways of minimizing carbon emissions for their citizens using education. One simple example of such is educating London's citizens of the drastic amount of energy saved from simply using energy efficient light bulbs.

- **More research for more accurate calculations**

In developing the estimated energy savings of the commercial and residential buildings and carbon savings in London, we had to make simplifying assumptions. We assumed that the renewable technologies were only supplementing electrical energy and not being used to generate energy produced by gas and other fuels. Additionally, we assumed that energy consumption would remain the same as present day. As a result, we would recommend the numbers be recalculated to take this into account.

## 5.4 Guidelines for E Term Team

Over the course of the project, we were tasked with delegating all unfinished work to the E Term team for completion. The E Term team will be responsible for the following:

- **Ensure MRMS link to LOUIS**

MRMS to LOUIS Integration is where information from sensors being monitored by the OSS program in a Merton Rule building would be tagged into the Merton LOUIS GIS map. This would allow the users to be able to access the sensor data in a visual manner rather than retrieving the data using the RRA. Ultimately, this integration is required in the final system and it will be up to the E Term team to either implement or mock-up this interaction. There is some functionality in place to log incoming data from the OSS in the RRA, so the actual implementation should be possible for the E Term team to do.

- **Use the MapInfo program (LOUIS) to Tag buildings to a GIS Map**

Merton uses a program called MapInfo (<http://www.mapinfo.com>), to provide GIS functionality for their LOUIS system. The E Term team should research how MapInfo tags information to a GIS map and how they can integrate data logged by the RRA into the MapInfo map. They should also liaise with Gary Shaw from the Merton Council and Dr. Fabio Carrera from WPI, who is charge of the Merton LOUIS system.

- **Ensure the system can be understood by various interested parties**



There are several different special interest groups that need to be informed about our prototype system. Some of these groups include politicians, information technology professionals, and general government personnel. The third team will need to liaise with these relevant groups with specific emphasis for the differences between these groups. For example, a discussion of the system presented to information technology professionals will have a much greater focus on the technical and programming capabilities of our system.

- **Flag up an estimation of the costs entailed in fully developing our system**

At the end of the three project sequence, Mr. Hewitt will be looking for funding from the government departments and private investors to fully develop the system so it can be implemented throughout London. Therefore, he must have a basic estimation of the costs necessary in developing our prototype system. Some examples of these costs include hiring computer programmers to complete the development of the Merton Rule Monitoring System, a Merton server to run the On Site Server Program, and hiring engineers to develop methods of monitoring all the types of renewable technologies available in London. We recommend that the third team create a list of these costs

- **Creating the final presentation for the Investors**

Mr. Hewitt's final presentation to seek funding will inform potential investors of the scope of the prototype system, how the system will need to be developed further, and the expected costs in fully developing our system. This presentation will

also include a demonstration of RELIEF and how it will fit into the final system. The third team will work closely with Mr. Hewitt to the completeness of the presentation.

## 6.0 Conclusions

Climate change is expected to disrupt not only our living environment, but the entire ecosystem of the Earth. While climate change is considered to be a global issue, local communities can have an impact on reducing the emissions of greenhouse gasses. The London Borough of Merton, in an effort to combat global warming, has established the Merton Rule, which requires that all new commercial buildings must derive at least ten percent of their total power from renewable resources.

However, the Merton Rule is inconsequential without a means of enforcing it. Therefore, our project is the second in the series of three projects intended to build a system which will be used to monitor a building's compliance with the Merton Rule. Our project focused on the physical implementation of this monitoring system and the overall viability of the system for future development and implementation throughout Merton and possibly all of London. This was completed by fulfilling our three project objectives.

For the first objective, we developed a prototype system for monitoring the physical energy usage data from the buildings and transferring the data collected on site to a remote computer. Second, we explored the possibilities of expanding our system to monitor other renewable energy technologies that are viable in Merton. Finally, we presented the financial benefits of an expanded Merton Rule which would apply to all of London with a minimum requirement of twenty percent.

## 6.1 Establishing a Working Prototype System

Through the installation of a prototype system at The Big Yellow Self Storage Company, we learned that monitoring energy usage for compliance with the Merton Rule is viable on a building by building basis. The prototype system we developed, called the Merton Rule Monitoring System (MRMS), satisfied two requirements.

The first requirement was to gather energy data from a sensor or sensors located in a Merton Rule building. The sensor in The Big Yellow Self Storage Company was responsible for monitoring the photovoltaic panels located on the building's roof. We also developed a list of alternative sensors that can monitor electricity consumption and production which can be used in the final implementation of a system to enforce the Merton Rule. The second requirement that we fulfilled was that the system had to provide a way to forward data about the sensors it monitors to applications located offsite upon request.

Therefore, we were able to demonstrate that it is possible to monitor energy sources inside a building to ensure that the building is meeting its renewable energy requirements. Due to the fact that our system is specific to monitoring photovoltaic panels, we also performed research into methods of monitoring other renewable energy resources that could be used to satisfy the Merton Rule.

## **6.2 Monitoring Methods for Non-Electric Renewable Energy Sources**

While the prototype system that we created provides proof that energy generated from photovoltaic panels can be remotely monitored, this is not the only system that will need to be put in place. In order to monitor compliance with the Merton Rule, the government must be able to monitor all different types of renewable energy systems.

We were able to provide a detailed process which could be used to monitor another type of renewable energy source, solar thermal water heaters. In addition, we have shown that there is potential for monitoring of ground source heat pumps and biomass boilers. Therefore, additional renewable technologies can be incorporated into our monitoring system. In order for the monitoring of the Merton Rule to be successful, all energy types must be able to be incorporated into the overarching local information system. Only with this capability will the local government's environmental goals be able to be realized.

## **6.3 Evaluating the Financial Viability of the Merton Rule**

All of London will be seeing a form of the Merton Rule in the immediate future. The Mayor of London will be imposing an extended Merton Rule that will apply to the entire city of London with a minimum renewable energy requirement of twenty percent. This extended Merton Rule has benefits for London's commercial and residential buildings, as well as the local governments of London.

By requiring the commercial and residential buildings of London to supply twenty percent of their total energy consumption with renewable technologies, these buildings will save money in electricity bills. London's commercial sector is expected to save £2,640,000 and the residential sector is expected to save £3,740,000 annually. Additionally, when the extended Merton Rule is adopted in London, there are benefits for the local London governments as well. First, London would be able to avoid emitting unnecessary amounts of carbon. The annual carbon savings for London according to the trading value of carbon, Stern's social cost of carbon, and Defra's shadow price of carbon are £372,103, £719,059, and £528,720 respectively. Secondly, £102,400,000 worth of renewable technologies would need to be purchased in London to supply the rule. This expansion to the industry of renewable technologies means more jobs for the citizens of London and potentially lower costs for these renewable technologies.

However, this extended Merton Rule would be inconsequential without a means of enforcing it. Our system proposes a solution to this. With the proper funding from various government departments or private investors in London to fully develop our system, the local authority can ensure that all the buildings of London are in compliance with the rule.

## **6.4 Summary**

The overarching goal of our project was to determine if the Merton Rule is viable. Through the completion of our project specific objectives, we were able to provide evidence that the Merton Rule can be remotely monitored in a single building,

provide information on monitoring other forms of renewable technologies to extend the scope of our system, and determine the financial viability of where the Merton Rule is headed. The prototype system we installed in The Big Yellow Self Storage Company proves that a system can be developed to monitor such energy sources within a building and report information to a remote location. The research that we conducted on monitoring methods for non-electric renewable energy sources shows there is potential to monitor these sources and integrate them into our Merton Rule Monitoring System. Lastly, the research we did on the financial viability of an extended Merton Rule encourages the potential investors to fund our system so they can successfully monitor this rule as well as creating benefits for both the commercial and residential sectors of London. All of this information helps form a picture that shows that a system can and should be built to monitor the Merton Rule in its current and future revisions.

The acceptance of the Merton Rule, even on a borough wide level, would have a positive effect on climate change. Any borough or city that adopts the Merton Rule and thus reduces their carbon emissions will help to combat the effects of climate change due to greenhouse gasses. Proving the viability of the Merton Rule is a step towards widespread adoption, and thus, a reduction of carbon emissions, bringing us closer to reducing the human impacts that lead to climate change.

## Appendix A: London Borough of Merton Overview

### Merton History and Location

The London Borough of Merton is a region of London in the south west of the city (Figure 1). The London Borough of Merton was formed by the merging of the Municipal Borough of Mitcham, the Municipal Borough of Wimbledon and the Merton and Morden Urban District in 1965. (*History of Merton*)



**Figure A-1: Merton's Location**

(Bernard, R., Lessard, B., O'Keefe B., Scalabrini C, 2008)

### Organization and Budget

The London Borough of Merton is led by the Merton Council. The Council consists of five departments, which are illustrated in Figure A-2 below. First is the Chief Executive's Department. This department gives advice to the rest of the departments. Next is the Corporate Services Department that provides auditing, finance, and human resources services. Third are the Children, Schools, and Families Department which



aims to improve the lives of small children and young people. Fourth is the Community and Housing Department that provides community services and accommodation for people in need, and finally the Environment and Regeneration department which focuses on environmental issues and policies. The entire Merton Council has a 138.5 million pounds net annual budget for 2007-2008 (Budget 2007-2008).

The Department of Environment and Regeneration's mission is "to provide a coordinated approach to managing the public realm, as well as the regeneration of our town centres and neighbourhoods. It aims to maintain and improve the local environment and economy of the Borough by delivering quality services and by creating regeneration and partnership initiatives." The divisions of this department are focused on public protection and development, regeneration and leisure, and street scene and waste (Merton Council, 2007).

The regeneration and leisure division is further divided into teams. These teams are for regeneration partnerships, transport planning, plans and projects, property management, leisure and cultural greenspaces, and leisure and cultural development. The plans and projects team is the one who has the most direct focus on the Merton Rule. They are in charge of the various development plans and policies in Merton.

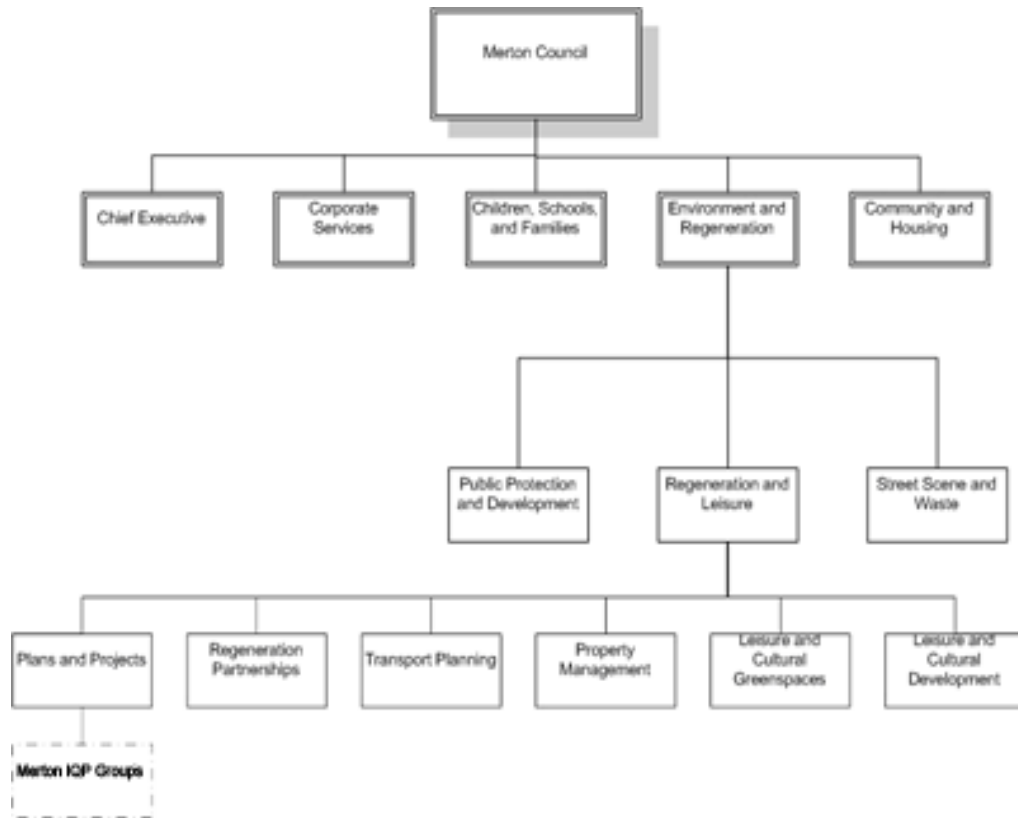

**Figure A-2: The Organization of Merton**

(Bernard, R. et al, 2008)

## Appendix B: Renewable Energy System Setups

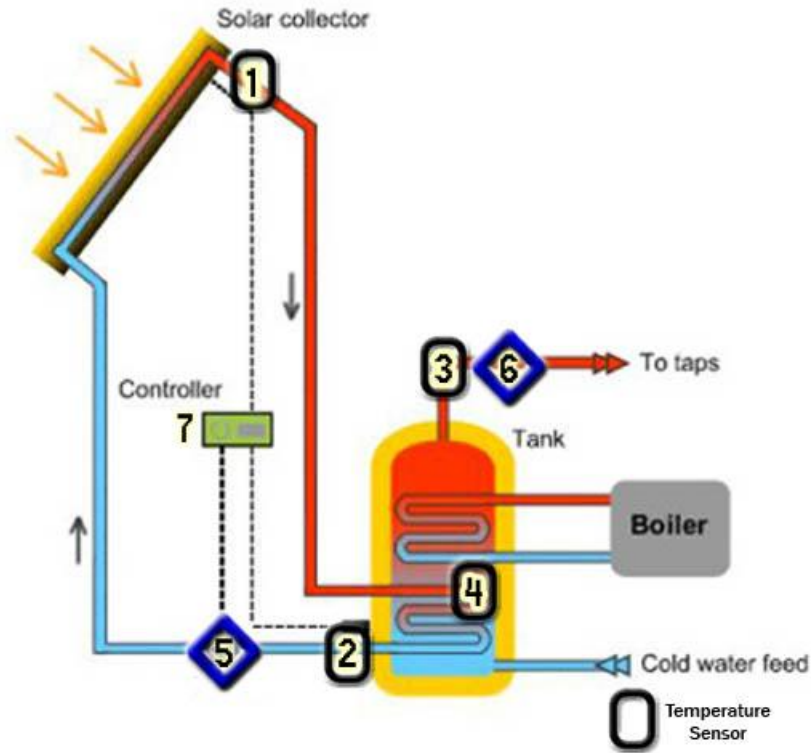

**Figure B-1: Solar Thermal Water Heater Monitoring**

(original image from <http://www.renewableenergycentre.co.uk/solar-heating>)

The solar thermal water heater works on the basis of using the energy from the sun to heat a liquid. Water is pumped up behind the solar panels or evacuated tubes, and is heated as it passes behind them. After it exits from behind the panels it is pumped through a water storage tank. Here it transfers its energy (heat) to the water,

replacing some of the work done by a boiler. From here the water can be distributed to the home.

In order to monitor this some laws of thermodynamics must be applied. The equation from energy for a flowing liquid is:

$$\text{Energy} = (\text{mass flow rate}) * (\text{Specific Heat of Fluid}) * (\text{Change in Temperature})$$

&

$$\text{Mass flow rate} = (\text{flow velocity}) * (\text{liquid density}) * (\text{Cross Sectional Area of Pipe})$$

The specific heat and liquid density are innate properties of the fluid being used, so they should be known. The cross sectional area of the pipe is also unchanging so it should be known as well. The items that need to be measured from the system are the temperature changes and the flow rate. In order to measure these there are a number of devices that will be need, and are denoted by number in the diagram.

**1:** (T1) This heat sensor will measure the liquid temperature after it has been heated by the solar panels.

**2:** (T2) This heat sensor will measure the liquid temperature before is heated by the solar panels

**3: (T3)** This heat sensor will measure the liquid temperature as it is being distributed through the home

**4: (T4)** This heat sensor will measure the liquid temperature as it is inside the boiler.

**5: (V1)** This flow rate sensor will measure the velocity of the fluid in order to calculate the mass flow rate

**6: (V2)** This flow rate sensor will measure the velocity of the fluid heading into the house

**7:** This control device will be the home for all the sensor collection and will monitor all of the data that they are collecting. If you desire this may be hooked up to a data-logging device, whose information can be read via computer.

These different sensors will allow us to calculate different energy values based on which temperature readings we use.

Mass Flow Rate of Panels =  $V1 * (\text{liquid density}) * (\text{Cross Sectional Area of Pipe})$

Mass Flow Rate of House =  $V2 * (\text{liquid density}) * (\text{Cross Sectional Area of Pipe})$

Energy Generation of Panels (E1) = (Mass Flow Rate of Panels) \* (Specific Heat of Fluid) \*  
(T1 - T2)

Energy Usage of Household (E2) = (Mass Flow Rate of House) \* (Specific Heat of Fluid) \*  
(T3 - T4)

% of Energy from Renewable Sources =  $E1 / (E1 + E2)$

In order for this information to be entered into our system, the controller at point 7 will need to be hooked up to some kind of data-logging device. From here this device can be linked directly into a computer, or it can be linked into the internet. The data can be read by a computer using a program or using a standard internet browser.

## Appendix C: Recommended Non-Electric Monitoring Sensors



### DeltaSol® BS – Standard Monitor Controller

The RESOL controller for standard solar thermal systems. DeltaSol® BS persuades by a clear operating concept and is equipped with the newly developed illuminated combined display with system monitoring. Flashing symbols for sensors, pumps and valves enable an immediate allocation of temperatures, temperature differences and active actuators. Adjustment and control of the solar system can be easily realized. An extension to the standard version of the controller DeltaSol® BS/3 with 2 standard relays is the version DeltaSol® BS/4 with 1 standard- and 1 semi-conductor relay for pump speed control of the solar pump.

- Illuminated system-monitoring-display
- Up to 4 temperature sensors Pt1000
- optionally: pump speed control, solar operating hours counter and thermostat function
- 2 basic systems are selectable
- Heat balancing, tube collector function
- Function control
- Housing in outstanding design and easy user friendly operation



### Datalogger DL1 – Standard Datalogging Device

Larger data packets (e.g. measuring- and balance values of the solar system) can be recorded self-sustaining over longer periods by this additional model. The internal memory can be configured and read-out by the RESOL ServiceCenter-Software or by

integrated web interface with standard Internet browser. The datalogger is equipped with a 2 MB Flash memory and is appropriated for all controllers with RESOL VBus® . The datalogger can be connected directly to a PC or modem for remote control and thus enables a comfortable system monitoring for profit control or for extended diagnostics of fault localization

- Visualization of system states (system monitoring)
- Profit control
- more simple malfunction diagnostics
- Simple configuration by integrated web interface for standard Internet browser or RESOL ServiceCenter-Software
- Integrated web interface
- Export function for further data processing in spreadsheet calculation programs
- Direct connection of PC or modem for remote inquiry
- Incl. RESOL Service Center software



#### **Pump station FlowCon A - DeltaSol® AX – Standard Pump Station**

Standard single-line solar pump station for mounting into a solar return flow. The pump station is either available with the controller RESOL DeltaSol® AX. The most important hydraulic components for operation of a solar system are already mounted for an easy and quick installation. Please see pages 8 and 10 for further information about the controllers.

- integrated controller: DeltaSol® AX
- solar thermal pump WILO Star ST20/ 6 or ST20/7 (surcharge)
- manual vent
- flowmeter
- security bracket with security valve and manometer



- wall mounting with screws and dowels
- filling and flushing connections
- heat insulation
- pre-assembled



### **RESOL V40 – Standard flow monitor**

The RESOL V40 is a measuring instrument with contactor for recording of water flow or water-glycol-mixtures. It is ready for use in the RESOL calorimeters. After flow of a specific volume, the V40 sends an impulse to the calorimeter. The used heat amount is calculated by these impulses, the temperature difference and pre-defined parameters (glycol type, concentration, heat capacity etc.) The V40 is available for different connection diameters and different nominal flow amounts. They differ in layout, but have the same functions. Delivery including connection screw.

Note:

Version 1 is appropriated for horizontal as well as for vertical mounting. Version 2 is only for horizontal mounting.



### **Temperature Sensors**

The temperature sensors come in various sizes and for various purposes. They are sold for different temperature ranges, as well as different interfaces. They can be purchased for Flat Surfaces, Cylindrical Surfaces, and for high immersion. They also have a varied price range.



## Appendix D: Recommended Electric Monitoring Sensors

### Single Phase Power Systems:

1. Ted Sensor 1000

<http://www.theenergydetective.com/store/>



Accuracy: +/- 2%

Cost: \$185

Maximum Current: 100 Amps

Phase Characteristic: Single

Data Transfer: USB through Ted Foot Prints

Data Format: Excel

Data Content: kWh, Dollars and Voltage

Installation Information: Connected the 2 Current Transformers (CT) onto Phase A and Phase B as shown in the diagram below. More information about the installation will be provided when purchasing the product.

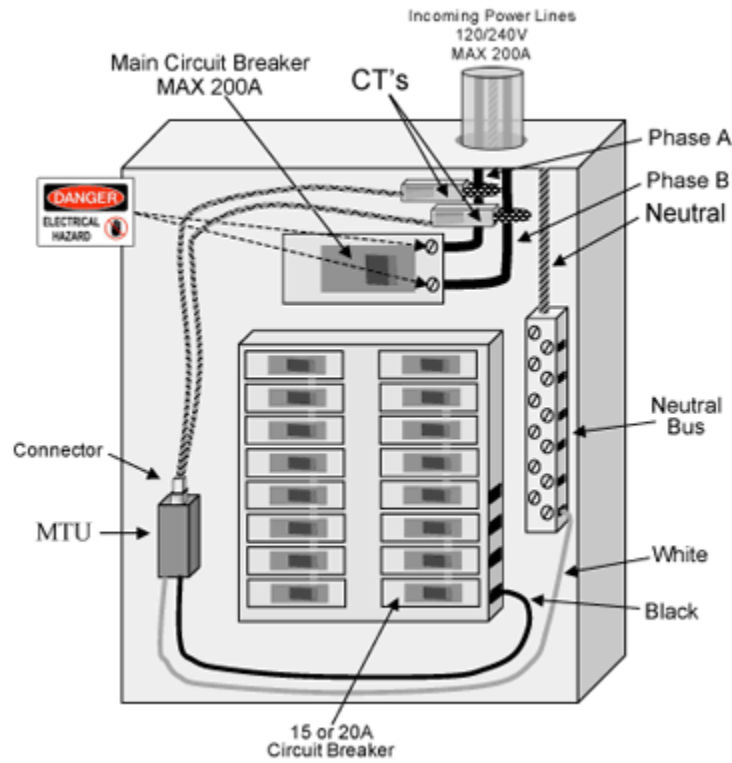

2. Meteo Control Sensor (Safer`Sun profi\_en)

<http://www.meteocontrol.de/cms/db/index.php?pageID=65>

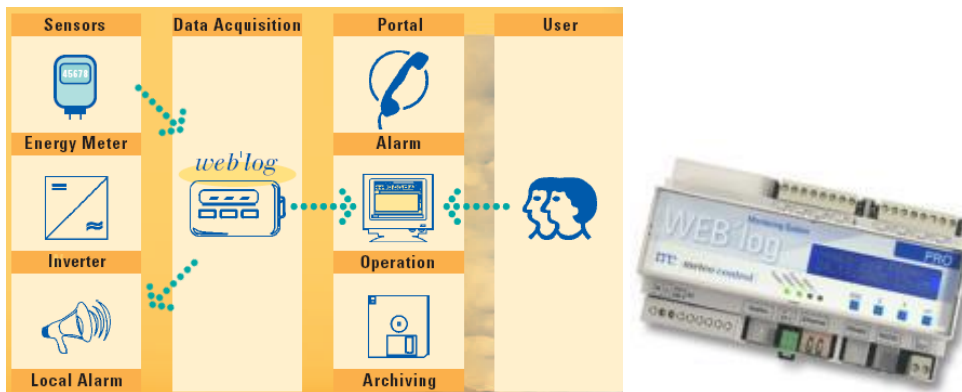

Accuracy: State Approval Number: ptb20.15.99.85

Cost: \$695

Maximum Current: 20 amps

Phase Characteristic: Single



Data Transfer: FTP Server through Ethernet cables (Cat5e)

FTP Connection

Username: admin

Password: admin

FTP Browser:

Password: est02

Data Format: Text

Data Content: kWh

Installation Information: Refer to their instructions

### 3. Powertek ISW8001

<http://www.powertekuk.com/pwr1ph.htm>



Accuracy:  $\pm 0.2\%$

Cost: \$790

Maximum Current: 16Arms or 22 Amp peak

Phase Characteristic: Single

Data Transfer: USB, RS232

Data Format: Ascii

Data Content: Amps, Volts, Watts

Installation Information: Refer to Appendix F

### Three Phase Power Systems:

#### 1. Wattson Sensors

<http://www.diykyoto.com/>

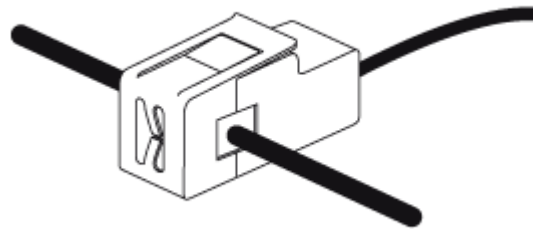

Accuracy: +/- 2%

Cost: \$390

Maximum Current: 50 Amps

Phase Characteristic: single phase, two phase, and three phase

Data Transfer: USB

Data Format: Accessable Database after 5/1/2008

Data Content: kWh, Watts, Money Spent

Installation Information:

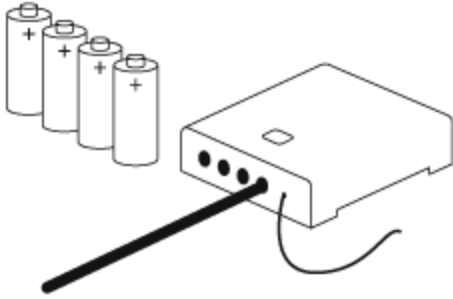

**STEP 1  
INSERT THE BATTERIES INTO THE TRANSMITTER**

The transmitter takes 4 AA batteries. Make sure the end of the battery marked + goes in the end of the tray marked + (making sure the aerial on the transmitter is extended). Then plug in the sensor lead.

**STEP 2  
ATTACH THE SENSOR CLIP**

The sensor clip can be attached to either of the 2 cables running from the electricity meter to the fusebox.

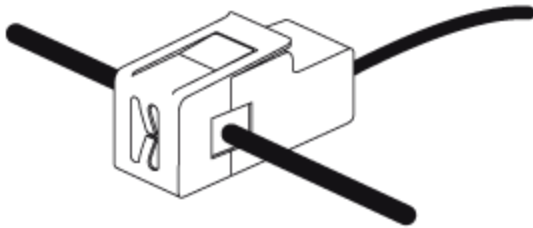

If your meter is a long way from your fusebox (as you might find in a block of flats), connect the clip to the cable where it enters the fusebox, so that the transmitter is as near as possible to where you will be using the wattson display. Simply undo the clip and fit it around the cable. Make sure the clip top is firm and secure in the clip base.

**STEP 3  
PLACE THE TRANSMITTER**

The transmitter can go on the wall next to the meter (or fusebox), or on a nearby shelf if there is one. If your meter is in a meter box, the transmitter may work best if it's outside of it. If the sensor lead does not reach outside, it will work from inside the box but the range may not be as good.

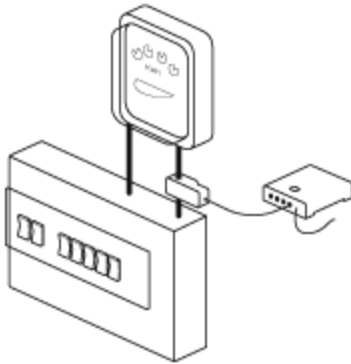

More instructions will be provided in the manual

## 2. Meteo Control Sensor (Safer`Sun profi\_en)

<http://www.meteocontrol.de/cms/db/index.php?pageID=65>

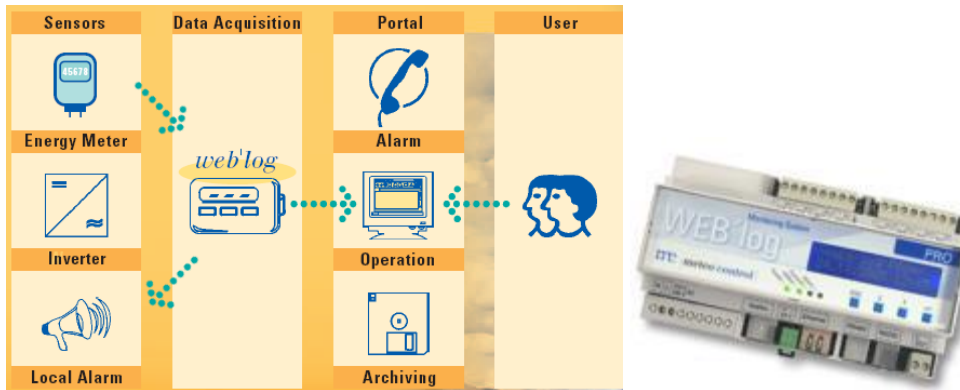

Accuracy: State Approval Number: ptb20.15.99.85

Cost: \$861

Maximum Current: 65 amps

Phase Characteristic: Three



Data Transfer: FTP Server through Ethernet cables (Cat5e)

FTP Connection

Username: admin

Password: admin

FTP Browser:

Password: est02

Data Format: Text

Data Content: kWh

Installation Information: Refer to their instructions

### 3. Powertek ISW8300

<http://www.powertekuk.com/8300pkuk.pdf>



Accuracy:  $\pm 0.2\%$

Cost: \$1600

Maximum Current: 15 Amps or 500 Amps with external transformer

Phase Characteristic: Three

Data Transfer: USB, RS232

Data Format: Ascii

Data Content: Amps, Volts, Watts

Installation Information: Refer to Appendix F



## Appendix E: Understanding Electricity at Commercial Grids

Here is the system diagram of how a building is getting electrical power:

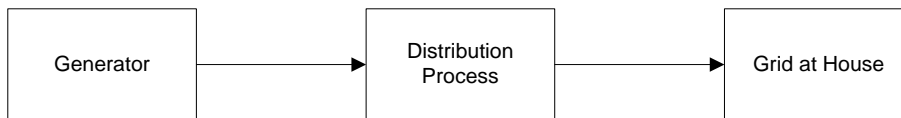

**Figure E-1: Electrical System Diagram**

There is some kind of mechanical force turning a generator. This generator is attached to dynamos or something equivalent to convert mechanical energy to electrical energy.

This energy is then sent over transmission lines in the distribution process and eventually reaches the power grid at residential homes.

In terms of circuitry, the grid can be modeled by an AC source as shown on the figure 2 below. For simplicity sake, this appendix will only discuss single phase.



**Figure E-2: Voltage Source with Load**

Figure 2 also shows R1. R1 represents a combination of electrical loads caused by household appliances. Depending on the load, the grid will source a different current.

However, the voltage across the load(s) is always the same.

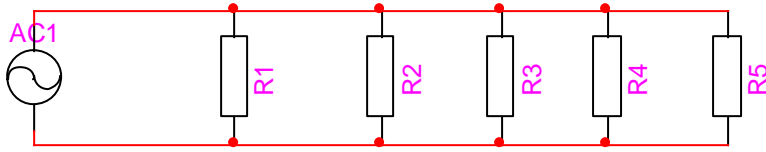

**Figure E-3: Voltage Source with Loads**

Figure 3, shows 5 different loads connected to the grid. Because loads are always connected in parallel to each other, the voltage across each load is again, the same.

The Grid modeled by the AC source in a typical European home is modeled by this equation:

$$V_{AC1} = 339.4 \sin(2\pi 50t)$$

According to Ohm's Law, the amount of current that the loads draw is modeled by this equation:

$$i = \frac{V_{AC1}}{\text{Total Load}}$$

Total Load is shown as R1 on Figure 2. However to compute total load for figure 3, this equation is used:

$$\text{Total Load} = \frac{1}{\frac{1}{R_1} + \frac{1}{R_2} + \frac{1}{R_3} + \frac{1}{R_4} + \frac{1}{R_5}}$$

To make sense of this equation, Total Load decreases as more loads are connected in parallel. If the Total Load decreases, then the current drawn from the source increases.

Therefore, the more appliances one connects to the grid, the more current the grid outputs.

Figure 4 shows how the current is flowing through the loads:

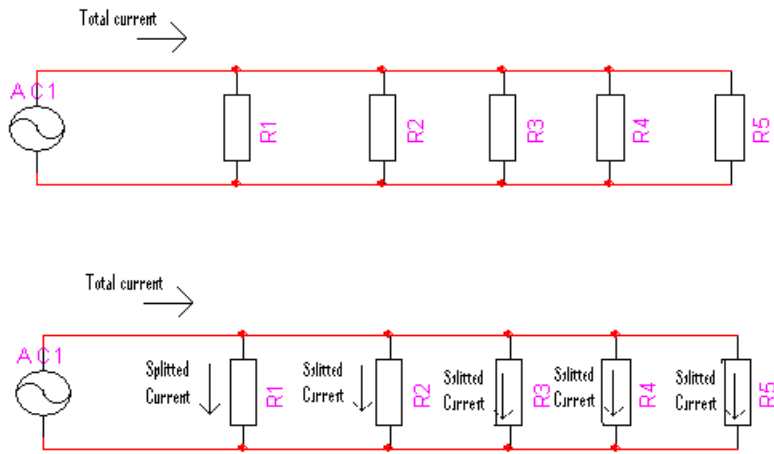

**Figure E-4: Voltage Source Showing Current Flowing through the Loads**

Since the source is AC, at certain times, current will flow the other way as shown on figure 5:

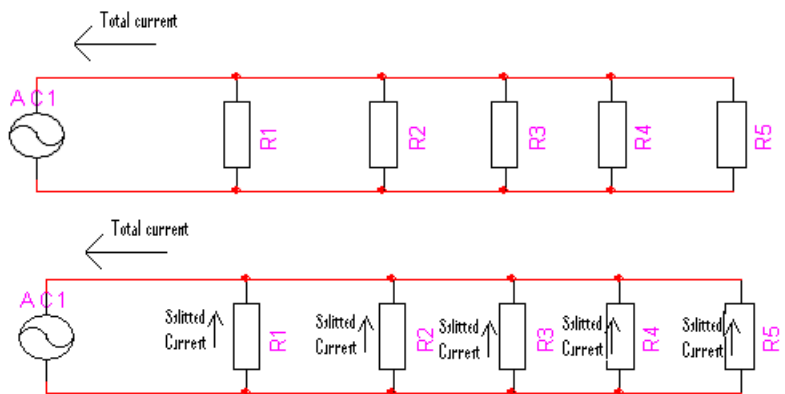

**Figure E-5: Voltage Source Showing Current Flowing through the Loads**

So both figure 4 and figure 5 shows a large current (Total Current) coming from the AC source and that current is split amongst the loads.

## Money:

One can safely say that the amount of money charged for energy usage depends on the amount of current used over a period of time.

We now introduce two new variables: Energy and Power

Power is computed by multiplying voltage and total current:

$$P = I_{\text{total}} * V_{\text{AC1}}$$

Power is in units of watts, which is the rate at which energy is being used up.

To get energy, which is in kilowatt-hours, one needs to multiply the duration of time by the average power consumed in that time:

$$\text{Energy} = \text{Average Power} * \text{time duration}$$

The most common mathematical expression for energy is:

$$E = \int_{t_1}^{t_2} P dt$$

$t_1$  to  $t_2$  is the span of time that this equation applies to. For Power Plants, this range of time is usually duration of 1 month, as most people get a bill each month.

In England, energy is charged at a rate of \$0.32 per kilowatt-hour. So if one knows how many kilowatt hour he's using, then he can know how much he needs to pay the electric company.

## Appendix F: How to Install Power Sensors in a Single Phase System

As stated in Appendix G, we found devices that can measure voltage and current at the same time and derive kilowatt hour for us. These sensors include Ted, and the Wattson sensors. This section will cover how to install such devices for a single phase power system.

Currently, the Big Yellow Building has solar panels in support of the power grid. The solar panel circuitry contains an inverter which allows the current from the solar panels to be alternating and in phase with the current coming from the grid. At this point in time, the city power supplier would not release any information, so 2 sensors are needed to track the non-renewable energy source and the renewable energy source.

This is what the system looks like without the sensors:

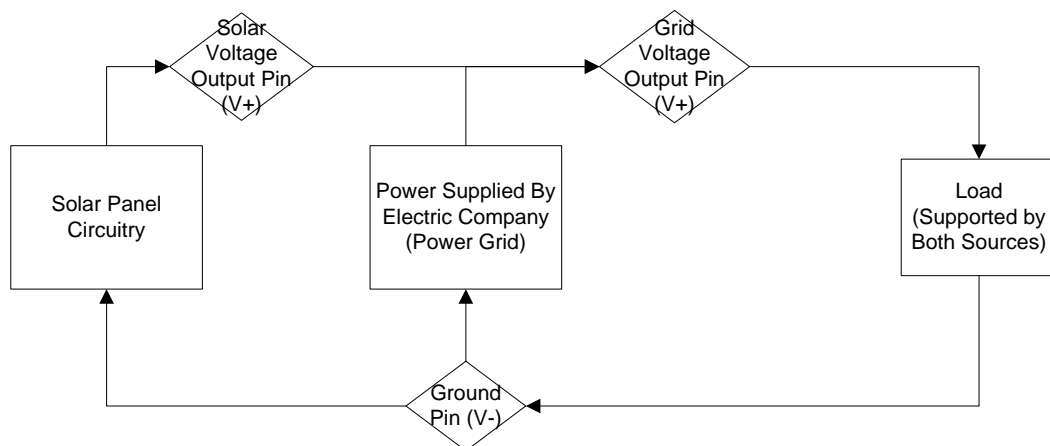

**Figure F-1: Electrical System Diagram**

The arrows represent the flow of current at an instance in time.

The figure above shows that current is flowing out of the Solar Panel Circuitry and the Power Grid and through the load supplying the load with electricity.

Next we need to install a sensor so that we can measure the current that is coming out of the Solar Panel Circuitry ( $i_1$ ) and the voltage drop ( $V_s$ ) across the Solar Panel Circuitry and a 2<sup>nd</sup> sensor to measure the total current ( $i_T$ ) from the solar panel circuitry and the grid and the voltage drop ( $V_t$ ) across the grid.

The system will look like this after sensors are installed:

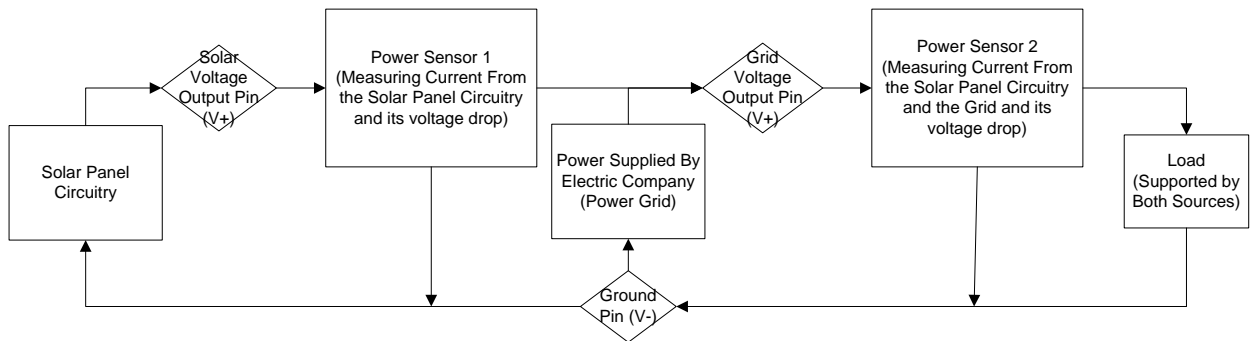

**Figure F-2: Electrical System Diagram with Power Sensors Installed**

Note that each power sensor should have at least 3 pins (connections).

For illustration purposes the following image shows a house that has a similar setup:

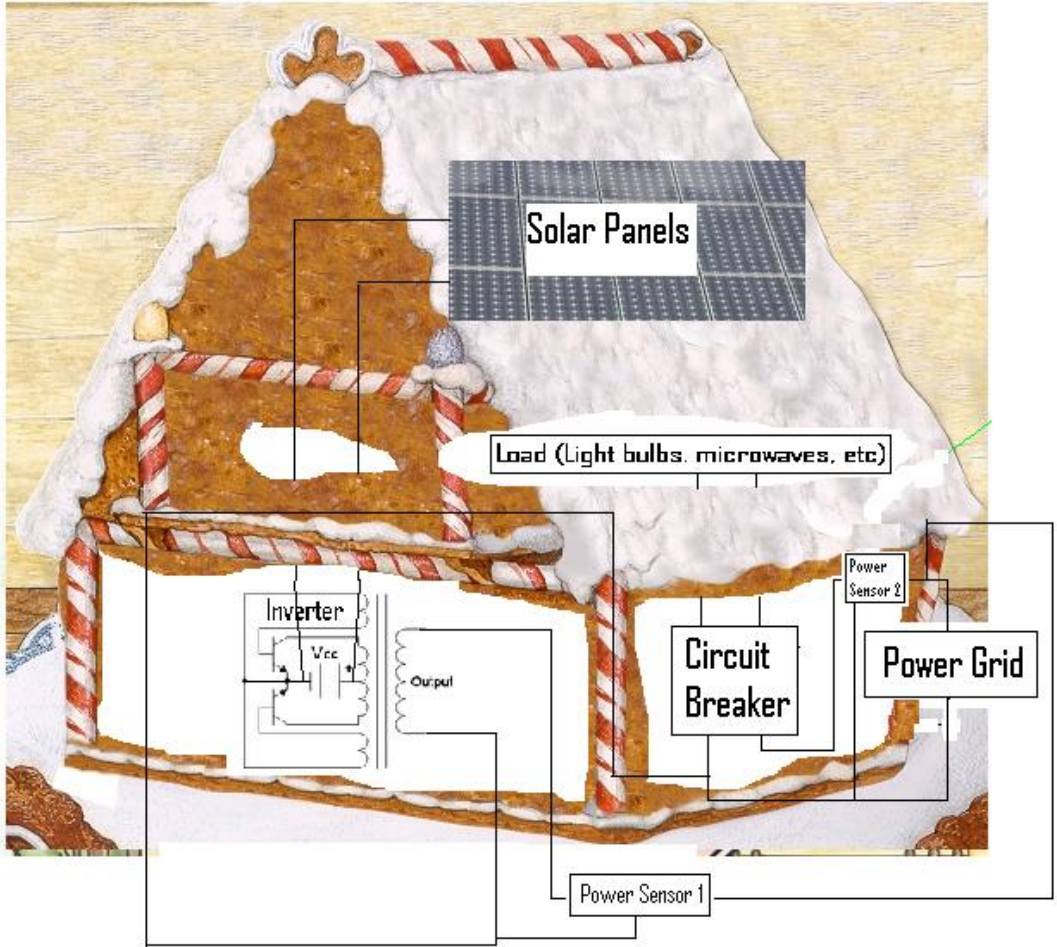

**Figure F-3: Electrical Components in a Building**

**How to Make Sense of the Data:**

Note that this process is already done for us by the device. Shown here are some computations that are done inside the device.

The devices use the equation to find power:

$$\text{Power} = \text{Voltage} * \text{Current}$$

From power sensor 1, we get  $i_1$  and  $V_s$ , which is the current from the Solar Panel circuitry and the voltage drop across the Solar Panel Circuitry respectively.

From these two values the device can compute power (P1):

$$P1 = i_1 * V_s$$

From P1, the device can compute energy (E1) in kilowatt hour by integrating power in respect to time:

$$E1 = \int_{t1}^{t2} P1 dt$$

From power sensor 2, we get  $i_t$  and  $V_t$ , which is the total current from the Solar Panel circuitry with the grid and the voltage drop across the grid respectively.

From these two values the device can compute power (P2):

$$P2 = i_t * V_t$$

From P2, the device can compute energy (Et) in kilowatt hour by integrating power in respect to time:

$$Et = \int_{t1}^{t2} P2 dt$$

The output of the devices gives us E1 and Et.

The percent of renewable energy is given by this equation:

$$\% \text{ of Renewable Energy} = \frac{E1}{Et} * 100$$



According to the Merton Rule, % of Renewable Energy should be greater than 10.

## **Appendix G: How to Install Current sensors in a Single Phase System**

The method presented here simplifies the hardware as much as possible for a single phase power system. This simplification allows for cheaper hardware with a cost to accuracy due to only using the current sensor. We have found devices that can measure current and voltage at the same time and the methods of installing them will be discussed in Appendix F and Appendix D.

Currently, the Big Yellow Building has solar panels in support of the power grid. The solar panel circuitry contains an inverter which allows the current from the solar panels to be alternating and in phase with the current coming from the grid. At this point in time, the city power supplier would not release any information, so 2 sensors are needed to track the non-renewable energy source and the renewable energy source. Note that this system is a single phase power system.

This is what the system looks like without the sensors:

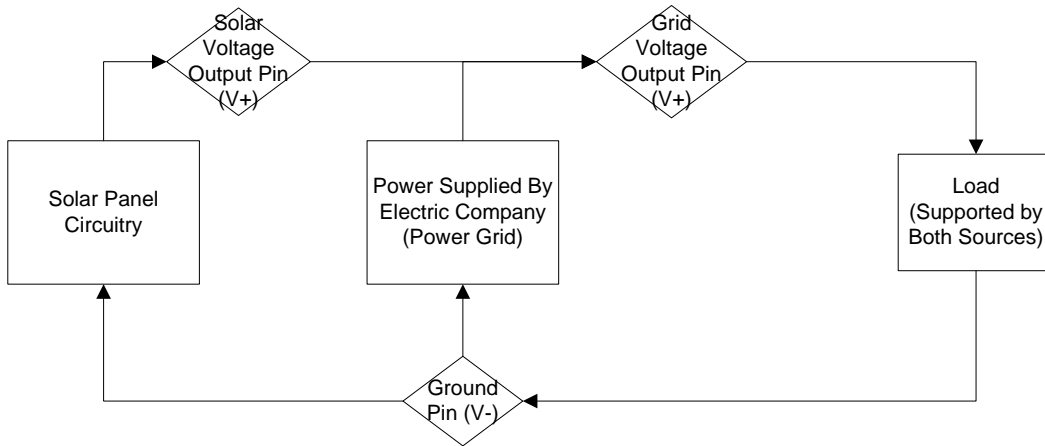

**Figure G-1: Electrical System Diagram**

The arrows represent the flow of current at an instance in time.

The figure above shows that current is flowing out of the Solar Panel Circuitry and the Power Grid and through the load supplying the load with electricity.

Next we need to measure the current that is coming out of the Solar Panel Circuitry ( $i_1$ ) and the total current ( $i_T$ ) with 2 current sensors.

The system will look like this after sensors are installed:

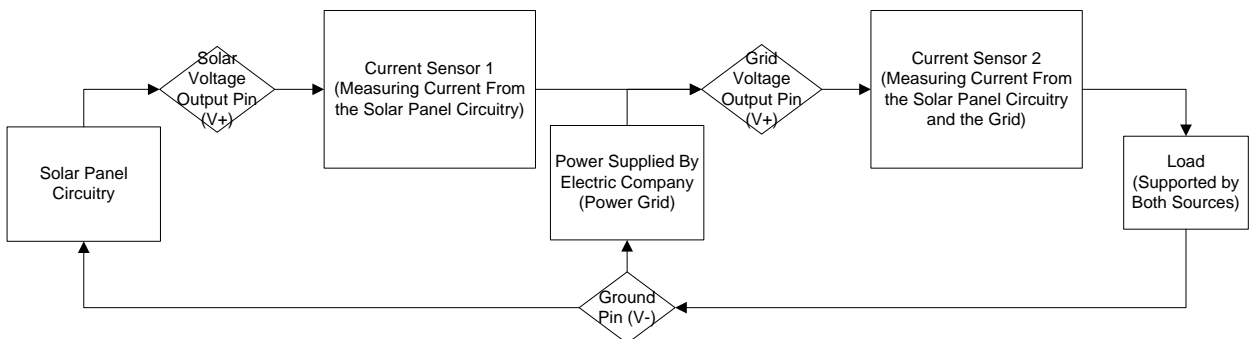

**Figure G-2: Electrical System Diagram and Installed Sensors**

For illustration purposes the following image shows a house that has a similar setup:

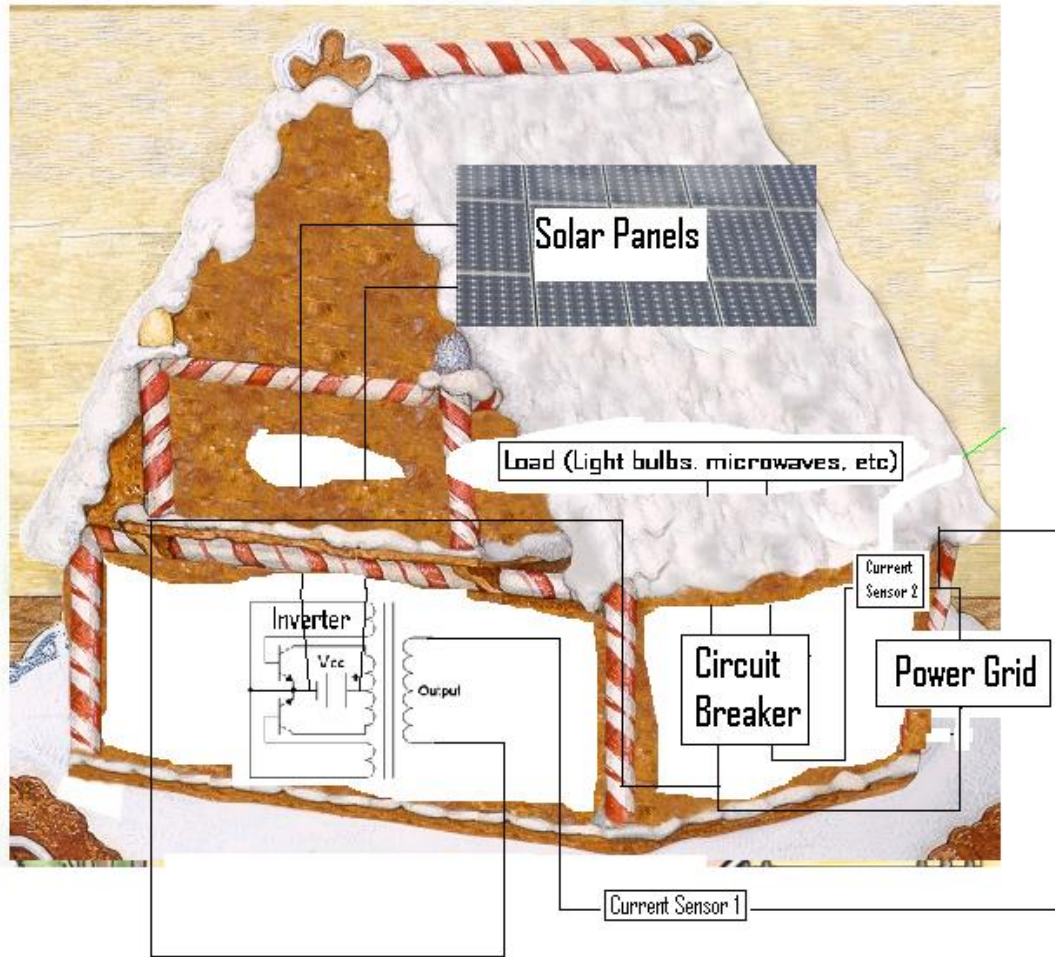

**Figure G-3: Electrical Components of a Building**

Now, referring back to figure 2, the current flowing out of the Solar Panel Circuitry will flow through Current Sensor 1, and Current Sensor 1 will detect its value. And the current flowing out of the Solar Panel Circuitry and the Power Grid will flow through Current Sensor 2. The difference between those 2 values is  $i_2 = i_T - i_1$ , which is the current flowing out of the Power Grid.

$i_1$  = current from Solar Panel

$i_2$  = current from the Power Grid

The values of  $i_1$  and  $i_2$  are logged on a computer running MrHomer. (Technically  $i_T$  is logged first due to easy installation, but the difference is calculated as soon as MrHomer reads that value.)

### How to Make Sense of the Data:

To make sense of the data we first use the equation to find average power (we do this twice, once for  $i_1$  and another for  $i_2$ ):

Average Power = Average Voltage \* Average Current

First we investigate in the calculation of voltage:

The system power source can be seen as one AC voltage source described by the equation:  $v(t) = 339.4 \sin(2\pi 50t)$

This equation describes UK voltage source at 240Vrms running at 50hz. 240Vrms means the amplitude of the wave  $V_{peak} = 240 * \sqrt{2} = 339.4$ .

The voltage across the load average out to be 216.1V. (For More Mathematical Details Refer to the Average Voltage Calculation Section)

Next we investigate on calculating average current:

Since this system is alternating current, the sensors will at times report negative values for current. Therefore, we first take the absolute value of all the current values that are stored in the computer running MrHomer. Next, we take the average of all the values of

current by adding them up and dividing that by the number of values. The result is Average Current.

Now that we know Average Voltage and Average Current, we know Average Power.

From Average Power, we calculate how much energy is used from the solar cells and the power grid by this equation: Energy = Average Power \* Duration of Time

Remember that we have 2 different sets of current values (one for solar cell and one for grid). Therefore, we have 2 different values for energy as well. This means we know how much energy was used by the Photovoltaic Cells (E1) and how much energy was used by the power grid (E2). These two values are calculated by MrHomer and are sent to the City Database upon request.

In practice, it might be more accurate to calculate the total energy from the solar cells and the power grid using  $i_T$  instead of  $i_2$  and then subtracting that value from the energy of from the solar cells. The reason is that in order to get an accurate value for  $i_2$ , the values of  $i_T$  and  $i_1$  used to calculate  $i_2$  must be the same instance of measurement.

Whereas the approach of total energy being calculated first gives more room for timing errors.

The percent of renewable energy is given by this equation:

$$\% \text{ of Renewable Energy} = \frac{E1}{E1 + E2} * 100$$

According to the Merton Rule, % of Renewable Energy should be greater than 10.

**Average Voltage Calculation (For Documentation Purposes):**

As stated the system power source can be seen as one AC voltage source described by

the equation:  $v(t) = 339.4 \sin(2\pi 50t)$

This is the plot of this equation:

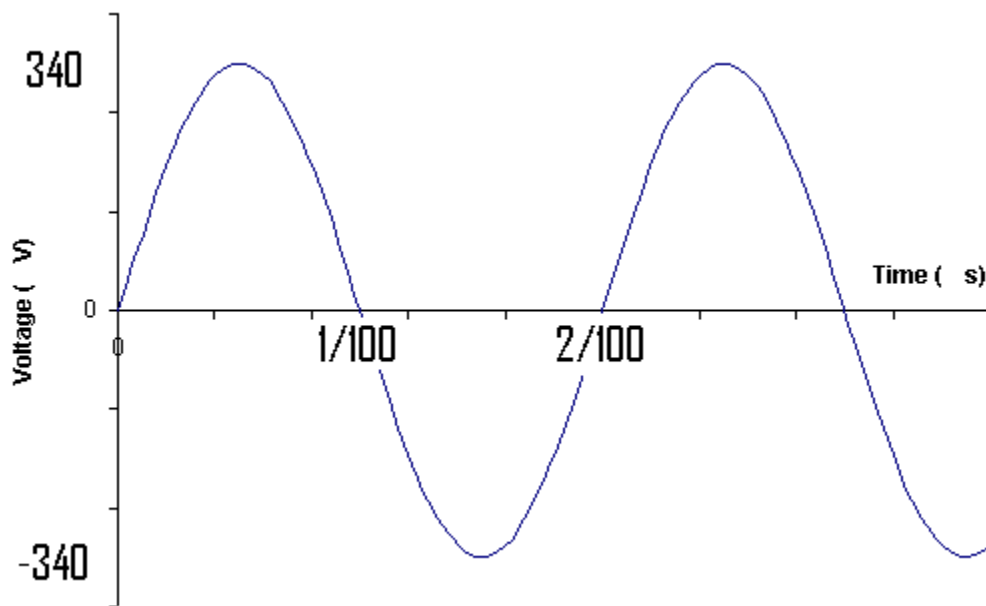

**Figure G-4: Voltage of AC Waveform for Power Grids**

Next we take the absolute value of  $v(t)$  giving us this graph:

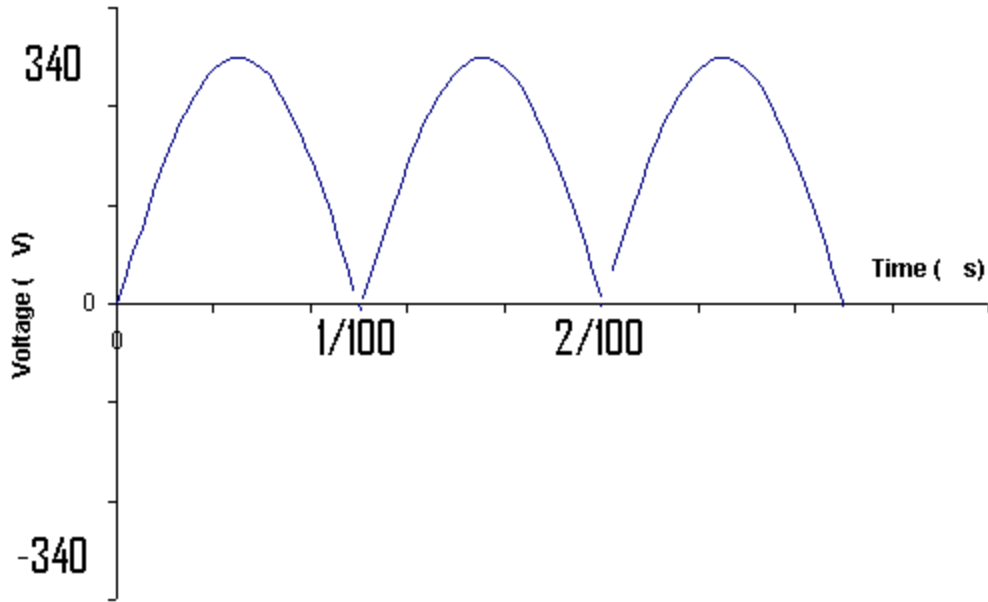

**Figure G-5: Absolute Value of Voltage of AC Waveform for Power Grids**

The reason that we need to take the absolute value for voltage is the same reason we took the absolute value for current.

The goal is to get the average voltage so we apply the average function on this graph:

$$y_{\text{ave}} = \frac{\int_a^b f(x) dx}{b - a}$$

Therefore:

$$\text{Average Voltage} = \int_{t=0}^{t=1/100} \frac{v(t)}{\frac{1}{100} - 0} dt = \int_{t=0}^{t=1/100} 339.4 \frac{\sin(2\pi 50t)}{\frac{1}{100} - 0} dt = 216$$

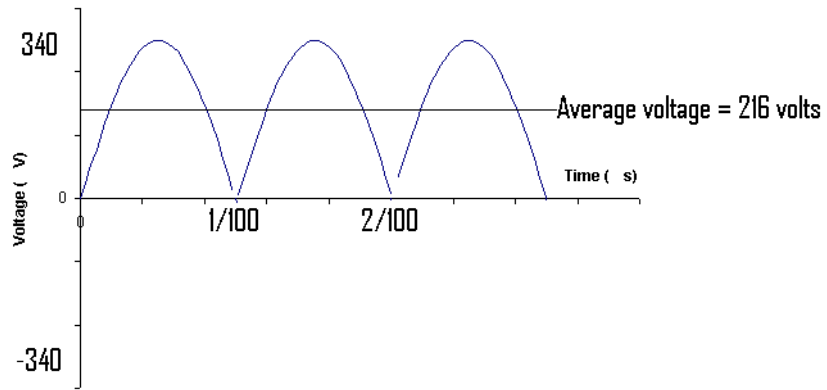



## Appendix H: Dealing with Three Phase Systems

### Understanding Three Phase Systems:

The power output from grid is a sinusoid. In some buildings, the power grid outputs 3 sinusoid waveforms with 120 degree phase difference on 3 different wires. This type of output is called three phase power. Some advantages to a 3 phase power system with respect to a single phase power system are: 1) It causes less vibration to the electric generator, and 2) It allows electric motors to rotate easier.

The circuit diagram below shows a typical three phase system.

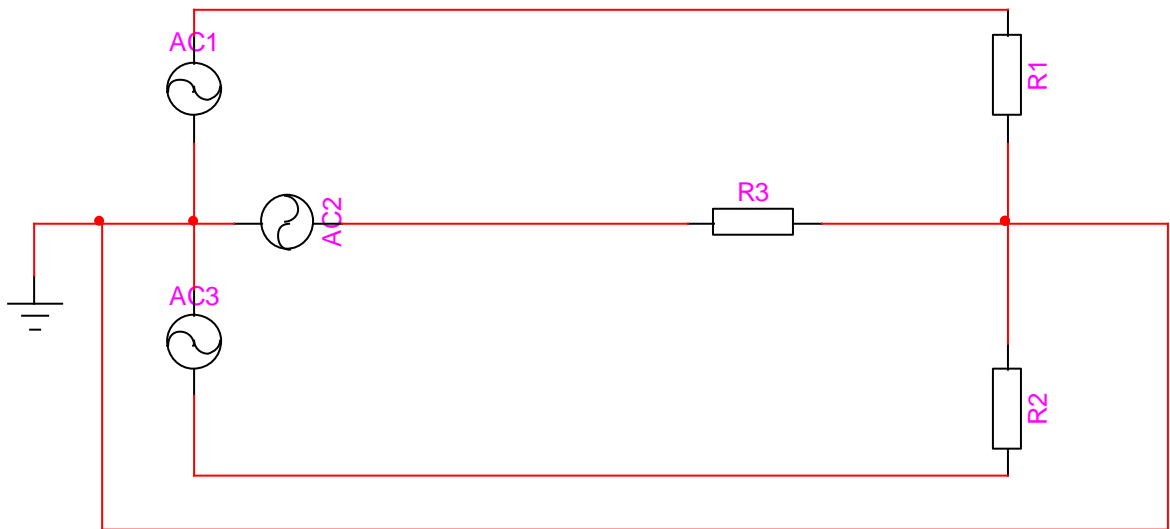

**Figure H-1: Three Voltage Sources with Their Loads**

The three sources in Figure 1, AC1, AC2, and AC3 are three different sinusoids. For the case of European buildings:

$$V_{AC1} = 339.4 \sin(2\pi 50t)$$

$$V_{AC2} = 339.4 \sin(2\pi 50t + \frac{2\pi}{3})$$

$$V_{AC3} = 339.4 \sin(2\pi 50t + \frac{4\pi}{3})$$

The three loads in the diagram R1, R2, and R3 represent typical appliances to be plugged into the wall such as light bulbs, computers, microwaves, etc.

Figure 1 can be seen as three different sources in three different single phase circuits as shown on figure 2:

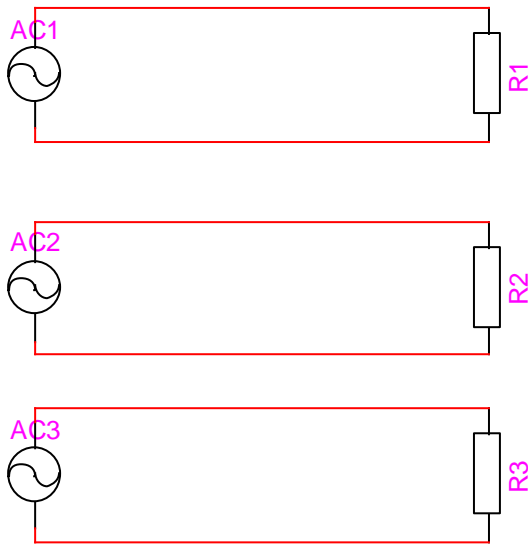
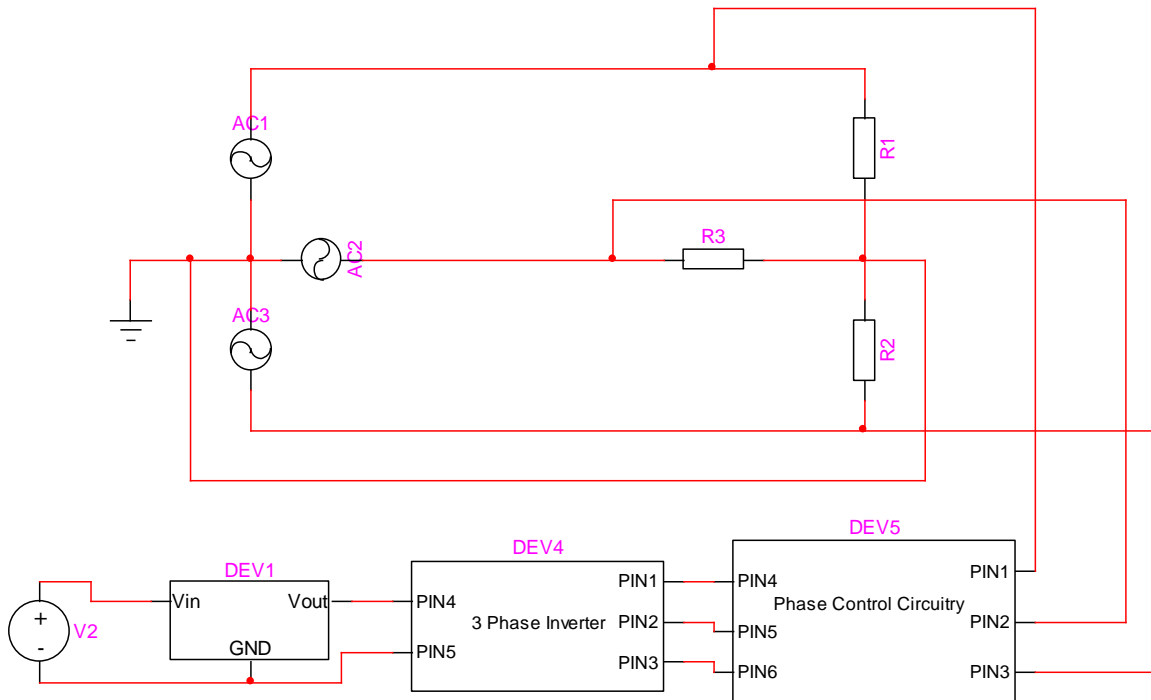

**Figure H-2: Equivalent Three Phase Circuit**

Figure 2 shows an equivalent circuit diagram to Figure 1.

Three Phase Inverters:

Next, we support the grid with solar power as shown in figure 3.



**Figure H-3: Three Voltage Sources with Their Loads and Solar Panels with Circuitry**

Figure 3 shows what the circuit would look like if there are inverters attached to a 3 phase power grid. An inverter is a device that turns DC waveforms into AC.

Shown on Figure 3 is a DC power source labeled V2 which represents the solar panels. Attached to this source is DEV1 which is a voltage regulator to bring the voltage up. And attached to that is DEV4 and DEV5 to turn the DC source to AC and make it in phase with the voltage outputs from the grid. The grid would not be getting power efficiently (if at all) if any of these components are missing.

Once the voltages from the inverters are in phase with the grid, they can be attached to the loads in the grid, supplying the loads with power.

## Monitoring Three Phase Systems with the PVs:

Recall from Appendix G that we found devices that can measure voltage and current at the same time. And as seen on Figure 2, since the sources are treated and used as separate entities, we need 3 of such devices to monitor a 3 phase power grid. Also, recall that there are solar panels that are adding power to the grid.

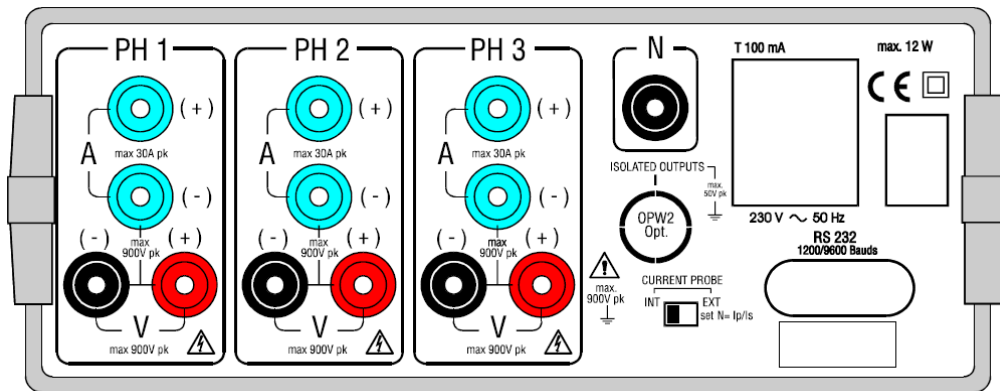

**Figure H-4: Powertek ISW8300**

Figure 4 shows a device that has 3 power sensors (1 for monitoring each phase). This device is the Powertek 8300. For the purpose of monitoring the grid and the PVs, the V+

pin of figure 4 is connected to the A+ pin of figure 4 (for all 3 sensors). This connection is shown as PIN2 on figure 5.

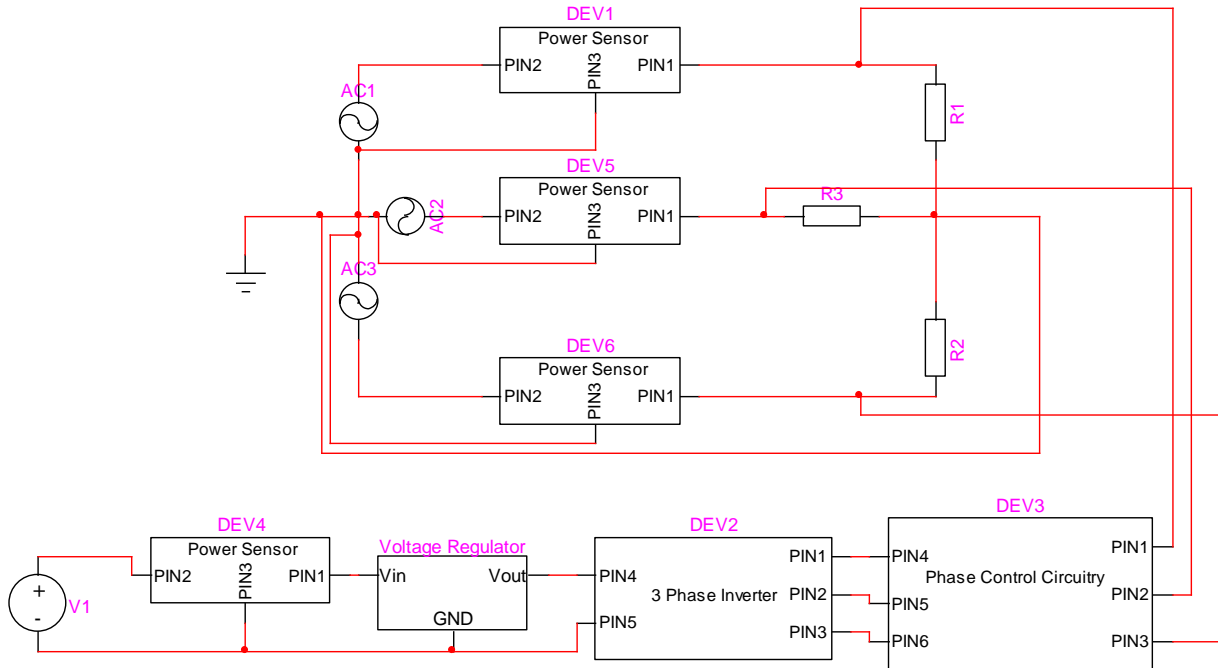
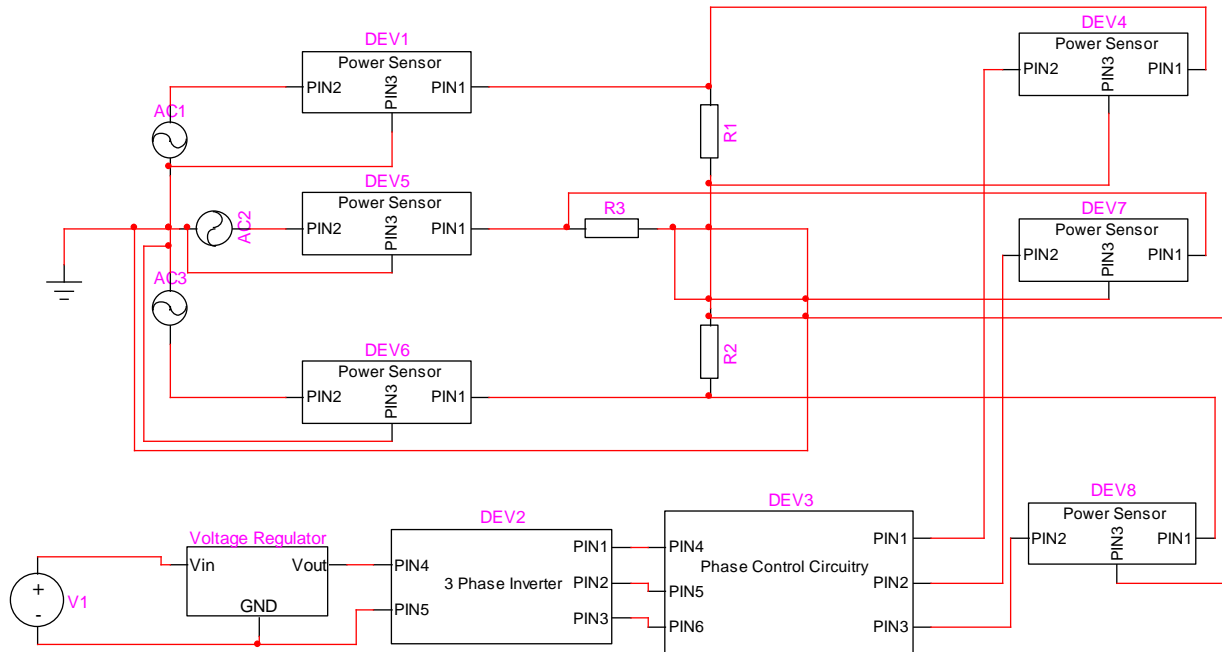

**Figure H-5: PV Direct Three Voltage Sources with Their Loads and Solar Panels with Circuitry and Power Meters**

Figure 5 assumes that we can monitor the solar panels directly so we only need 4 power sensors. For the grid we installed 3 power sensors, one on each AC source on figure 5. And we just need another power sensor to measure V1, the solar panel source.

For the case that we cannot access the solar panels directly, we have to measure power from the three phase inverters. The installation of the 6 power sensors are shown in

Figure 6. Powertek 8300 provides us with 3 power sensors per device so we only need to get two of Powertk 8300.



**Figure H-6: Inverters Direct Three Voltage Sources with Their Loads and Solar Panels with Circuitry and Power Meters**

This figure shows how the 6 power sensors (2 Powertek 8300 Devices) are installed into the grid and the inverter outputs.

Here is the model of the actual installation:

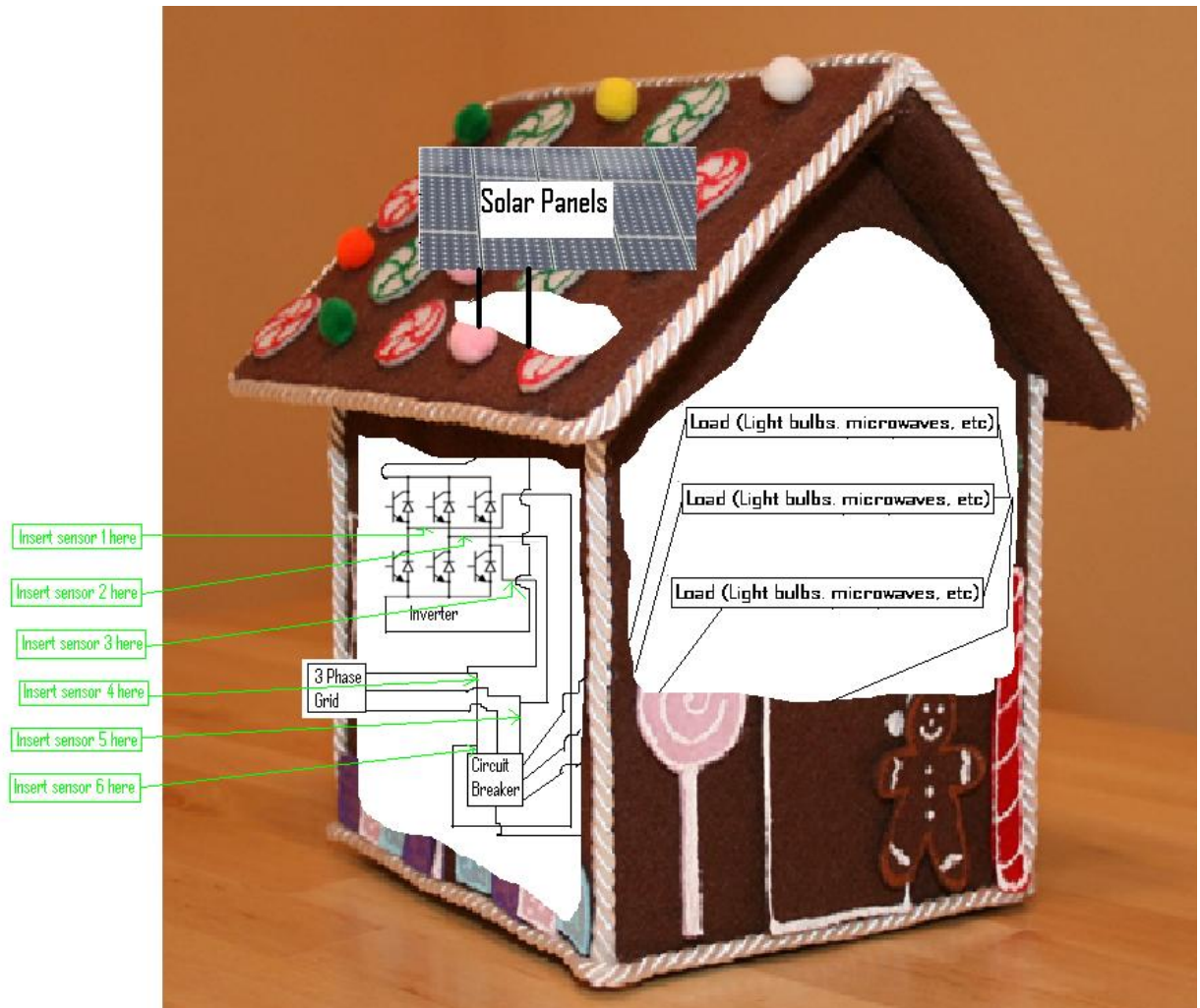

**Figure H-7: Electrical Components in a 3 Phase Power System with PVs and Power**

**Meters**

## Appendix I: Creating Power Sensors From Scratch

### Creating a current sensor:

Materials Needed:

1 to N Step up transformer (Or a 20 meter long wire with a big piece of iron)

1-Ohm resistor

Wires

The circuit below shows a step up transformer linked to the desired current to be measured ( $I$ ). This transformer is attached to a burden resistor  $R_{\text{Burden}}$ .  $R_{\text{OCR}}$  is not something we put there but it shows the natural resistance of the circuit.

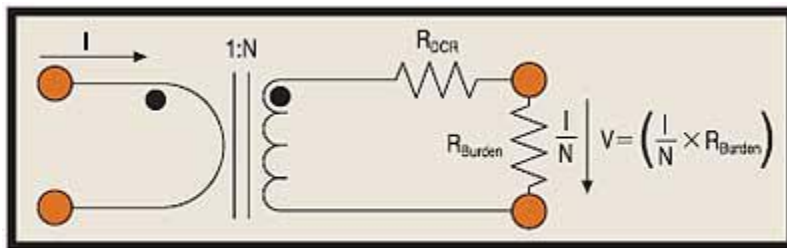

Fig.1. Ideal current transformer circuit.

Figure I-1: Current Transformer Circuit

(Hays, William, 2002)



All electrical data are in states of voltages. For example in a computer a logical high will be 1.3 volts and a logical low will be 0 volts.

Therefore, what we want to do is to get a value of voltage that depends on the value of the current (I). This circuit in figure 1 does just that yielding the equation:

$$V = (R_{\text{Burden}} * I/N)$$

The current transformer works in such a way that whatever current (I) is on the left side, the induced current on the right side is I/N. So that equation is just measuring the voltage drop of a current divider.

So using the equation:  $V = (R_{\text{Burden}} * I/N)$ , N and  $R_{\text{Burden}}$  is constant, therefore we have a voltage value (V) that a computer or a microcontroller can handle.

If one does not have access to a transformer, one needs to make one:

1. Wrap the loop of the insulated wire that the current (I) that is flowing through around the left side of the iron core
2. Wrap N number of loops of another piece of insulated wire on the right side of the iron core

Figure 2 shows a diagram of this operation.

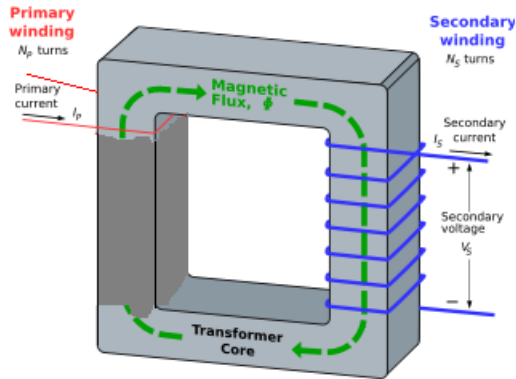

**Figure I-2: Creation of Current Transformer**

**Creating a voltage sensor:**

As previously stated, computers or microcontrollers can read voltage values. However, when voltages become as big as 340 volts, computers and microcontrollers would fry. So we need to step down this voltage while not drawing too much power to measure it.

**Materials Needed:**

One 10Mega ohm Resistor

One 100kilo ohm Resistor

The circuit on figure 3 shows a voltage divider. Replace the 10Mohm resistor with R1

100kilo ohm resistor with R2.

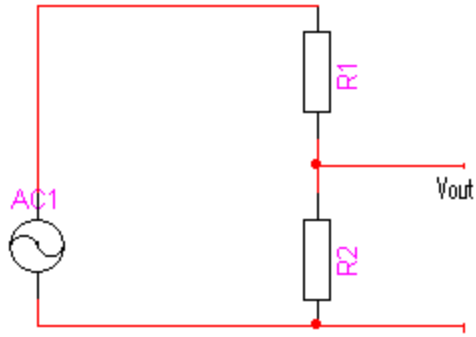

**Figure I-3: Voltage Divider Circuit**

What this does approximately is described by this equation:

$$V_{out} = V_{in}/100.$$

Therefore, if the input voltage is 340 volts, the information outputted to a computer or microcontroller is 3.4 volts, which is very typical for an input port.

## **Appendix J: How to Manually Install the Merton Rule Monitoring System**

The Merton Rule Monitoring System (MRMS) consists of two applications, the Onsite Server Program (OSS) and the Remote Requesting Application (RRA). These instructions are meant for anyone installing the MRMS on Windows Vista or anyone experiencing issues using the install files provided. To install the MRMS manually, you must follow these steps:

1. First, you must copy the file “edtFTPnet.dll” into your C:\Windows\System32\ folder.
2. Double Click the file named SQLEXP32.exe to run the Microsoft SQL Server 2005 installer. To complete this step, follow steps 2 through 10 located in Appendix L.
3. Upon Complete of the Microsoft SQL Server 2005 installer, navigate to your C:\Program Files\ directory, right click and select New > Folder. Name it “MRMS”.

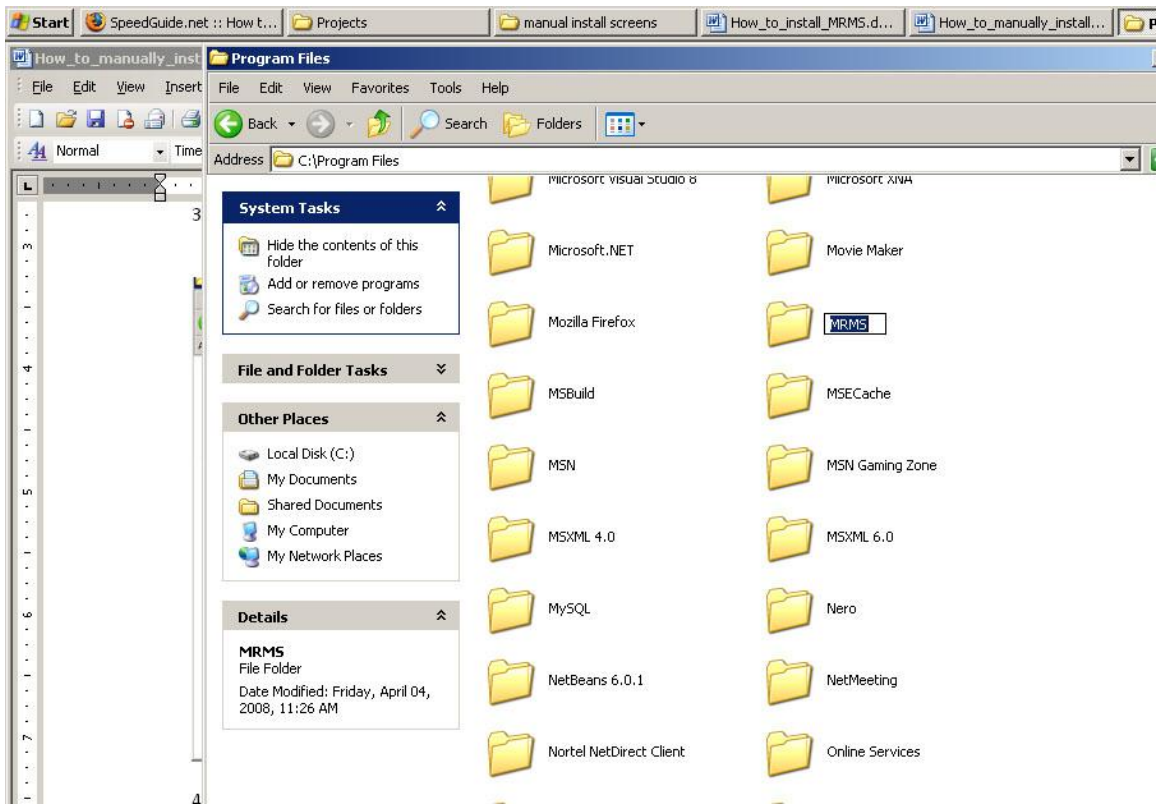
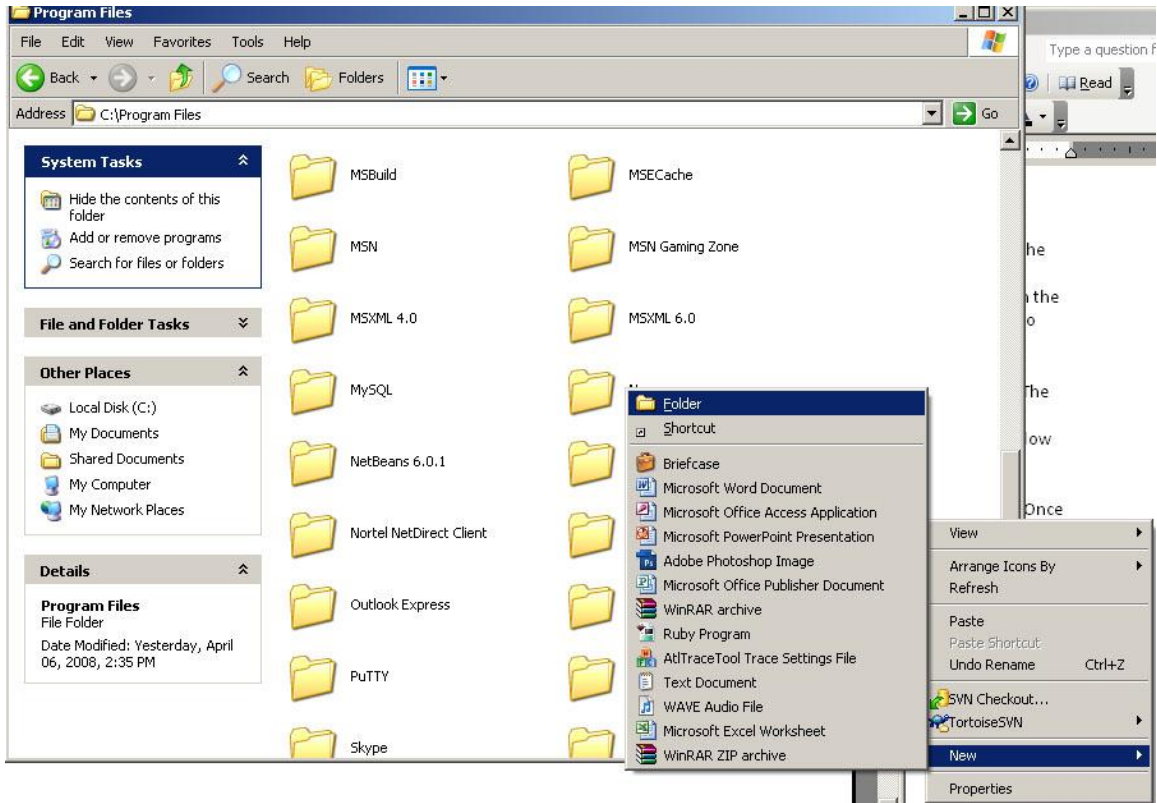

4. Inside the MRMS folder create two more folders named “Onsite Server” and “Remote Requesting Application”

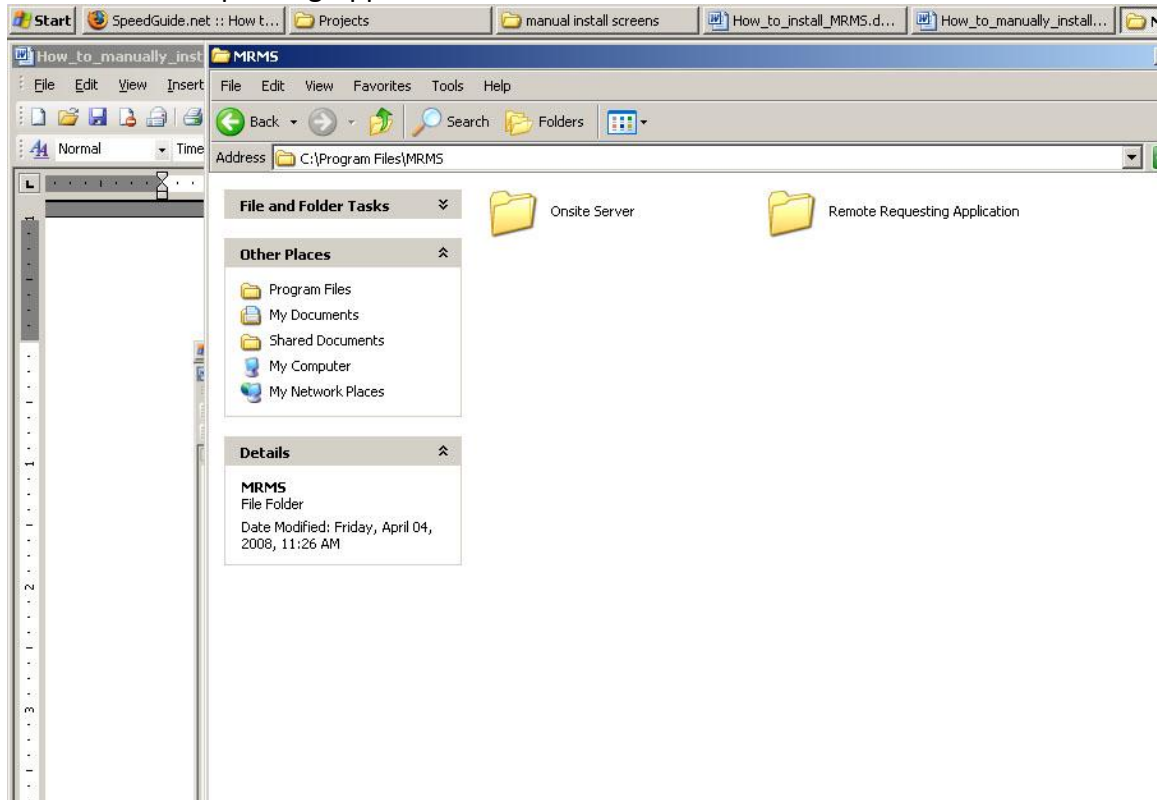

5. From the MRMS CD, copy the contents of the “On-site Server\bin\Debug\” folder into the “Onsite Server” folder just created in step 4.

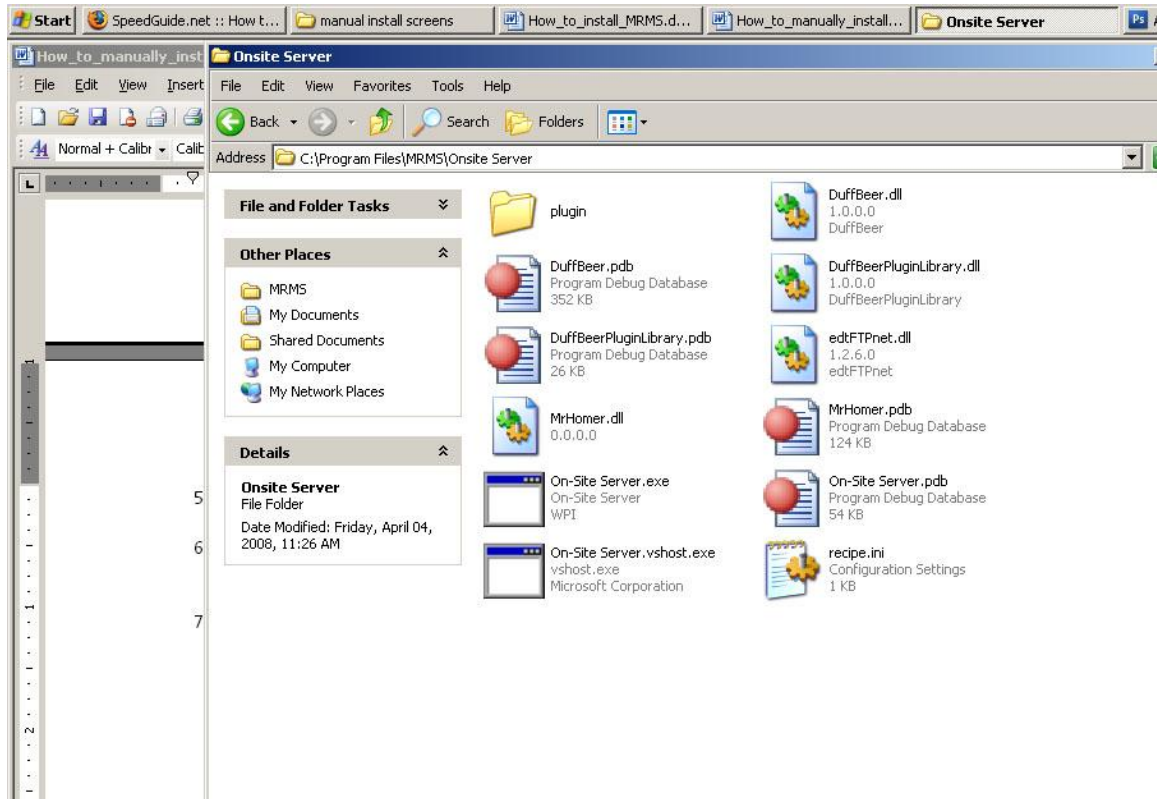

6. From the MRMS CD, copy the contents of the “Remote Requesting Application\bin\Debug\” folder into the “Remote Requesting Application” folder just created in step 4.

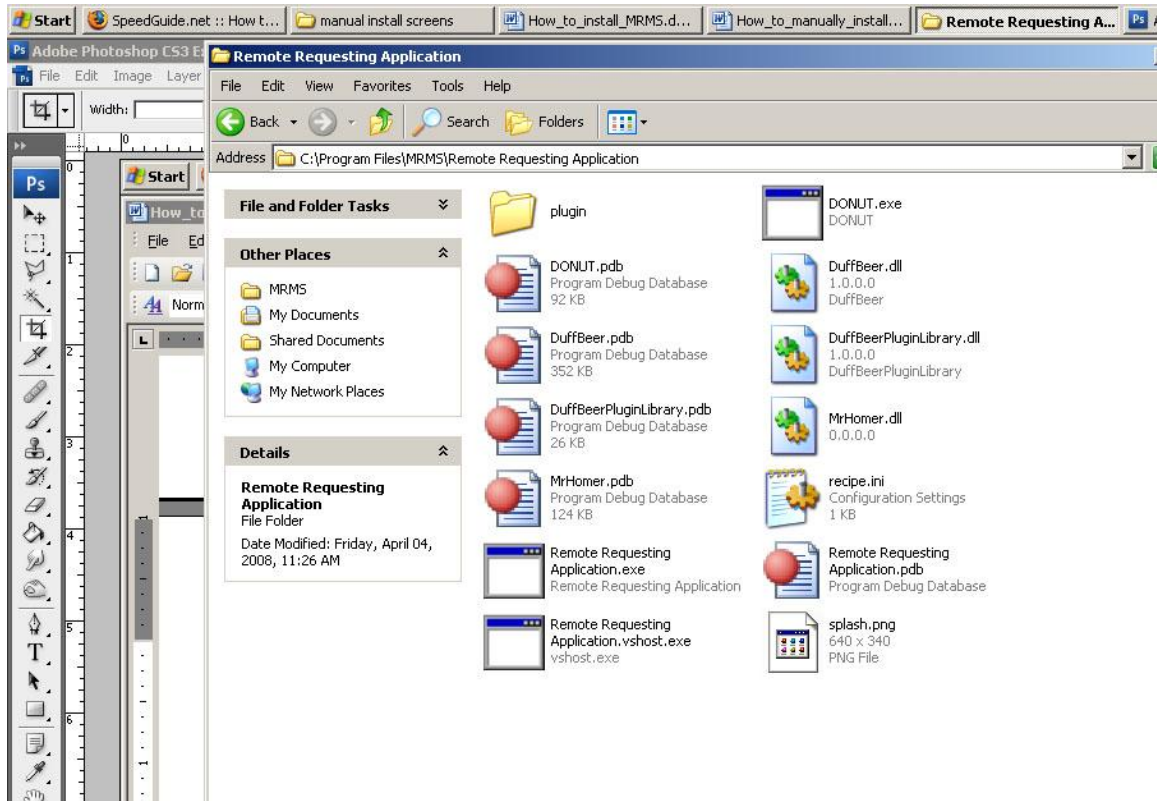

7. Next, from the MRMS CD, right click on the file called “database\_setup.bat” and if you are on Windows Vista select “Run as Administrator” if you are on Windows 2000/XP select “Open”. This is the final step in installing the MRMS.



## Appendix K: Contents of MRMS CD

This appendix contains a list of the items on the MRMS install CD and explanations for important files and folders. The MRMS install CD contains these items:

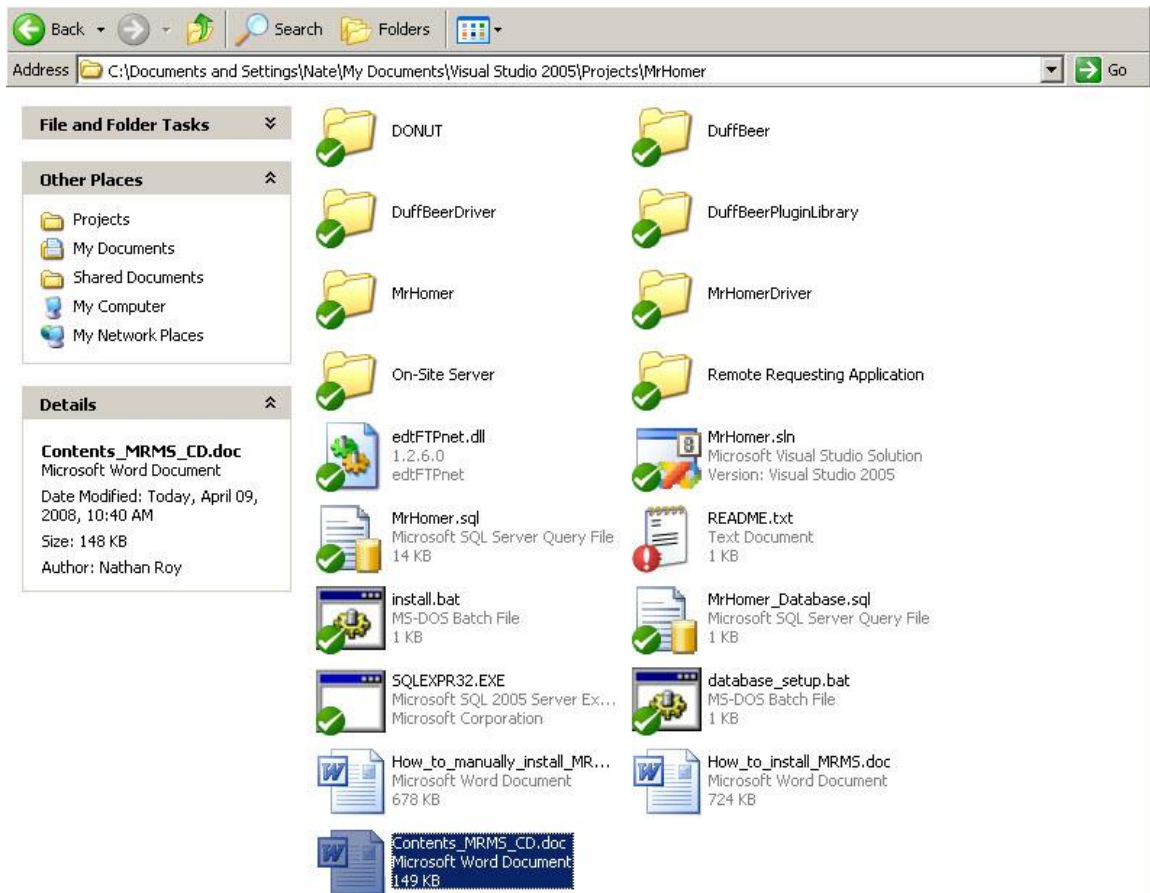

- \DONUT – This folder contains source code and binary files for the DONUT project.
- \DuffBeer – This folder contains the source code and binary files for the DuffBeer (Data Unification, Feedback, and Filing Back-End for Energy Reporting) project.

- \DuffBeerDriver – This folder contains the source code and executable files for the DuffBeerDriver project, this is a sample application developed by the previous IQP team to test their code.
- \DuffBeerPluginLibrary – This folder contains the source code and binary files for sample plug-ins developed using the DuffBeer project.
- \MrHomer – This folder contains all the source code and binary files for the MrHomer (Merton Hierarchical Online Monitoring and Energy Reporting) project. This code is the framework that provides some common functionality to both the Onsite Server program and the Remote Requesting Application.
- \MrHomerDriver – This folder contains the source code and binary files for the MrHomerDriver project. This project is a test application developed by the previous IQP team to test the functionality of the MrHomer framework.
- \On-site Server – This folder contains all of the source code and executable files for the Onsite Server Program. The executable files are located in the \On-site Server\bin\Debug\ folder.
- \Remote Requesting Application\ - This folder contains all of the source code and executable files for the Remote Requesting Application. The executable files are located in the \Remote Requesting Application\bin\Debug\ folder.
- edtFTPnet.dll – This file is used by the PV Sensor in the On Site Server Program in order to provide file transfers over FTP. After installing the MRMS, this file will be copied to your C:\Windows\system32 folder.
- MrHomer.sln – This is the Visual Studio solution file for all of the MrHomer Projects (including the MRMS applications), this will allow you to edit the source code of the MrHomer applications in Visual Studio. To use this, you must first copy the contents of the MRMS CD to your local hard drive.
- MrHomer.sql – This file is used during MRMS installation to prepare the database for use in the MRMS. It creates all of the tables and keys needed for the MRMS programs to log information to a database.
- README.txt – This file contains some information that should be read before installing MRMS.
- Install.bat – This file is a batch file that is used to install the MRMS system on machines running Windows 2000/XP.
- MrHomer\_Database.sql – This file is used to create a new database installation for use with MRMS. Using this file will delete any information previously stored in the database MrHomer if it exists, so it is best used for setting up a database for the first time on a machine.
- SQLEXP32.EXE – This file is the installer for the Microsoft SQL Server 2005 database program. This needs to be run in order to allow the MRMS programs to use a database to log information.
- Database\_setup.bat – This file is used after running install.bat, to prepare the database for use with MRMS. This file requires that both MrHomer.sql and MrHomer\_Database.sql are located on your Desktop.

- How\_to\_manually\_install\_MRMS.doc – This file provides instructions for how to perform a manual install of the MRMS system. Manual installs are only necessary if the easier installs do not work.
- How\_to\_install\_MRMS.doc – This file provides instructions for how to perform a normal install of the MRMS system. This method of install should be used first, if it does not work, use the manual install instructions.
- Contents\_MRMS\_CD.doc – This file lists the contents of the MRMS install CD and provides descriptions for important files and folders.

## **Appendix L: How to Install the Merton Rule Monitoring System**

The Merton Rule Monitoring System (MRMS) consists of two applications, the Onsite Server Program (OSS) and the Remote Requesting Application (RRA). These install instructions are only valid for Windows XP. Windows Vista cannot work with the installer file and the MRMS has to be installed manually. For instructions on how to install the MRMS manually, see Appendix J. To install the MRMS:

1. Place the MRMS CD into the CD tray and double click the file “install.bat”. The program will first install the MRMS components. Next it will launch the Microsoft SQL Server Installer. To properly install Microsoft SQL Server, follow the instructions below for each screen in the installer:
2. When the installer starts, you will see a small box entitled Extracting Files. Once that screen goes away, a screen appears where you must accept the license agreement and click the “Next” button.

3. On the next screen (entitled: Installing Prerequisites), wait for it to finish, then click the “Next” button.

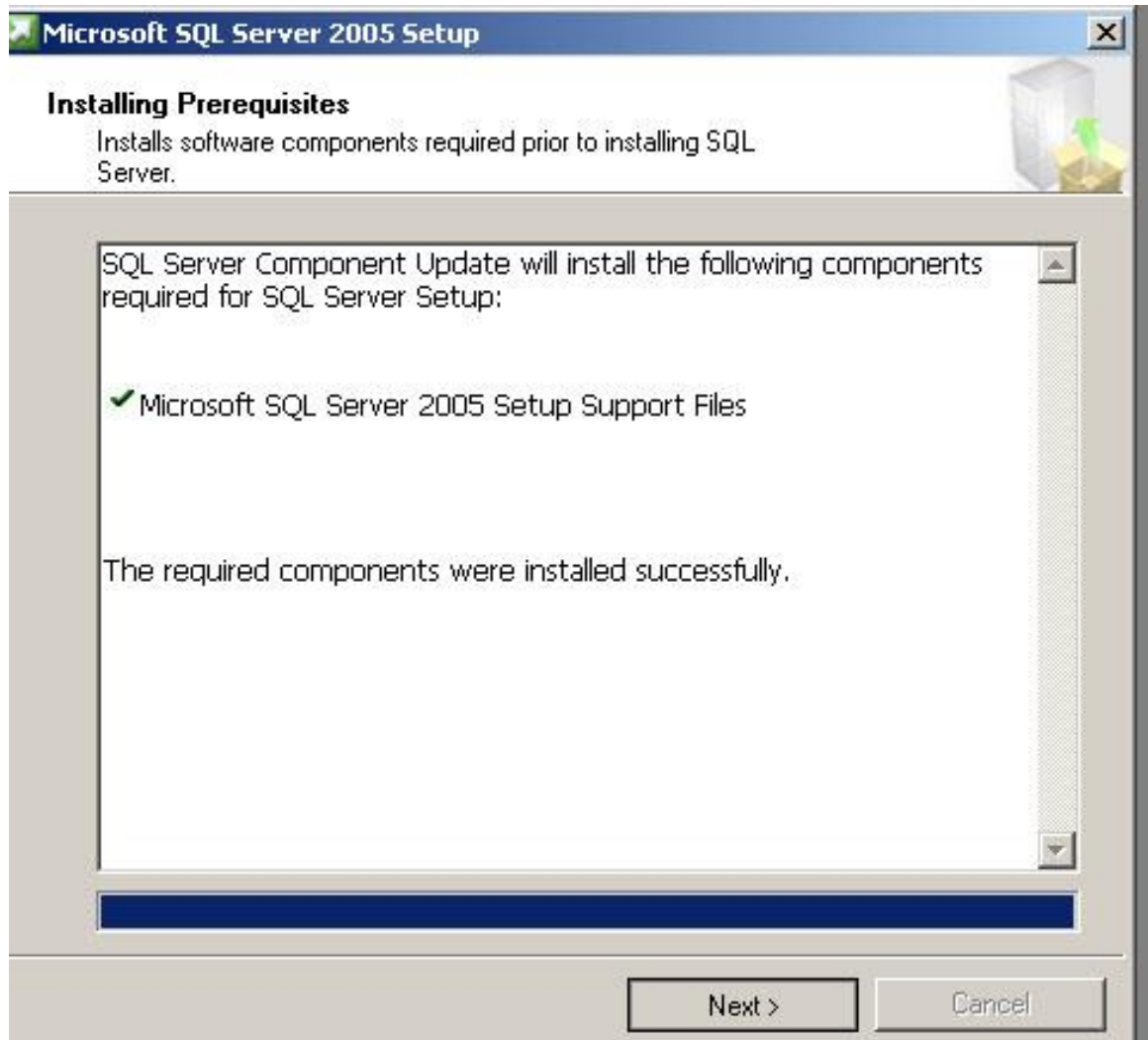

4. On the Microsoft SQL Server Installation Wizard welcome screen, press the next button to continue, at the next screen (entitled: System Configuration Check) click next once it is complete.

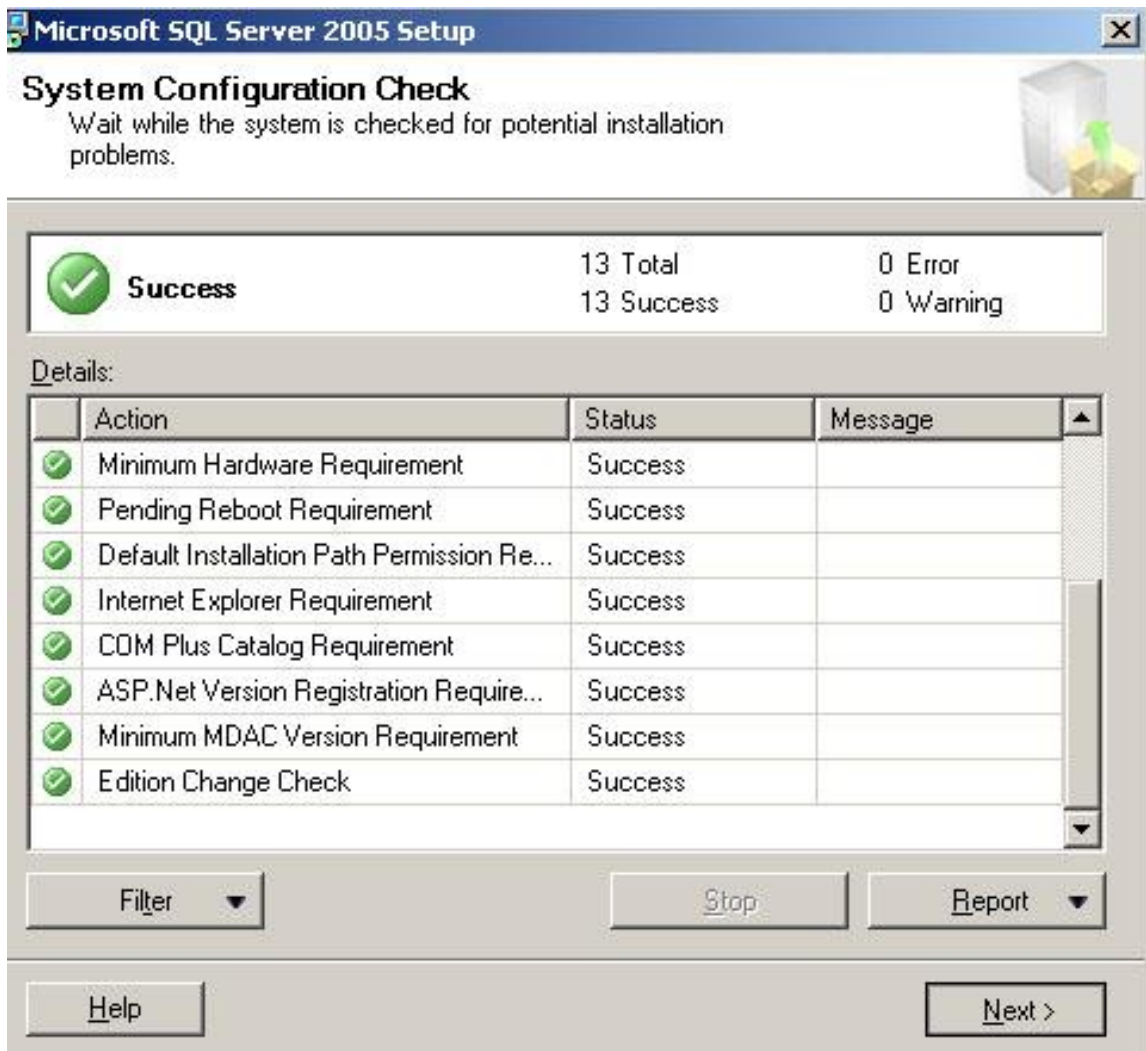

5. At the next screen (entitled: Registration Information), enter the information requested and press next.

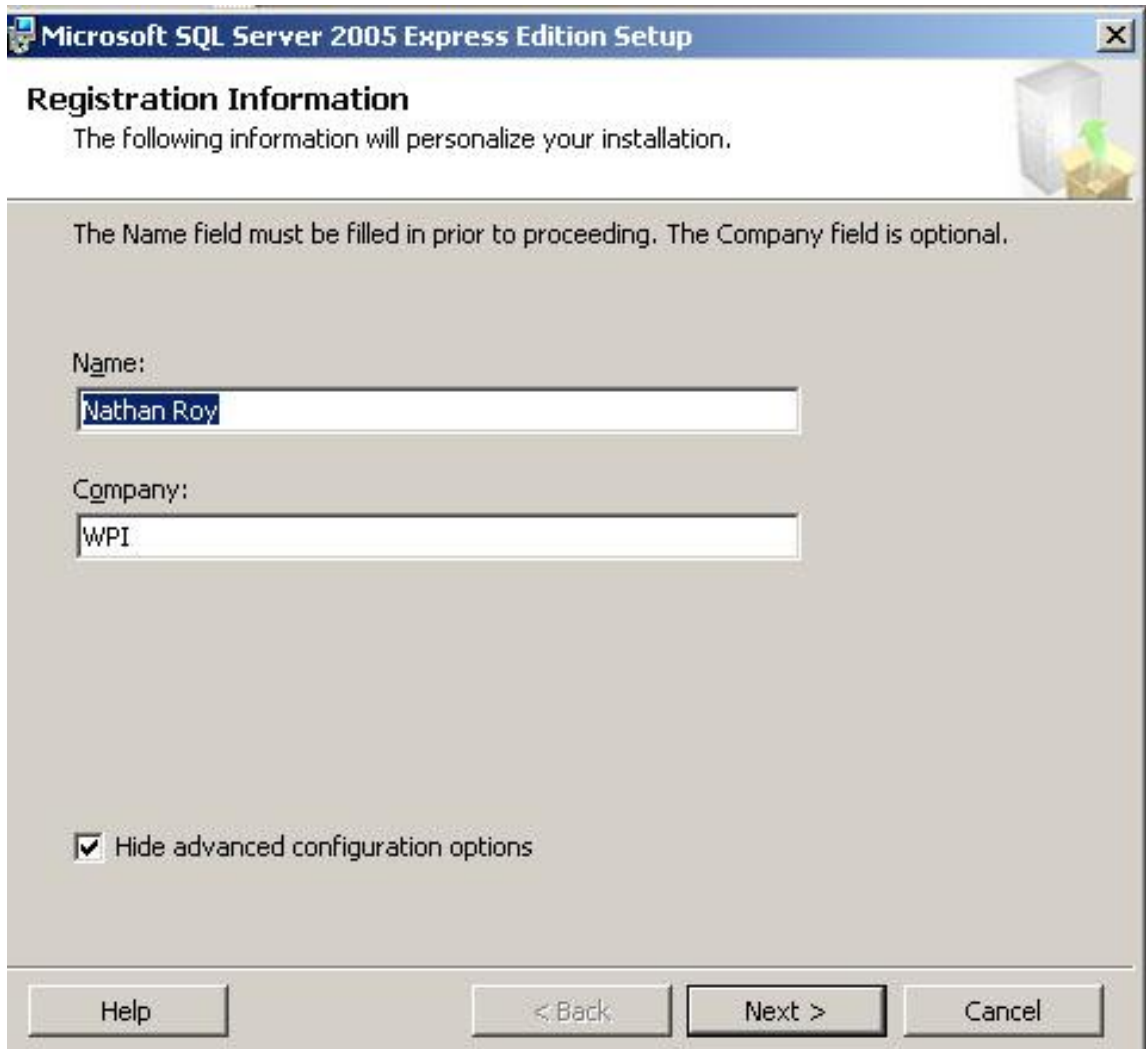

6. On the next screen (entitled: Feature Selection), click on the dropdown menu next to "Database Services" and select "Entire feature will be installed on local hard drive", do the same for the dropdown menu next to "Client Components".

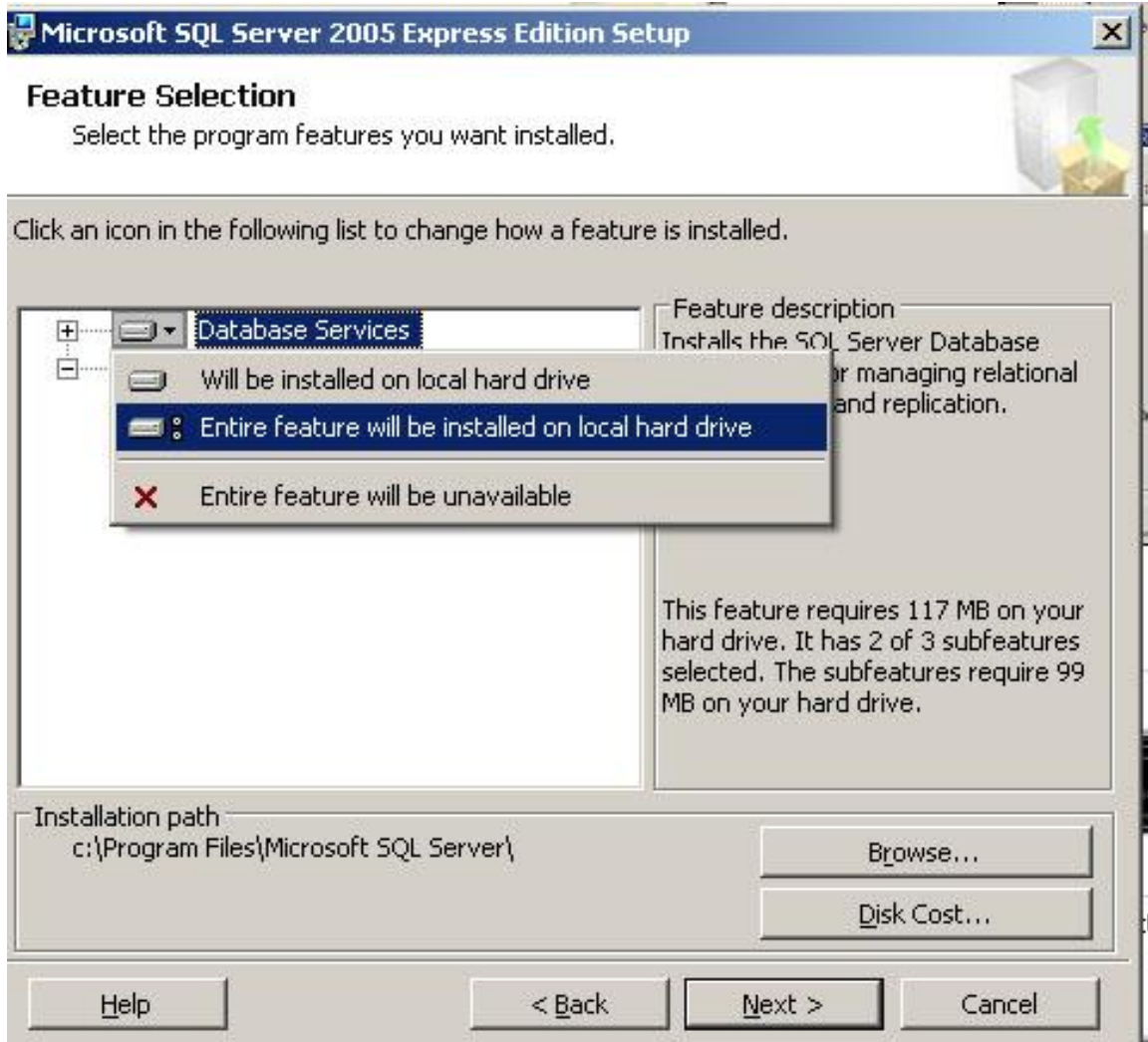

After selecting the information from the dropdown menus, the screen should look like:



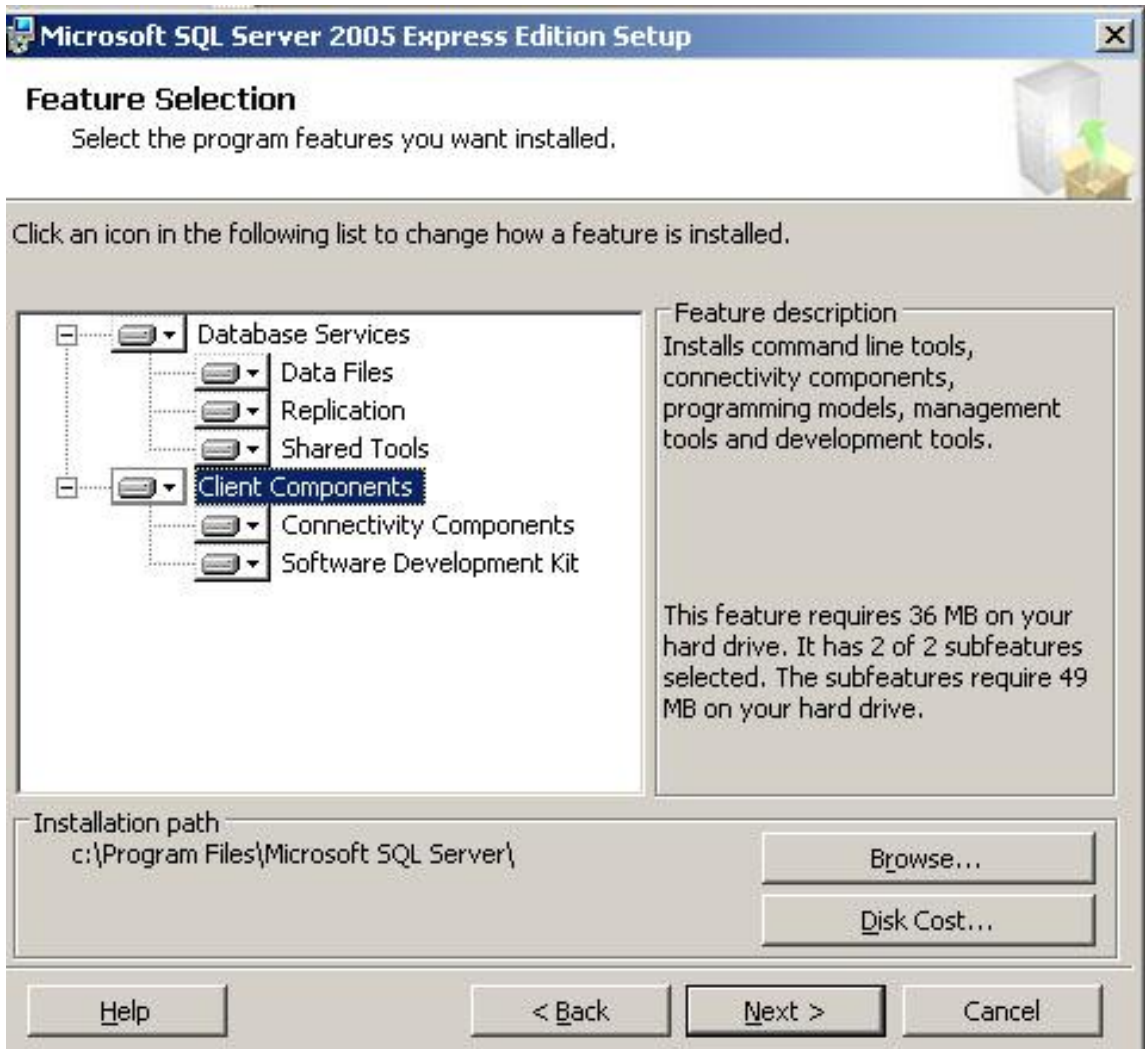

7. Now, click the "Next" button to continue. At the next screen (entitled: Authentication Selection) make sure "Windows Authentication Mode" is selected and then click the "Next" button.

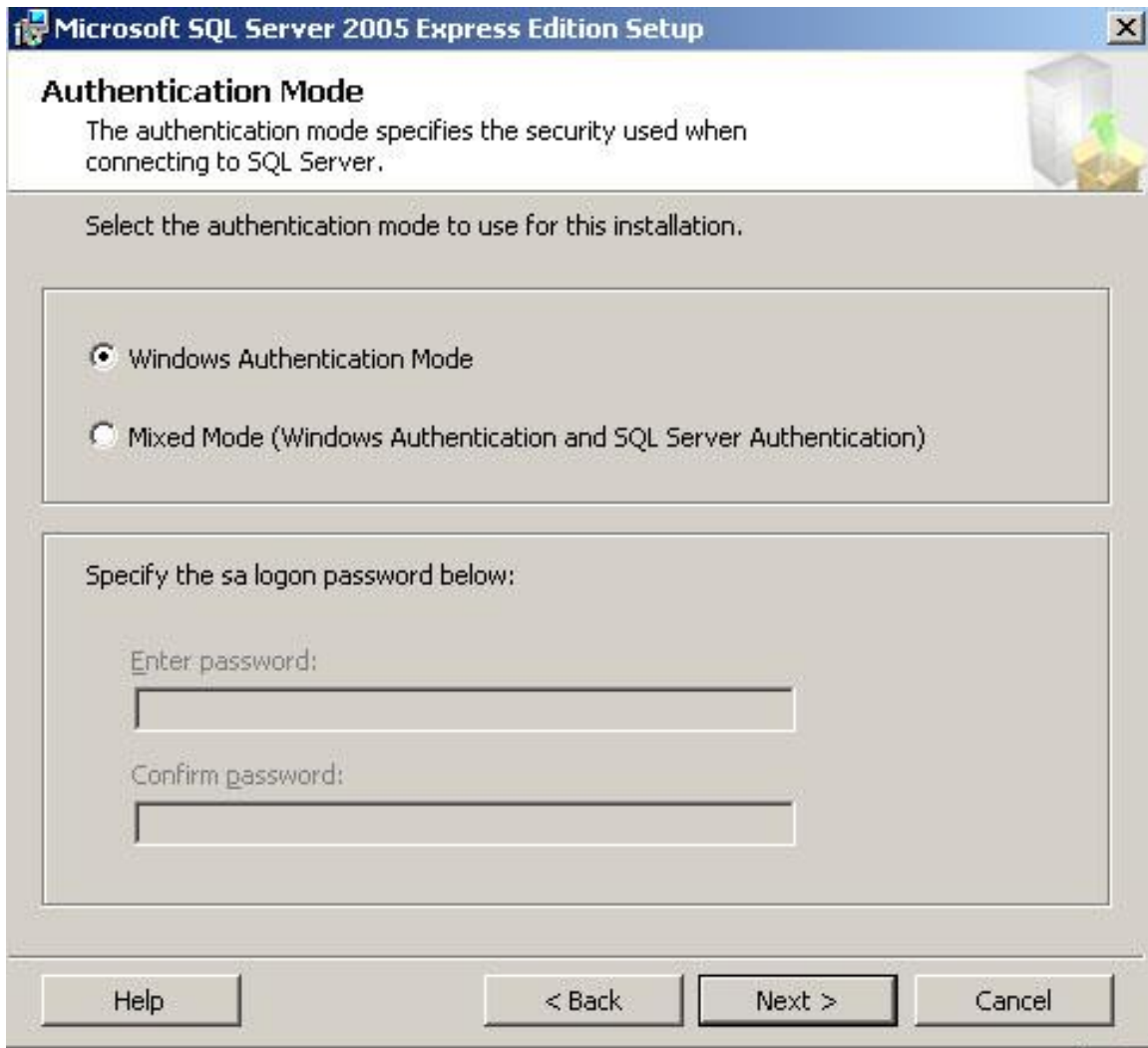

8. At the next screen (entitled: Configuration Options), select both checkboxes and click the "Next" button to continue.

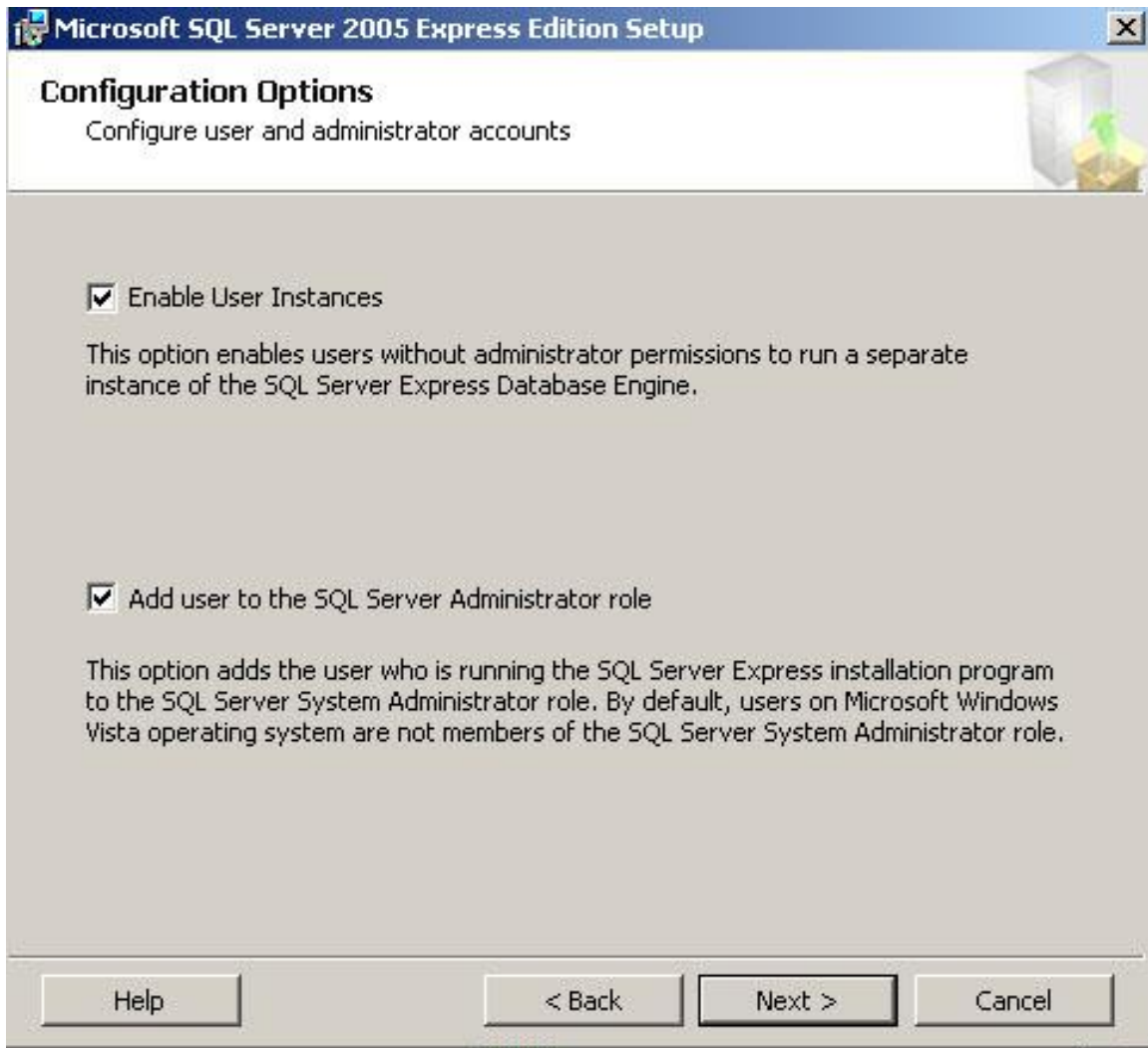

9. At the next screen (entitled: Error Usage and Report Settings), leave the settings as they were and click the "Next" button. At the subsequent screen, click the "Install" button to begin the install of Microsoft SQL Server 2005.

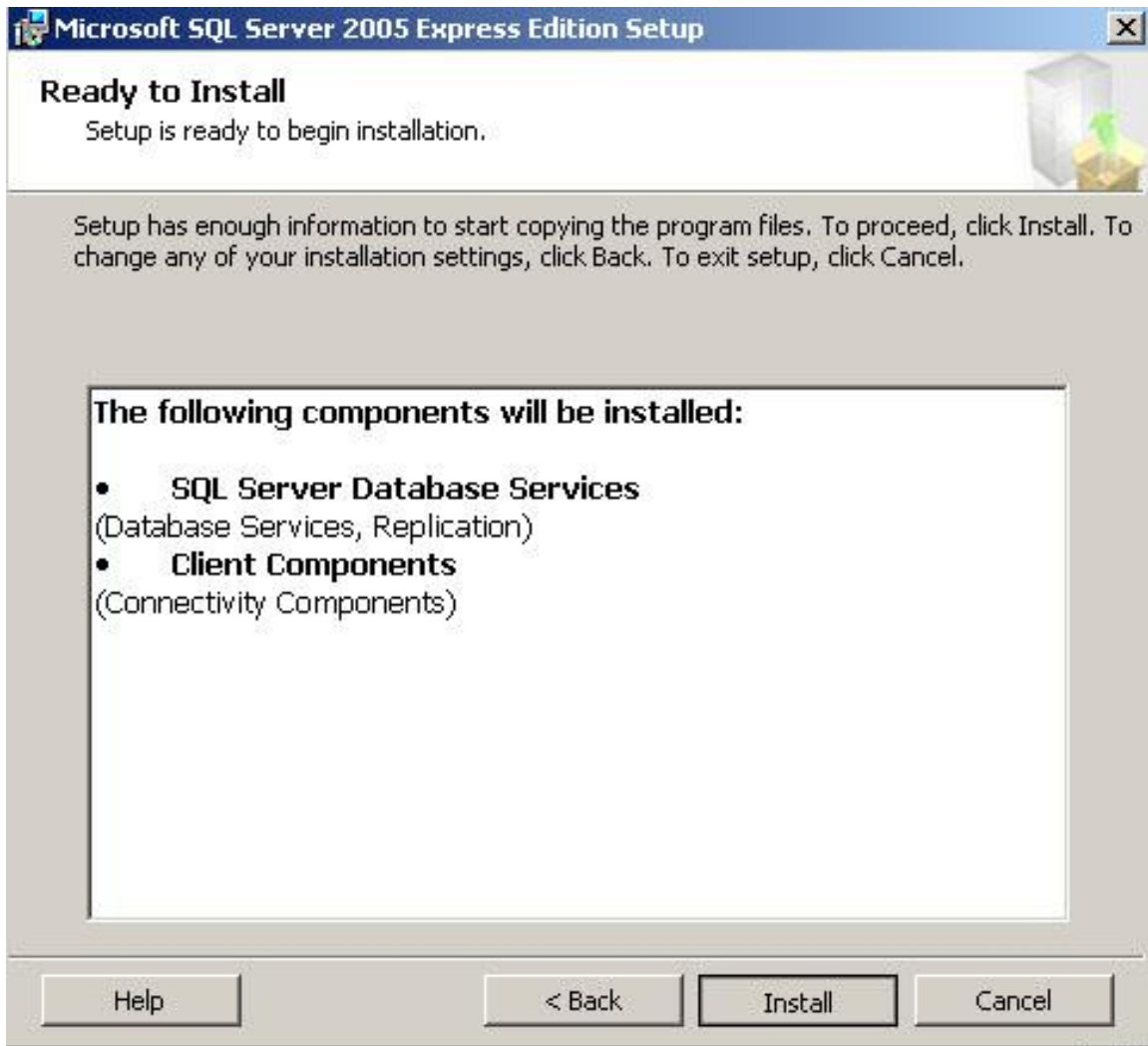

10. The install screen will appear and will physically install Microsoft SQL Server 2005. Wait for the install to complete.

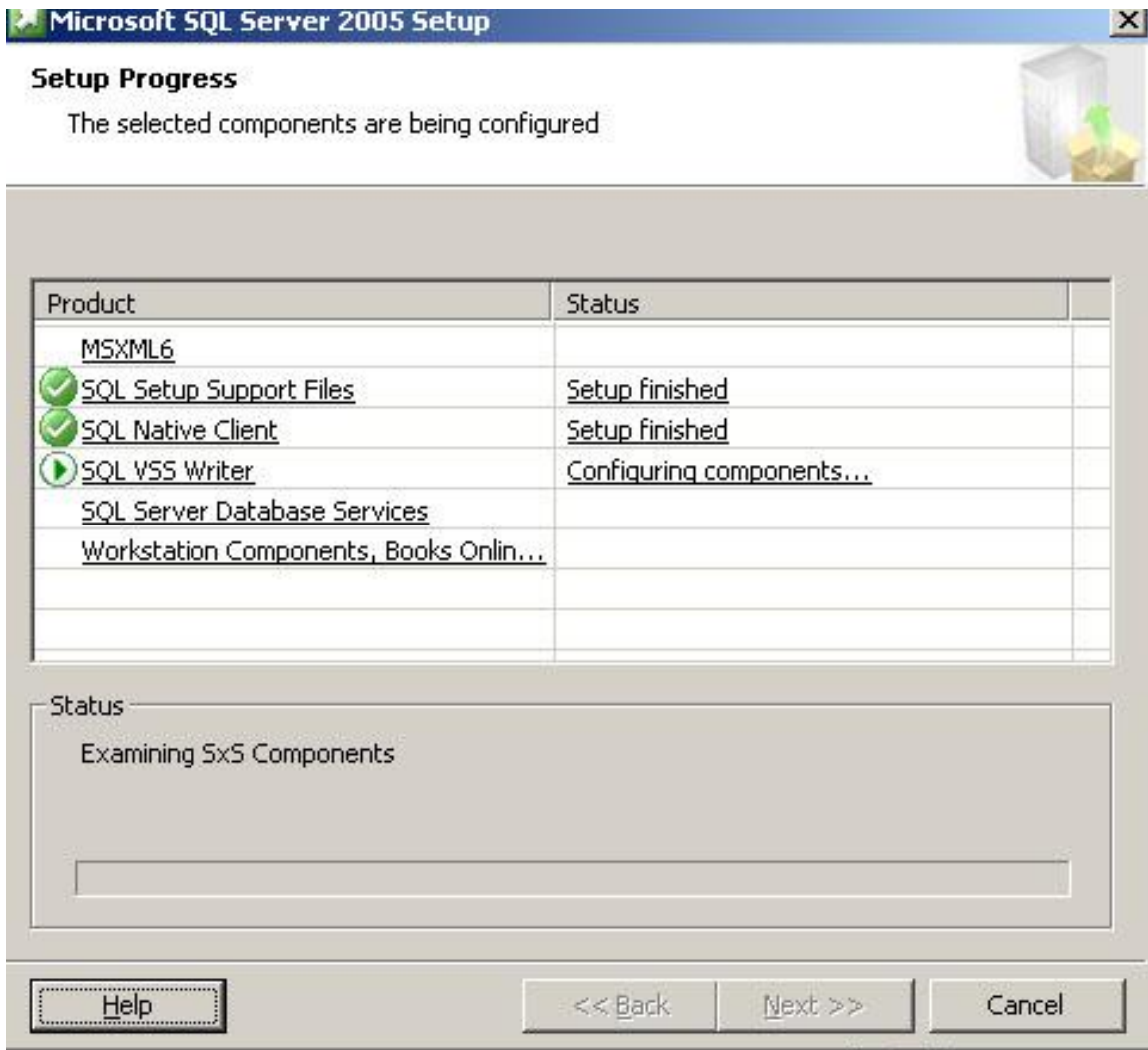

11. Once the install is completed, click the "Next" button. At the final screen click the "Finish" button and your install of Microsoft SQL Server 2005 is complete.

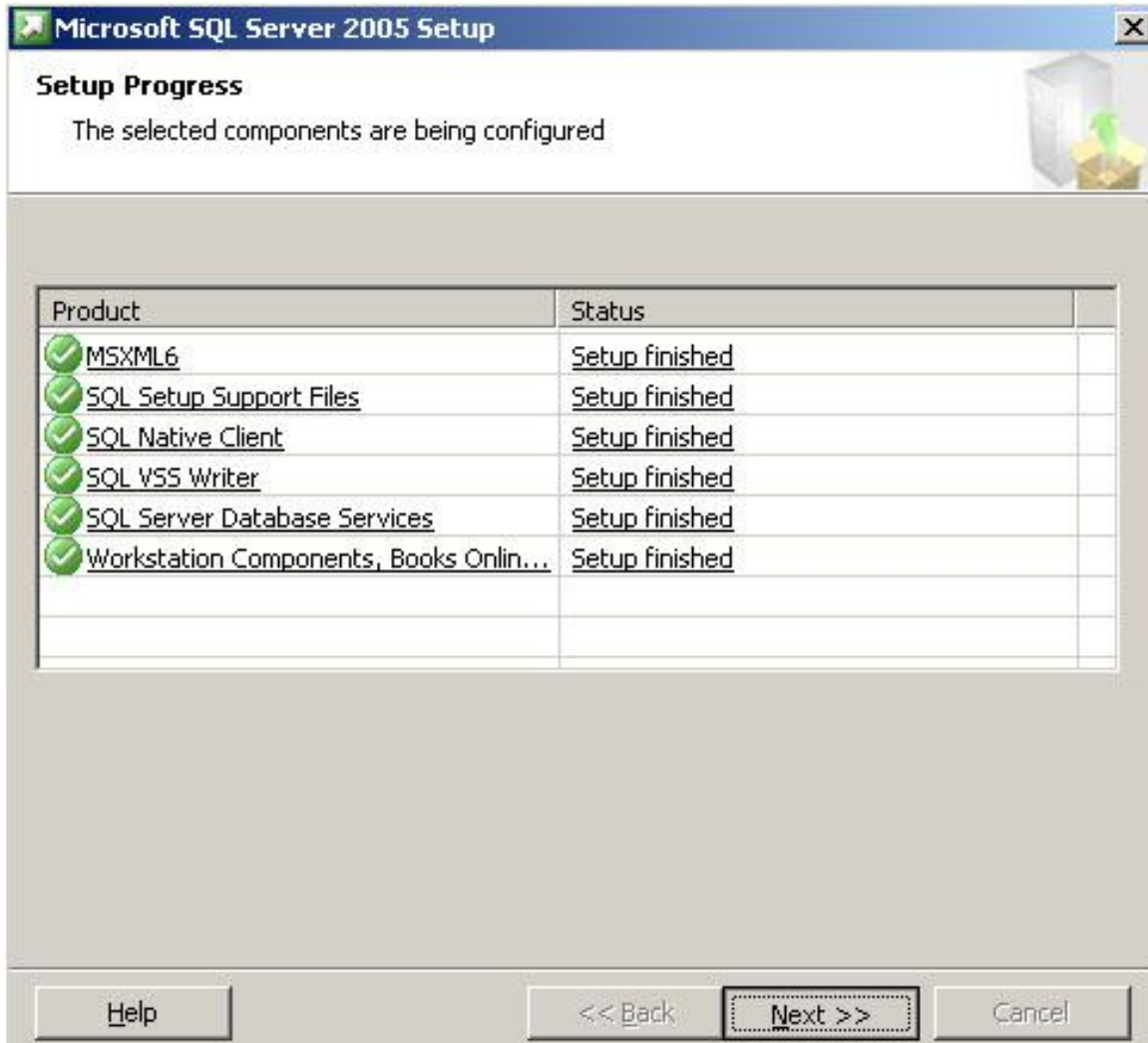

12. Now that the "install.bat" is complete, double click on the "database\_setup.bat" file.
13. The MRMS should now be installed to your "C:\Program Files\MRMS\" directory.

You may now run the Onsite Server by navigating to your "C:\Program Files\MRMS\On Site Server" and double clicking On-site Server.exe. Also, you can run the Remote Requesting Application by navigating to your "C:\Program

Files\MRMS\Remote Requesting Application” and double clicking Remote Requesting Application.exe.

## **Appendix M: How to Use the Onsite Server Program**

The Onsite Server Program (OOS) was written by Nathan Roy as part of the Merton Rule Monitoring System (MRMS) prototype system, with some code examples used from the team who developed MrHomer for the previous project. The main purpose of the OOS is to run on a computer in the Merton Rule buildings and collect data about the various sensors installed onsite. The secondary purpose of the OOS is to send data to a remote program upon request. This guide will provide a walkthrough of what the program is doing during various important activities.

Once the Onsite Server program has been installed as explained in Appendix L you can start the Onsite Server by double clicking on “On Site Server.exe” in your installation directory. The Program will then be running and is not closeable unless killed in the Windows Task Manager. This is to prevent accidental shutdown of the server.

Once started, the program logs information when specific events occur during the execution. Once the program is started it will briefly initialize itself and begin execution. Once it is ready, it will print the message “Initialization Complete...”:



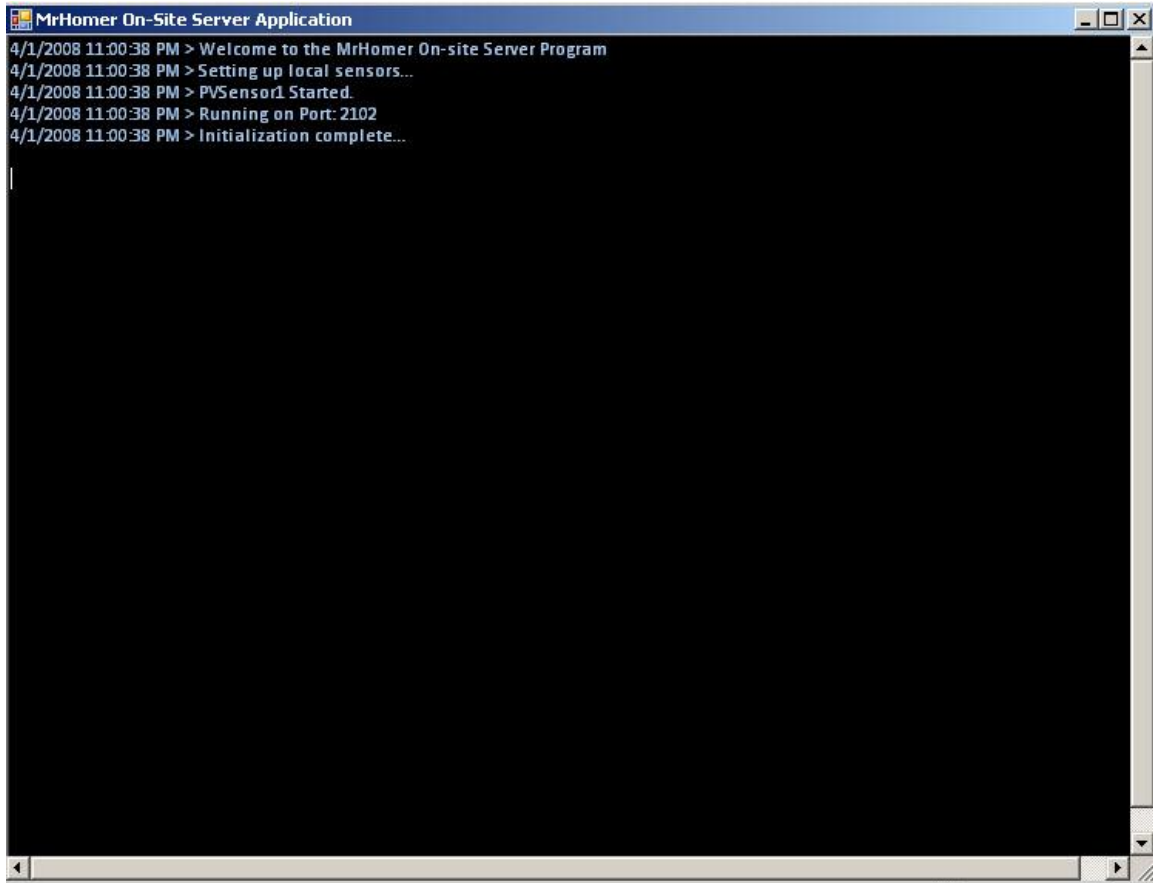

```
MrHomer On-Site Server Application
4/1/2008 11:00:38 PM > Welcome to the MrHomer On-site Server Program
4/1/2008 11:00:38 PM > Setting up local sensors...
4/1/2008 11:00:38 PM > PVSensor1 Started.
4/1/2008 11:00:38 PM > Running on Port: 2102
4/1/2008 11:00:38 PM > Initialization complete...
```

The Onsite Server program logs information about important events during its execution. The important events include:

When the server logs information from a sensor into the database it will print a notification about which sensor it has saved information for:

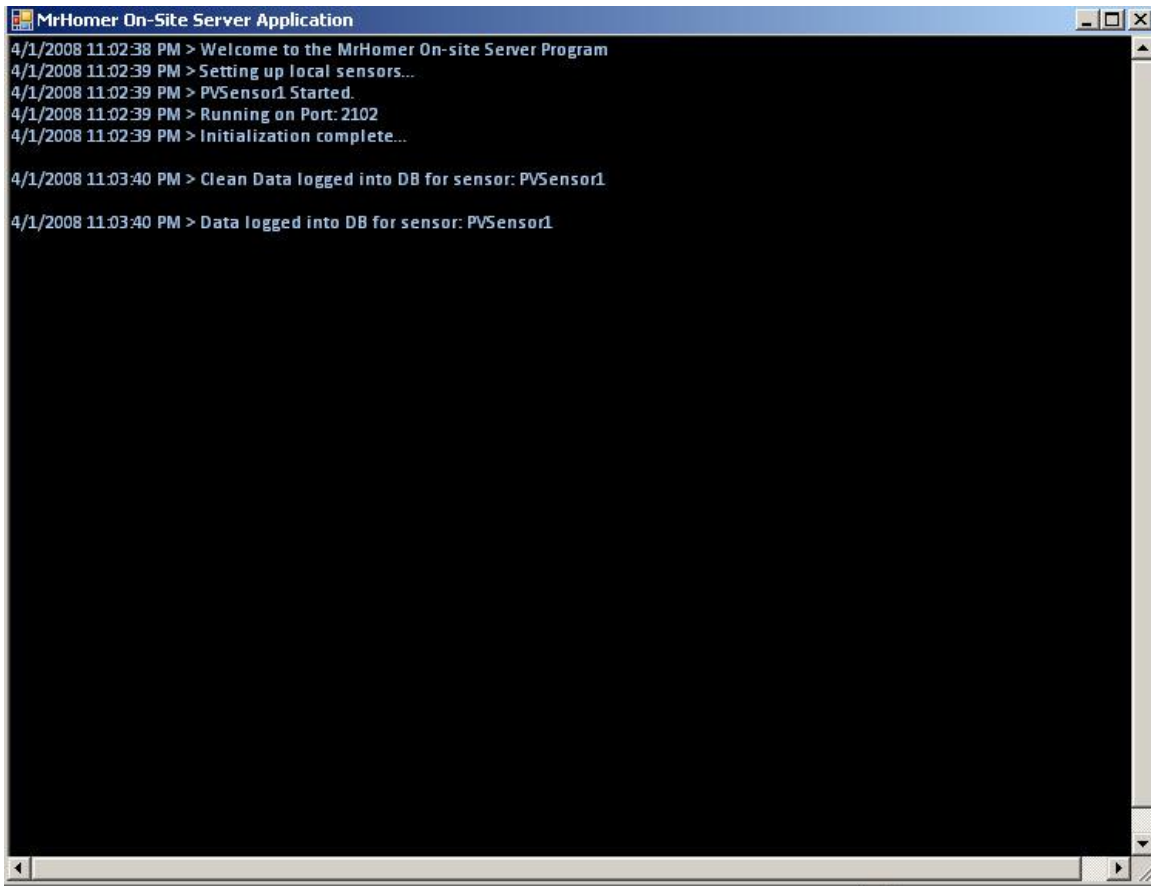

```
MrHomer On-Site Server Application
4/1/2008 11:02:38 PM > Welcome to the MrHomer On-site Server Program
4/1/2008 11:02:39 PM > Setting up local sensors...
4/1/2008 11:02:39 PM > PVSensor1 Started.
4/1/2008 11:02:39 PM > Running on Port: 2102
4/1/2008 11:02:39 PM > Initialization complete...

4/1/2008 11:03:40 PM > Clean Data logged into DB for sensor: PVSensor1

4/1/2008 11:03:40 PM > Data logged into DB for sensor: PVSensor1
```

When a remote computer has made a connection with the server, it will print the IP (Internet Protocol) address and port number that it has connected on:

```
MrHomer On-Site Server Application
4/1/2008 11:02:38 PM > Welcome to the MrHomer On-site Server Program
4/1/2008 11:02:39 PM > Setting up local sensors...
4/1/2008 11:02:39 PM > PVSensor1 Started.
4/1/2008 11:02:39 PM > Running on Port: 2102
4/1/2008 11:02:39 PM > Initialization complete...

4/1/2008 11:03:40 PM > Clean Data logged into DB for sensor: PVSensor1

4/1/2008 11:03:40 PM > Data logged into DB for sensor: PVSensor1

4/1/2008 11:04:43 PM > Clean Data logged into DB for sensor: PVSensor1

4/1/2008 11:04:43 PM > Data logged into DB for sensor: PVSensor1

4/1/2008 11:04:48 PM > 127.0.0.1:2823 connected to the server.

|
```

When a remote computer requests the list of installed and running sensors from the server, it prints data regarding the event:

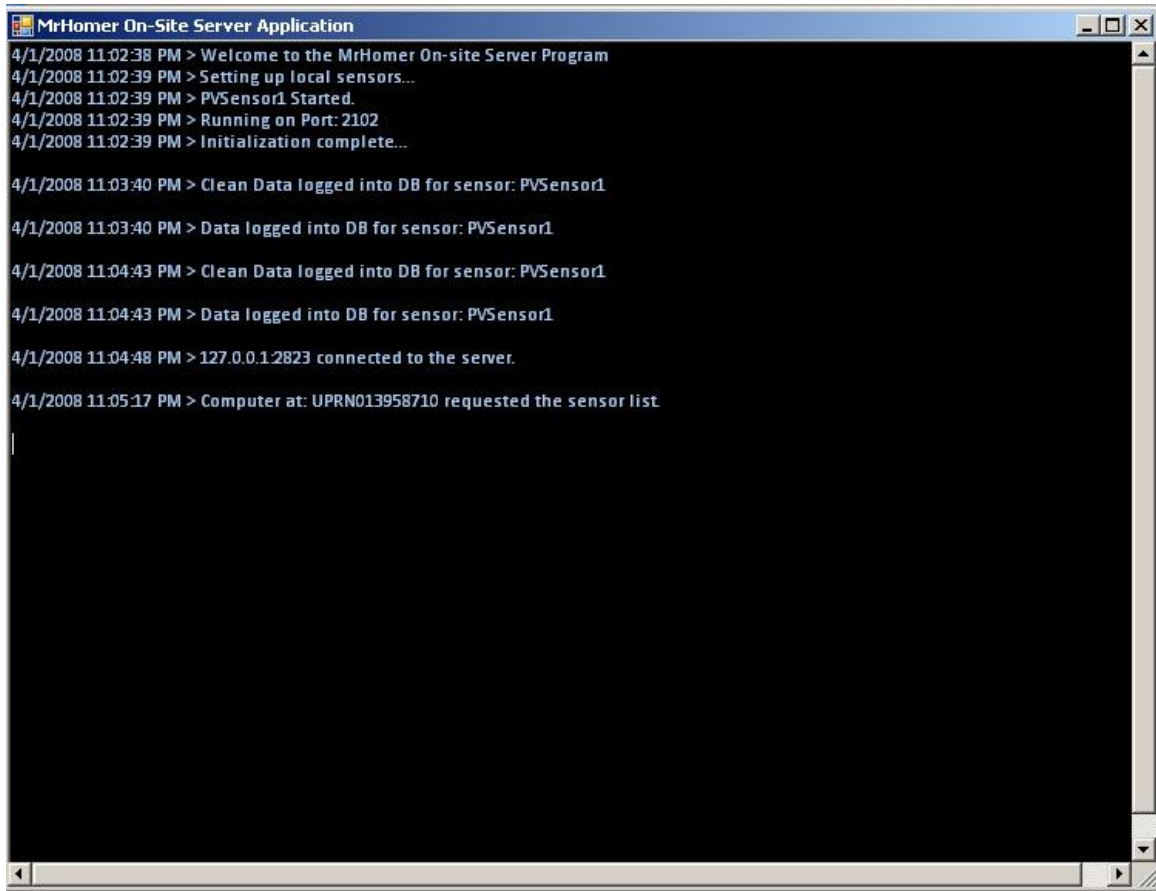

```
MrHomer On-Site Server Application
4/1/2008 11:02:38 PM > Welcome to the MrHomer On-site Server Program
4/1/2008 11:02:39 PM > Setting up local sensors...
4/1/2008 11:02:39 PM > PVSensor1 Started.
4/1/2008 11:02:39 PM > Running on Port: 2102
4/1/2008 11:02:39 PM > Initialization complete...

4/1/2008 11:03:40 PM > Clean Data logged into DB for sensor: PVSensor1

4/1/2008 11:03:40 PM > Data logged into DB for sensor: PVSensor1

4/1/2008 11:04:43 PM > Clean Data logged into DB for sensor: PVSensor1

4/1/2008 11:04:43 PM > Data logged into DB for sensor: PVSensor1

4/1/2008 11:04:48 PM > 127.0.0.1:2823 connected to the server.

4/1/2008 11:05:17 PM > Computer at: UPRN013958710 requested the sensor list
|
```

When a remote computer requests the most recent reading from a sensor, the server prints information regarding which sensor was requested and which remote connection requested the information:

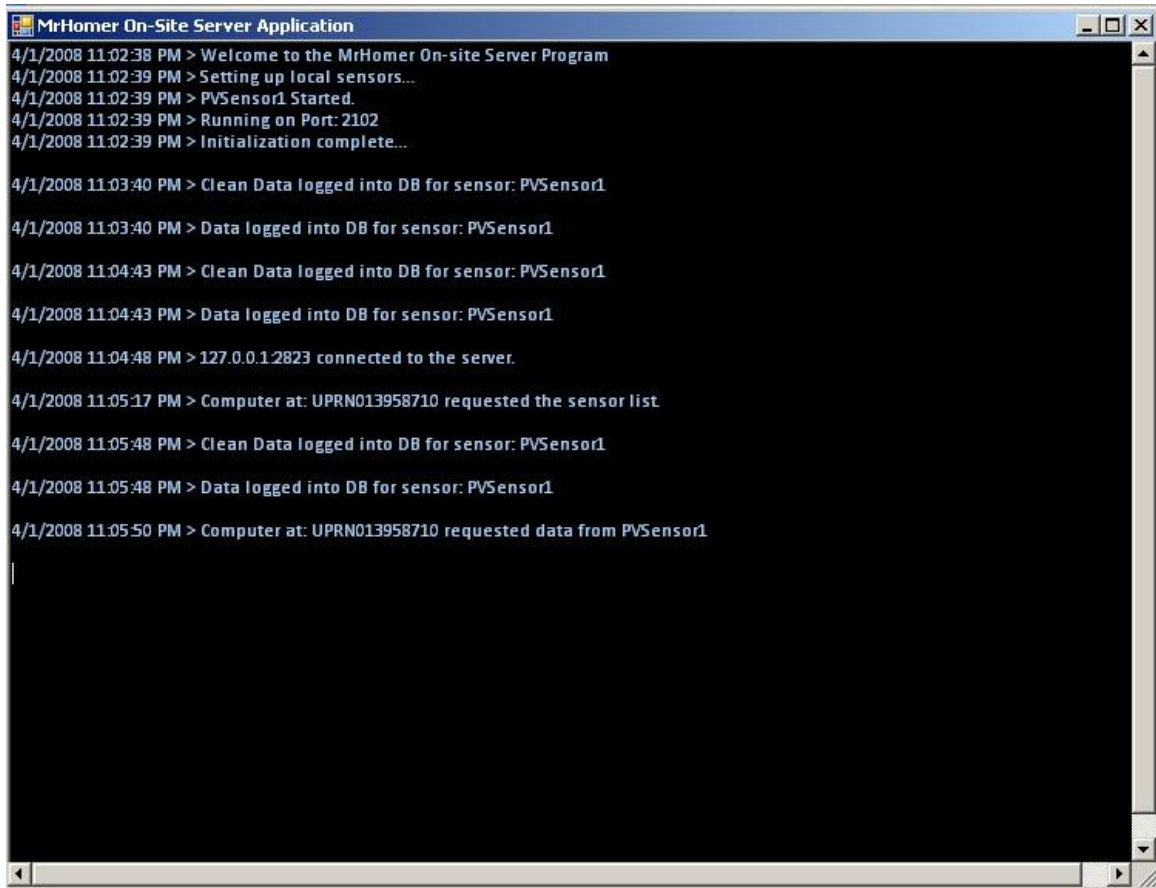
A screenshot of a Windows application window titled "MrHomer On-Site Server Application". The window contains a log of events. The log entries are as follows:

```
4/1/2008 11:02:38 PM > Welcome to the MrHomer On-site Server Program
4/1/2008 11:02:39 PM > Setting up local sensors...
4/1/2008 11:02:39 PM > PVSensor1 Started.
4/1/2008 11:02:39 PM > Running on Port: 2102
4/1/2008 11:02:39 PM > Initialization complete...

4/1/2008 11:03:40 PM > Clean Data logged into DB for sensor: PVSensor1

4/1/2008 11:03:40 PM > Data logged into DB for sensor: PVSensor1

4/1/2008 11:04:43 PM > Clean Data logged into DB for sensor: PVSensor1

4/1/2008 11:04:43 PM > Data logged into DB for sensor: PVSensor1

4/1/2008 11:04:48 PM > 127.0.0.1:2823 connected to the server.

4/1/2008 11:05:17 PM > Computer at: UPRN013958710 requested the sensor list

4/1/2008 11:05:48 PM > Clean Data logged into DB for sensor: PVSensor1

4/1/2008 11:05:48 PM > Data logged into DB for sensor: PVSensor1

4/1/2008 11:05:50 PM > Computer at: UPRN013958710 requested data from PVSensor1

|
```

The final important event the server logs is when a remote computer terminates connection with the server. When this happens, the server prints information regarding which computer disconnected from the server:

```
MrHomer On-Site Server Application
4/1/2008 11:02:38 PM > Welcome to the MrHomer On-site Server Program
4/1/2008 11:02:39 PM > Setting up local sensors...
4/1/2008 11:02:39 PM > PVSensor1 Started.
4/1/2008 11:02:39 PM > Running on Port: 2102
4/1/2008 11:02:39 PM > Initialization complete...

4/1/2008 11:03:40 PM > Clean Data logged into DB for sensor: PVSensor1

4/1/2008 11:03:40 PM > Data logged into DB for sensor: PVSensor1

4/1/2008 11:04:43 PM > Clean Data logged into DB for sensor: PVSensor1

4/1/2008 11:04:43 PM > Data logged into DB for sensor: PVSensor1

4/1/2008 11:04:48 PM > 127.0.0.1:2823 connected to the server.

4/1/2008 11:05:17 PM > Computer at: UPRN013958710 requested the sensor list

4/1/2008 11:05:48 PM > Clean Data logged into DB for sensor: PVSensor1

4/1/2008 11:05:48 PM > Data logged into DB for sensor: PVSensor1

4/1/2008 11:05:50 PM > Computer at: UPRN013958710 requested data from PVSensor1

4/1/2008 11:06:18 PM > 127.0.0.1:2823 has disconnected from the server.

|
```

## Appendix N: Onsite Security Devices

These sensing systems may be used in a variety of different locations which have different levels of user traffic. For those areas where security can be a concern we have looked into various devices which all for the laptop to be safely secured while at the site.

### Wall-Mount Laptop Security Cabinet

**Cost:** 50 GBP

**Retailer:** Global Industrial (US)



**Comments:** This device is easily securable with a digital code required to open it. It is made of steel and wall mountable and has straps that hold the laptop in place. On both sides are 1.5" diameter holes that allow for cord connections. The Laptop cabinet measures 19-3/4"W x 4-3/4"D x 15-3/4"H.

**Website:**

<http://www.globalindustrial.com/gcs/product/productInfo.web?infoParam.mode=1&infoParam.itemKey=30135805>

**Moveable Laptop Arm w/ Extended**

**Wall Mount**

**Cost:** 130 GBP

**Retailer:** Desks4Computers (US)



**Comments:** This holds your laptop or securely on any wall or vertical surface on a metal platform sized 15" x 12". Extended wall mount arm reaches either 11 3/8" or 19 1/4" from the wall and swings side to side 180° out of your way. It can tilt 15° up or 25° down and the cables can be wired through the extendable arm.

**Website:**

[http://www.desks4computers.com/Merchant2/merchant.mvc?Screen=PROD&Store\\_Code=D&Product\\_Code=03-MON7021&Category\\_Code=LTA](http://www.desks4computers.com/Merchant2/merchant.mvc?Screen=PROD&Store_Code=D&Product_Code=03-MON7021&Category_Code=LTA)



### **6u 390mm Deep Data Cabinet/Data Rack**

**Cost:** 94 GBP

**Retailer:** Comms Express (UK)



**Comments:** This is a standard Data Cabinet used for storing various servers. It is adaptable to the use for storing a laptop or a sensing device. It is securable with a key lock, and has holes for wires to be wired into and out of the devices. It is steel and wall mountable. It also has a clear glass door for easy monitoring.

**Website:** <http://www.comms-express.com/pd-1045067779.htm?categoryId=68>

### **Kendall Howard 8 U Security Wall Mount Cabinet**

**Cost:** 170 GBP

**Retailer:** Kendall Howard (US)



**Comments:** A larger wall mountable cabinet. It can be used for laptop or sensor. It is wall mountable and can support up to 250 lbs. It has apertures for large number of cables as well as fans to cool the device. Has a lockable clear glass door for security and monitoring

**Website:** <http://cableorganizer.com/computer-cabinets/kh-security-cabinet.html>

## **Appendix O: How to use the Remote Requesting Application**

The Remote Requesting Application (RRA) was written by Nathan Roy as part of the Merton Rule Monitoring System (MRMS) prototype system, with some code examples used from the team who developed MrHomer for the previous project. The main purpose of the RRA is to serve as a proof of concept that a remote program can connect to the Onsite Server program and request sensor data in real-time. This guide will provide a walkthrough of what the program is doing during various important activities.

Once the RRA has been installed as explained in Appendix L you can start the RRA by double clicking on “Remote Requesting Application.exe” in your installation directory.

Once started, the program logs information when specific events occur during the execution as well as provide the user with ways to retrieve data from computers running the Onsite Server program. Upon starting the program, it will perform some initialization tasks, when complete it will prompt the user to connect to a computer:

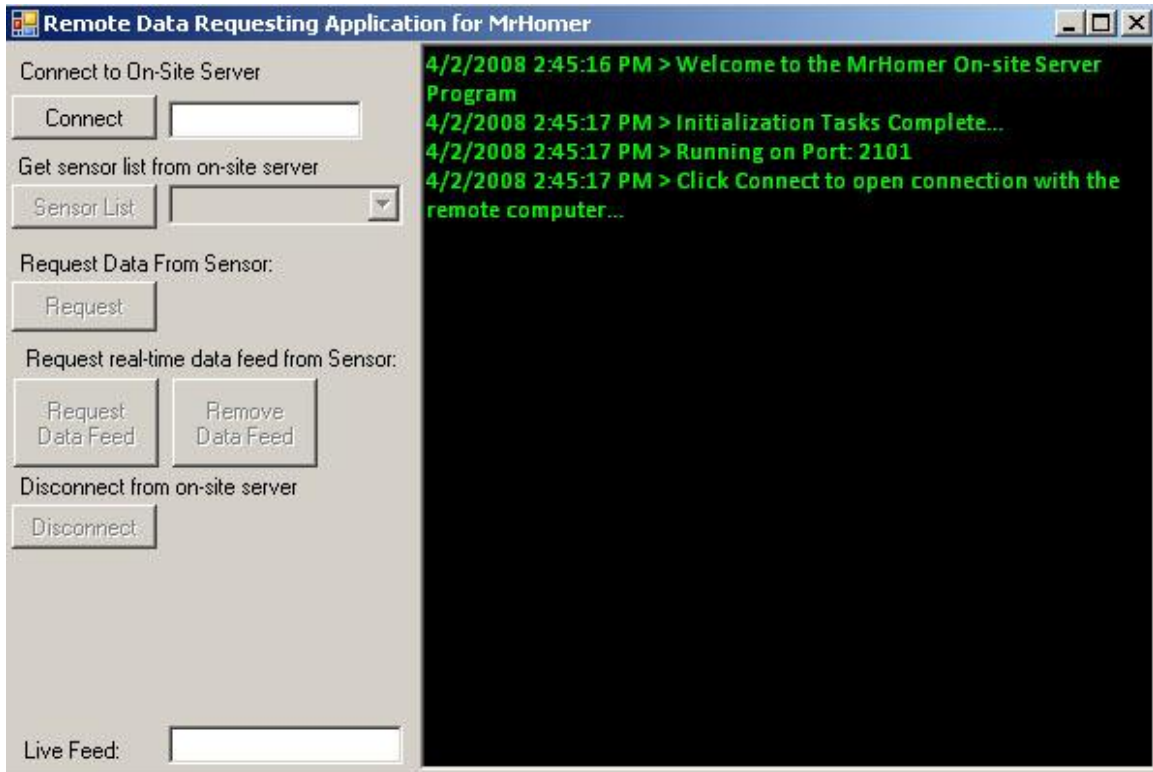

To begin a connection, enter in the IP address of the remote computer next to the “Connect” button and click “Connect”. Once connected, the program will print the message “Connected!”:

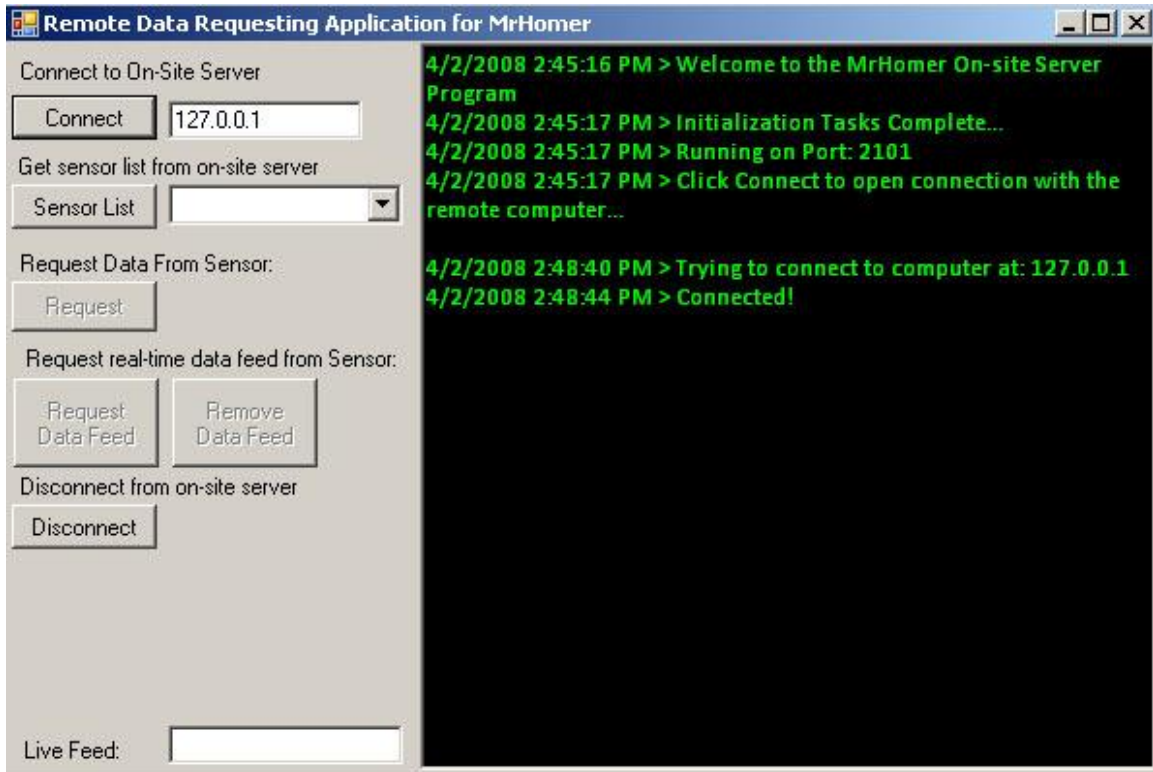

If the remote computer does not respond to the connection attempt within a certain time limit (the timeout period), the program will print the message “Could not connect to remote computer, connection timed out” and stop trying to connect:

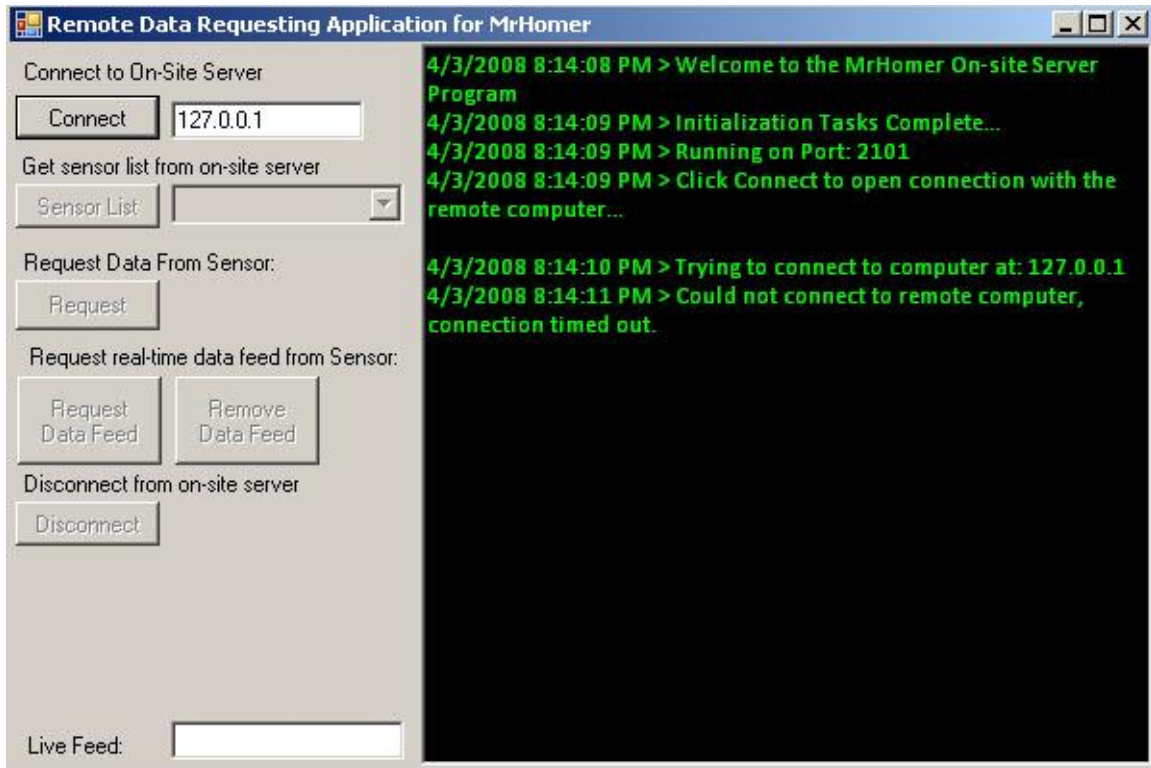

Once connected to the computer running the Onsite Server program, you must now request the list of sensors the server is monitoring. You do this by clicking the “Sensor List” button:

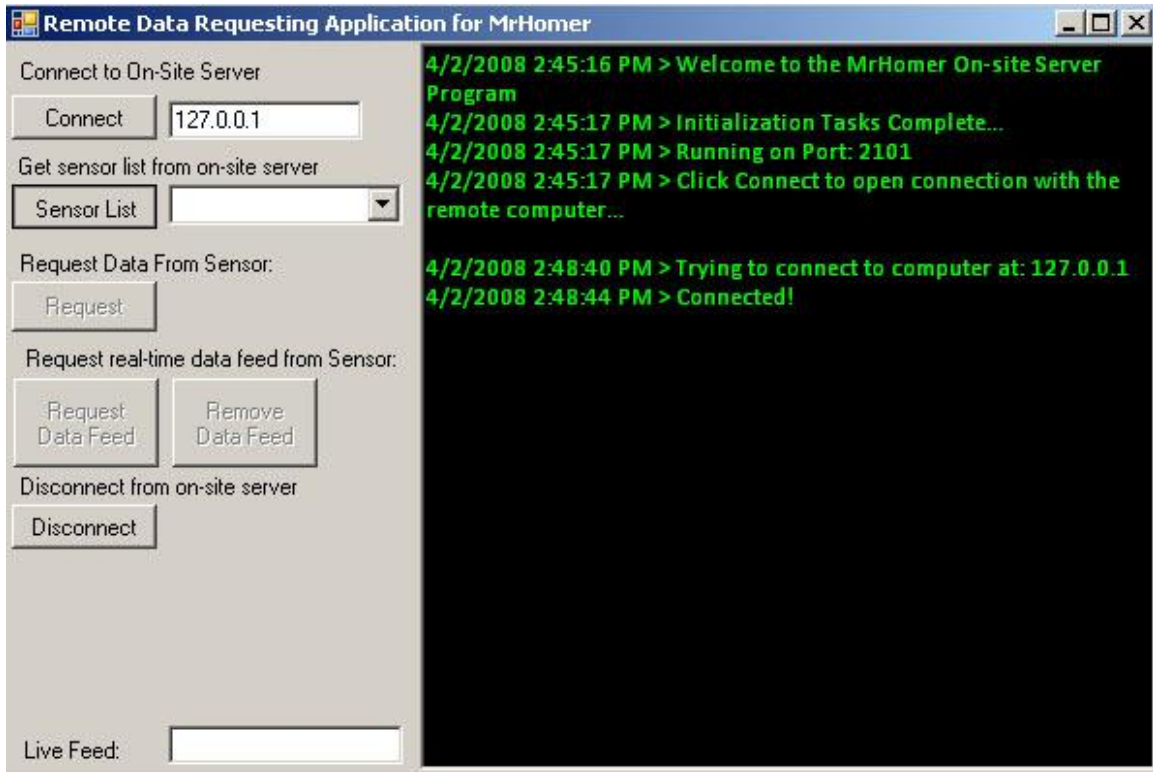

Upon receipt of the sensor list, the list box next to the “Sensor List” button will contain the list of available sensors. From the drop down, you can select the sensor you are most interested in:

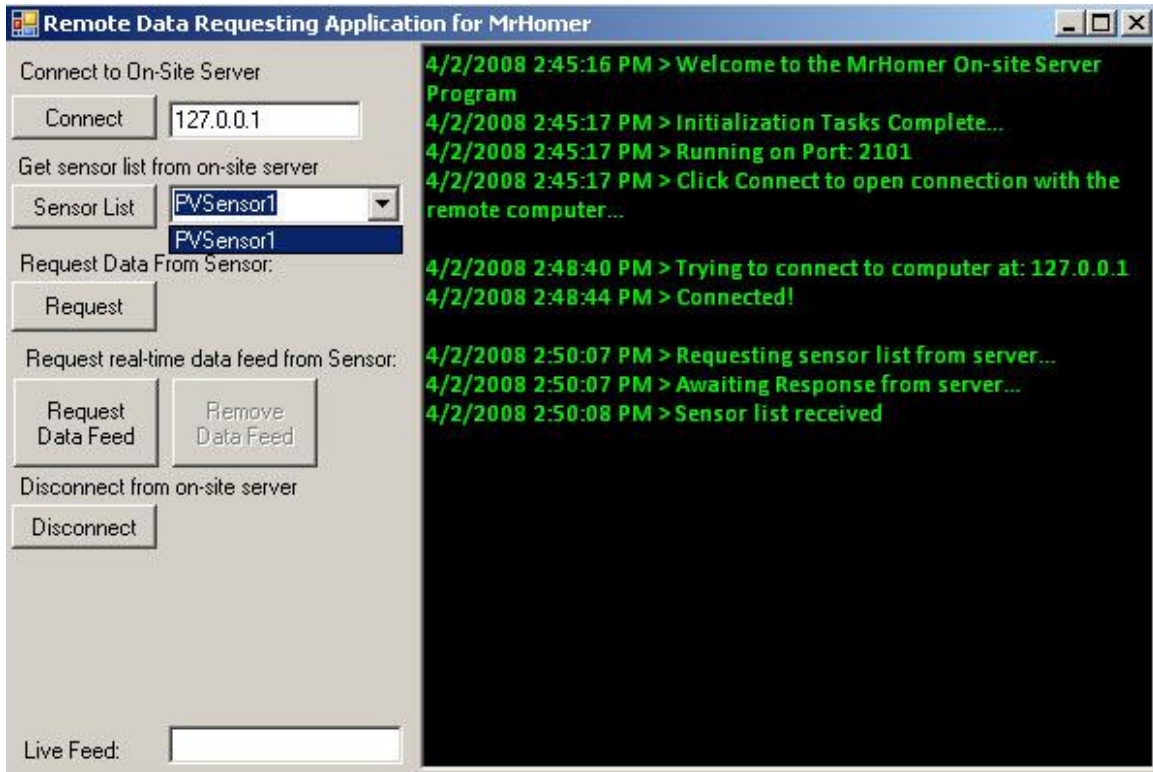

Once you have chosen a sensor, you can do one of two actions to retrieve data from the sensor:

The first is to just request the latest reading from the sensor. To do this, click the “Request” button and the most recent data will be printed out in the console to the right:



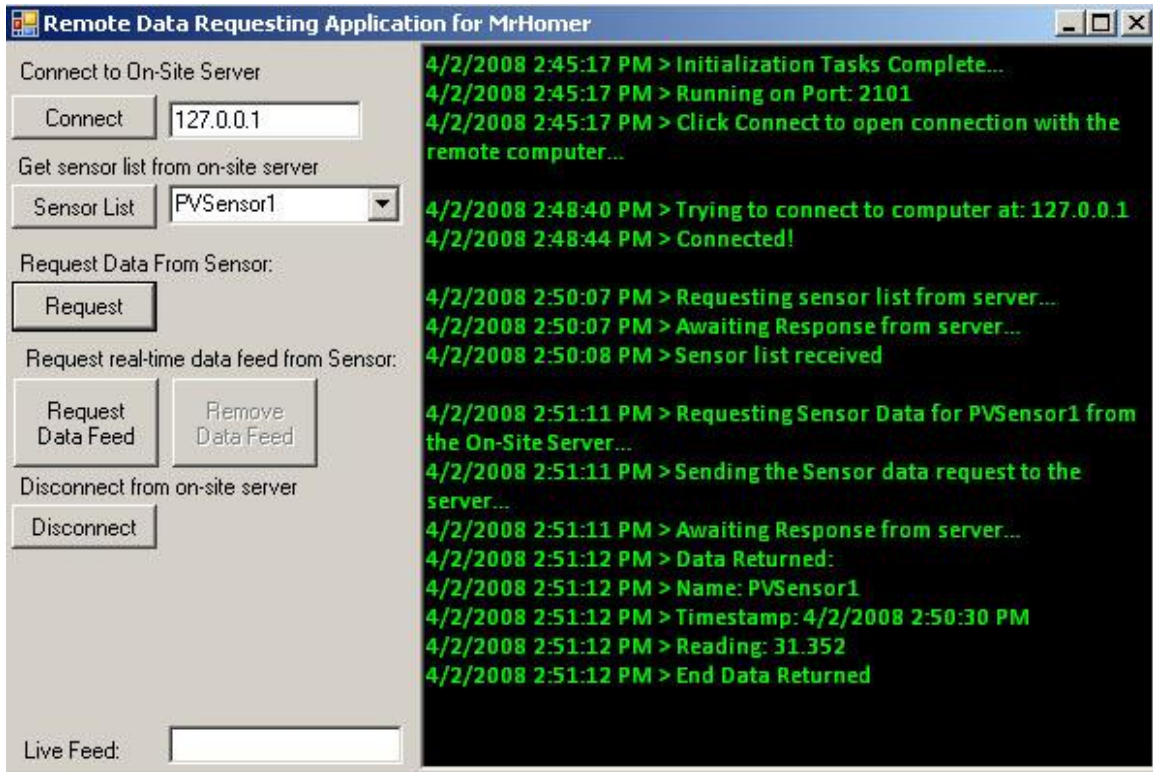

The other action you can do is to request a real-time data feed from the selected sensor. This will provide you with a new reading once per second in the “Live Feed” box in the bottom left of the application:

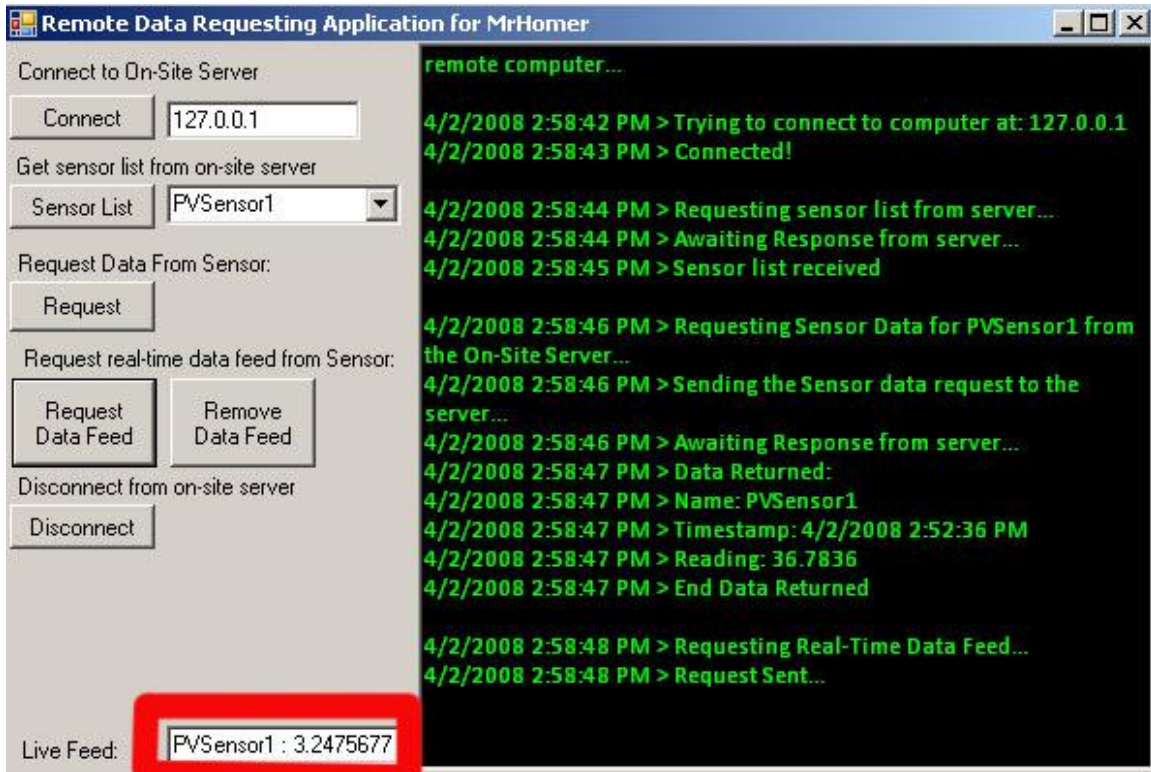

The final action that you can take using the Remote Requesting Application is to Disconnect from the Onsite Server computer. To do this, simply click the “Disconnect” button and once the disconnect is complete, “Now Disconnected!” will print to the screen:

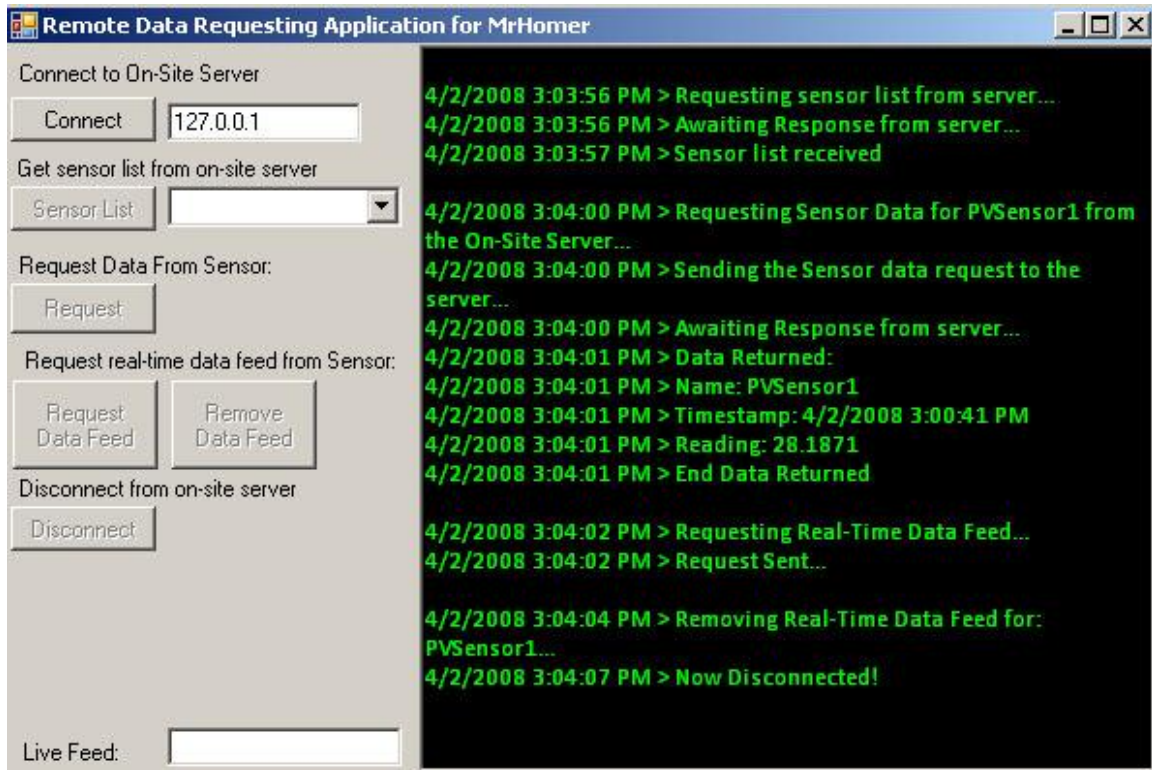

## **Appendix P: List of Contacts**

Dr Daniel Davies

Solar Century Chief Technology Officer (For questions about panels and sensors)

daniel.davies@solarcentury.com

m: +44 7733 046462

dd: +44 207 8030129

Robert Stoetter

meteocontrol contact (For questions about meteocontrol sensor and weblog)

phone +49-(0)-821-34666-32

email r.stoetter@meteocontrol.de

John Jimenez

Big Yellow Construction Manager (for visits)

T: 07764225944

Phil Jones

Big Yellow Networking (for internet issues)

Mobile: 07707 419 791

Email: phil.jones@excellgroup.com

Nigel Hartley

Big Yellow Construction Director

E: nhartley@bigyellow.co.uk

T: 01276 477832

F: 01276 477835

M: 07881 922855

## Appendix Q: How to write plug-ins for the MRMS

This appendix details how to write a sensor plug-in for the MrHomer framework used by the Merton Rule Monitoring System (MRMS). This appendix is meant for technical people, only obscure topics will be explained.

1. In Visual Studio, right click on the project you wish to have the file in and select Add > New Item...
2. In the Dialog Box select C# Class, and name it how you like. I named it TestSensor, and from here on, replace TestSensor with your chosen name.

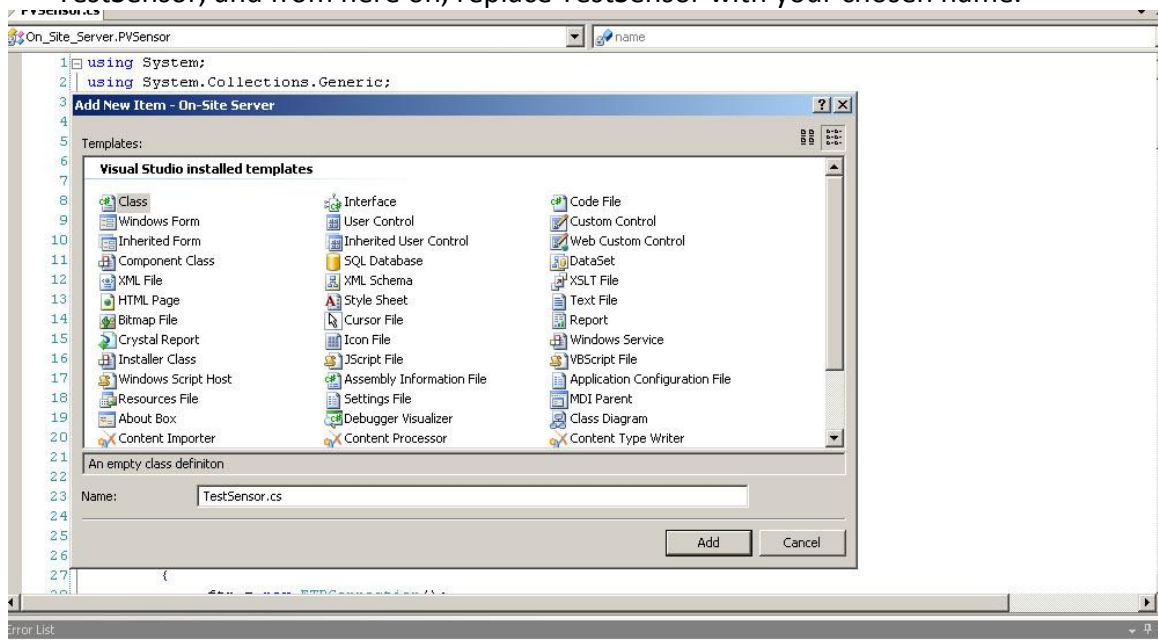

3. In the newly generated file, you must make the new class extend the Interface DuffBeer.Sensors.Interfaces.ISensor. To do this, make your class definition look like:

```
class TestSensor : ISensor  
{  
  
}
```

- At this point, if ISensor is not written in black text, move to the next step. Otherwise, ISensor needs to be resolved to a type. To do this, right click on the ISensor text and select Resolve > using DuffBeer.Sensors.Interfaces;

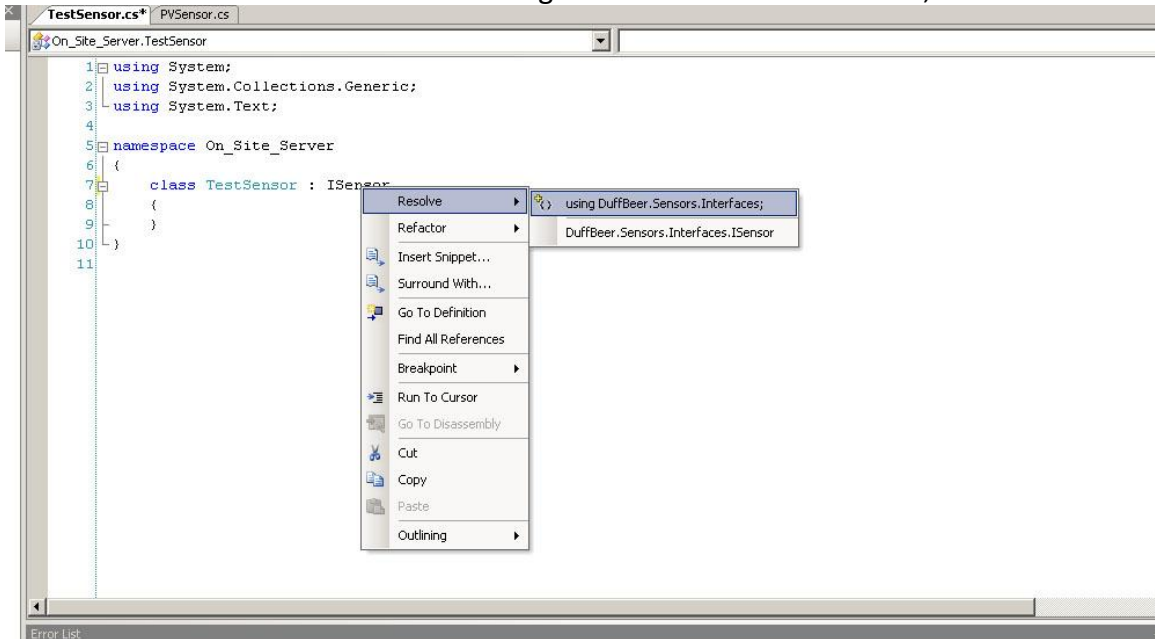

- Next, right click on the ISensor text and select Implement Interface > Implement Interface. This will auto generate code to implement the ISensor Interface.

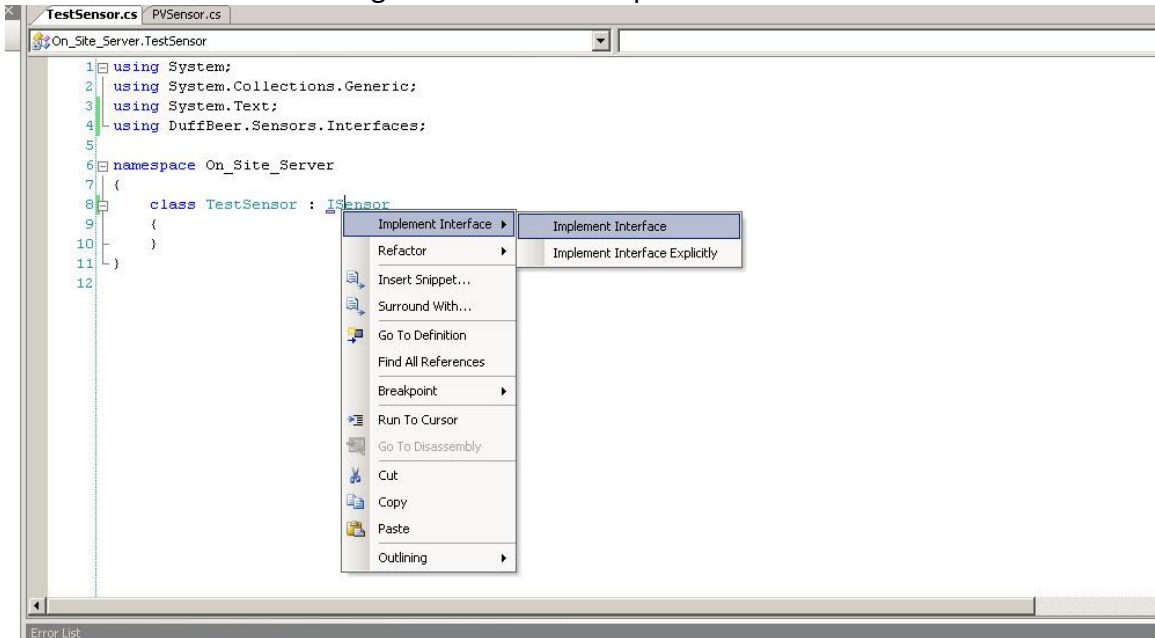

- Now your file has stub methods for all of the ISensor and IPlugin methods and variables. The list of methods and their explanations are below:

`#region ISensor Members`

`public object` RequestData() - This method is called each time the sensor refreshes. It gets a data reading from the sensor.

`public string` GetUnits() - This returns a string representation of what units are being used in this sensor (EX: KWH).

`public void` SetName(`string` name) - This method sets the name of the sensor.

`public byte[]` SerializeConfiguration() - This method is called when the system is serialized to the disk, use it to create a byte representation of the sensor.

`public void` DeserializeConfiguration(`byte[]` data) - This method is called whenever the system is being deserialized from the hard disk. Use it to populate the sensor with the necessary information for execution read from the byte array.

`public Type` ReturnType - This is the type that that sensor's RequestData() method returns.

`#endregion`

`#region IPlugin Members`



`public string` Author - This property is just who wrote the sensor code.

`public string` Version - This property is the sensor plug-in's code version.

`public string` Label - This property is basically a short description of the plug-in.

`#endregion`

---

7. Next add these lines of code to the class definition (right above `class TestSensor : ISensor` in your code) of your plugin:
- 

```
[MrHomerPlugin("Name", "Test Sensor")]  
[MrHomerPlugin("Make", "Test Company")]  
[MrHomerPlugin("Model", "Test 01")]  
[MrHomerPlugin("Description", "Test Sensor for Showing how to  
write plug-ins")]
```

---

These are the MrHomerAttributes that are required by the system to provide a description of the plug-in. For each of these entries, replace the second string with a value appropriate for your sensor.

8. If the MrHomerPlugin text is not written in black, continue to the next step. Otherwise, right click on the MrHomerPlugin text and select Resolve > using MrHomer.Plugins;

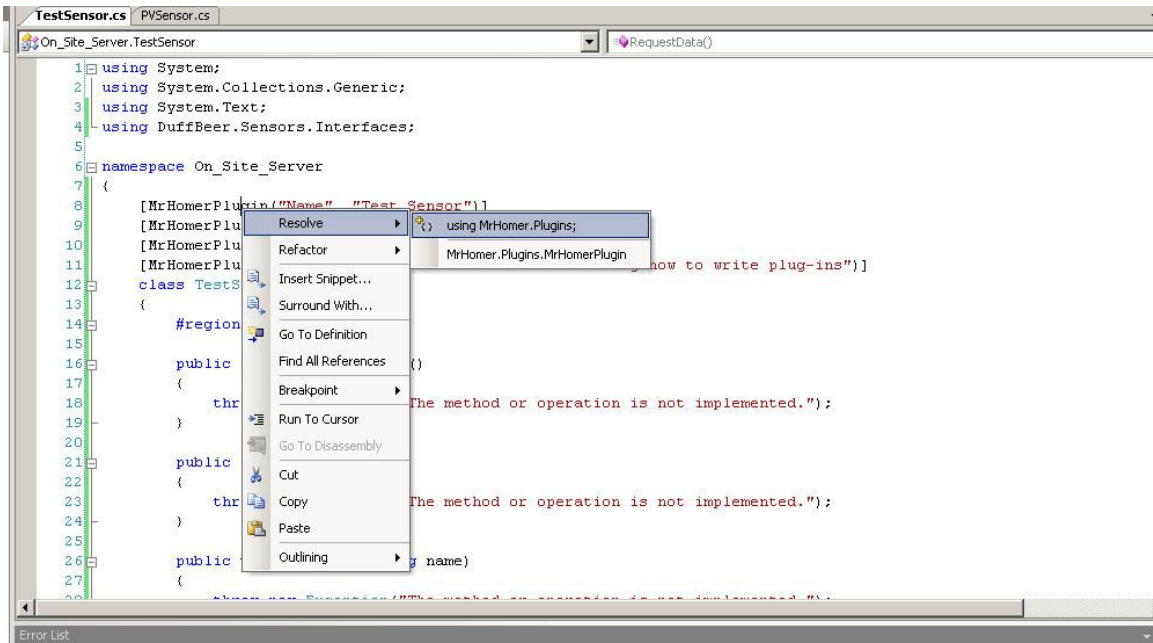

9. Now we can get to write the actual code of the test sensor. Here is a sample implementation of what a sensor plug-in can look like:

```

using System;

using System.Collections.Generic;

using System.Text;

using DuffBeer.Sensors.Interfaces;

using MrHomer.Plugins;

namespace On_Site_Server
{
    [MrHomerPlugin("Name", "Test Sensor")]
    [MrHomerPlugin("Make", "Test Company")]
    [MrHomerPlugin("Model", "Test 01")]
    [MrHomerPlugin("Description", "Test Sensor for Showing how to write
plug-ins")]
    class TestSensor : ISensor
    {

```

```
#region Variables

private string name;

#endregion

#region ISensor Members

public object RequestData()
{
    return new Random().NextDouble() * 10;
}

public string GetUnits()
{
    return "KwH";
}

public void SetName(string name)
{
    this.name = name;
}

public byte[] SerializeConfiguration()
{
    return (new UTF8Encoding()).GetBytes(name);
}
```

```
public void DeserializeConfiguration(byte[] data)
{
    name = (new UTF8Encoding()).GetString(data);
}

public Type ReturnType
{
    get { return typeof(Double); }
}

#endregion

#region IPlugin Members

public string Author
{
    get { return "Nathan Roy"; }
}

public string Version
{
    get { return "0.1"; }
}

public string Label
{
    get { return name; }
}
```

```
#endregion  
  
}  
  
}
```

---

Now you have a sensor plug-in which can be instantiated in the MRMS. The next steps show how to instantiate a sensor in the Onsite Server code. However, if you want to do anything with the data retrieved from the sensor, you must install a DataFilter on it first. Next we will write a DataFilter class implementation:

10. Add a new file to the project and name it whatever you'd like, I named mine TestFilter.

11. Now, like in the Sensor code, make the TestFilter class extend IDataFilter. Your class definition should now look like:

```
class TestFilter : IDataFilter
```

12. Now if the IDataFilter is written in black text, skip to the next step. Otherwise, right click on the IDataFilter text and select resolve > using DuffBeer.Sensors.Interfaces;

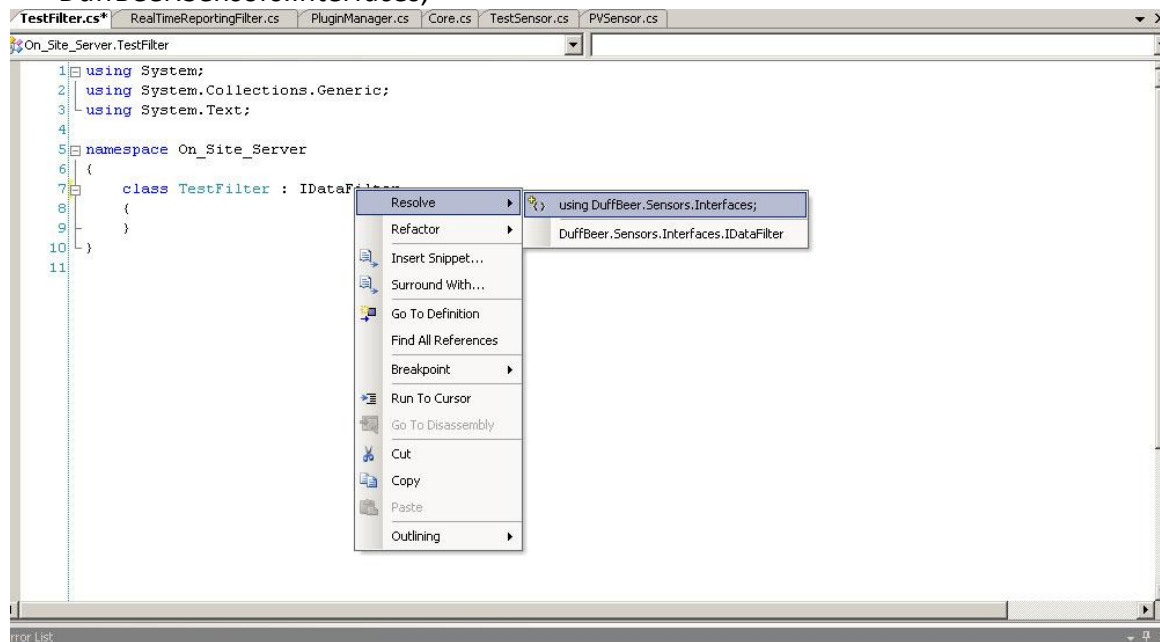

13. Next, right click on the IDataFilter text and select Implement Interface > Implement Interface. This will auto generate code to implement the IDataFilter Interface.

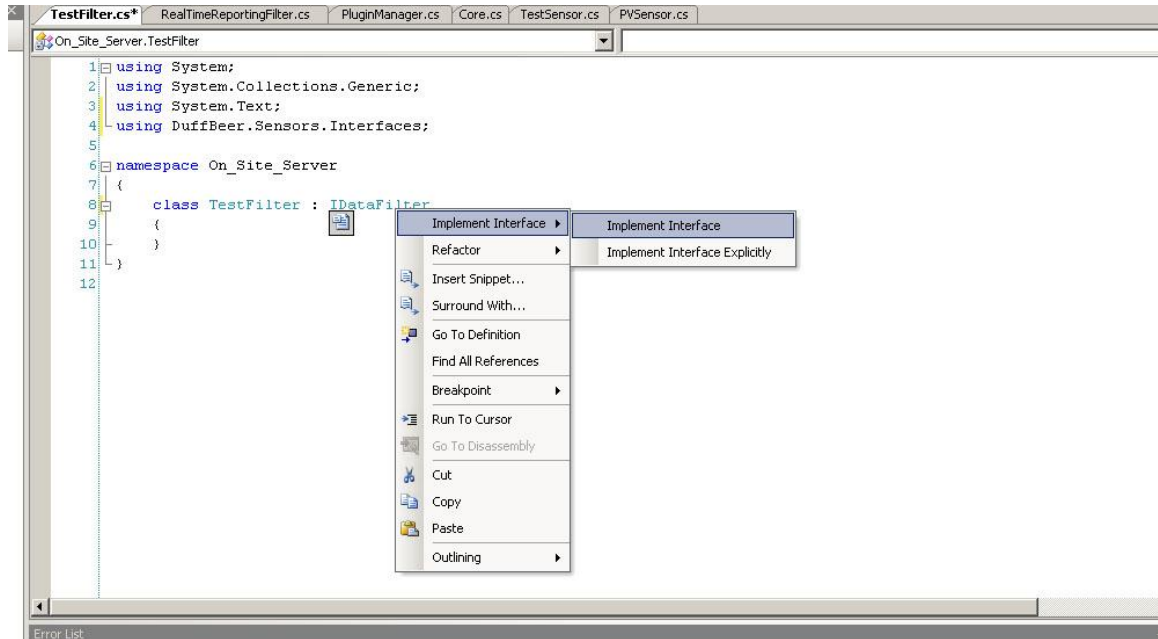

14. Now your file has stub methods for all of the IDataFilter and IPlugin methods and variables. The list of methods and their explanations are below:

```
#region IDataFilter Members
```

```
public object Filter(object data) - This is where the data is actually filtered, this is where your code will go that does something with the data, like log it into a database.
```

```
public byte[] SerializeConfiguration() - This method is the same as above.
```

```
public void DeserializeConfiguration(byte[] data) - This Method is the same as above.
```

`public Type InputType` - This is the type that the datafilter expects to filter.

`public Type OutputType` - This is the type of data that the filter outputs.

`public int DBID` - This is the Database id, only use if logging to a Database.

```
{  
    get  
  
    set  
}  
}
```

`public DuffBeer.Sensors.Sensor associatedSensor` - This is the sensor that this filter instance is attached to. This is not a necessary field.

```
{  
    get  
  
    set  
}
```

`#endregion`

`#region IPlugin Members`

```
public string Author - This is the same as above
```

```
public string Version - This is the same as above
```

```
public string Label - This is the same as above
```

```
#endregion
```

---

15. Next add these lines of code to the class definition (right above `class TestFilter : IDataFilter`your code) of your plugin:

---

```
[MrHomerPlugin("Name", "Test Data Filter")]  
[MrHomerPlugin("Description", "Does nothing much with the  
data")]
```

---

These are the `MrHomerAttributes` that are required by the system to provide a description of the plug-in. For each of these entries, replace the second string with a value appropriate for your filter.

16. If the `MrHomerPlugin` text is not written in black, continue to the next step. Otherwise, right click on the `MrHomerPlugin` text and select `Resolve > using MrHomer.Plugins`;
  17. Now we can get to the code of the test filter, here is an example of what the `datafilter` can look like:
- 

```
using System;  
using System.Collections.Generic;  
using System.Text;
```



```

using DuffBeer.Sensors.Interfaces;

using System.IO;

using MrHomer.Plugins;

namespace On_Site_Server
{
    [MrHomerPlugin("Name", "Test Data Filter")]
    [MrHomerPlugin("Description", "Does nothing much with the data")]
    class TestFilter : IDataFilter
    {
        #region IDataFilter Members

        public object Filter(object data)
        {
            Double d = (double)data;

            //write this data to a file
            FileStream file = new FileStream("test.txt",
            FileMode.Append, FileAccess.Write);

            StreamWriter sw = new StreamWriter(file,
            UTF8Encoding.UTF8);

            sw.WriteLine(d);

            sw.Close();
            file.Close();

            return d;
        }
    }
}

```

```
}

public byte[] SerializeConfiguration()
{
    return new byte[] { 1, 1 };
}

public void DeserializeConfiguration(byte[] data)
{
}

public Type InputType
{
    get { return typeof(Double); }
}

public Type OutputType
{
    get { return typeof(Double); }
}

public int DBID
{
    get
    {
```

```

        throw new Exception("The method or operation is not
implemented.");
    }
    set
    {
        throw new Exception("The method or operation is not
implemented.");
    }
}

public DuffBeer.Sensors.Sensor associatedSensor
{
    get
    {
        return null;
    }
    set
    {
        ;
    }
}

#endregion

#region IPlugin Members

public string Author
{
    get { return "Nathan Roy"; }
}

```

```

    }

    public string Version
    {
        get { return "V 0.1"; }
    }

    public string Label
    {
        get { return "Test Data Filter"; }
    }

    #endregion
}
}

```

---

Now you have a datafilter class that you can install on your sensor. The last part in creating a test sensor and filter is to instantiate them in the Onsite Server Code:

18. In the On-Site Server project, open the Core.cs file.

19. In the Method

```
private static void performSensorStartup()
```

Add the following Code to the end of the method:

---

```

sm.InstantiateSensor("TestSensor1", "Fake", "Test Sensor", 1000);
sm.AddFilter("TestSensor1", "Test Filter 1", "Test Data Filter");
Log("Started TestSensor1 " + sm.StartSensor("TestSensor1"));

```

---

This will create a Sensor named "TestSensor1" of the type "Test Sensor" (The MrHomerPluginAttribute associated with the test sensor we created) with the refresh rate of 1000 ms. Next it adds your test filter onto the sensor "TestSensor1"

called “Test Filter 1”, with the type “Test Data Filter” (The MrHomerPluginAttribute associated with the test data filter we created)

20. Now you can run the Onsite Server Program. In the First few lines, the line “Started TestSensor1 True” should print.
21. Close the Onsite Server Program and navigate to your MrHomer\On-Site Server\bin\Debug\ directory and there will be a file named “test.txt” with your readings from your fake sensor in it.

You should now have all of the knowledge necessary to write sensor plugins for MRMS and MrHomer in general.

## Appendix R: Microcontrollers vs. USB

The goal is to get real-time data from a sensor to the Onsite Server running MrHomer. MrHomer communicates USB interface though a software plugin. Some sensors come with USB communication and some does not. Usually the ones that come with USB communication costs a lot more and could possibly cost more than the budget. Therefore, a solution might be necessary to address this.

One such solution is the use of a microcontroller to grab the data from the data pins of the sensors and feed the data through an RS232 device, and the RS232 device sends the data through the RS232 to USB converter. And finally the RS232 to USB converter will give the information to MrHomer through the USB port.

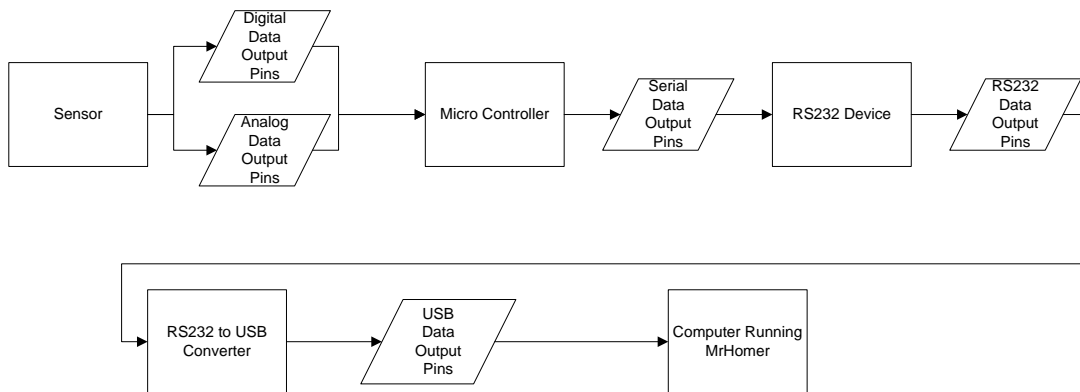
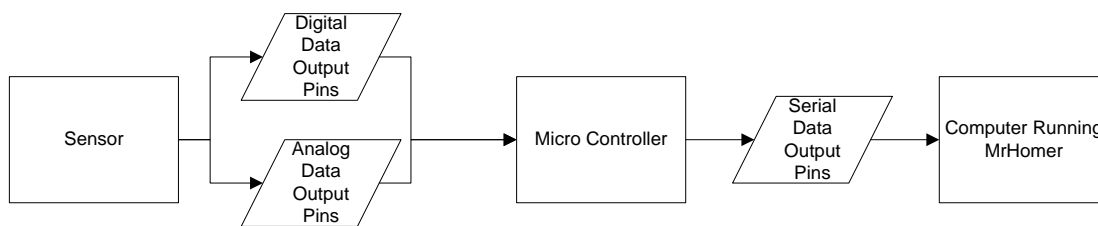

**Figure R-1: Cheapest Hardware with Minor Engineering**

A microcontroller is a device that has I/O (input/output) capabilities that can read and write analog and digital data. The reason for this consideration is that this device works for all types of sensors, even those that cost pennies. The microcontroller that we are using is the MSP430. We have created a layout program that includes the functions to read and write digital and analog data, and send and receive serial data. (Refer to the Microcontroller Code Section)

The RS232 device is a device that sends and receives serial data. The specific device that we are using is the MAX232. The reason for using this device is that it can connect the microcontroller to the laptop that is running MrHomer. MAX232 outputs to the RS232 port which most modern laptops do not have. That is why the RS232 to USB converter is also necessary.

Another hardware consideration that we have is connecting the microcontroller directly to the USB port of the laptop running MrHomer.

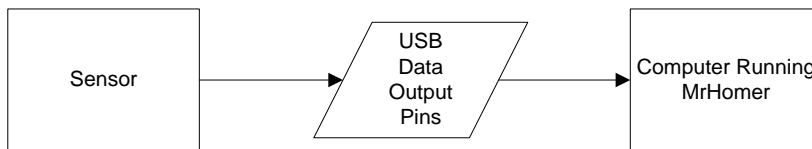

**Figure R-2: Simple Hardware but Requires Driver Writing**

Since the microcontroller can use serial output, this is feasible. However, we would need to break a USB memory stick for the connection pins and we'll have to

solder the output pins of the microcontroller to the connection pins of the connector that came from the USB stick. We do not have soldering iron and we will also need to write windows drivers for this second approach as well since there is no RS232 to USB converter to take care of it. Therefore, the second approach is avoided.

In conclusion, the use of a microcontroller is to handle the worst-case scenario, which is the case that we cannot find a USB output sensor that is measuring data in real time and is within the budget. If we are able to find a USB output sensor that is measuring data in real time and is within the budget, we can avoid this complicated hardware scheme and just focus on the MrHomer plugins. So the easiest approach, assuming that everything fits the constraints is a USB capable sensor attached to the USB port of a laptop that is running MrHomer.



**Figure R-3: Expensive Hardware but Easy Engineering**

As of now, we do not have an RS232 device with us nor do we have an RS232 to USB converter. It is possible to order them for less than \$50 total, but we hope that we can get a sensor with USB output that gives real time readings.

**Microcontroller Code (Used For Documentation Purposes):**



This code is a layout that is ready to compile and downloaded to the MSP430F2013 USB stick. The full functionality of the code has not yet been tested due to the lack of hardware. However, from testing the output pins with a digital multi-meter, we know that the code allows the microcontroller to send out serial data.

As of now, the code is sending serial data at 2400 bit/sec to port 1 pin 5 and receiving serial data at port 1 pin 1. The user just has to give an 8 bit value to the register (variable) RXTXData and microcontroller will transmit the desired data.

Functions such as analog to digital converter (ADCoN() and runADC()) and digital input and outputs are also created. ADCoN() tells the microcontroller to get ready to do analog to digital conversion and this function should go outside of the main loop. runADC() tells the microcontroller to start doing analog to digital conversion. This function should go inside the main loop. Analog to digital conversion is how the microcontroller reads analog data from the sensors. The reading is done on Port1 Pin1.

The digital input and output functions tell the microcontroller to read digital data and write digital data, respectively. For example, the function readPin2() tells the microcontroller to read the value of Port 1 Pin2. This function will return a 1 or 0. Therefore, if the sensor is giving out digital values, all we have to do is connect the sensor to that pin and we can grab that data. The function writePin2L() tells the microcontroller to output a digital 0 and the function writePin2H() tells the microcontroller to output a digital 1.

In conclusion, these functions on this layout will allow a microcontroller to read any type of data from the sensors and transmit the data to the computer running MrHomer.

### **The Code Layout:**

```
#include "msp430x20x2.h"

#define RXD    0x02        // RXD on P1.1
#define TXD    0x20        // TXD on P1.5

// Conditions for 2400 Baud SW UART, ACLK = 32768

#define Bitime_5 0x06        // ~ 0.5 bit length + small adjustment
#define Bitime   0x0E        // 427us bit length ~ 2341 baud

//Functions

void writePin0H(void);

void writePin0L(void);

int readPin0(void);

void writePin1H(void);
```

```
void writePin1L(void);
```

```
int readPin1(void);
```

```
void writePin2H(void);
```

```
void writePin2L(void);
```

```
int readPin2(void);
```

```
void writePin3H(void);
```

```
void writePin3L(void);
```

```
int readPin3(void);
```

```
void TimerAOn(void);
```

```
void stopTimeA(void);
```

```
void swDelay(int max_cnt);
```

```
void ADCoN(void);
```

```
int runADC(void);
```

```
unsigned int RXTXData;
```

```
unsigned char BitCnt;
```

```
void TX_Byte (void);
```

```
void RX_Ready (void);
```

```
// ADC10 interrupt service routine
```

```
#pragma vector=ADC10_VECTOR
```

```
__interrupt void ADC10_ISR(void)
```

```
{
```

```
    __bic_SR_register_on_exit(CPUOFF);    // Clear CPUOFF bit from 0(SR)
```

```
}
```

```
// Timer A0 interrupt service routine
```

```
#pragma vector=TIMERAO_VECTOR
```

```
__interrupt void Timer_A (void)
```

```
{
```

```
    CCR0 += Bitime;                // Add Offset to CCR0
```

```

// TX

if (CCTL0 & CCIS0)          // TX on CCI0B?
{
    if ( BitCnt == 0)

    CCTL0 &= ~ CCIE;        // All bits TXed, disable interrupt

else

{
    CCTL0 |= OUTMOD2;       // TX Space

    if (RXTXData & 0x01)

    CCTL0 &= ~ OUTMOD2;    // TX Mark

    RXTXData = RXTXData >> 1;

    BitCnt --;

}

}

// RX

else

{

    if( CCTL0 & CAP )      // Capture mode = start bit edge

    {

    CCTL0 &= ~ CAP;        // Switch from capture to compare mode

```



```

void main (void)
{
    WDTCTL = WDTPW + WDTHOLD;          // Stop watchdog timer

    CCTLO = OUT;                       // TXD Idle as Mark

    TACTL = TASSEL_1 + MC_2;          // ACLK, continuous mode

    P1SEL = TXD + RXD;                //

    P1DIR = TXD;                      //

//ADCoN();

// Mainloop

for (;;)
{
    //runADC();

    RX_Ready();                       // UART ready to RX one Byte

    _BIS_SR(LPM3_bits + GIE);        // Enter LPM3 w/ interr until char RXed

//RXTXData = 0xEA; //Note that 0xEA is a random 8 bit data

```

```

TX_Byte());          // TX Back RXed Byte Received
}
}

```

```

// Function Transmits Character from RXTXData Buffer

```

```

void TX_Byte (void)
{
    BitCnt = 0xA;          // Load Bit counter, 8data + ST/SP
    while (CCR0 != TAR)    // Prevent async capture
        CCR0 = TAR;       // Current state of TA counter
    CCR0 += Bitime;       // Some time till first bit
    RXTXData |= 0x100;    // Add mark stop bit to RXTXData
    RXTXData = RXTXData << 1; // Add space start bit
    CCTLO = CCIS0 + OUTMOD0 + CCIE; // TXD = mark = idle
    while ( CCTLO & CCIE ); // Wait for TX completion
}

```

```

// Function Readies UART to Receive Character into RXTXData Buffer

```

```

void RX_Ready (void)

```



```

{
    BitCnt = 0x8;           // Load Bit counter

    CCTLO = SCS + OUTMOD0 + CM1 + CAP + CCIE; // Sync, Neg Edge, Cap
}

void ADCoN(){
    ADC10CTL0 = ADC10SHT_2 + ADC10ON + ADC10IE; // ADC10ON, interrupt enabled

    ADC10CTL1 = INCH_1;      // input A1

    ADC10AE0 |= 0x02;       // PA.1 ADC option select

    P1DIR |= 0x01;         // Set P1.0 to output direction
}

int runADC(){
    ADC10CTL0 |= ENC + ADC10SC; // Sampling and conversion start

    __bis_SR_register(CPUOFF + GIE); // LPM0, ADC10_ISR will force exit

    if (ADC10MEM < 0x1FF)
        P1OUT &= ~0x01;      // Clear P1.0 LED off
    else
        P1OUT |= 0x01;       // Set P1.0 LED on
}

```

```

return ADC10MEM;

}

//Timer Functions

void TimerAOn(){

    TACCTL0 = CCIE;           // CCR0 interrupt enabled

    TACCR0 = 327.68; //32768

    TACTL = TASSEL_1 + ID_0+MC_1;      // ACLK, upmode

}

/***** stopTimer() *****/

void stopTimer(){

    TACTL = MC_0; // stop timer

    TACCTL0 &= ~CCIE; // TBCCR0 interrupt disabled

}

//-----

```

```
//I/O FUNCTIONS FOR PORT 1: PIN 1 TO PIN 3 (NOTE: PIN 0 is grounded)
```

```
void writePin0H()
```

```
{
```

```
    P1SEL = !(BIT0);
```

```
    P1DIR = (BIT0);
```

```
    P1OUT = (BIT0);
```

```
}
```

```
void writePin0L()
```

```
{
```

```
    P1SEL = !(BIT0);
```

```
    P1DIR = (BIT0);
```

```
    P1OUT = !(BIT0);
```

```
}
```

```
//DONT USE THIS PIN0 is GROUNDED
```

```
int readPin0()
```

```
{
```

```
    P1SEL = !(BIT0);
```

```
    P1DIR = !(BIT0);
```

```
    return P1IN;  
}
```

```
void writePin1H()  
{  
    P1SEL = !(BIT1);  
    P1DIR = (BIT1);  
    P1OUT = (BIT1);  
}
```

```
void writePin1L()  
{  
    P1SEL = !(BIT1);  
    P1DIR = (BIT1);  
    P1OUT = !(BIT1);  
}
```

```
int readPin1()  
{  
    P1SEL = !(BIT1);
```

```
P1DIR = !(BIT1);  
  
return (P1IN & 2)/2;  
  
}
```

```
void writePin2H()  
  
{  
  
    P1SEL = !(BIT2);  
  
    P1DIR = (BIT2);  
  
    P1OUT = (BIT2);  
  
}
```

```
void writePin2L()  
  
{  
  
    P1SEL = !(BIT2);  
  
    P1DIR = (BIT2);  
  
    P1OUT = !(BIT2);  
  
}
```

```
int readPin2()  
  
{
```

```
P1SEL = !(BIT2);  
  
P1DIR = !(BIT2);  
  
return (P1IN & 4)/4;  
  
}
```

```
void writePin3H()  
  
{  
  
    P1SEL = !(BIT3);  
  
    P1DIR = (BIT3);  
  
    P1OUT = (BIT3);  
  
}
```

```
void writePin3L()  
  
{  
  
    P1SEL = !(BIT3);  
  
    P1DIR = (BIT3);  
  
    P1OUT = !(BIT3);  
  
}
```

```
int readPin3()  
  
{
```

```
P1SEL = !(BIT3);

P1DIR = !(BIT3);

return (P1IN & 8)/8;

}

//-----

/***** swDelay() *****/

void swDelay(int max_cnt)

{

    unsigned int cnt1=0;

    while (cnt1 < max_cnt)

        cnt1++;

}
```

## References

- Bernard, R., Lessard, B., O'Keefe B., Scalabrini C. (2008). On the Feasibility of an Energy Reporting System in London. Retrieved 2008 from C Term IQP Group.
- Budget 2007-2008. (n.d.). Retrieved February 17, 2008, from London Borough of Merton Web site: [http://www.merton.gov.uk/budget\\_book\\_0708\\_v2.pdf](http://www.merton.gov.uk/budget_book_0708_v2.pdf)
- Burgess, A., Keay, D., Spanos, R., Topi, J. (2005). *City Knowledge and Municipal Data Infrastructure*. Retrieved 2008 from D Term IQP Group.
- Carrera, F. (2004). City Knowledge: An emergent information infrastructure for sustainable urban maintenance, management and planning. (Doctoral dissertation, Massachusetts Institute of Technology, 2004). Retrieved from <<http://users.wpi.edu/~carrera/MIT/dissertation.html>>.
- Carrera, F. (2005). In *Proceedings of the First International Conference of the Management of Urban Maintenance: Growing the Tree of Knowledge: extracting informational returns from the maintenance of trees in Cambridge, Massachusetts*. Venice, Italy. 4. Retrieved from <[http://ece.wpi.edu/CityLab/Publications/Conferences/Growing\\_the\\_Tree\\_of\\_Knowledge.doc](http://ece.wpi.edu/CityLab/Publications/Conferences/Growing_the_Tree_of_Knowledge.doc)>.
- Carrera, F., & Ferreira, J. (2007). The Future of Spatial Data Infrastructures: Capacity-building for the Emergence of Municipal SDIs. *International Journal of Spatial Data Infrastructures Research*. Retrieved 2008 from



- <<http://ece.wpi.edu/CityLab/Publications/Journals/IJSDIR-07-Carrera-Ferreira.pdf>>.
- Carrera, F., & Hewitt, A. (2006). In *Proceedings of the 25<sup>th</sup> Urban data Management Symposium: The Premises of City Knowledge: a middle-out approach toward sustainable municipal data management*. Aalborg, Denmark., 5-15. Retrieved from <<http://www.udms.net/html/AALBORG2006/AALBORG2006.lasso>>.
- Carrera, F., & Hoyt, L. (2006). From Plan-Demanded Data to Plan-Ready Information: A Rationale for Comprehensive Urban Knowledge Infrastructures. *Journal of Urban Technology*. 13(2). 3-23. Retrieved from <<http://www.tandf.co.uk/journals/titles/10630732.asp>>.
- Carrera, Fabio. *CityLab @ WPI*. Retrieved January 27, 2008, from *Worcester Polytechnic Institute, Electrical and Computer Engineering Web site*, [http://ece.wpi.edu/CityLab/City\\_Lab.html](http://ece.wpi.edu/CityLab/City_Lab.html)
- Carrera, Fabio. *LOUIS @ CityLab*. Retrieved January 27, 2008, from *Worcester Polytechnic Institute, Electrical and Computer Engineering Web site*, <<http://ece.wpi.edu/CityLab/UIS/Louis/Louis.html>>
- Carrera, Fabio. *Urban Information Systems @ CityLab*. Retrieved January 27, 2008, from *Worcester Polytechnic Institute, Electrical and Computer Engineering Web site*, [http://ece.wpi.edu/CityLab/UIS/Urban\\_Information\\_Systems.html](http://ece.wpi.edu/CityLab/UIS/Urban_Information_Systems.html)
- DeMello, J., Guzman, J., Luk, C., & Robert, M. A. (2006). *Carbon Reduction Tools for Municipal Building*. Retrieved 2008 from E Term IQP Group.

- Durkin, Martin (2007). *The Great Global Warming Swindle*. British: Channel 4.
- Economics Group, Defra. (2007, December). *The Social Cost Of Carbon And The Shadow Price Of Carbon: What They Are, And How To Use Them In Economic Appraisal In The UK*. Retrieved April 3, 2008, from Department for Environment, Food and Rural Affairs Web site: <http://www.defra.gov.uk>
- Energy Detective, The (2008). T.E.D.: Electricity Monitor, Energy Monitor, Power Monitor. Retrieved March, 2008, from <http://www.theenergydetective.com/>
- Energy Information Administration (EIA). (2004, April 2). *Greenhouse Gases, Climate Change, and Energy*. Retrieved February 13, 2008, from <http://www.eia.doe.gov/oiaf/1605/ggccebro/chapter1.html>
- Energy Saving Trust, The. (2008). *Ground source heat pumps - Heat pumps & ground loops*. Retrieved March 24, 2008, from The Energy Saving Trust Web Site: [http://www.energysavingtrust.org.uk/generate\\_your\\_own\\_energy/types\\_of\\_renewables/ground\\_source\\_heat\\_pumps](http://www.energysavingtrust.org.uk/generate_your_own_energy/types_of_renewables/ground_source_heat_pumps)
- European Climate Exchange*. (2008.). Retrieved April 3, 2008, from [http://www.europeanclimateexchange.com/default\\_flash.asp](http://www.europeanclimateexchange.com/default_flash.asp)
- Gore, Al (2006). *An Inconvenient Truth*. Unknown: Rodale Press.
- Greater London Authority. (2007, February). *Action Today to Protect Tomorrow: The Mayor's Climate Change Action Plan*. Retrieved April, 2008, from <http://www.london.gov.uk/mayor/environment/climate-change/ccap/index.jsp>

Hays, William (2002). BH Electronics, Marshall, Minn. Retrieved April 13, 2006, from Exploring Current Transformer Applications from Web site:

[http://powerelectronics.com/mag/power\\_exploring\\_current\\_transformer/](http://powerelectronics.com/mag/power_exploring_current_transformer/)

Hewitt, A. (2006). *The Merton Rule 10% policy* (Policy briefing) London Borough of Merton.

Hewitt, A. (2006). *The Merton Rule 10% policy* (Policy briefing) London Borough of Merton.

History of Merton Thursday 26 April 2007. (n.d.). February 17, 2008, from London Borough of Merton Web site:

<http://www.merton.gov.uk/leisure/history/makingmerton.htm>

Information Control Office. (1998). Data Protection Act. Retrieved April 13, 2008, from Public Sector Information Web site:

[http://www.opsi.gov.uk/Acts/Acts1998/ukpga\\_19980029\\_en\\_1](http://www.opsi.gov.uk/Acts/Acts1998/ukpga_19980029_en_1)

IPCC (2007). IPCC Reports. Retrieved January 29, 2008, from IPCC - Intergovernmental Panel on Climate Change Web site: <http://www.ipcc.ch/ipccreports/index.html>.

Jones, Tony (2007). *ABC Australia's Tony Jones Dissects, Debunks Martin Durkin*.

Australia: ABC.

Kelly, H. (1978). *Photovoltaic Power Systems: A Tour Through the Alternatives*. Retrieved February 3, 2008, from JSTOR database (7): <http://links.jstor.org/sici?sici=0036-8075%2819780210%293%3A199%3A4329%3C634%3APPSATT%3E2.0.CO%3B2-1>

London Borough of Merton. (2007). *The 10% renewable energy policy (the Merton Rule)*.

Retrieved January 25, 2008, from

<http://www.merton.gov.uk/living/planning/plansandprojects/10percentpolicy.htm>

Low Carbon Buildings Program 2008. (n.d.). BERR: Department of Business Enterprise and Regulatory Reform. . Retrieved April 10, 2008, from

<http://www.lowcarbonbuildings.org.uk/info/installers/>

Merton Council. (2007, November 30). Council of Merton. In *Departments of Merton*.

Retrieved February 17, 2008, from London Borough of Merton database:

<http://www.merton.gov.uk/living/planning/planningpolicy.htm>

NASA. OHM'S LAW. Retrieved February 15, 2008, from National Aeronautics and Space

Administration Web site: <http://www.grc.nasa.gov/WWW/K->

[12/Sample\\_Projects/Ohms\\_Law/ohmslaw.html](http://www.grc.nasa.gov/WWW/K-12/Sample_Projects/Ohms_Law/ohmslaw.html)

NASA. Thermodynamics. Retrieved February 15, 2008, from National Aeronautics and

Space Administration Web site: <http://www.grc.nasa.gov/WWW/K->

[12/airplane/thermo1.html](http://www.grc.nasa.gov/WWW/K-12/airplane/thermo1.html)

National Energy Foundaton. (2007). *Simple Carbon Calculator*. Retrieved April 10, 2008,

from <http://www.nef.org.uk/greencompany/co2calculator.htm>

Powertek. (2008). *Model ISW8000 Single Phase 4 digit Wattmeter*. Retrieved March,

2008, from <http://www.powertekuk.com/isw8000.pdf>

- RESOL Controllers for Thermal Systems. (n.d.). RESOL Information. Retrieved April 7, 2008, from <http://www.windpowerenergy.co.uk/heat-pumps.htm>
- Schneider, S. H., Semenov, S., Patwardhan, A., Burton, I., Magadza, C., Oppenheimer, M., et al. (2007). *Climate Change 2007: Impacts, Adaptation*. Retrieved from <http://www.ipcc.ch/pdf/assessment-report/ar4/wg2/ar4-wg2-chapter19.pdf>
- Stern, N. (2006, October 3). *Stern Review: The Economics of Climate Change*. Retrieved April 3, 2008, from [http://www.hmtreasury.gov.uk/independent\\_reviews/stern\\_review\\_economics\\_climate\\_change/stern\\_review\\_report.cfm](http://www.hmtreasury.gov.uk/independent_reviews/stern_review_economics_climate_change/stern_review_report.cfm)
- Telkes, M. (n.d.). Space Heating with Solar Energy. *The Scientific Monthly*, 69(6), 394-397. Retrieved February 13, 2008, from JSTOR database:  
<http://links.jstor.org/sici?sici=00963771%28194912%2969%3A6%3C394%3ASHWSE%3E2.0.CO%3B2-G>
- Trenberth, K. E., & Jones, P. D. (2007). IPCC Fourth Assessment Report. Unpublished raw data. Retrieved February 13, 2008, from Intergovernmental Panel on Climate Change Web site: <http://www.ipcc.ch/pdf/assessment-report/ar4/wg1/ar4-wg1-chapter3.pdf>
- United Nations Environment Programme. (2007, September). *Climate Change Fact Sheet* [Pamphlet]. Author. Retrieved February 17, 2008, from UN Department of Public Information Web site:  
[http://www.unep.org/Themes/climatechange/PDF/factsheets\\_English.pdf](http://www.unep.org/Themes/climatechange/PDF/factsheets_English.pdf)

US DOE. (2006). *Geothermal Technologies Program*. Retrieved February 3, 2008, from

U.S. Department of Energy Web site:

<http://www1.eere.energy.gov/geothermal/powerplants.html>

US DOE. (2006). *Photovoltaics*. Retrieved February 16, 2008, from U.S. Department of

Energy Web site: <http://www1.eere.energy.gov/solar/photovoltaics.html>

US DOE. (2006). *Solar Water Heaters*. Retrieved February 16, 2008, from U.S.

Department of Energy Web site:

[http://www.eere.energy.gov/consumer/your\\_home/water\\_heating/index.cfm/mytopic=12850](http://www.eere.energy.gov/consumer/your_home/water_heating/index.cfm/mytopic=12850)

US DOE. (2006). *Wind Energy*. Retrieved February 3, 2008, from U.S. Department of

Energy Web site:

[http://www1.eere.energy.gov/windandhydro/wind\\_technologies.html](http://www1.eere.energy.gov/windandhydro/wind_technologies.html)

US DOE. *Biomass Basics*. (2006). Retrieved February 12, 2008, from U.S. Department of

Energy Web site: [http://www1.eere.energy.gov/biomass/biomass\\_basics.html](http://www1.eere.energy.gov/biomass/biomass_basics.html).

Wilmersdorf, E. (November 2003). Geocoded information incorporated into urban

online services-the approach of the City of Vienna. *Computers, Environment and*

*Urban Systems*, 27(6), 609-621

Wilson, A. (Ed.). (2001). Combined Heat and Power. In *Greening Federal Facilities: An*

*Energy, Environmental, and Economic Resource Guide* (2nd ed., pp. 130-131).

Retrieved February 3, 2008, from BuildingGreen, Inc. Web site:

<http://www1.eere.energy.gov/femp/pdfs/29267-5.8.8.pdf>