



**WPI**

# The Design of an Adjustable Ankle Brace

---

A Major Qualifying Project Report

Submitted to the Faculty

of the

WORCESTER POLYTECHNIC INSTITUTE

in partial fulfillment of the requirements for the  
Degree of Bachelor of Science

by

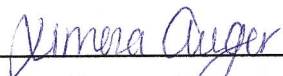
  
Ximena Auger

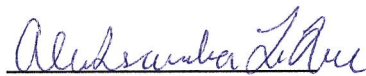
  
Aleksandra LaRue

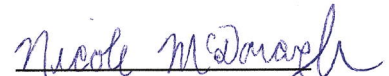
  
Nicole McDonough

  
Isabel Pagliaccio

  
Asher Plange

October 15, 2013

Project Advisor

Professor Brian James Savilonis, Ph.D

## Table of Contents

Table of Figures .....	5
Abstract .....	7
1. Introduction.....	8
2. Background.....	10
2.1. Ankle Anatomy .....	10
2.1.1. Ankle Joint.....	10
2.1.2. Ligaments.....	11
2.1.3. Muscle and Tendons .....	14
2.2. Ankle Sprain Grades.....	14
2.3. Types of Ankle Sprains.....	15
2.4. Sports History .....	15
2.5. Precautionary Measures.....	16
2.6. Issues with Braces.....	17
2.7. Current Products and Patents .....	19
2.7.1. Current Products.....	19
2.7.2. Patents .....	20
2.8. Ankle Strength .....	23
2.9. Testing.....	24
2.10. Ankle and Brace Analysis .....	27
2.10.1. Ligament Analysis .....	27
2.10.2. Brace Analysis .....	34
3. Project Strategy .....	39
3.1. Initial Client Statement.....	39
3.2. Objectives .....	39
3.3. Constraints.....	40
3.4. Revised Client Statement .....	41
3.5. Project Approach .....	42
3.5.1. Technical Approach.....	42
3.5.2. Management Approach .....	45
3.5.3. Financial Approach .....	45
4. Alternative Designs .....	47
4.1. Needs Analysis .....	47
4.2. Functions and Specifications .....	47
4.3. Conceptual Designs .....	48
4.3.1. Inserts .....	49
4.3.2. Straps .....	49
4.3.3. Compression .....	50

4.3.4. Functions Means Chart .....	51
4.4. Preliminary/Alternative Designs.....	51
4.4.1. Preliminary Design Idea #1: Shoe Brace Design .....	51
4.4.2. Preliminary Design Idea #2: Alternative Brace .....	52
4.4.3. Preliminary Design Idea #3: Moldable Plastic Ankle Support .....	53
4.4.4. Preliminary Design Idea #4: Two Part Ankle Brace.....	54
4.4.5. Preliminary Design Idea #5: Adjustable Ankle Brace.....	54
4.5. Decisions and Optimization .....	55
5. Design Verification .....	56
5.1. Preliminary Testing .....	56
5.2. Force Plate Testing .....	57
5.3. Detachable Sole Testing – Reaction Time .....	61
5.4. Detachable Sole Testing – Linear Potentiometer.....	65
6. Discussion .....	68
6.1. Preliminary Testing .....	68
6.2. Force Plate Testing .....	70
6.3. Detachable Sole Testing – Reaction Time .....	71
6.4. Detachable Sole Testing – Linear Potentiometer.....	73
6.5. Tilt Testing .....	73
6.6. Statistical Analysis.....	74
6.7. Project Considerations and Impacts.....	75
6.7.1. Manufacturability .....	75
6.7.2. Economics .....	75
6.7.3. Ethics.....	75
6.7.4. Social .....	75
7. Final Design and Validation .....	77
7.1. The Final Design: The Adjustable Ankle Brace .....	77
7.2. Testing Methods.....	79
8. Conclusions and Recommendations .....	83
8.1. Conclusions .....	83
8.2. Recommendations.....	83
8.2.1. Testing Recommendations .....	83
8.2.2. Design Recommendations .....	84
References.....	86
Appendices.....	90
Appendix A: Table of the Most Commonly Injured Body Sites in Sports .....	90
Appendix B: Project Team’s Objective Tree .....	91
Appendix C: Project Team’s Pairwise Comparison Chart .....	91

Appendix D: FBD of Single Leg Stance .....	92
Appendix E: Equations for FBD of Single Leg Stance .....	93
Appendix F: Email to Undergraduate Students .....	94
Appendix G: Informed Consent Form.....	95
Appendix H: Questionnaire .....	99
Appendix I: Preliminary Testing Error Score Sheet .....	100
Appendix J: Detachable Sole Apparatus and Force Diagram .....	101
Appendix K: Gantt Chart .....	102
Appendix L: Linear Responsibility Chart .....	103
Appendix M: Average Elapsed Time for All Test Subjects .....	104

## Table of Figures

Figure 1: Ankle Joints.....	11
Figure 2: Lateral Ligaments of the Ankle.....	12
Figure 3: Medial Ligaments of the Ankle .....	13
Figure 4: Inversion, Eversion, and Syndesmosis of the Ankle .....	15
Figure 5: US Patent 5,868,693.....	21
Figure 6: US Patent 6,056,713.....	21
Figure 7: US Patent 4,495,942.....	22
Figure 8: US Patent 5,472,414.....	23
Figure 9: Passive Stability Testing.....	25
Figure 10: Trap Door Apparatus .....	25
Figure 11: Force Diagram for Detachable Sole Apparatus .....	26
Figure 12: Detachable Sole Apparatus.....	27
Figure 13: Stress-Strain Curve for Ligaments.....	27
Figure 14: Lateral View of the Ankle .....	28
Figure 15: FBD of ATFL and CFL Modeled as Springs.....	28
Figure 16: Posterior View of the Ankle when Standing on a Flat Surface.....	29
Figure 17: Posterior View of the Ankle at 20 Degree Inversion.....	30
Figure 18: Anterior View of the Ankle .....	31
Figure 19: Posterior View of the Ankle with Ankle Support .....	35
Figure 20: Dimensions of Final Brace showing from left to right: Side View, Front View, and Bottom View.....	49
Figure 21: Insert Model of Ankle Brace.....	49
Figure 22: Strap Brace Method .....	50
Figure 23: Compression Sock Brace .....	50
Figure 24: Sketch of Shoe Brace Design .....	52
Figure 25: Sketch of Alternative Brace Design.....	53
Figure 26: Sketch of Moldable Plastic Ankle Support.....	54
Figure 27: Preliminary Testing Data showing Error Score Averages for each Trial .....	57
Figure 28: AMTI-Net Force Program Screenshot.....	58
Figure 29: BIOANALYSIS Program Screenshot.....	59
Figure 30: Example of COP Graph for Trial 1.....	59
Figure 31: Example of a plot of average deviations from the mean for COP X for one subject for trials 1-5.....	60
Figure 32: Average Deviations from the Mean for Different Data Types .....	61
Figure 33: Detachable Sole Apparatus.....	62
Figure 34: Example of graph created with data acquired from the Detachable Sole Test.....	63
Figure 35: Detachable Sole: Time elapsed from initial touch to inversion.....	63
Figure 36: Example of Value Selection for Elapsed Time Calculation .....	64
Figure 37: Average of all subjects elapsed time for each trial. ....	64
Figure 38: Linear Potentiometer.....	65
Figure 39: Linear Potentiometer attached to the calf of a test subject. ....	65
Figure 40: Arduino Uno used to record data from the linear potentiometer.....	66

Figure 41: Screenshot of Arduino software used to record the angle of the potentiometer. ....	66
Figure 42: Data found from the linear potentiometer and detachable sole test. ....	67
Figure 43: Preliminary testing data showing error score averages for each trial. ....	69
Figure 44: Force in Z-axis Analysis of average deviation from the mean. ....	70
Figure 45: Average deviations from the mean for different data types. ....	71
Figure 46: Example of Time Values per Trial. ....	72
Figure 47: Average of All Subject Elapsed Time of Each Trial. ....	72
Figure 48: Data found from the linear potentiometer and detachable sole test. ....	73
Figure 49: Final Design of Ankle Brace. ....	77
Figure 51: Straps on the Detachable Sole. ....	80
Figure 52: Dimensions for the Tilt Test. ....	81

## **Abstract**

The objective of this project is to reduce the incidence of ankle inversion and eversion injuries by designing, prototyping, and testing a new brace that would provide three stages of ankle support and rehabilitation. There are many ankle braces in the market today; however, they are all targeted toward a specific stage during rehabilitation. Buying a new brace for each step of recovery has proven to be costly. Analysis, material selection, and computer aided design drawings were conducted as well as the development of a prototype brace and testing apparatus. Using a force plate and potentiometer to record data, human test subjects were used to test the new design against an unbraced ankle as well as a brace commonly found in the market. Statistical analysis was performed and the average error score as well as the recorded reaction time supports our conclusion that the designed brace increases stability.

## 1. Introduction

Ankle sprains are among the most frequent injuries seen in emergency departments nationwide. With an estimated incidence rate of 2.15 sprains per 1000 people each year approximately 85 percent of all ankle injuries treated by physicians are ankle sprains.(Barry, 2013)(Denyer, 2013). This is due to the large cyclic loading the ankle receives during activity. Compared to the other lower limb joints the ankle receives the most pounds of pressure during loading. During sports and physical activity, the ankle joint bears relentless strain and high pressure loads. Sprains occur during these activities due to instantaneous forces that cause the joint to move in a direction beyond its physical limits.

Due to the frequency of ankle injuries ankle braces have been developed to provide stability to the ankle. These braces are used to prevent ankle injury or to provide extra support for the ankle during its healing after an injury occurs. Although ankle braces provide a stabilizing benefit, dependency on braces weakens the ankle over time. Ankle braces can also cause the forces being applied to the ankle to be extended to the knee which, with significant use, could cause knee problems. Due to the wide range of ankle stability varying from person to person different types of braces have been created to suit different needs. In order to allow for different levels of stability, ankle braces on the market today vary in their level of support with three common stages including: light, medium and maximum.

The ankle is made up of three different joints; the talocrural joint, the subtalar joint, and the inferior tibiofibular joint. These joints are held together by four major ligaments; the deltoid ligament, the anterior talofibular ligament, the posterior talofibular ligament, and the calcaneofibular ligament, which can be damaged during an ankle sprain. There are three major types of ankle sprains; inversion, eversion, or syndesmosis, which is also known as a high ankle sprain. The most common ankle injury is inversion, which accounts for approximately 90% of all ankle sprains (Wolfe, Uhl, Mattacola & McCluskey, 2001). Inversion is caused by a rapid change of speed or direction, which in turn causes the ankle joint to roll outward as the leg moves inward. Due to its placement, the anterior talofibular ligament receives a majority of the stress during inversion; therefore, it is the most commonly injured ligament. Without appropriate intervention and proper care, injury to the ankle ligaments can result in chronic pain or possible re-injury. The type of care needed is determined by the severity of the sprain. This severity is graded on a scale of I to III, with a grade III sprain being the most severe, involving a complete rupture of one or more of the ankle ligaments. Although the treatment varies depending on the grade all ankle sprains can be damaging if not treated properly.



The purpose of this project is to develop an ankle support for athletes that will help prevent re-injury of the ankle during the healing process. The team plans to design an adjustable ankle brace that can be used throughout all the healing stages of the ankle. The adjustability of the brace will allow the user to reduce the support it provides as the injury heals so that the user's ankle does not become dependent on the brace. The design will focus on the prevention of ankle inversion and eversion while also being comfortable, affordable, and easy to use.

In order to design an ankle brace, the forces applied to the ligaments during ankle sprains were thoroughly analyzed. Extensive background research on the failure properties of ligaments was conducted and basic free body diagrams (FBD's) of the ankle and foot were drawn in order to fully understand the forces affecting the stability of the ankle. With Institutional Review Board (IRB) approval, preliminary testing for ankle stability was conducted on a group of eight male and nine female WPI students. The project team designed and built testing apparatuses based on previous research and testing that has been conducted. Rapidly induced stability testing to test the hind foot inversion angle was done without an ankle brace and with ankle braces on the same sample of WPI students to test the change in ankle stiffness. Based on the data gathered, conceptual designs were produced using an informed engineering approach. The team's final design was then selected by analyzing the conceptual designs using a function means chart. Once again, a rapidly induced stability test was done to compare the results of the final design to current products in order to ensure correct stability for each stage of healing. The project team also created guidelines and recommendations for the stages of ankle healing and the length of time the ankle support should be worn.

The background section outlines the anatomy of the ankle as well as the different ankle sprain types and grades, some history of ankle sprains in sports, the difference between preventative and injury wear, products on the market looking specifically at patents and what is currently considered the best ankle brace as well as problems with current products, and a brief description of tests done on the ankle and braces. The project strategy discusses the team's objectives and constraints for their design. The objectives and constraints helped focus on specific aspects of the design and led to the formation of a final client statement. The general approach of how the project will be done is then discussed. Alternative designs are then developed and ranked. Using a function means chart the team's final design is chosen. The design's impact on society, the environment, and the economy are discussed as a whole. Finally, the conclusions drawn from the project and future recommendations are discussed in detail.

## 2. Background

### 2.1. Ankle Anatomy

The ankle is a complex anatomical structure consisting of many important components including bones, ligaments, tendons, muscles, and nerves. The ankle joint is a uniaxial, modified hinged joint that participates in the movement and stability of the foot. The components of this joint allow the ankle to move in a wide range of motions consisting of plantar flexion, dorsiflexion, inversion, and eversion. In the following sections joints, ligaments, muscles and tendons that aid in movement and stability of the ankle will be discussed.

#### 2.1.1. Ankle Joint

The ankle joint is formed by three bones: the tibia, the fibula and the talus. These bones are coated in articular cartilage allowing the bones to move smoothly against each other during ankle motion. The tibio-talar joint lies between the top of the talus, the medial malleolus of the tibia, and the lateral malleolus of the fibula (Figure 1). The active range of motion for this joint is approximately 15 to 20 degrees vertically upward, called dorsiflexion, and 45 to 55 degrees vertically downward, called plantar flexion. During normal running, however, maximal dorsiflexion is approximately 10 degrees while the maximal plantar flexion is approximately 14 degrees. An ankle with full weight-bearing can achieve a maximum dorsiflexion of approximately 40 degrees (Norkus & Floyd, 2001).

The subtalar joint is a gliding joint that lies below the talus and above the calcaneus or heel bone (Figure 1). The motion of this joint consists of approximately 25 to 30 degrees inward called inversion and 5 to 10 degrees outward called eversion. (Dubin JC, Comeau, McClelland, Dubin RA, & Ferrel, 2011). This joint is held together by an articular capsule and by the anterior, posterior, lateral, medial and interosseous talocalcaneal ligaments.

The distal or inferior tibiofibular joint is a fibrous joint composed of the syndesmotric articulation between the convex surface of the distal fibula and the concave surface of the distal tibia. The distal anterior tibiofibular ligament, distal posterior tibiofibular ligament, transverse ligament and interosseous ligament work to stabilize this joint. The most distal section of the interosseous ligament helps stabilize the joint (Norkus & Floyd, 2001).

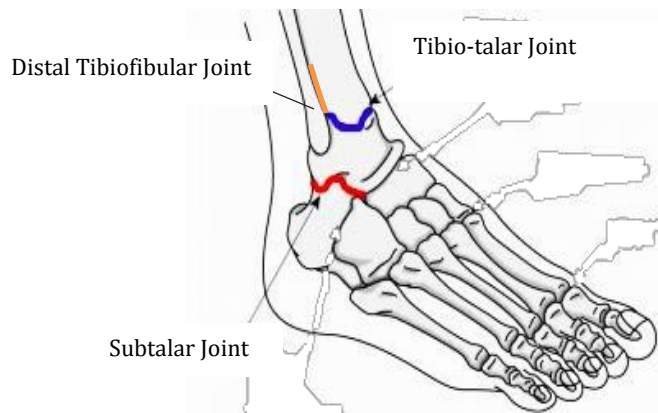

Figure 1: Ankle Joints

### 2.1.2. Ligaments

Ligaments are soft fibrous tissues that connect bones to other bones. They are mainly composed of dense parallel bundles of collagen fibers. These collagen fibers are arranged in a smooth wave like pattern called a crimp. (Dubin JC, Comeau, McClelland, Dubin RA, & Ferrel, 2011) A study conducted in 2011 Dubin explains that,

“The crimp of the ligament has been equated to the action of a spring. When the ligament is placed under tension, the crimp of the ligament straightens; and collagen fibers are recruited to dissipate internal forces and resist excessive motion. If these forces do not exceed the mechanical strength of the ligament, pathological motion of the ankle is prevented; and the crimp of the ligament recoils. However, if the load surpasses the mechanical strength of the ligament and is applied at a fast velocity that exceeds the speed of a corrective muscle reflex, it may lead to microscopic failure of the collagen fibers or a complete rupture of the ligament.”

The ankle ligaments surround the bones and provide support to the tibio-talar, subtalar and distal tibiofibular joints while also preventing abnormal twisting, turning and rolling of the foot.

#### 2.1.2.1. Lateral Ligaments

Lateral ligaments are located on the lateral or outer side of the ankle and are the most common ligaments to be torn or injured in lateral ankle sprains including inversion and eversion. The three lateral ligaments are the anterior talofibular ligament, the calcaneofibular ligament and the posterior talofibular ligament. These lateral ligaments aid in the prevention of excessive eversion of the subtalar ankle joint.

The anterior talofibular (ATF) ligament is the weakest and most frequently injured ligament in the ankle. It connects the talus bone to the lateral malleolus of the fibula (Figure 2). The dimensions of the ATF ligament are on average 7.2 mm wide and 24.8 mm long. At a neutral position the ATF ligament lays horizontal. During dorsiflexion it moves upward while the upper band is relaxed and the lower band is tensed. During plantar flexion it moves downward while the upper band is tensed and the lower band is relaxed (Golano et al., 2010). As the foot moves from dorsiflexion to plantar flexion the strain in the ligament increases. While in plantar flexion, the ligament works to prevent inversion of the ankle, in addition to, limiting anterior displacement and medial shifting of the talus and posterior displacement and lateral rotation of the tibia and fibula. Additionally, the ATF ligament compared to other ankle ligaments demonstrates a low load and energy to failure when undergoing tensile stress. This property may be a factor in the frequent tearing and stretching of the ATF ligament (Hertal J, 2002).

The calcaneofibular (CF) ligament is the second most often injured lateral ligament. This ligament is positioned directly below the ATF ligament and is the only ligament that joins the subtalar joint and tibio-talar joint. The primary function of the CF ligament is to prevent lateral talar tilt while providing stability to the subtalar joint. This ligament on average is approximately 20 mm long with a width of about 6-8 mm. The majority of CF ligament is covered by peroneal tendons and a sheath, which leaves around 1 mm of the ligament uncovered.

The posterior talofibular (PTF) ligament is the least common of the lateral ligaments to be injured in ankle sprains. It originates at the medial surface of the lateral malleolus and extends horizontally and entwines to the posterior surface of the talus. In neutral ankle position and plantar flexion the ligament is relaxed whereas in dorsiflexion the ligament is tensed.

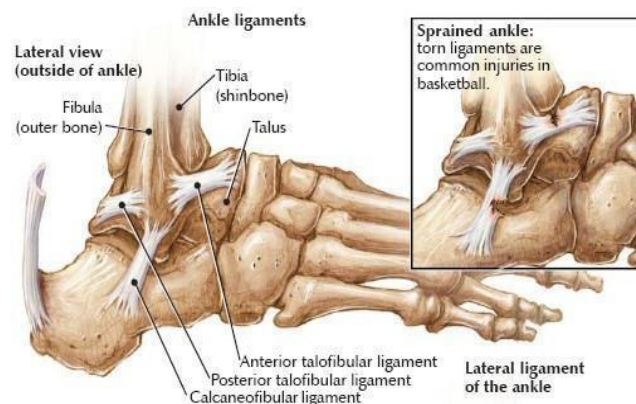

### 2.1.2.2. Medial Ligaments

The medial deltoid ligaments are the strongest ankle ligaments especially during plantar flexion. The anterior talofibular ligament, posterior talofibular ligament, tibiocalcaneal ligament, and tibionavicular ligament are the four deltoid ligaments which form a triangular shape around the ankle joint (Figure 3). The primary function of these ligaments is to prevent excessive eversion of the ankle, specifically in the subtalar joint. The medial ligaments support the medial or inner side of the ankle and connect the medial malleolus to the tarsal bones. These ligaments are composed of two layers, the superficial layer and the deep layer. The superficial layer crosses the tibio-talar and the subtalar joint. The superficial layer consists of the tibionavicular, tibiocalcaneal, and tibio-talar ligaments. . The strongest superficial layer ligament is the tibiocalcaneal ligament, which prevents calcaneal eversion. The deep layer, which is also the strongest component of the medial ligaments, crosses only the tibio-talar joint and functions as a primary stabilizer at the medial ligaments. Additionally, it prevents lateral shifts of the talus and limits dorsiflexion of the foot. The two medial deep layer ligaments are the anterior and the posterior tibio-talar ligament. These deep layer ligaments prevent excessive lateral displacement and external rotation of the talus. (Dubin JC, Comeau, McClelland, Dubin RA, & Ferrel, 2011).

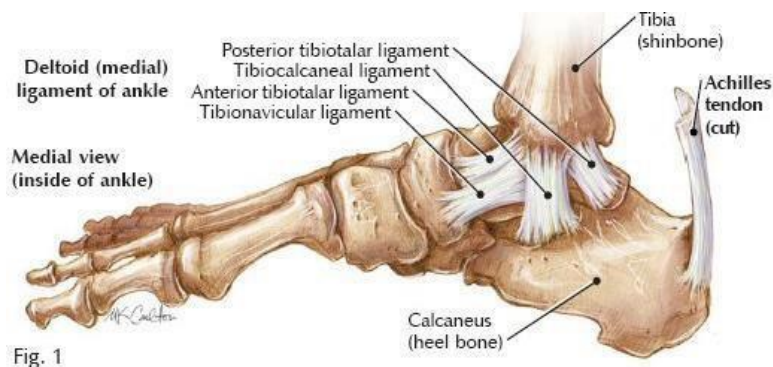

Figure 3: Medial Ligaments of the Ankle ([morphopedics.wikidot.com](http://morphopedics.wikidot.com))

### 2.1.2.3. Syndesmosis Ligaments

The syndesmotic articulation of the tibia and fibula is subdivided into three regions; the anterior inferior tibiofibular ligament, the interosseous ligament, and the posterior fibular ligament. The anterior inferior tibiofibular ligament originates at the anterior tubercle of the tibia and extends distally to the lateral malleolus. This ligament independently prevents the excessive fibular movement and external talar rotation. The interosseous ligament lies beneath the anterior inferior tibiofibular ligament and originates from the anterior inferior triangular aspect of the lateral malleolus and runs to the lateral surface of the tibia, functioning primary to hold the tibia and fibula

together. The interosseous ligament also acts as a spring and allows minimal separation between the medial and lateral malleolus at the tibular joint during dorsiflexion. (Norkus & Floyd, 2001). The posterior inferior tibiofibular ligament originates at the posterior tubercle of the tibia and extends distally and laterally to the posterior lateral malleolus. This ligament has both superficial and deep components. The posterior inferior tibiofibular ligament works closely with the anterior inferior tibiofibular ligament to maintain a good contact of the tibia and fibula.

### **2.1.3. Muscle and Tendons**

Muscles and tendons are vital components in maintaining ankle joint function. Some important tendons that affect the ankle complex include: the Achilles tendon, the tibial tendons, and the parandou tendons. A tendon is fibrous collagen that attaches bone to muscle. The Achilles or calcaneal tendon attaches the two calf muscles, the soleus and the gastrocnemius muscles, to the calcaneus. This tendon allows both plantar flexion and dorsiflexion and is important in walking and running. The tibial tendon has two different regions, anterior and posterior. The anterior tibial tendon allows dorsiflexion of the foot. The posterior tibial tendon runs behind the medial malleolus and allows inversion of the foot. The main function of the posterior tibial tendon is to maintain the arch of the foot. The paraneus tendons are composed of the paraneus longus tendon and the parandou brevis tendon. The paraneus longus tendon is the longer tendon of the two. It extends from the bottom of the foot to the peroneal muscle. The parandou brevis tendon is the shorter of the two and only extends from the fifth metatarsal to the peroneal muscle.

## **2.2. Ankle Sprain Grades**

There are three types of ankle sprains: grade I, grade II and grade III. The lowest level of sprains is a grade I sprain. A grade I, is mild and causes minor stretching of the ligaments and microscopic tearing of the collagen fibers. For this grade of sprain most patients have minimal swelling and soreness and normally do not need crutches. The second level of sprain is a grade II which is a moderate ankle sprain that causes partial tearing of the ligaments. For this grade of sprain patients have moderate swelling and bruising, decreased range of motion, and some instability. Treatments often include brace immobilization and physical therapy. Finally, a grade III is a severe ankle sprain caused by a complete tear of the ligament. Most patients cannot walk on the ankle and have significant swelling and instability. Treatments often require maximum immobilization including a brace and possibly crutches. Some cases require long-term physical therapy in order to correctly heal the joint (American Academy of Orthopedic Surgeons, 2012).

### 2.3. Types of Ankle Sprains

There are three types of sprains that the ankle can undergo: inversion or lateral ankle sprains, eversion ankle sprains, and high or syndesmotic ankle sprains. The most common type of ankle sprain is an inversion ankle sprain, which accounts for approximately 90% of all ankle sprains. An inversion sprain is where the foot is inverted or twisted inwards. When the foot exceeds the maximum range of eversion, it results in stress on the lateral side of the ankle and stretching and tearing in the lateral ligaments (Figure 4).

The second type of ankle sprain is an eversion ankle sprain. In an eversion ankle sprain the foot twists outward. When the foot exceeds its maximum range of inversion, it results in excessive stress on the medial side of the ankle and stretching and tearing of the deltoid ligaments (Wolfe, Uhl, Mattacola & Mccluskey, 2001).

The final type of ankle sprain is a high or syndesmotic ankle sprain. This type of sprain occurs by the abnormal twisting of the ankle, damaging the syndesmosis ligaments or the ligaments between the tibia and the fibula. Approximately 1-10% of all ankle injuries are high ankle sprains. High ankles sprains are the least common type of ankle sprain and have a much longer recovery time in both inversion and eversion ankle sprains (Norkus & Floyd, 2001).



Figure 4: Inversion, Eversion, and Syndesmosis of the Ankle ([www.webmd.com](http://www.webmd.com))

### 2.4. Sports History

There are over 420,000 collegiate athletes in the US alone. Therefore, one can only imagine the number of players who endure an injury throughout the course of an NCAA season (NCAA, 2012). Although there are two very different types of sports, contact and non-contact, injuries are one aspect they have in common. Basketball is a classic example of a sport with high potential for

injury. The large amount of jumping, sharp angled cuts, and stress being applied to lower joints throughout the course of a single game creates a number of opportunities for potential injury. The most common injury among basketball players is the acute ankle sprain, which is also the most common type of injury in contact sports as a whole (Yung et. al, 2007). However, this injury also applies to numerous non-contact sports such as volleyball or figure skating. The acute ankle sprain is not only one of the most common, but it is also considered to be the joint region requiring the most precautionary measures.

The potential for injury, in any sport, is one of the most frequently analyzed aspects of the sports science world. After numerous case studies have been conducted on athletes and various sports, ankle injuries have been proven to be the most prevalent injuries. Ankle injuries have plagued athletes of all sexes, ages, and sizes. Lucile Packard Children's Hospital at Stanford reported that in the US, over 3.5 million children ages 14 and under are injured annually playing sports (Lucile Packard Children's Hospital, 2012). With such a large number of injuries, the need for precautionary measures to protect the ankle becomes vital to all athletes. Drawbacks of ankle injuries range from minor discomfort to immobilization of the entire foot region to potential surgery.

Data was collected from 70 different sports in 38 different countries and uncovered a total of 201,600 injuries with 32,509 of those injuries being related to ankles (Appendix A). A summary of the results showed that the most common injury in 24 sports, was the ankle (34.3%), followed by the knee in 14 sports (20.0%), head in 8 sports (11.4%), trunk in 6 sports (8.6%) and the hand in 6 sports (8.6%). Appendix A also shows the weighted percentage of ankle injury in the 70 sports that were included in the study. Ankle injury was most common in aero ball (80.0%), wall climbing (60.0%), indoor volleyball (45.6%), mountaineering (40.0%), netball (39.8%), and field events in track and field (39.2%) (Yung et. al, 2007). From this information we can conclude that not only are ankles the most likely region of the body to be injured, but no matter the sport, contact or non-contact, all athletes are at risk.

## **2.5. Precautionary Measures**

According to Tom McGuine from the American Journal of Medicine, ankle sprains have become an epidemic in the last 50 years. Statistically speaking ankle injuries have been identified as 15% of all sports injuries and could be considered the single most common injury in sports today. In basketball, inversion ankle sprains are the most frequent sprain type accounting for 36% of all injuries to boys and girls. Ankle sprains also account for 14% of all high school football



injuries. In the United States alone 74,014 ankle injuries occur every year during high school football.

To counteract the large amount of injuries, sports science as well as the number and types of ankle braces continue to evolve. Currently there is an abundance of options for athletes to choose from, ranging from braces meant for preventative measures to those aimed towards acute ankle injuries. Due to varying theories on which form of support is the most effective means of protecting the ankle, ankle braces and ankle tape options are often difficult to choose between. It has been noted that most recreational athletes tend to believe that the rigidity, strength, and adjustability of ankle braces make them more effective than ankle taping from an athletic trainer since taping loses support over time. However, material ankle braces encounter similar problems due to the length of time athletes wear them and their constant use. The strength and durability of solid athletic tape is also often underestimated. Ankle taping provides stability while allowing necessary motion, and is a very good preventative measure against acute lateral ankle sprains. (Fiolkowski, 1998)

The action taken towards ankle injury prevention or re-aggravation depends on the degree of severity of the injured region, but a general comparison of ankle braces and taping will give the pros and cons of both options. During the acute phase of ankle sprain management, bracing is more ideal not only because of the adjustability of the straps and laces but also because of the simplicity of its application and removal. On the other hand, taping has many benefits. Research has shown that “taping may provide superior benefits with regard to deceleration of inversion velocity and facilitation of dynamic neuromuscular protective mechanisms” (Halseth, 2004). Additionally, taping addresses the intricate interrelated biomechanical factors that are responsible for both the subtalar joint injury and rotary instability of the talocrural joint (Wilkerson, 2002). Although ankle braces have been found to be not as effective as recently applied tape, it is more realistic to tighten or re-adjust a brace than to re-tape an ankle during continuous activity (Pre-Wrap, 2013). Ultimately, the decision is left to the athlete depending on the desired restriction of motion as well as comfort and compatibility within their footwear.

## **2.6. Issues with Braces**

Ankle braces are used for increased support, healing, and also as a preventative measure to lower an athlete’s chance of an ankle sprain. Although braces have been shown to have strong supportive benefits, brace overuse is becoming a rising concern among coaches and physical therapists (Gardner, 2012). The reason for this concern is that individuals become increasingly reliant on the brace’s support instead of relying on their natural ankle strength. This dependence slowly decreases the individual’s ankle strength over time. A way to reduce this effect is by bracing

the ankle during contests but partaking in physical conditioning and therapy without them. This allows the athlete to build up strength in their ankle while still protecting it during the more active part of their sport. Athletes tend to use braces past their viable lifetime. If the brace is overused the materials stretch and distort so they are not as effective as they were when the brace was new.

Another problem, considered by athletes more so than doctors, is that braces tend to restrict the range of ankle motion. Since the ankle joint is meant to be extremely mobile, athletes are concerned that with restricted ankle motion their athletic capability will diminish (Malin, 2013). However, braces are made to restrict the ankle's motion but if motion is too heavily restricted then the brace could negatively affect the ankle during game situations. Results of a study from Ubell suggested that ankle braces effectively reduced ankle inversion ROM-range of motion- thus decreasing the risk of ankle injury. The study also supported the statement that ankle braces limit the frequency of ankle sprains (McGuine, 2012).

An ankle has the ability to invert up to 30 degrees before damage occurs. Therefore, braces are made to keep the ankle within 25 degrees of inversion to prevent injury, while still allowing for a comfortable range of motion. Although many believe that the more restriction there is on the ankle the safer the joint is, the opposite may also be true in that the ankle should have as little restriction as possible to function properly and be "safe". Some theories state that too much ankle restriction can increase the risk of injury (Gardner, 2013). Too much restriction can lead to soft tissue atrophy in the ankle joint and decrease the ankle's ability to restrict excessive ranges of motion when it is not braced. Additionally, reduction in dorsiflexion can negatively affect other joints in the body. The brace causes the ankle to absorb less energy, which in turn causes this energy to be displaced to other leg joints. The extra forces applied due to this displacement puts joints like the knee and hip at a greater risk of injury. Kareem Abdul-Jabaar recognized this issue and publicly commented on it saying, "Your skeletal system was built to absorb shock. If you bind your ankles, the stress is going to get transferred to the next available joint - your knee" (Malin, 2013). In 1992, a study was performed to research the distribution of forces with and without braces. In the study it was found that the energy absorption of jump landings without a brace to be distributed as 37%, 37%, and 25% through the ankle, knee, and hip whereas the measurements for landings with a brace were 31%, 50%, and 20%. This increase in the energy absorption increased the potential for ligament injury in the knee joint. Another study conducted on how braces are used in basketball found a trend of lower extremity injuries in players that wore ankle braces (McGuine, 2013). These studies show that although ankle braces

do reduce the forces acting on the ankle, those forces are not removed from the body but are instead just acting on a different area.

## 2.7. Current Products and Patents

### 2.7.1. Current Products

Currently in the market there are four main styles of ankle braces. These styles include stirrup, sleeve, lace up, and wrap around ankle braces. Some companies may combine two or more of these styles to try and improve their brace, such as using a lace up bodice combined with additional Velcro straps to wrap around the ankle to provide further support (Way and Path, 2011).

When choosing the style of brace and the materials used to create a brace, companies have ideas and statistics that influence their decision making process; some braces are even made for specific sports. This is because the playing surface, athletic shoe, and types of loads being applied differ between sports. These factors have a huge impact on the design of a brace and its effectiveness. An athlete who plays soccer on a turf field has different needs than one who plays volleyball on a gymnasium floor (Wagner, 2009). During the design of an ankle brace, one of the last aspects looked at is sizing; however, sizing is a contributing factor when it comes to the effectiveness of the brace. An athlete with significantly smaller ankles than the “norm” has a higher chance of rolling their ankle due to the lack of muscles and support provided around their joint. It has also been found that overweight athletes, because of the increased forces due to their weight, are also more likely to injure their ankles during physical activity (Fiolkowski, 1998). The best brace style on the market, as of 2013, is a brace with a lace up bodice that has Velcro straps for additional lateral restrictions (Gardner, 2012). It is modeled similarly to the ideal ankle brace which is one that externally supports the ankle ligaments at only the end ranges of motion just before ligament failure.

The ASO ankle brace would be considered the “gold standard of ankle braces” in the market as of 2013. The qualities that make this brace stand out include (Goodrich, 2013):

- Good feel
- Figure 8 strap system that helps lock heel in place to help prevent ankle sprains (Way and Path, 2011)
- Two piece upper ankle strap
- More limited range than some other braces (Swede-O strap Lok) but the support and quality are better
- 6 lace up rivets

- Easy on/off
- Can be used for multiple years (Goodrich, 2013)
- Lightweight
- No plastic inserts make it comfortable for all day use
- Good use for preventative measures or after acute ankle sprains to provide support during rehabilitation

ASO also makes an ankle brace with plastic strays, inserts that run down the side of the brace, which is better suited for athletes who have suffered numerous ankle sprains and need a more stable ankle brace. The strays are added for additional medial and lateral support. One of the weaker aspects of the design is that the base of the brace is bulkier and will be slightly harder to fit inside certain types of shoes. The plastic strays are also believed to decrease the brace's overall comfort (Elis, 2002). Another company, McDavid, uses steel spring stays in their 1999 Lightweight Ankle Brace design. These stays are less rigid than the plastic ones making for a more comfortable fit and a less bulky design.

Although there are many braces on the market today, taping is still a popular option. The perks to adhesive taping include: lightweight capability, rare custom fit to the ankle that has yet to be achieved by bracing, ability to support a certain area, and the ability to be proportional to the severity of the injury. Unfortunately, adhesive taping loses as much as 40% of its supportive ability as early as 20 minutes into active use. Another disadvantage is that taping is much more expensive than the alternative, a brace. For example a basketball team of 12 people would use approximately \$4,800 in tape while bracing for the same team would only cost around \$960 (Fiolkowski, 1998).

### 2.7.2. Patents

Many patents were given to designs of ankle braces that prevent inversion and eversion of the ankle; however, none of them were made to be adjustable to the stages of ankle healing. Therefore, dependency is still an issue which could lead to knee problems and brace overuse. Several different patents are described below.

Duback, Floyd, and Friday designed a custom-fitted athletic ankle brace by using a hardenable brace panel that can be molded to the medial and lateral aspects of the lower leg and ankle of the wearer. Once the brace panel is hardened it provides a rigid custom fit support for restricting inversion and eversion of the foot during wear. The brace also has a hardenable posterior heel tongue that is molded to the heel of the wearer and extends under the heel for further support of the ankle upon hardening. The brace should be able to fit inside an athletic shoe

and is capable of being worn without the brace needed to be held in place by belts or straps (US Patent 5,868,693, 1999).

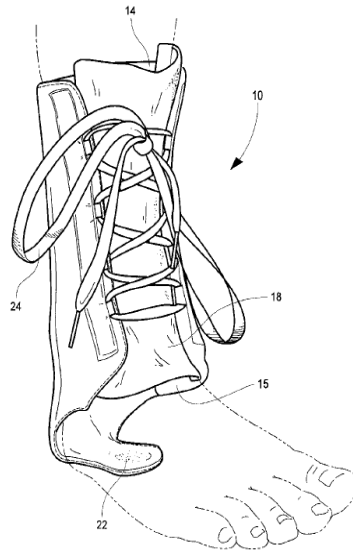

Figure 5: US Patent 5,868,693

Hayashi developed a moldable custom-fitted ankle brace that is constructed out of a heat moldable thermoplastic material. It is formed around the patient's injured ankle and is shaped to have medial and lateral extensions that cover the medial and lateral malleoli of a patient's foot. The brace has both stretchable and non-stretchable straps to hold it in position against the ankle and leg. It can also be held in place using athletic tape. The brace is meant to be comfortable for the user so they can wear it for longer periods of time and during strenuous activities such as sports (US Patent 6,056,713, 2000).

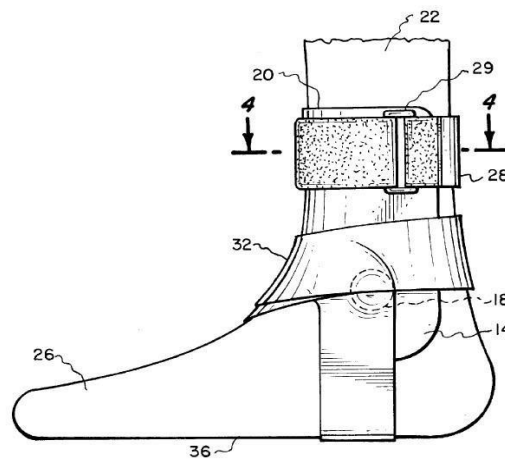

Figure 6: US Patent 6,056,713

Palumbo developed a dynamic ankle brace that used a U-shaped felt pad contoured to fit about the lateral malleolus of the ankle and an elastic strap member connected to the pad that could be wrapped around the foot and ankle to apply pressure to the pad and ankle. This design, which keeps the foot in a position of stability, is used in place of taping as preventative measure against ankle sprains, or for therapeutic purposes. The dynamic ankle brace was developed in order to function with little added discomfort while the user was in motion. The brace has a simple construction, is easy to use, and is relatively simple to manufacture (US Patent 4,495,942, 1985).

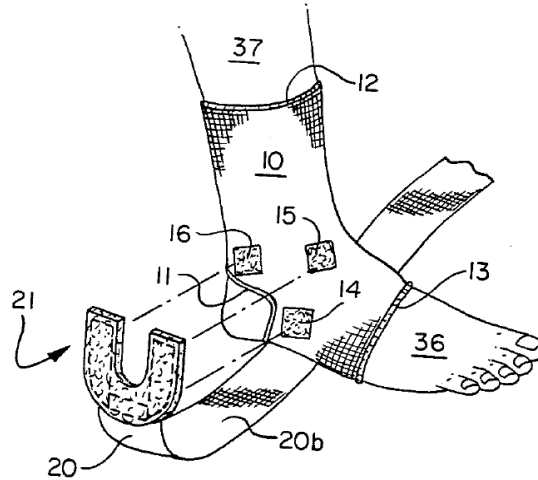

Figure 7: US Patent 4,495,942

Detty developed a universal fit ankle brace that has a base, which is a unitary piece of elastomeric material with an upper portion including a pair of mounting straps and a lower portion including a pair of mounting straps and a pair of short elastic tension straps. The base member is folded to form a jacket and then the straps are wrapped around the lower portion of the leg, the ankle, and the foot while being held in place with VELCRO® fastening components. The amount the tension straps are stretched effects the adjustment of the tension they provide to the brace to stabilize the ankle. The material of the brace provides both cushioning and thermal retention properties (US Patent 5,472,414, 1994).

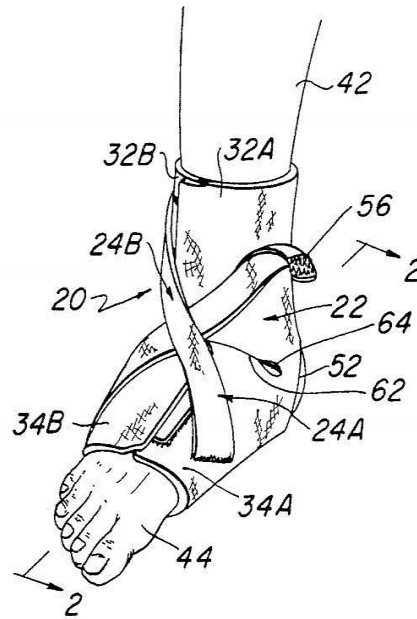

Figure 8: US Patent 5,472,414

## 2.8. Ankle Strength

The hinge joint of the ankle receives relentless strain during physical activities; because of this, ankle ligament injuries are the most commonly occurring soft tissue injury, especially for athletes. Sprains occur when the ankle is either subjected to sudden forces or is forced to move beyond its range of motion (Munn, 2013). The most common ankle injury is inversion, this is when the subtalar joint exceeds 30 degrees of inversion (What is the subtalar joint, 2013). The ankle being the lowest lower body joint receives more pounds of pressure from the body during loading than the hip and knee which is another reason ankle injuries are more common than injuries to the other two joints (Ubell, 2003). Although there are ways to increase ankle strength, many athletes use ankle braces in order to prevent or to recover from ankle injuries.

Ankle injuries among athletes have become so common that athletes have begun wearing ankle braces as a preventative measure in order to increase the strength and stability of their ankle and reduce the risk of sprains. In 2012, a study tested the effect of lace-up ankle braces on injury rates of high school football players. They found that wearing braces is effective in preventing ankle sprains but does not reduce the severity of the sprains that do occur (McGuine, 2012). Ubell et al. also found similar results in their study which tested whether or not ankle braces have a significant effect on decreasing the risk of inversion forces during falling. They discovered that out of the three ankle braces they tested: lace up Swede-O, Aircast, and Bledsoe, only the last two had a significant effect in reducing inversion compared to the no-brace baseline (Ubell, 2003). These studies show

that although braces do have an impact, the reduction of ankle injuries the extent of the impact differs from brace to brace.

## 2.9. Testing

In order to determine the effect each individual brace has on increasing ankle stability, many different types of tests have been created. The three most common types of ankle stability tests are: center of pressure and error score testing, passive stability testing, and rapidly induced stability testing. Each of these types of ankle testing is designed in order to analyze the stability of the ankle and the effect a brace has on that stability compared to a no-brace baseline test.

Center of pressure and error score testing is a low risk way to test ankle stability before subjecting an individual to more testing on their ankle. For these tests the subject stands on a force plate which measures the reaction force generated by the weight of the body. The individual must stand in the given starting position. While in this position the subjects submit to error score testing where they are asked to remain as still as possible on the plate for a designated period of time and receive points each time they move from the initial starting position. These points are called balance errors, the more balance error points the individual receives the lower strength and stability rating they have. In order to test the effect of ankle braces the subject must complete the test twice. The first time the individual wears only a shoe to get a strength baseline and the second time they wear a shoe and the ankle brace in order to see if there was an increase in stability with the brace (Ross, 2011). This type of testing is effective because it is low risk for the subject and it produces quantitative results from both the force plate and the error point values the subject receives.

Passive stability testing observes the stability of the ankle in an inactive setting. In order to follow through with this, an apparatus must be created to measure the ankle's natural degree of motion. Elis et al. performed comprehensive testing of ten different ankle braces and a custom device was created to test the stability of the ankle joint in three planes. To determine range of motion and torques the ankle was fixed in the device (Figure 9) and then rotated in each direction to the limits of the individual's comfort.



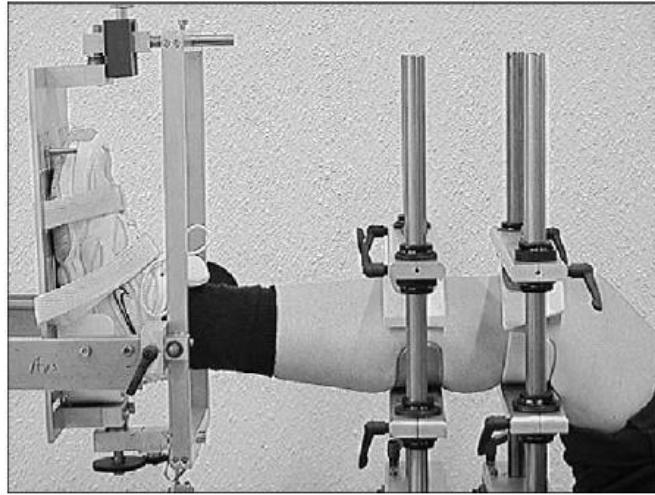

Figure 9: Passive Stability Testing

The degree of motion was recorded using potentiometers fixed to the axes and the torques were recorded using torque wrenches (Elis, 2002). This is only one type of passive testing but it is effective because it allows for the collection of quantitative torque and degree of motion data. Although passive testing is an effective way of determining the degree of ankle motion, it has its limits because it is not similar to active motion due to no load being applied to the ankle. Rapidly induced stability testing is a high-risk way of testing because it involves testing the ankle while the subject is moving and the load of the subject's body is applied. To conduct this test, an apparatus needs to be set up to induce inversion or eversion so that the subject's rapid stability ankle response can be measured. The first example of an apparatus demonstrating this is a trap door apparatus (Figure 10).

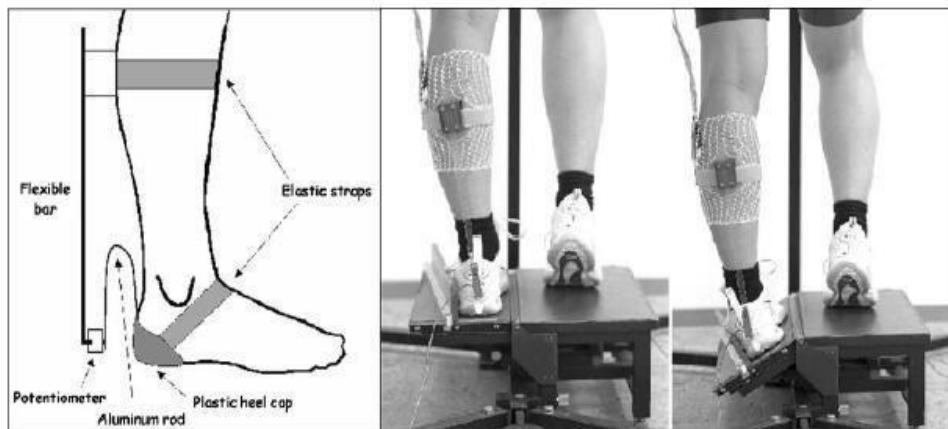
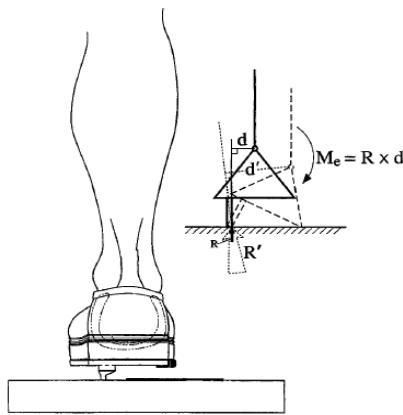

Figure 10: Trap Door Apparatus

In order to test rapidly induced stability, the subject stands on the platform with the leg that is being tested on the hinged trapdoor bearing most of the body's weight. This trap door is held up

by a lock that is released by a solenoid when the tester is ready. When the trap door is released the door drops to an angle of inversion of approximately 25 degrees. A goniometer, which measures angles, is then used to record the hind foot inversion angle inside the shoe (Elis, 2002). Based on the measured angles the tester can then determine the rapidly induced stability of the subject's ankle.

Another apparatus that tests rapidly induced stability of an ankle is a detachable sole. A study was conducted in which a detachable sole was connected to a subject's shoe in order to test the stability of the individual's ankle. This sole was made of aquaplast and heat molded to fit a shoe. On the bottom of the sole, approximately 20mm right of the midline running the length of the shoe, they placed a 6mm wide and 27mm high fulcrum. This fulcrum, when the individual lands on that foot, caused induced dynamic inversion of the ankle joint of up to 24 degrees if the outer part of the shoe hits the ground (Figure 11).



**Figure 11: Force Diagram for Detachable Sole Apparatus**

Using this apparatus they were able to test the subject's ability to prevent ankle inversion with minimal risk to the subject because ankle injuries normally occur only after approximately 30 degrees of inversion (Ubell, 2003). Shown in Figure 12, another study also used a similar detachable sole design to measure ankle inversion. They listed the same procedure as the previous experiment but created their sole out of orthoplast and used a fulcrum that was 30 mm high to create an inversion angle of 25 degrees when testing (Knight, 2012).



Figure 12: Detachable Sole Apparatus

## 2.10. Ankle and Brace Analysis

### 2.10.1. Ligament Analysis

The anterior talofibular ligament (ATFL) and the calcaneofibular ligament (CFL) are the most commonly injured ligaments during an inversion ankle sprain. A typical stress strain curve for ligaments is shown in Figure 13.

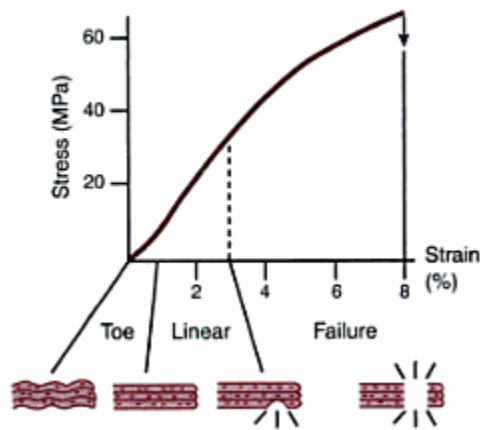

Figure 13: Stress-Strain Curve for Ligaments

As can be seen, in the toe region the collagen fibers of the ligament are wavy. As the linear region is reached the fibers straighten out. Collagen fibers begin to tear in the plastic region until eventually the ligament reaches failure and completely tears (Hamill, 2009). In order to prevent this from happening, ankle braces were developed to help support the ankle and keep the ankle within a 30° range of motion. An analysis of brace stability is done below by investigating the forces a ligament can withstand and how they are affected by the addition of a brace.

A schematic of the lateral view of the ankle showing the major ligaments can be seen below.

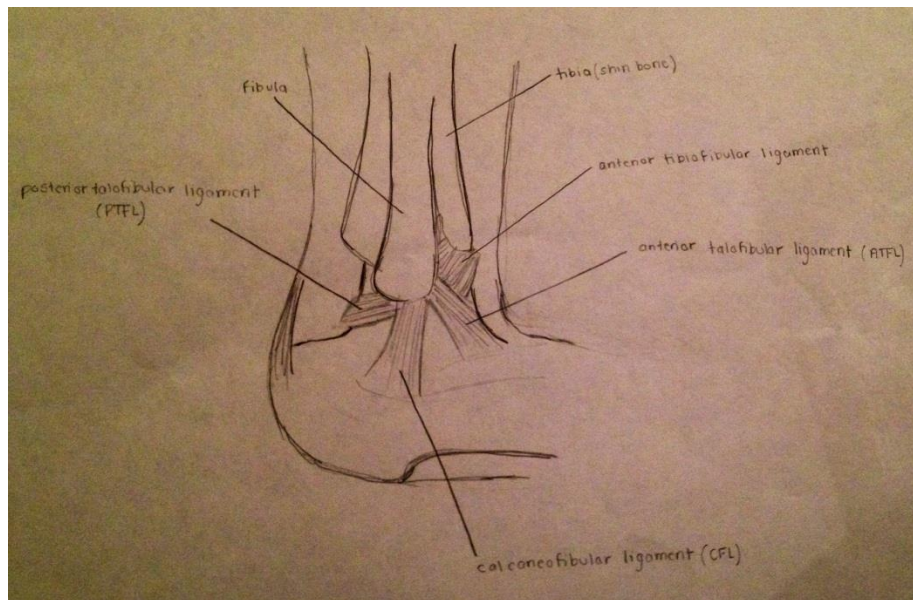

Figure 14: Lateral View of the Ankle

The schematic is then simplified into a free body diagram representing only the ATFL and CFL with no forces or torsion applied. The fibular malleolus, or fibula, is represented by segment AB, the talus is represented by segment CD, and the calcaneus is represented by segment EF. Both the ATFL and CFL are assumed to be springs with a stiffness of variable  $k$ .

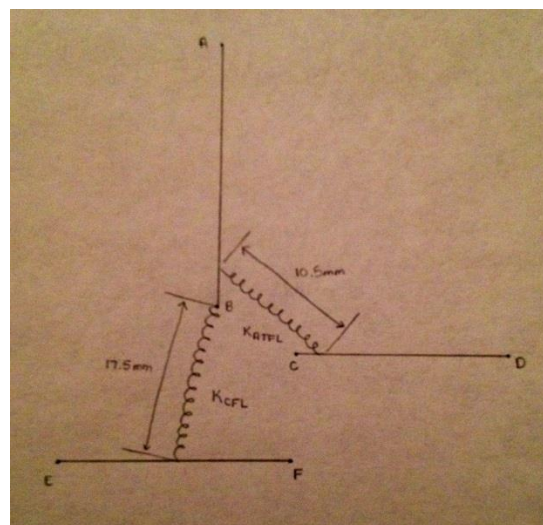

Figure 15: FBD of ATFL and CFL Modeled as Springs

The forces the anterior talofibular ligament and calcaneofibular ligament can withstand vary within a wide range depending on the individual and study conducted. Therefore, for the following analysis, the values summarized in Table 1 below were taken directly from literature to represent the ATFL and CFL.

Table 1: Literature Values for the ATFL and CFL

Ligament	Ligament Length (mm)	Maximum Tensile Force (N)	Elastic Modulus (N/mm <sup>2</sup> )	Cross Sectional Area (mm <sup>2</sup> )
ATFL	10.5	396	48.36	12.9
CFL	17.5	642	173	9.7

As noted, the anterior talofibular ligament can sustain a tensile force of about 396N and the calcaneofibular ligament can sustain a tensile force of about 642N (Tran, 2013). If the ankle support allows for tensile forces in the ATFL and CFL ligaments to reach numbers greater than those stated the ligaments will fail causing an ankle sprain.

In order to calculate the forces found in the ligaments of the ankle during the project team's detachable sole testing, which will be discussed further, the following method was used. Schematics of the posterior view of the ankle are shown below, highlighting the calcaneofibular ligament. The first schematic represents an individual standing on a flat surface while the second schematic represents an individual at an inversion angle of 20°.

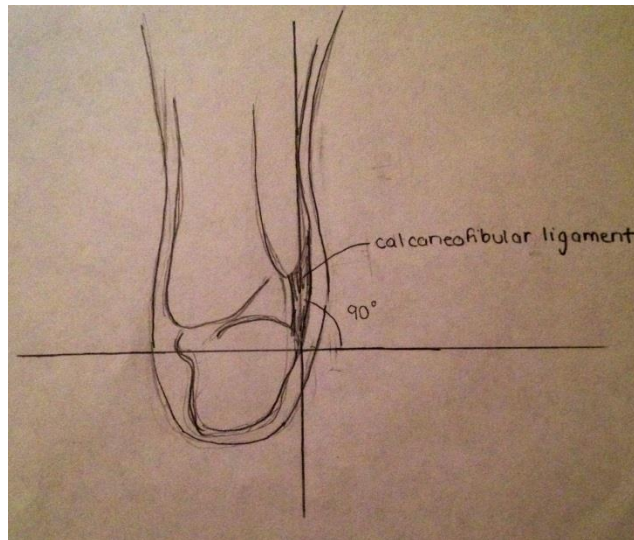

Figure 16: Posterior View of the Ankle when Standing on a Flat Surface

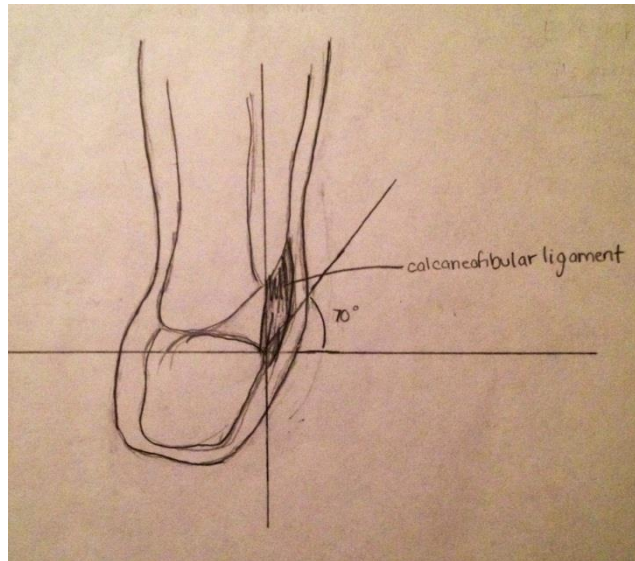
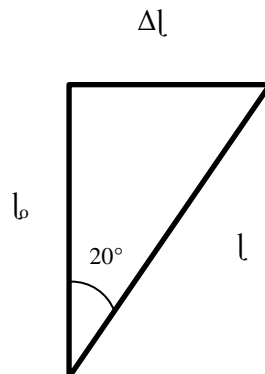

Figure 17: Posterior View of the Ankle at 20 Degree Inversion

In order to calculate the length the CFL stretched during inversion, the above schematics were simplified into basic trigonometry, represented by a right triangle. The length at 20° inversion is expressed as  $l = l_o + \Delta l$ , where  $l_o$  is the original ligament length.



From literature values the original ligament length is assumed to be 17.5mm (Corazza et al., 2003).

The ligament extension length is then calculated using the following equation:

$$\tan\theta = \frac{\Delta l}{l_o}$$

$$\tan(20) = \frac{\Delta l}{17.5}$$

$$\Delta l = 6.37\text{mm} = 6.4\text{mm}$$

Therefore, the length at 20° inversion is  $l = \Delta l + l_o = 6.4 + 17.5 = 23.9\text{mm}$ . Strain of the calcaneofibular ligaments is then calculated using the following equation:

$$\varepsilon = \ln\left(\frac{l}{l_0}\right) = \ln\left(\frac{23.9}{17.5}\right) = 0.31$$

From literature values, the elastic modulus of the CFL is assumed to be 173 N/mm<sup>2</sup> (Corazza et al., 2003). Stress in the CFL is then calculated using the following equation:

$$E = \frac{\sigma}{\varepsilon}$$

$$173 = \frac{\sigma}{0.31}$$

$$\sigma = 53.63 \frac{N}{mm^2}$$

The cross sectional area of the calcaneofibular ligaments is assumed to be 9.7mm<sup>2</sup> from literature values (Corazza et al., 2003). The tensile force on the CFL was then calculated as follows:

$$F = \sigma A = 53.63 (9.7) = 520.2N$$

Since ligaments can be modeled as springs, the stiffness constant of the CFL is calculated using the following calculation:

$$F = kx$$

$$520.2 = k(6.4)$$

$$k = 81.4 \frac{N}{mm}$$

In order to calculate the forces found in the anterior talofibular ligament, a schematic of the anterior view of the ankle can be seen below.

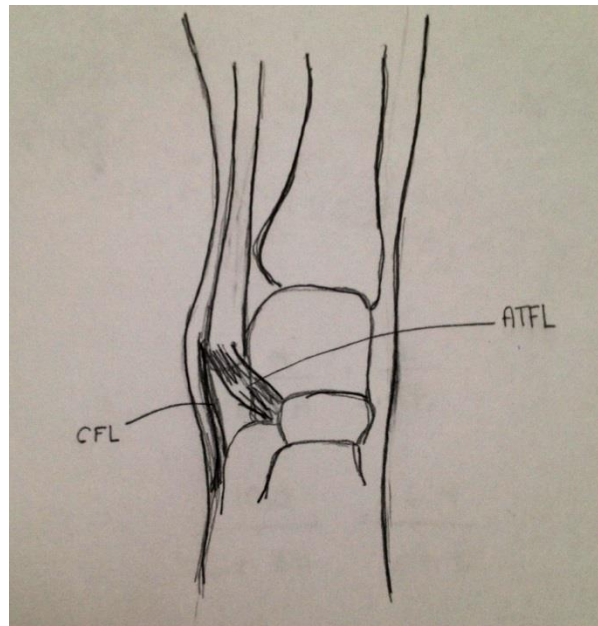
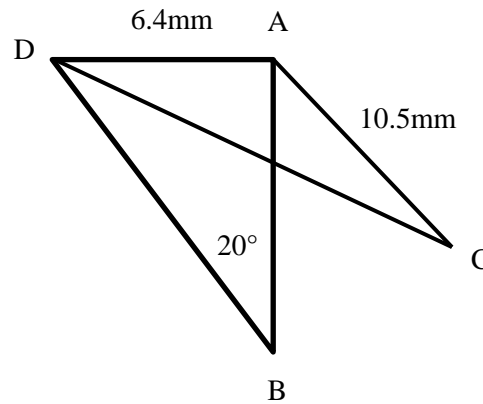
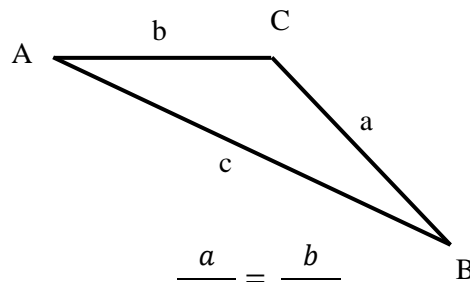

Figure 18: Anterior View of the Ankle

This schematic was then simplified and the law of sines was used to find the overall extension of the ATFL at 20° inversion. The CFL in a flat stance is represented by segment AB while the ATFL is represented by segment AC. At 20° inversion, the CFL will stretch as described above. Angle ADC is assumed to be half of angle ADB; therefore, it is a 35° angle.



Segment DC above represents the length of ATFL at full extension when at 20° inversion and is calculated as follows:



$$\frac{a}{\sin A} = \frac{b}{\sin B}$$

$$\frac{10.5}{\sin 35} = \frac{6.4}{\sin B}$$

$$B = 20.5^\circ$$

$$C = 180^\circ - 20.5^\circ - 35^\circ = 124.5^\circ$$

$$\frac{10.5}{\sin 35} = \frac{c}{\sin 124.5}$$

$$c = 15.1\text{mm}$$

$$15.1\text{mm} - 10.5\text{mm} = 4.6\text{mm}$$

Therefore, the ATFL extends ( $\Delta l$ ) 4.6mm when inverted to an angle of 20°. The strain is then calculated using the following equation:

$$\varepsilon = \ln\left(\frac{l}{l_0}\right) = \ln\left(\frac{15.1}{10.5}\right) = 0.36$$



From literature values, the elastic modulus of the ATFL is found to be 49 N/mm<sup>2</sup> (Corazza et al., 2003). The stress is then calculated using the following equation:

$$E = \frac{\sigma}{\varepsilon}$$

$$49 = \frac{\sigma}{0.36}$$

$$\sigma = 17.8 \frac{N}{mm^2}$$

The cross sectional area of the anterior talofibular ligaments is assumed to be 12.9mm<sup>2</sup> from literature values (Corazza et al., 2003). The tensile force the ATFL can withstand is then calculated using the following equation:

$$F = \sigma A = 17.8 (12.9) = 229.65N$$

The stiffness constant of the ATFL is then calculated.

$$F = kx$$

$$229.65 = k(4.6)$$

$$k = 49.92 \frac{N}{mm}$$

A ratio of extension to stiffness was compared between the calcaneofibular ligament and the anterior talofibular ligament in order to determine which ligament was stiffer.

$$\frac{\text{extension of CFL}}{\text{stiffness of CFL}} = \frac{\text{extension of ATFL}}{\text{stiffness of ATFL}}$$

$$\frac{6.4}{81.4} = \frac{4.6}{49.92}$$

$$0.079 = 0.092$$

Therefore, the ATFL tends to fail first during an inversion injury. As stated previously, the average angle the ankle can withstand for an inversion injury is 30°. The above calculations were repeated for both the CFL and AFL in order to see what the maximum amount of tensile force the ligaments can withstand. Calculations done for the CFL are as follows:

$$\tan\theta = \frac{\Delta l}{l_o}$$

$$\tan(30) = \frac{\Delta l}{17.5}$$

$$\Delta l = 10.1mm$$

$$\varepsilon = \ln\left(\frac{l}{l_o}\right) = \ln\left(\frac{27.6}{17.5}\right) = 0.46$$

$$E = \frac{\sigma}{\varepsilon}$$

$$173 = \frac{\sigma}{0.46}$$

$$\sigma = 78.84 \frac{N}{mm^2}$$

$$F = \sigma A = 78.84 (9.7) = 764.8N$$

Therefore, the maximum force the CFL should be able to withstand before failure would be 764.8N. Calculations were then repeated for the ATFL and are as follows:

$$\frac{a}{\sin A} = \frac{b}{\sin B}$$

$$\frac{10.5}{\sin 30} = \frac{10.1}{\sin B}$$

$$B = 28.7^\circ$$

$$C = 180^\circ - 28.7^\circ - 30^\circ = 121.3^\circ$$

$$\frac{10.5}{\sin 30} = \frac{c}{\sin 121.3}$$

$$c = 17.9mm$$

$$17.9mm - 10.5mm = 7.4mm$$

$$\varepsilon = \ln\left(\frac{l}{l_0}\right) = \ln\left(\frac{17.9}{10.5}\right) = 0.53$$

$$E = \frac{\sigma}{\varepsilon}$$

$$49 = \frac{\sigma}{0.53}$$

$$\sigma = 26.14 \frac{N}{mm^2}$$

$$F = \sigma A = 26.14 (12.9) = 337.18N$$

Therefore, the maximum tensile force the ATFL would be able to withstand during an inversion injury would be 337.18N. Values calculated for both the CFL and ATFL are similar to those found in the literature.

### 2.10.2. Brace Analysis

In order to analyze the affects a brace has on the ankle, the maximum moment the ankle can withstand during an inversion injury is compared to the allowable moment offered by a brace. A schematic of the posterior view of the ankle is shown below with ankle supports, similar to the plastic inserts found in the project team's prototype. These supports were assumed to be fixed at both ends.

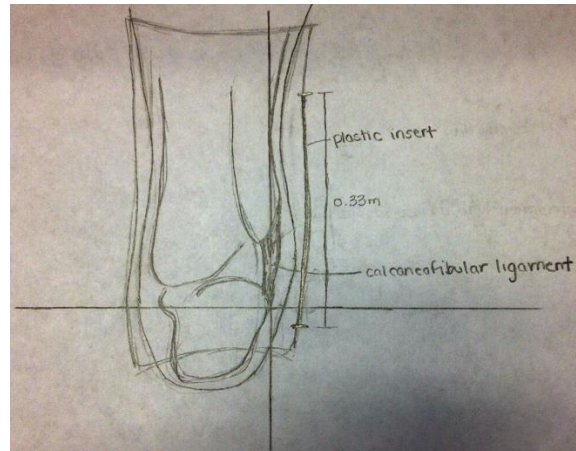
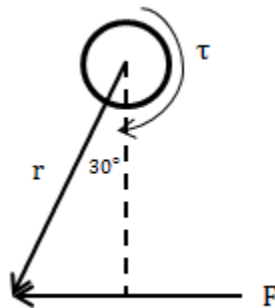

Figure 19: Posterior View of the Ankle with Ankle Support

A torque diagram was drawn in order to calculate the ground reaction force during an inversion ankle sprain. The maximum angle of  $30^\circ$  inversion was used as well as the maximum torque of 45 Nm that can be applied to the ankle before failure. In the following diagram,  $F$  is the ground reaction force on the outside portion of the heel and  $r$  is the radius from the axis of rotation to the force applied. The radius is equal to the measured length from the ankle joint to the outside of the heel, which is equal to 2in or 0.0508m. Torque is applied about the subtalar joint.



The ground reaction force is then calculated as follows:

$$\tau = rF\cos\theta$$

$$45 = (0.0508)F\cos(30)$$

$$F = 1022.9 \text{ N}$$

Therefore, it would take a force of 1022.9N applied to the outside portion of the heel in order to create a large enough torque to cause failure of the ankle. This force is assumed to be the same amount of force that is applied to the brace during a  $30^\circ$  inversion injury. As stated before, the plastic inserts in the project team's prototype used for high support are assumed to be fixed at both ends. A free body diagram is drawn below showing the forces acting on the polycarbonate inserts.

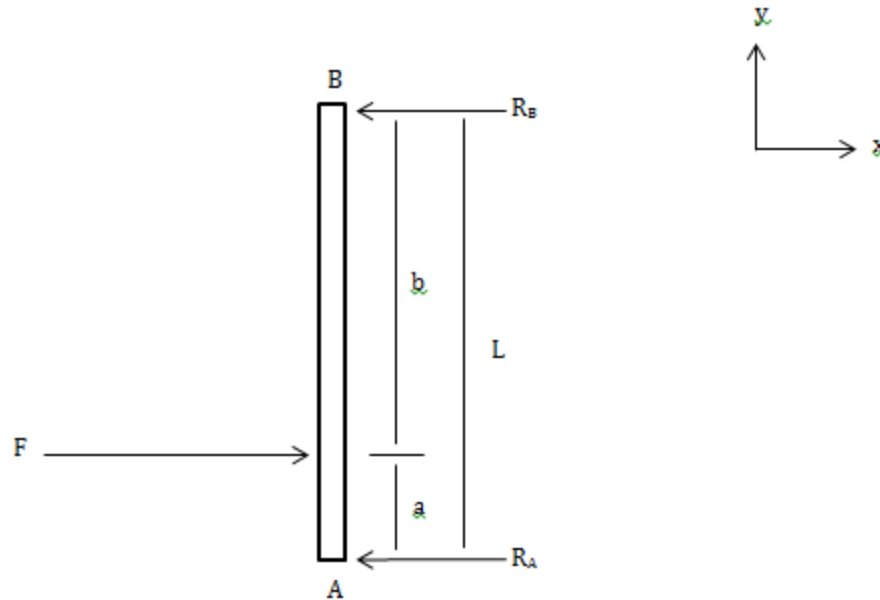

Based on the size of the inserts and where the ankle joint is located, length  $b$  is assumed to be 11 in or 0.2794m, length  $a$  is assumed to be 2 in or 0.0508m, and the total length  $L$  is assumed to be 13 in or 0.33m. The reaction forces are then calculated using sum of the forces and sum of the moments as follows:

$$\sum F_X = 0 = F - R_A - R_B$$

$$\sum M_A = 0 = R_B L - F a$$

$$\frac{F a}{L} = R_B$$

$$\frac{1022.9(0.0508)}{0.33} = R_B$$

$$R_B = 157.5N$$

Therefore,  $R_A$  is equal to:

$$1022.9 - 157.5 = R_A$$

$$R_A = 865.4N$$

These forces create a bending moment; therefore, methods of sections were used to find this moment as well as the ultimate stress of the polycarbonate plastic. The method of sections diagram can be seen below.

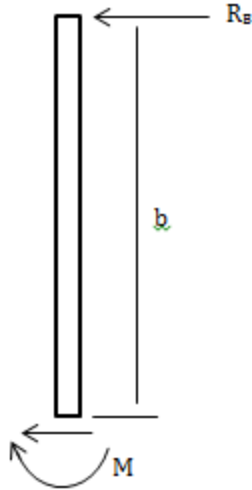

Therefore, the moment is equal to:

$$M = R_B b = 157.5(0.2794) = 44Nm$$

The ultimate stress is then calculated and compared to literature values to see if the brace would fail under a moment of this size. Ultimate stress is calculated using the following equation; where M is the bending moment, y is the distance from the neutral axis, and I is the moment of inertia.

$$\sigma = \frac{My}{I}$$

The moment of inertia is calculated using the following equation:

$$I = \frac{bh^3}{12}$$

The following diagram gives us the base and height of the rectangular inserts. As can be seen, b is equal to 0.002m and h is equal to 0.0508m.

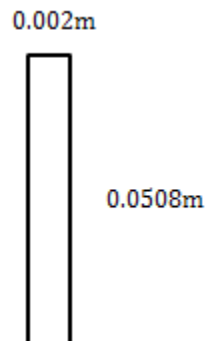

Therefore, moment of inertia is equal to  $2.2 \times 10^{-8} m^4$ . The distance from the neutral axis would be half of 0.002m, or 0.001m. Ultimate stress is then calculated as follows:

$$\sigma = \frac{(44)(0.001)}{2.2 \times 10^{-8}}$$

$$\sigma = 2013783.5 \text{ N/m}^2 = 2.01 \text{ MPa}$$

According to literature values, the ultimate stress polycarbonate plastic can withstand is 65 MPa ("Lexan® PolyCarbonate Plastic," 2008). Therefore, since the ultimate stress under these loads is much smaller than the allowable stress the ankle brace would not fail. The moment the ankle brace would be able to withstand is calculated below.

$$\sigma = \frac{My}{I}$$

$$65000000 = \frac{M(0.001)}{2.2 \times 10^{-8}}$$

$$M = 1430 \text{ Nm}$$

Therefore, in order for the ankle brace to fail causing an inversion ankle sprain, the ankle must withstand a moment of 1430Nm. Based on these calculations; braces do have a stabilizing and supportive effect on the ankle.

### 3. Project Strategy

#### 3.1. Initial Client Statement

As stated previously, ankle sprains have an incident rate of about 2.15 sprains per 1,000 people each year. This is a total of roughly 680,000 ankle sprains in the United States in one year. In response to this, athletes all over the country rely on ankle supports and braces to help recover from or prevent these injuries. However, individuals become extremely dependent on braces and end up relying on the brace instead of their own ankle strength. This concept is known as brace overuse. Many braces also restrict the ankle motion more than necessary. In addition to becoming too dependent on a brace, it can cause tissue atrophy in the ankle joint and can decrease the ankle's ability to restrict excessive ranges of motion when not braced.

Wearing braces can also affect the energy absorption of the ankle, knee, and hip. Many athletes who wear ankle braces tend to develop knee problems further down the road due to the 10% increase in twisting forces on the knee. In order to attempt to prevent these problems, an adjustable ankle brace that can be used for the different stages of ankle healing has been proposed. The initial client statement is as follows:

*To develop an adjustable ankle brace for athletes that would allow for different stages of ankle healing.*

#### 3.2. Objectives

Objectives are defined as the expressions or attributes and behavior that the client or potential users would like to see in the designed system or device (Dym & Little, 2009). After attaining a general knowledge of ankle braces and the problems associated with them, the project team was able to come up with an extensive list of design objectives.

First, the ankle support should be user friendly. This means that the device should be both comfortable and easy to use. If the ankle support is not comfortable, athletes will not be interested in purchasing the device since it could potentially further injure the individual's ankle or drastically affect their ability to participate in their sport. The ankle support should be easy to use in the sense that it should be relatively easy to put on and take off. The device should not be a hassle to put on, especially if used on a daily basis.

Secondly, the device should also be effective. This means that the device should be able to perform all of its functions consistently and without failure. The ankle support should be durable, stable, mobile, and adjustable. The device should be durable in the sense that it will last at a relatively long time and won't begin to break down and wear away after the first use. The ankle support should also be stable, meaning that it will prevent inversion and eversion of the ankle and

will not give out when put under relentless stress and strain while being worn during physical activity. The device should be mobile, allowing the ankle to have a certain range of motion based on the recommended guidelines developed by the project team. The device must be adjustable to cover the different stages of ankle healing as defined by the project team.

The ankle support should also be marketable. In order to be marketable, the product should be aesthetically pleasing, meaning it should appeal to customers, and have a reasonable cost in order to be competitive within the market.

The project team's objective tree shows how the objectives relate to each other (Appendix B). The three main objectives are for the ankle support to be user friendly, effective, and marketable. From there, the sub-objectives split off each main objective. In the case of the sub-objective of cost, it can be further broke down into consumer cost and producer cost. A pairwise comparison chart shows the ranked order of the first set of sub-objectives (Appendix C). Stable and mobile are at the top of the objectives list followed by, adjustable, durable, easy to use and comfortable, cost, and then finally aesthetics.

### **3.3. Constraints**

Constraints are defined as restrictions or limitations on a behavior, value, or some other aspect of a designed object's performance (Dym & Little, 2009). The design team has specified both project constraints and design constraints that are stated and described in this section. Two of the main project constraints restricting the project team are time and cost. The design must be completed and tested within 28 weeks. This includes the amount of time to design, test, create a prototype, and compile a report, as well as present findings and recommendations. As for cost, the project team was allotted \$160 budget for each person in the project team, totaling an amount of \$800. This money is used to build testing mechanisms for the ankle support as well as construct a prototype.

The first design constraint states that the ankle support must limit the ankles natural range of motion. The support must keep the ankle within a 30° natural range of motion for inversion and a 5° natural range of motion for eversion. The ankle support must also keep the ankle from sustaining a torque greater than 45 Nm. If the support allows for more ankle movement than specified an injury could potentially occur.

The second design constraint states that the ankle support must prevent the anterior talofibular ligament from sustaining a tensile force of about 396N and the calcaneofibular ligament from sustaining a tensile force of about 642N. If the support allows for tensile forces in the anterior



talofibular ligament and the calcaneofibular ligament to be greater than those stated, than the ligaments will fail causing an ankle sprain.

The third design constraint states that the ankle support must work on both left and right ankles. Individuals are capable of spraining either, or both ankles, so in order to be an effective design the project team must take in to consideration that the brace has to be able to be replicated for use on the other ankle.

The fourth design constraint states that the ankle support must be universal. Both males and females are capable of spraining their ankles so the design must be able to ensure the same stability for the ankles of both males and females. Since the project team is focusing on individuals between the ages of approximately 15 and 35 years, the ankle support must also be able to fit and provide stability to any individual within that age range.

The fifth and final design constraint states that the ankle support system must cost less than \$100. In order to be competitive in the market the ankle support has to be sold to consumers at a reasonable price.

### **3.4. Revised Client Statement**

After taking into consideration the objectives and constraints, the project team revised their initial client statement. While the initial client statement was vague and included little detail, the revised client statement fully encompasses all of the aspects the design should include.

*The objective of this project is to design, create, and test an ankle support system for athletes. The ankle support should prevent inversion and eversion of the ankle while keeping the ankle within the 30 natural degrees of motion the ankle can rotate. It should be adjustable to allow for different stages of ankle healing as defined by the project team. The ankle support can be a new design or a modified version of a current ankle support. The support will either need to match or exceed the comfort, ease of use, and range of ankle mobility of current gold market standard ankle braces. The device must be durable and able to withstand the forces put on it from physical activity and the wearer's shoe. The ankle support should be marketable in the sense that it is priced reasonably to be competitive in the market, is innovative, and is aesthetically pleasing.*

The revised client statement includes a lot more detail and is much more informative than the initial client statement. It touches upon each of the objectives defined by the project team as well as the degree of motion the ankle can rotate before injury occurs.

### 3.5. Project Approach

The project approach is split into three parts; the technical approach, the management approach, and the financial approach. The technical approach discusses project challenges and how they were addressed as well as how the project team conducted their project. The management approach will review the work breakdown structure and a timeline the project team followed in order to stay on task. The financial approach will discuss projected prototyping expenses, testing apparatus expenses, manufacturing costs, and consumer costs.

#### 3.5.1. Technical Approach

The project team completed an extensive amount of background research in the areas of ankle anatomy, sprain types and grades, history of sprains in sports, precautionary measures, current products, patents, problems with ankle braces, and testing measures. This background research helped prepare the team to make educated decisions when it came time to test and design a prototype. However, some information was not found in the literature; therefore, the team had to make educated decisions based on their engineering background as well as interviews and discussion with professionals within the field of study such as professors and athletic trainers.

The project team also created several free body diagrams of the foot and ankle in order to fully understand the strength of the ankle (Appendix D). Different views of the ankle include standing with the weight on one foot, standing in dorsiflexion, standing with a foot in the air, and hind view of the foot showing inversion and eversion of the ankle. The equations used to find the forces on the joints, ligaments, and Achilles tendons are shown in Appendix E.

After getting IRB approval, the project team was able to begin conducting their preliminary and rapidly induced stability testing. Research participants were recruited through an email that was sent out to Worcester Polytechnic Institute undergraduate students (Appendix F). A population of eight male and twelve female students was recruited in order to gather enough data to make a reasonable comparison between a non-brace condition and a braced condition. For the braced condition subjects tested with a brace currently on the market as well as with the project team's prototype. Three different tests were conducted throughout the study, preliminary testing, a detachable sole test with a potentiometer, and a detachable sole test with a force plate. Before each testing, test subjects were required to sign an informed consent form that was read over with and signed by one of the student investigators (Appendix G). The informed consent form explained the purpose of the study to the test subject as well as explaining the conditions of participation, including the test subjects right to refuse or withdraw from the study without penalty. Informed consent forms were reviewed before each testing session in order to ensure that informed consent

was an ongoing process. The study was conducted over a two month period, from February 1st to April 1st, in which test subjects were asked to return and complete all three tests.

Preliminary testing was conducted by the investigators in order to judge test subject's ankle stability. Ankle stability was tested by having the test subject balance on a soft foam pad while investigators kept track of errors. Before starting preliminary testing each participant was given a questionnaire in order to collect basic background information including: height, weight, sex, amount of physical activity and history of ankle injury (Appendix H). In order to protect the privacy of the test subjects, each individual was given a subject number. This number was recorded on the questionnaire and on all other data collection sheets insuring the subject's anonymity. Only the primary investigator and student investigators had access to the list of student names corresponding to these subject numbers. However, this information was kept confidential and any publication or presentation of the data did not identify the test subjects, as stated by the informed consent forms.

The second part of the questionnaire was filled out by the investigators (Appendix I). Before testing began, the test was thoroughly explained to the test subjects so any questions could be answered and clarifications could be made. At least three investigators were present during testing and out of these investigators two collected data for each test subject. The data was averaged in order to finalize their score. To begin the test, the subject stood on the foam pad without shoes. The test subject was instructed to assume the initial starting position which involved putting their hands on their hips, closing their eyes, and lifting one leg slightly off the ground, while balancing on the other leg. They attempted to remain in this position for one minute while the investigators marked down a single tally for every error that occurred during that time. The errors, which are listed on the questionnaire, include: removing their hands from their hips, lifting the forefoot of the heel, opening their eyes, touching non-weight bearing foot on the ground, and remaining out of position for more than five seconds. Test subjects received only one error score mark, or tally for each error. If multiple errors happened at the same time the subject received only one tally for the first error. The investigators then waited until the subject was back in the initial starting position before continuing to look for errors. At the end of the test the investigators determined the total error score by summing up the error tallies. Each test subject went through two trials and received two total error score values that were averaged to determine their overall error score. The test was conducted again while the subject was wearing a "gold standard" brace and again while wearing the project team's prototype in order to provide a comparison between the non-braced and braced condition. Based on the error score the test

subject received, the investigators determined whether the individual was suited for further testing. If a test subject's overall error score was over 30 their ankle exhibited very little stability and therefore the subject was no longer a good candidate for other testing being conducted by the investigators. This score was determined because an error score of 60 would require the subject to receive an error mark for every second, therefore a score of 30 would mean the subject was able to remain in the initial starting position for at least 50 percent of the time.

Once the subject successfully completed preliminary testing they tested their ankle stability with and without braces using a detachable sole. With the detachable sole the subject went through two trials for each of the conditions: without a brace, with the McDavid ankle brace currently on the market today, and with the project team's prototype in high support.

In this part of testing the participant attached a detachable sole apparatus to the bottom of their foot; this sole has an off-center fulcrum that is 29.5 mm high which causes the foot to invert at an angle of 20 degrees (Appendix J). This angle is a safe amount for the ankle to invert because it has been shown that the ankle does not receive damage until an inversion angle of 30 degrees (Ubell, 2003). During these trials the subject stepped down onto a force plate from twice the height of that force plate using the foot with the sole attached. The force plate then read the force distribution for that foot and gave the inversion time by listing the time the fulcrum initially hit the force plate and the time that the side of the subject's foot hits the ground. With the information found in these trials the project team determined the stability of the ankle and the braces by the time the ankle took to invert. The longer the ankle takes to invert the more stable the brace or ankle is.

The subject will undergo a secondary stage of testing that will measure the angle of rotation of the ankle using a linear potentiometer with the detachable sole apparatus. The same procedure as above was repeated; however, a potentiometer was attached to the subject's calf and ankle region using an elastic band. As the ankle inverts the potentiometer recorded the angle of inversion from the initial starting angle. Following the procedure of the previous test, the subject went through two trials for each of the conditions: without a brace, with the McDavid brace currently on the market, and with the project team's prototype at high support.

While testing was being conducted, the project team also brainstormed and sketched alternative design ideas. The project team came up with five alternative designs that fit into the objectives outlined earlier. These designs were then compared using a functions means chart. Based on the chart and the project team's knowledge of ankle braces, a final design was chosen and a prototype was built. The prototype then went through the same testing conducted before,

the preliminary testing and the rapidly induced stability testing, on the same group of test subjects. Once data was collected it was analyzed in order to compare the project team's prototype against non-brace use. The prototype was expected to show an increase in stability of the ankle over non-brace use. The prototype was also compared to a McDavid ankle brace currently on the market. It was expected that the prototype would perform as well as or better than the braces currently on the market today.

Based on the information found during testing and in the literature, the project team provided several recommendations and guidelines. Healing stages defined by the project team were used to create guidelines that suggested wearing certain portions of the ankle support as ankle strength increases and healing progresses. One of the project team's recommendations is that users follow these guidelines in order to prevent potential problems such as brace overuse and knee injury. Other recommendations were based off of data collected and observations made during the project.

### **3.5.2. Management Approach**

In order to stay on task, the project team created a Gantt chart (Appendix K). The Gantt chart is a timeline showing the aspects of the project, such as the report, the testing, and the design portions, and when each task will be worked on and completed by. A linear responsibility chart was also created in order to keep track of who in the project team is responsible for each task (Appendix L).

### **3.5.3. Financial Approach**

The project team was given a budget of \$800, or \$160 per person, supplied to them by the Mechanical and Biomedical Engineering Departments of Worcester Polytechnic Institute. Any additional expenses came straight from the project team. The expenses were split up into two parts, the materials needed for testing and the materials needed for the ankle support prototype.

Many of the materials needed for testing were borrowed from the WPI athletic trainers such as the foam pad for the preliminary testing. However, for rapidly induced stability testing, the project team had to buy parts and build the apparatuses by hand. The project team was able to use the force plates available to them in the biomedical engineering labs on campus.

Materials for the ankle support prototype were determined based on readily available and currently used materials. Common materials found in current ankle braces include nylon and Velcro tape, both of which were purchased from online distributors.

Ankle braces currently on the market cost anywhere from about \$20 to \$100. The current gold market standard ASO ankle brace cost roughly \$45 depending on where it is purchased. In

order for the project team's prototype to be competitive on the market, the final price for consumers should be less than \$100. Therefore, the project team had a goal of keeping the cost of their prototype under \$30.

## 4. Alternative Designs

The project team developed several alternative designs in order to fulfill the functions and objectives drawn from the problem discussed in the previous chapters. Described below is the process used to develop the conceptual designs and the decision process that lead to our final design.

### 4.1. Needs Analysis

Currently on the market, there are no ankle braces that can be used for all three severity levels of ankle sprains. Overtime, a patient with a severe ankle sprain could have to buy up to three types of braces for proper ankle recovery which could cost them up to or more than \$70. There is a need in the market for a brace that is adjustable and can be used for all three stages of recovery following a severe ankle sprain. Additionally, many patients who sprain their ankle once often re-sprain it, due to the damage done to the ligaments causing them to stretch out and loosen. This decreases ligament support in the ankle and increases one's chance of re-injury. An adjustable ankle brace would allow the individual to gauge the support needed at any given time and adjust to fit that need without having to buy a new brace.

### 4.2. Functions and Specifications

The purpose of this adjustable ankle brace is to prevent inversion and eversion of the ankle while promoting healing and preventing the occurrence of other injuries due to overuse. In order to achieve these goals, several different functions and specifications must be met. Functions dictate what the device will do, while specifications dictate how the desired functions will be met.

The first function of the device is to prevent inversion and eversion of the ankle. In order to describe exactly how this will be prevented the range of motion of the ankle joint must be fully understood. In order to prevent ankle injury the ankle joint must not exceed a 30° natural range of motion for inversion and a 5° natural range of motion for eversion. If the device were to allow for ankle movement greater than these natural ranges of motion a potential injury could occur.

The second function of the design is to promote healing of the ankle. Research has found that compression can help promote the natural healing process of injuries. It does so by reducing muscle vibration and micro trauma to muscle tissues while holding the ligaments and joint in line for improved efficiency and joint stability. Compression also helps keep the swelling out of the joint while bringing more oxygen and nutrients to any injured area.

The third and final function is to prevent overuse of the brace. When using braces some individuals tend to become reliant on the brace's support which leads to over use. Although the brace does help reduce loads on the ankle these loads are then applied to other areas of the lower limb.

This overuse of braces can lead to other joint issues in the knee or hip. Also overuse of the brace decreases the individual's natural ankle strength overtime. Therefore, the brace must be adjustable to fit different stages of healing as defined by the project team. This would allow the user to decide to add or remove portions of the brace for the level of support they need.

Based on these functions, the team used a morphological chart to determine means in which to fulfill the above mentioned functions. The team brainstormed several different means for each function as shown below.

*Table 2: Morphological Chart*

Function	Means 1	Means 2	Means 3	Means 4
1. Prevent Inversion and Eversion of the Ankle	Plastic/Metal Inserts	Durable Foam Supports	Moldable Thermoplastic	Support Attached to Shoe
2. Promote Healing of the Ankle	Lace-Up	Compression Material		
3. Prevent Injuries due to Overuse of the Brace	Removable/Adjustable Parts			

### 4.3. Conceptual Designs

The most simplistic brace type on the market is one that employs only a lace up technique in order to provide support. These braces are normally made of nylon or a similar material and the laces are normally located on the front of the brace similar to a shoe. The average brace dimensions were determined based on previous brace designs (Figure 20). The total height of these braces was approximately 7.5 inches while the length of the brace above the ankle joint was approximately 4 inches. It was found that the 4 inches was set in order to ensure that the brace went high enough above and below the joint to provide support. Braces also cover approximately 2.5 inches of the sole of the foot, as seen in the side view. This dimension keeps the brace stable while still allowing for foot movement.



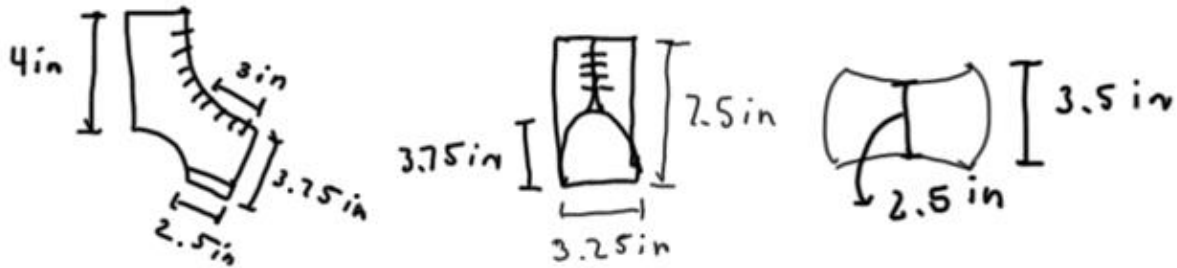

Figure 20: Dimensions of Final Brace showing from left to right: Side View, Front View, and Bottom View

#### 4.3.1. Inserts

Inserts are one method used in braces to stabilize the ankle. This type of brace has pockets that run symmetrically down both sides of the brace with inserts in them in order to provide extra support (Figure 21).

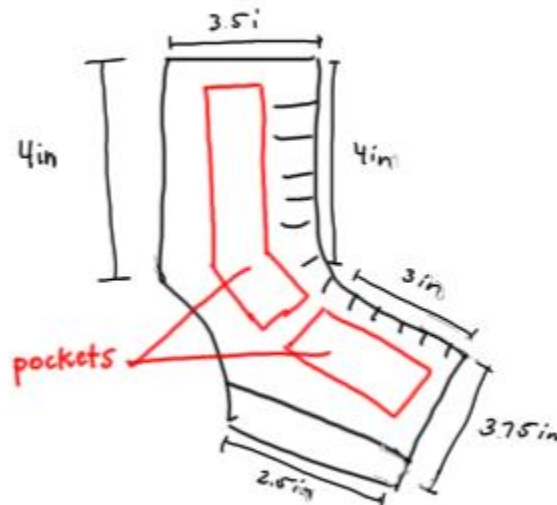

Figure 21: Insert Model of Ankle Brace

These pockets include inserts ranging from gel to solid plastic inserts. The brace stability is then determined by the strength of the insert. Inserts that are stiffer tend to provide greater support to the ankle and therefore are typically used for more serious injuries. The pockets for these inserts are normally sealed off in order to ensure that the insert would not come out or move around while the brace is in use.

#### 4.3.2. Straps

While some modern braces use inserts to provide stability to the ankle, other braces employ a strapping method that mimics the taping technique used by athletic trainers.

The straps originate at the top of the brace, then wrap in a figure eight style around the bottom of the brace and end back at the top of the brace (Figure 22). There are three total straps, one on each side of the brace and then one that wraps around the top of the brace. These straps are usually made by elastic or nylon bands with Velcro covered ends to allow for easy application and adjustability. By wrapping the straps around the ankle it compresses the ankle and stabilizes the joint.

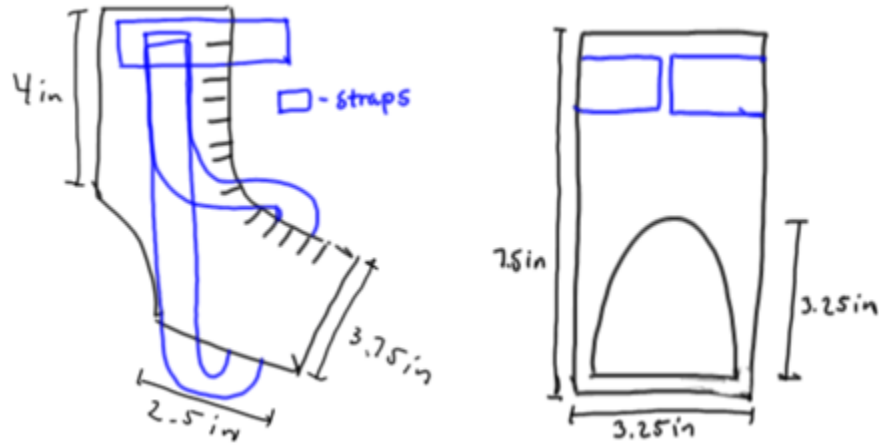

Figure 22: Strap Brace Method

#### 4.3.3. Compression

For less severe ankle sprains, which need minimal support to heal, compression socks are common (Figure 23).

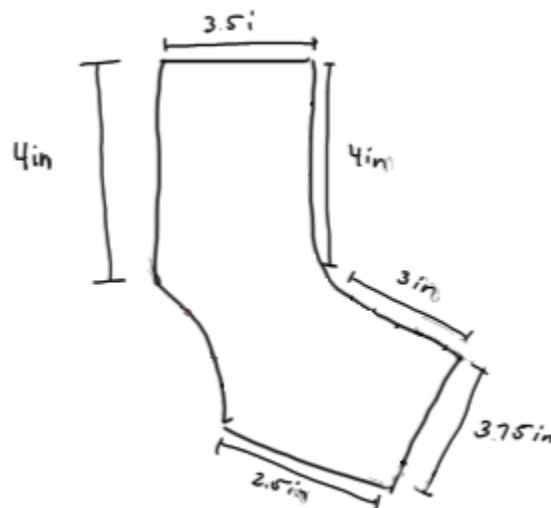

Figure 23: Compression Sock Brace

Compression braces are usually made of materials that are softer and more elastic than nylon. These braces are normally all one piece and are applied by pulling it on the same way one puts on a

sock. Although this model allows for a wide range of motion it does not provide much support. Therefore, the focus is to promote healing while compressing the entire ankle.

#### 4.3.4. Functions Means Chart

The four types of designs discussed above were placed into a function-means chart to allow for qualitative analysis. Based on the function means chart each method of support has both positive and negative aspects to it and all methods are being considered for the preliminary and final designs.

Table 3: Functions Means Chart

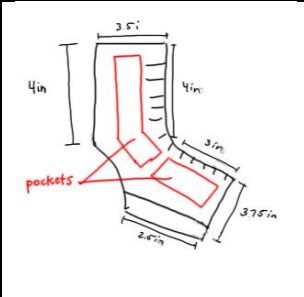
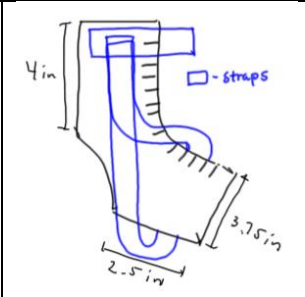
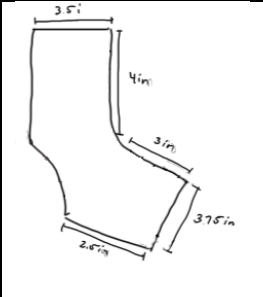
				
	Means			
Function	Lace Up	Inserts	Straps	Compression
Provide Ankle Support	Nylon material provides support while the laces allow for adjustable tightness	Support is added with the type of insert in the brace, the stiffer the insert the more support the brace gives to the ankle	The straps that wrap around the brace increase stability of the ankle joint.	The flexible material and limited stiffness provides little support.
Ankle Compression	The compression can be changed based on the tightness of the laces	This type of brace applies similar compression to the lace up brace method	This type of brace applies similar compression to the lace up brace method but has added compression due to the straps.	The compressive material compresses the ankle while the material flexibility allows for a wide range of motion

#### 4.4. Preliminary/Alternative Designs

##### 4.4.1. Preliminary Design Idea #1: Shoe Brace Design

One initial design idea was to create a shoe with a built in brace in order to provide maximum support to the ankle. By combining the two aspects together the wear that normally occurs between the two parts would be removed and the combination would allow for continuous support from the base of the shoe to the top of the brace. In theory the materials for the shoe would remain the same with the only difference being that the neck of the shoe would extend up to encompass the brace length. The brace aspect would then be integrated into the inner linings of the shoe by adding inserts

down the sides, made of either metal wiring or plastic, to increase stability and nylon mesh weaving to increase compression and support from the sole of the foot to the top of the ankle (Figure 24). Although this design has aspects that are beneficial it did not fit the adjustability requirements that our project was focusing on.

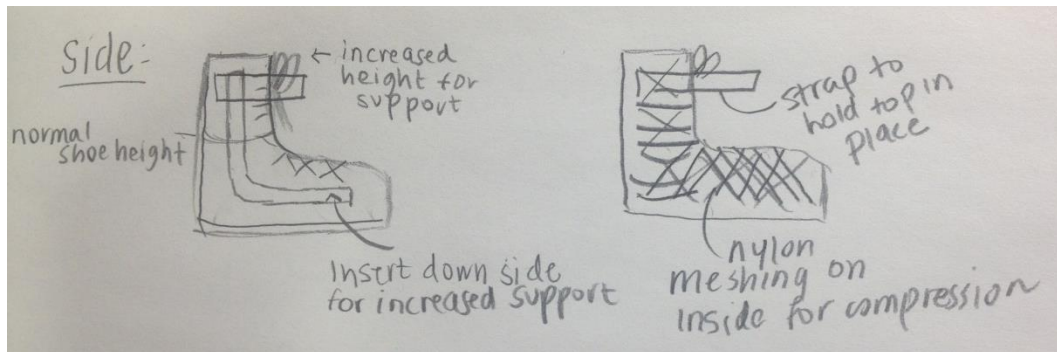

Figure 24: Sketch of Shoe Brace Design

#### 4.4.2. Preliminary Design Idea #2: Alternative Brace

The second preliminary brace idea is a nylon brace. This brace would be one piece with a compressive inside layer and a thicker more restrictive outer layer. The inner compressive layer would then promote healing while the thick outer layer would be used to provide support and increase ankle stability. The laces for this design would not run completely down the front of the brace, as seen in previous designs, instead the laces would start at the top of the brace and stop at the intersect of the foot and the ankle (Figure 25). The foot part of the brace would then be secured using a Velcro strap that wraps completely around the diameter of the foot. This Velcro strap would be of minimal thickness due to its need to fit inside the athlete's shoe. The heel of the ankle would contain a hole in both materials to fit the foot more securely during 360 degrees of motion. For support the vertical piece of the ankle brace would have two pieces of foam sewn into the inner and outer sides. This material would be plush foam of minimal thickness that would cover the ball of the ankle on both sides to reduce the degrees of motion the ankle could encounter. These inserts would not be removable.

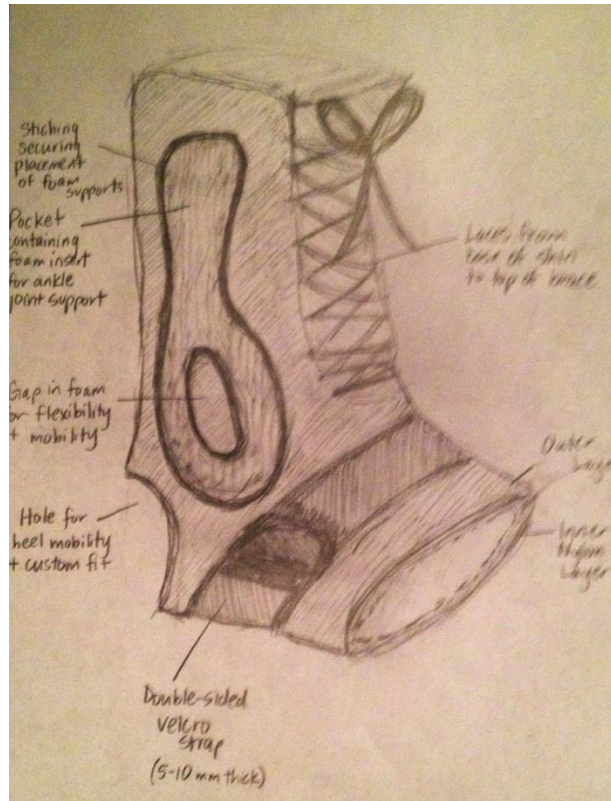

Figure 25: Sketch of Alternative Brace Design

#### 4.4.3. Preliminary Design Idea #3: Moldable Plastic Ankle Support

Another alternative design considered was a moldable thermoplastic ankle support. This brace design has three layers, with parts that can be used interchangeably. As can be seen in Figure 26 below, the first layer consists solely of a compression material (similar to a compression sock). This first, or base, layer would be worn all the time. The second layer is made out of a thermoplastic that can be heated and molded to fit the individual's ankle, similar to a mouth guard. This would allow for a more comfortable custom fit while providing a good amount of support. At first, the molding may need to be done at a doctor's office to get the right fit; however, in the future, we hope to be able to have the individual bring the kit home and mold the thermoplastic themselves. The third and final layer would be a set of figure 8 straps. These straps would provide more compression and stability while holding the thermoplastic layer on. If the individual was feeling better and wanted less restriction, they would be able to interchange the straps and the thermoplastic layer and wear either or, or both, depending on their preference.

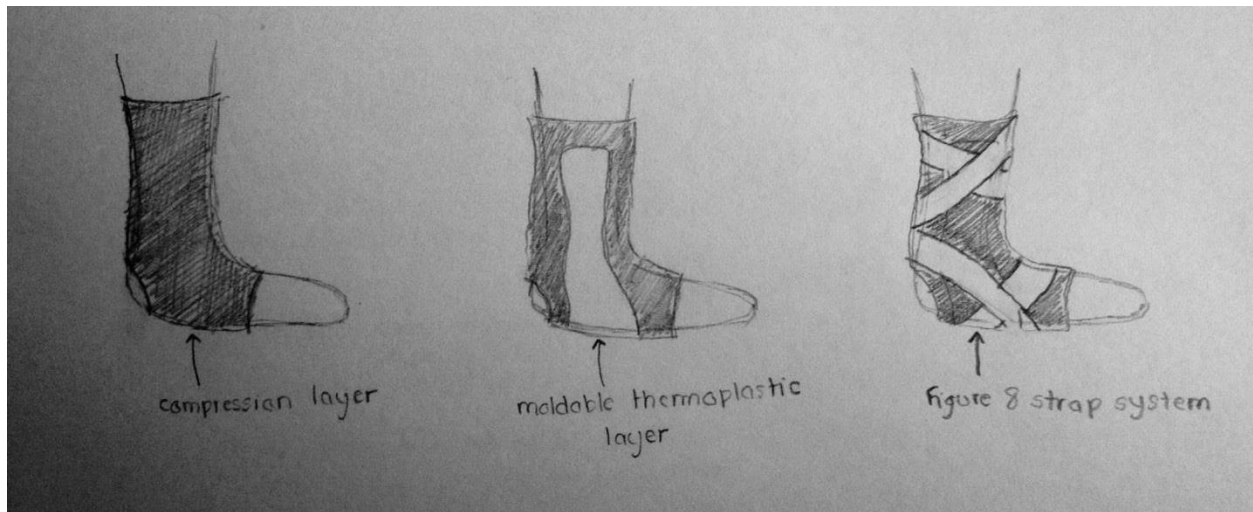

Figure 26: Sketch of Moldable Plastic Ankle Support

#### 4.4.4. Preliminary Design Idea #4: Two Part Ankle Brace

This preliminary design is a two part brace. By adding two layers it increases the brace adjustability because the layers may be worn either together or separately depending on the needs of the individual's ankle at the time. The first, or bottom, layer of the brace would be a compression sock made of a thin and flexible material such as neoprene. This layer provides minimal restriction, and instead compresses the joint which promotes healing. This layer can be worn with the other layer, but it can also be worn alone towards the late stages of healing when only minimal support is needed. The second layer of the brace would be similar to a lace up brace with gel inserts. This layer would be made of nylon mesh and the inserts would run down both sides of the brace for increased support. This layer could then be worn with the first layer for maximum support and compression or alone for medium support and compression.

#### 4.4.5. Preliminary Design Idea #5: Adjustable Ankle Brace

Our final preliminary design contains the most adjustability by combining ideas from all of the conceptual and preliminary designs previously mentioned. This design has one overall layer with parts that can be added or removed for multiple modes of adjustability. The base of the brace design is similar to lace up braces on the market.

The base, made of nylon mesh, includes laces up the front of the brace and pockets that run down both sides. In order to increase compression a compressive layer would be added to the lower half of the brace which would compress the foot and hold the brace in place. This part would be made of F18 neoprene that is approximately 3mm thick. The compression element of the brace provides minimal support while promoting healing and reducing swelling. For further adjustability the pockets on either side will be able to open with slits at the top and the brace would come with

different types of inserts for different stages of healing. These inserts would range from foam which would provide minimal support to plastic which provides maximum support. To make the brace even more adjustable straps will also be included, these straps will attach at the top of the brace to allow for increased support as needed.

#### 4.5. Decisions and Optimization

When looking into the design aspects of our brace, one major factor was the choice of different materials that would be used. Braces that are currently on the market vary in brace style and materials, so the focus was to create a brace using a combination of the current designs and materials. The three stages of rehabilitation that the brace will provide support for are all composed of different materials.

The basic stage of our brace will consist of almost no restrictive devices. It will be a lace up bodice with a Velcro strap along the top ankle opening. The bodice was made out of a high quality ballistic nylon while the Velcro strap is made out of Velstretch, a stretchable breathable material. It will have neoprene pockets sewn onto both sides of the brace, though these will be empty for this stage of rehabilitation. The brace will also have a compression material sewn into the inner lining of the bodice. This material combined with the lace up feature will provide the right fit regardless of the foot dimensions. Another feature we added to our brace was a neoprene foam sewn onto the bottom of the brace. This foam would increase friction between the sole of the shoe and the foot, minimizing the amount of movement of the foot/ankle in the shoe. This feature will maximize the support that the brace can provide while being thin enough to have no effect on the fit of the athlete's choice of footwear.

The second stage of our brace will include additional, detachable straps. These straps will be strung through the laces on the brace and wrap horizontally around the ankle joint on both sides. The horizontal wrap will provide more restriction on the joint compared to a vertical wrap, minimizing the chances of inversion or eversion of the ankle. We used a thin ballistic nylon for the straps and sewed Velcro squares onto both sides to fasten each strap.

The most restrictive stage of the brace will include polycarbonate (Levan) plastic inserts where the width is approximately one half of a centimeter. We chose this plastic due to its average level of flexibility. The plastic can bend slightly to allow very minimal joint movement but it is stiff enough to provide ultimate support. In this stage of the brace both plastic inserts and detachable straps will be used.

## 5. Design Verification

With Institutional Review Board (IRB) approval, preliminary testing and detachable sole testing was conducted on 20 Worcester Polytechnic Institute (WPI) students (12 females, 8 males, age =  $20.95 \pm 1.02$  years, height =  $5.66 \pm 0.34$  feet) who volunteered for this study. Prior to testing, all subjects signed an informed consent approved by the IRB as well as filled out a questionnaire containing information such as age, height, foot size, athletic ability, and history of injuries. The questionnaire can be seen in Appendix H. The subjects were excluded if they had poor ankle stability or injury to lower extremities within the last year.

### 5.1. Preliminary Testing

Preliminary testing was conducted in order to test ankle stability by having the test subject's balance in a specified position on a soft foam pad while the investigators kept track of errors, which are times when the subject moves from the specified position. Test subjects were instructed to put their hands on their hips, close their eyes, and lift their left leg slightly off the ground, while balancing on their right leg. Test subjects attempted to remain in this position for one minute while investigators marked down a single tally for every error that occurred during the time period. The test was conducted without a brace, with a brace currently on the market, and with the project team's prototype in order to provide a comparison between the non-braced and braced conditions.

Throughout each trial the subject's error scores were counted using the Error Score Sheet designed by the project team. On this sheet the tester marks down anytime the subject: puts both feet down, takes their hands off their hips, or opens their eyes. Although error scores are tallied every time they happen if two errors occur at once they are grouped together and counted as one overall error score. The error scores from the trial were then summed and then averaged between the testers to give the total error score for that subject and trial. The max error score was determined to be 30 errors, if a subject was found to have an error score above 30 they were disqualified. This disqualification was set in place in order to ensure that individuals with weak ankles are not subjected to the rest of the tests that could possibly irritate or injure their ankles.

Once testing was completed the overall error scores were entered into Excel where they were then averaged by trial in order to analyze and compare the average error scores for all the trials (Figure 27).



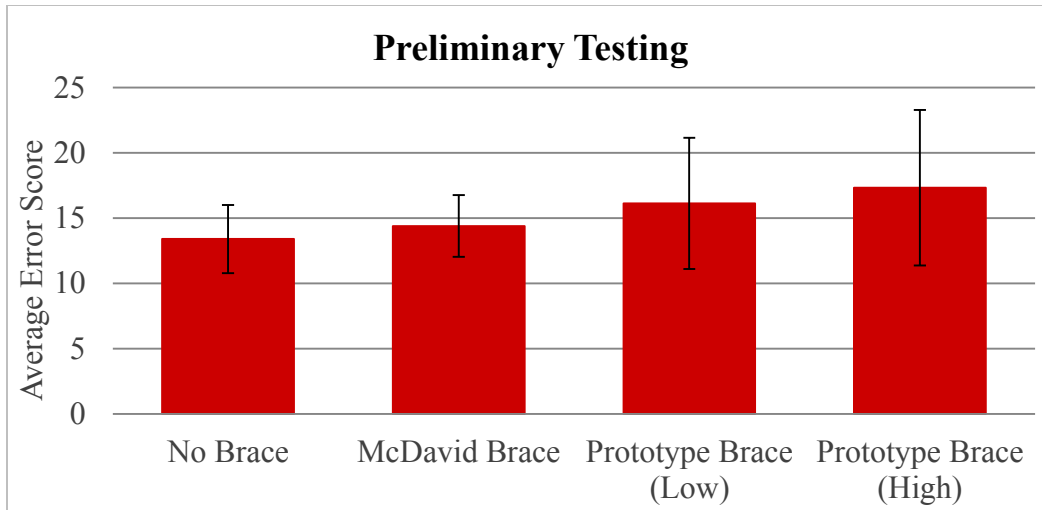

Figure 27: Preliminary Testing Data showing Error Score Averages for each Trial

The standard deviations for the trial data was calculated and used for the error bars. The first trial, without the foam pad, was analyzed but not compared to the other trials because without the foam pad as a control it was not comparable to the other trials. It can be seen from the data that the preliminary error score test shows an increasing error score trend from the no brace condition to the prototype brace condition at high support.

## 5.2. Force Plate Testing

In order to determine the effect of an ankle brace on ankle stability a test using a force plate was created. For this test the force plate was used to measure the subject's center of pressure during the five trials. For each of the trials the goal for the subject was to balance on the force plate on their right foot, with their hands on their hips, and their eyes closed for one minute. Each of the five trials differed slightly in order to determine how different controls and braces impact the subject's center of pressure. In the first trial the subject stood just on the center of the force plate with no brace. For the second trial a foam pad was placed on top of the force plate to increase the balancing difficulty on the force place. The foam pad was also used to simulate an uneven surface similar to ones on fields during sports. The foam pad was then set as a control in the following trials. For the third trial the subject wore a store bought ankle brace while balancing. In the fourth trial the individual wore the adjustable ankle brace designed by the project team. For this trial the inserts and straps of the brace were removed so the brace could be tested at its lowest stability setting first. For the fifth trial the subject again wore the brace designed by the project team but in this trial the inserts and straps were added in order to test the brace at its max stability setting.

During the trials a program called AMTI- Net Force, the force plate program, records data pertaining to gait and balance. The program recorded data including: the subject's center of pressure in the x and y axis, as well as the forces applied to the force plate in the x, y, and z axis. Acquisition settings were set so the force plate would record data for 60 seconds and take 100 readings per second. The program has two major panels the first is shown in the upper left that displays the force data being recorded during the trial and the second is in the upper right and it displays the center of pressure (COP) data that is being recorded during the trial (Figure 28).

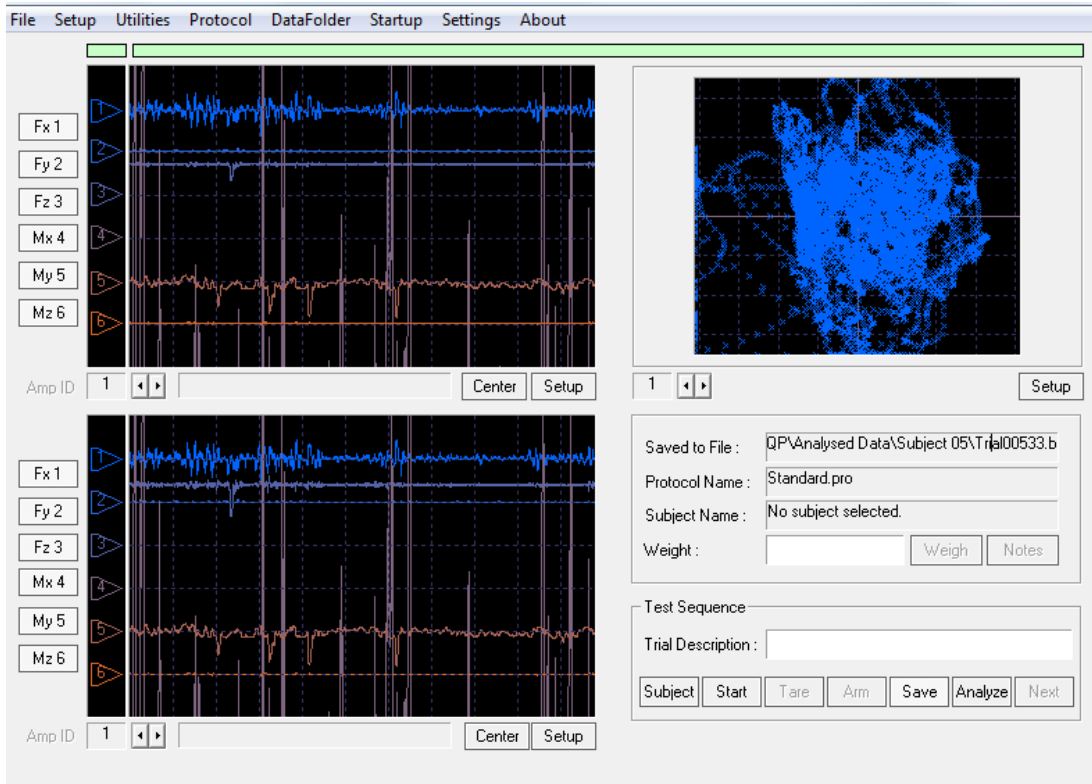

Figure 28: AMTI-Net Force Program Screenshot

Once the data was recorded using the AMTI program it was exported to BIOANALYSIS, a program that allows the user to analyze and graph the data recorded by the force plate (Figure 29). This program allows for force or center of pressure data to be plotted against either time or force plate coordinates. Although the graphing function of the program was useful, this program was mostly used for organizing the data received from the force plate. Once the data was organized into columns for each data type the data could then be exported to Excel where it could be further analyzed by the project team.

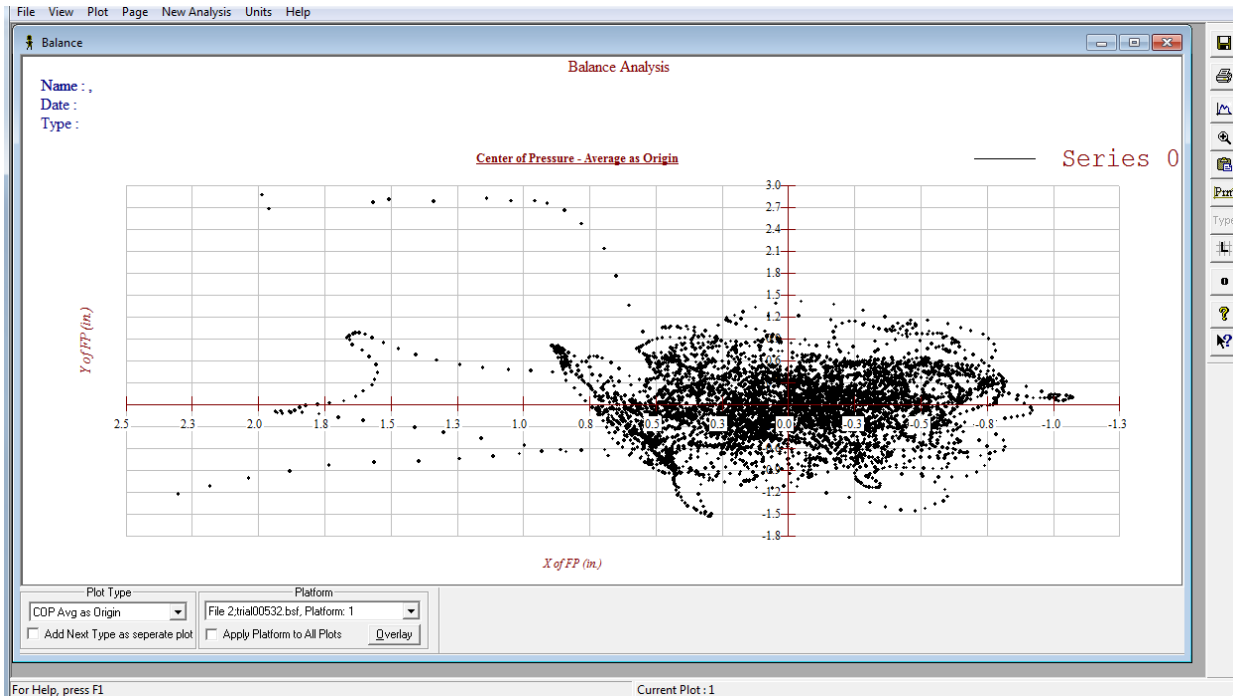

Figure 29: BIOANALYSIS Program Screenshot

↓ In Excel the force and COP data received was analyzed by trial and subject. For each subject the COP in x and y axis as well as the forces in the x and y axis were graphed for each of the five trials (Figure 30).

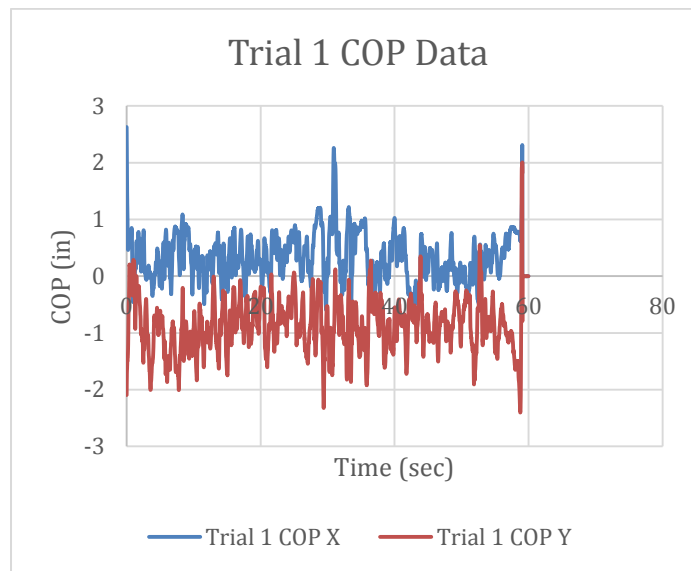

Figure 30: Example of COP Graph for Trial 1

These graphs were used as visual aids in order to display the change in COP or forces during each of the trials. Large changes in COP displays when the subject was unbalanced and large drops in forces display when the subject had fallen off the force plate. In order to quantitatively determine the

stability of the subject during each trial the excel function AVEDEV was used. This function returns the average of the absolute deviations of the data given from their mean data point. The equation used by the AVEDEV function in excel is  $\frac{1}{n} \sum |x - \bar{x}|$  this equation result gives the variability in the data set. The higher the value found the more variation there was in the data. In terms of COP greater variation means that the subject was less stable, comparing the average deviations from the mean enables quantitative comparison of stability between trials and subjects. For each subject the average deviations from the mean for the five data types: COP X, COP Y, Force X, Force Y, and Force Z were graphed for each trial.

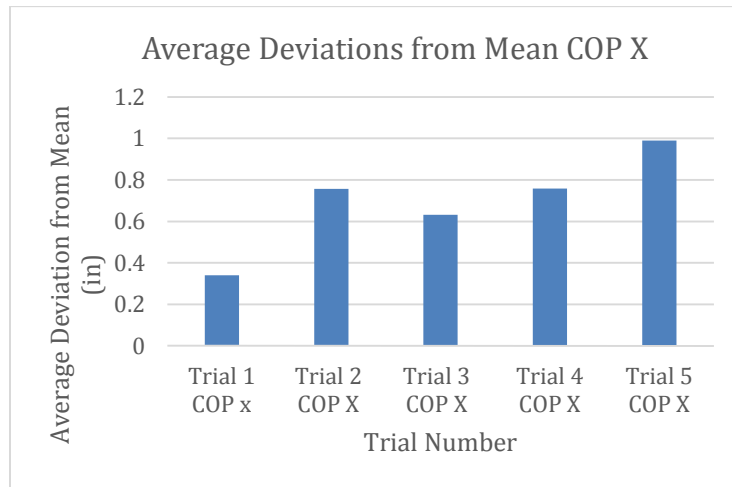

Figure 31: Example of a plot of average deviations for the mean for COP X for one subject for trials 1-5.

These graphs were used in order to visually display the stability measurements of the trials next to each other so that the subject's stability from trial to trial for that data could be quickly compared. Once the average deviations from the mean were recorded for all subjects, and trials the trial data could be compared to one another. To do this, the average of the average deviations from the mean were taken and then graphed for each of the five data types. These graphs display the average stability of all the subjects for each of the trials and thus allowed the project team to compare stability between trials and determine the effect the braces and foam pad had on stability.

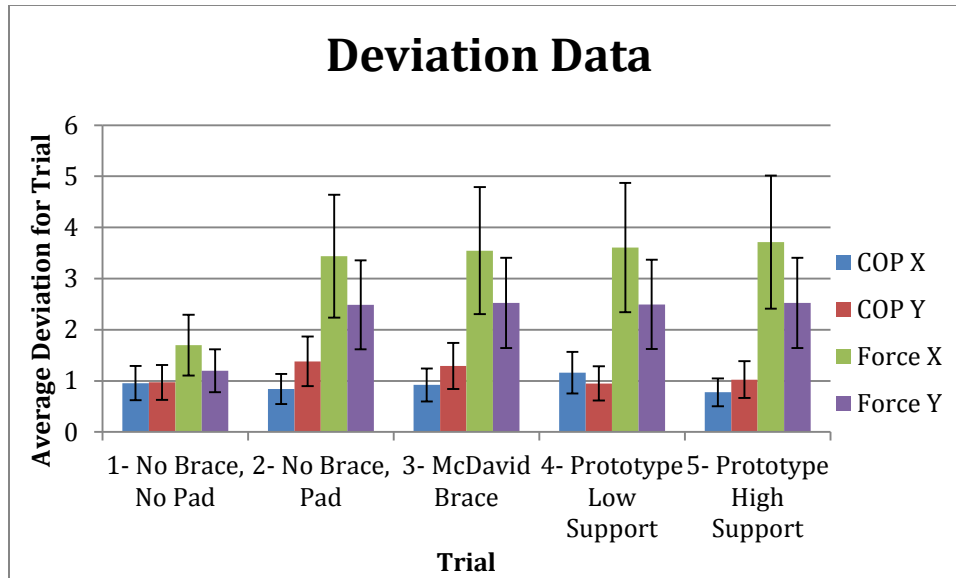

Figure 32: Average Deviations from the Mean for Different Data Types

It was found that Trial 1, without the foam pad had the lowest average deviation from the mean for all of the data types. Force in the x and y axis follow the same trend with average deviation constantly increasing from Trial 1 to Trial 5. The COP data on the other hand did not follow the same pattern. The deviation of COP in the x axis remained almost constant throughout the five trials while the deviation of COP in the y axis was highest in Trials 2 and 3 and lowest in Trials 1, 4, and 5 (Figure 32).

### 5.3. Detachable Sole Testing – Reaction Time

In order to show that the ankle brace we designed effectively increased the time between the initial step of a subject and the point of impact of the foot during an ankle inversion, a separate test was created. This test required an apparatus that was built to intentionally create a maximum of 20 degree inversion of the subject’s ankle, see Figure 33. This angle is a safe amount for the ankle to invert because it has been shown that the average ankle does not receive damage until an inversion angle of 30 degrees, as stated in previous sections. The test required the subject to take one step across the force plate with the apparatus attached to their foot. This test is initially done without an ankle brace and then repeated with the McDavid brace as well as the designed brace.



**Figure 33: Detachable Sole Apparatus**

During each trial AMTI-Net Force recorded the subject's force in the x, y, and z directions. However for this specific test, only the force data in the z direction was observed. The force in the z direction is equivalent to the subject's weight on the force plate.

Once the data was extracted from AMTI-Net, uploaded into the Bioanalysis software, and imported into excel the force data was analyzed by trial and subject. For each subject the Force in the z axis was graphed against time in order to display the time elapsed between the subject's initial step and the point where the majority of their body weight was on the force plate as a result of the apparatus, this can be seen in Figure 34. However as displayed in Figure 35, with a scale that exclusively shows the point of initial step to the point of inversion (the point where the majority of the subject's body weight is on the force plate), the activity between this brief moment in time is much more clear.

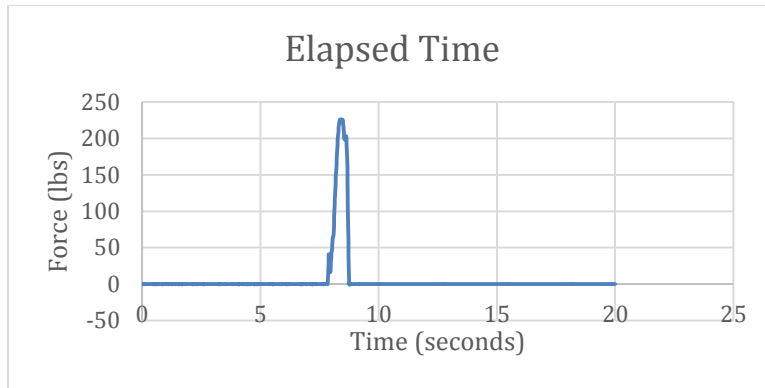

Figure 34: Example of graph created with data acquired from the Detachable Sole Test.

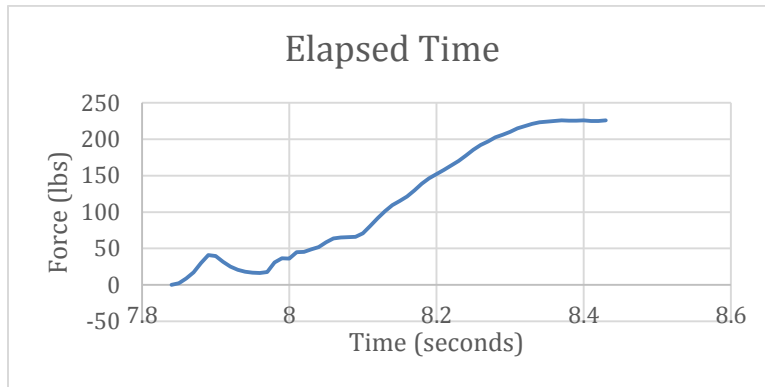

Figure 35: Detachable Sole: Time elapsed from initial touch to inversion.

These graphs served as our initial visual aid to calculate the time elapsed between the point of initial touch and inversion, which can be denoted here as the peak force on the graph. In order to accurately calculate the elapsed time between the two instances, we selected the last force value of a relatively consistent set of data points (minimum value) and subtracted the corresponding time value from the time value that corresponds to the maximum force value, or the peak force value.

	A	B	C		A	B	C
67	Time (seconds)	Force (lbs)		138	1.36	178.647	
68	0.66	0.986		139	1.37	178.812	
69	0.67	0.904		140	1.38	179.469	
70	0.68	0.986		141	1.39	180.865	
71	0.69	0.986		142	1.4	182.672	
72	0.7	0.986		143	1.41	184.643	
73	0.71	1.068		144	1.42	185.711	
74	0.72	0.986		145	1.43	186.04	
75	0.73	0.986		146	1.44	186.204	
76	0.74	0.986		147	1.45	185.957	
77	0.75	1.971		148	1.46	185.875	
78	0.76	3.696		149	1.47	181.276	
79	0.77	4.6		150	1.48	174.787	
80	0.78	5.75		151	1.49	173.062	
81	0.79	6.652		152	1.5	171.884	

Figure 36: Example of Value Selection for Elapsed Time Calculation

This process was done for each of the three different trials for each subject. Once this was complete, the averages of all the subjects in respect to their various trials were taken in order to create a comparison between no brace, the industry brace, and the groups designed brace (Figure 37).

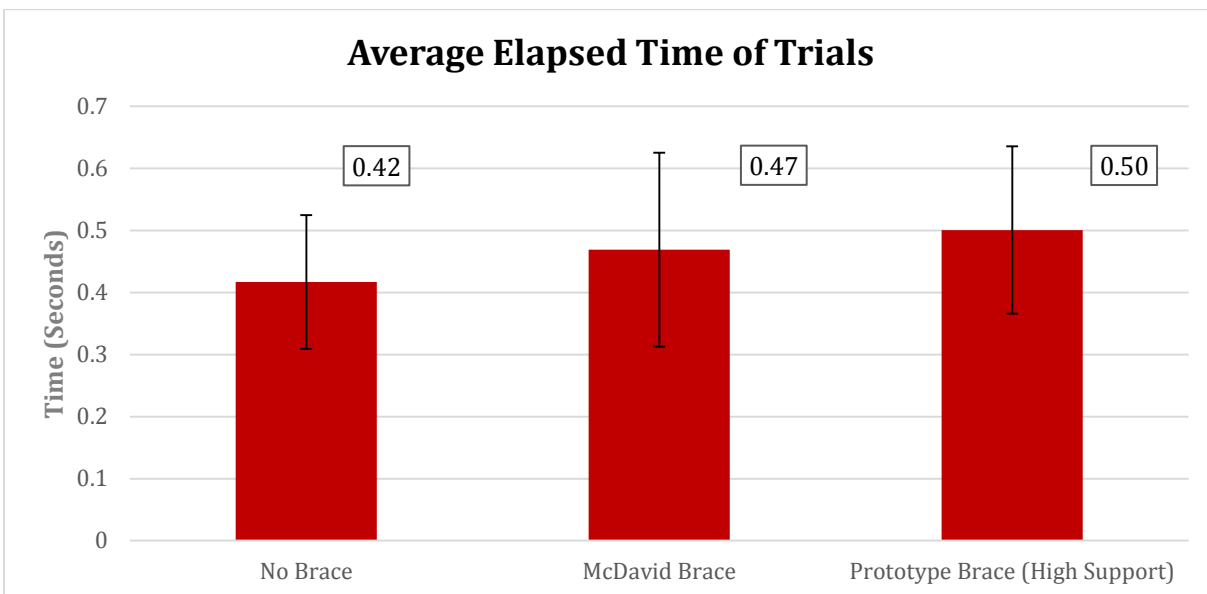

Figure 37: Average of all subjects elapsed time for each trial.



#### 5.4. Detachable Sole Testing – Linear Potentiometer

During the detachable sole test a linear potentiometer was used with an Arduino multi-controller, which determined the angle created whenever the potentiometer was moved while attached to the subject (Figure 38).

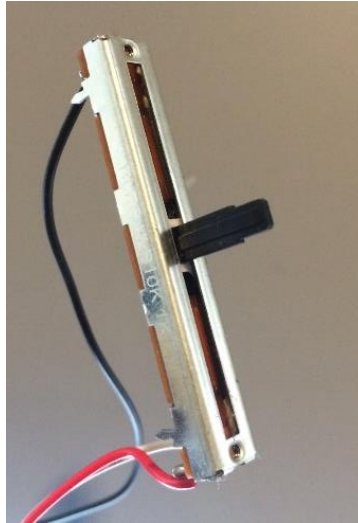

Figure 38: Linear Potentiometer

The potentiometer was attached to the subject's upper calf using a stretchable band and hooks. The potentiometer was then attached to the band and a retractable string was attached to the potentiometer as well as the bottom of the subject's shoe (Figure 39).



Figure 39: Linear Potentiometer attached to the calf of a test subject.

The detachable sole apparatus was then put on the subject's foot and the trials were completed. The detachable sole intentionally inverts the subject's ankle and the linear potentiometer

was used to determine how far the ankle inverted. As the subject took their initial step onto the force plate with the detachable sole and inverted their ankle, the linear potentiometer relayed to us the angle of inversion of the subject's ankle.

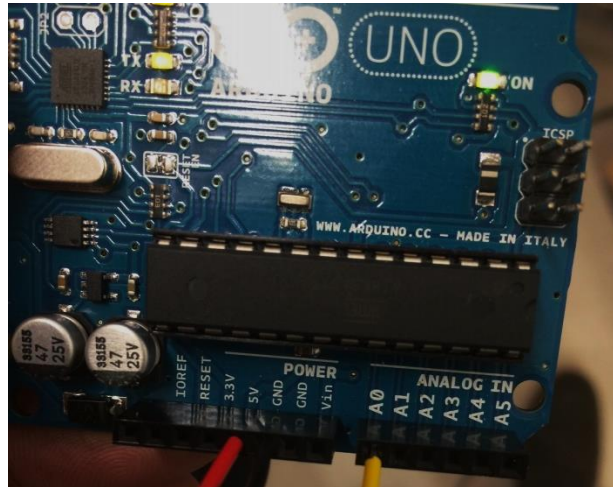

Figure 40: Arduino Uno used to record data from the linear potentiometer.

Using an Arduino (Figure 40) and software (Figure 41) the measurements recorded by the potentiometer were then displayed on the computer. These values were then inputted into Excel in order to be further analyzed.

```
mqp | Arduino 1.0.5-r2
File Edit Sketch Tools Help
mqp
int sensorValue = 0; // variable to store the value coming from the sensor
int angleValue = 0; // variable to store the angle value

void setup() {
  Serial.begin(9600); // initializes serial port with 9600 baud rate
}

void loop() {
  sensorValue = analogRead(sensorPin); // input from the sensor
  angleValue = (sensorValue-522)*45/407; // calibrated angle value from sensor input

  // prints sensor value and angle value
  Serial.print("Sensor Value: ");
  Serial.print(sensorValue);
  Serial.print(",\t");
  Serial.print("Angle Value: ");
  Serial.print(angleValue);
  Serial.println("");
}
```

Figure 41: Screenshot of Arduino software used to record the angle of the potentiometer.

Once the data was imported into excel it was sorted by trial. The average of each trial was then taken in order to analyze the trials compared to each other. The standard deviations of the trial data were used to create the graph error bars.

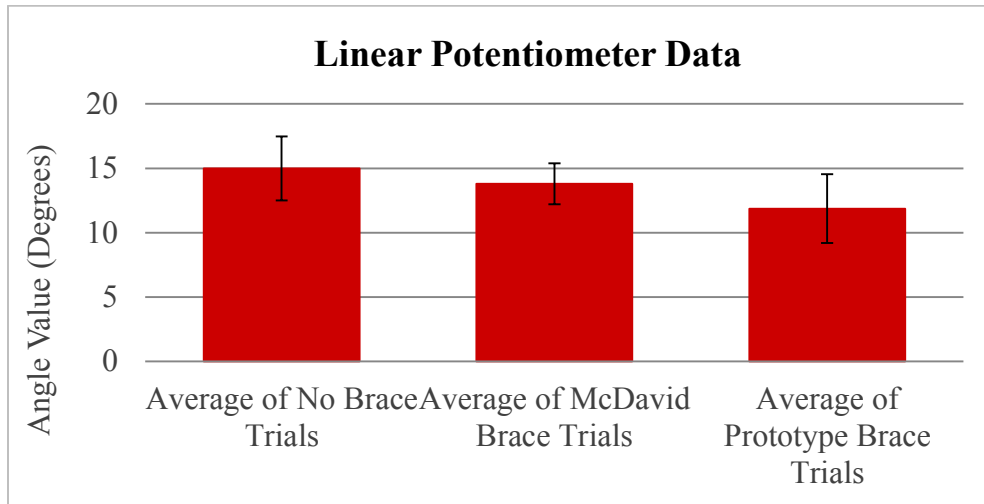

Figure 42: Data found from the linear potentiometer and detachable sole test.

The results from the linear potentiometer angle data showed a decreasing trend for the max inversion angle of the ankle from the No Brace Trials to the Average of the Prototype Brace Trials.

## 6. Discussion

After compiling the results from the experiments to validate the supportiveness of the designed brace vs. a top brace in the market, the results were thoroughly analyzed.

Before starting preliminary testing each participant was given a questionnaire in order to collect background information that could help us understand their individual results as well as set parameters depending on the individual needs of each participant. To protect the privacy of each subject, each individual was given a subject number which from there on out would be used for the rest of testing. The table below reiterates what testing was done and what trial numbers corresponded to each trial for the different types of testing.

*Table 4: Trial's corresponding to each test.*

<b>Trial #</b>	<b>Preliminary Testing</b>	<b>Force Plate Testing</b>	<b>Detachable Sole – Reaction Time Testing</b>	<b>Detachable Sole – Linear Potentiometer</b>
1	No Pad, No Brace	No Pad, No Brace	No Brace	No Brace
2	Pad, No Brace	Pad, No Brace	McDavid Brace	McDavid Brace
3	Pad, McDavid Brace	Pad, McDavid Brace	Prototype High Support	Prototype High Support
4	Pad, Prototype Low Support	Pad, Prototype Low Support		
5	Pad, Prototype High Support	Pad, Prototype High Support		

\*blank spaces indicate there was no trial with that number for the test listed above

### 6.1. Preliminary Testing

The preliminary testing resulted in error scores which correlate to the stability of the subject's ankle during the trials. As stated previously in the results section, it was found that there was an increasing trend from the No Brace to the Prototype Brace (High) condition (Figure 43).

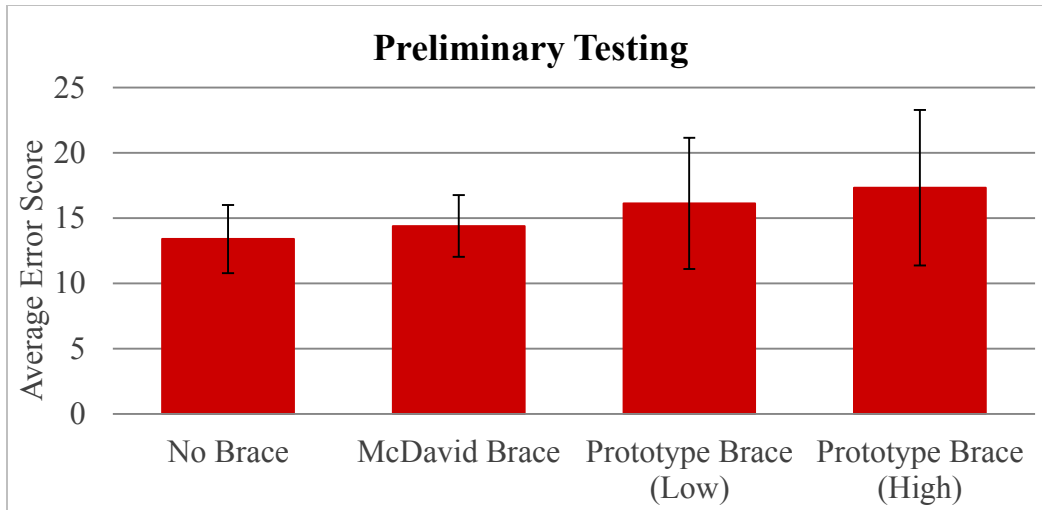

Figure 43: Preliminary testing data showing error score averages for each trial.

Although the error scores were used to determine balance this trend is counterintuitive, the increased error scores shows an increase in ankle stability not a decrease. This is because as the stability of the ankle increases due to a higher level of support (for example a stiffer or more supportive brace) the subject's ability move and balance decreases. This decrease causing their error score value to increase but it shows that their ankle is receiving more support from the brace.

Table 5: Preliminary testing data showing error score average values for each trial.

	No Brace	McDavid Brace	Prototype Brace Low Support	Prototype Brace High Support
<b>Average Error Score</b>	13.4	14.4	16.13	17.3

Based on this information the data received from this test showed that the prototype brace at both high and low support conditions provided more support than the McDavid Brace and the No Brace conditions.

## 6.2. Force Plate Testing

The force in the z-axis represents the weight on the force plate. This weight deviates if the subject steps off the force plate during the trial. If the subject placed their second foot down there is a slight change in weight and if the subject steps off or falls off the force plate there is a significant change in weight. Therefore the more the subject steps off the force plate the higher the average deviation would be for that trial. The data found for shows that Trial 5, the Prototype brace at max support, had the lowest deviation for this data compared to the other trials with the foam pad (Trial 1 is excluded because the foam pad is not being used).

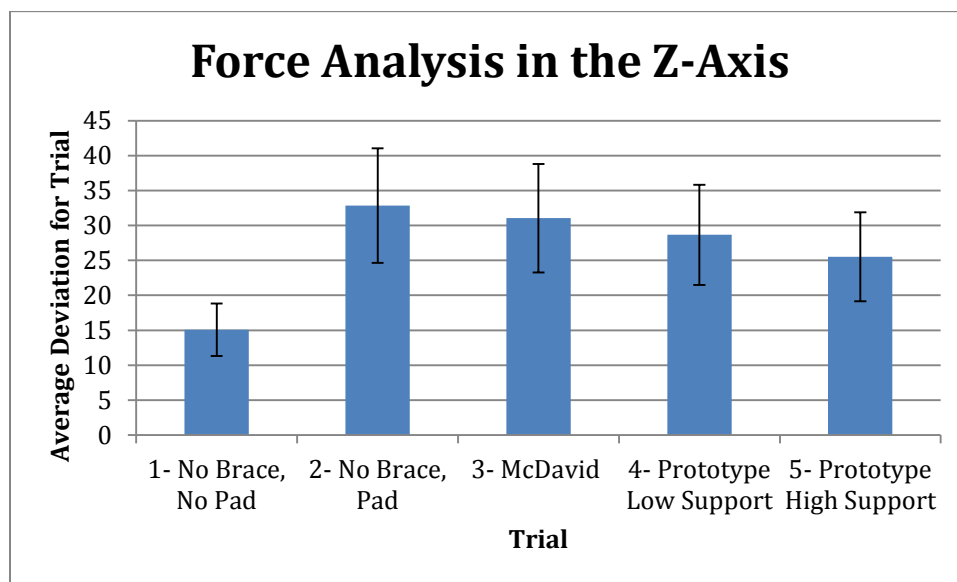

Figure 44: Force in Z-axis Analysis of average deviation from the mean.

Trial 5, the prototype brace at max support, showed the lowest deviation out of all the trials. This shows that the brace at maximum stability helped to reduce the number of times the subject fell off the force plate (Figure 44). This could be because although the prototype brace reduced the balance of the subject, as stated in the previous section, the subject normally only stepped their other foot down for support instead of completely stepping off the force plate. This is due to the brace reducing the subject's side to side ankle movement due to increased support which causes them to quickly step down instead of moving side to side and eventually stepping off the plate. This demonstrates that the prototype brace had an impact on increasing the subject's ankle stability. It can also be seen that all three trials that used an ankle brace (Trials 3-5) had greater stability compared to

Trial 2 which was the No Brace condition on the foam pad. This shows that ankle supports in general can help to increase subject stability.

Although the data for force in the z-axis had a distinguishable trend the rest of the data did not demonstrate trends that correlated with the background research done on ankle supports and ankle stability. The force in the x and y axis remained relatively constant throughout the foam pad trials (Trials 2 through 5) while the COP in the x and y varied from trial to trail with no significant trends (Figure 45).

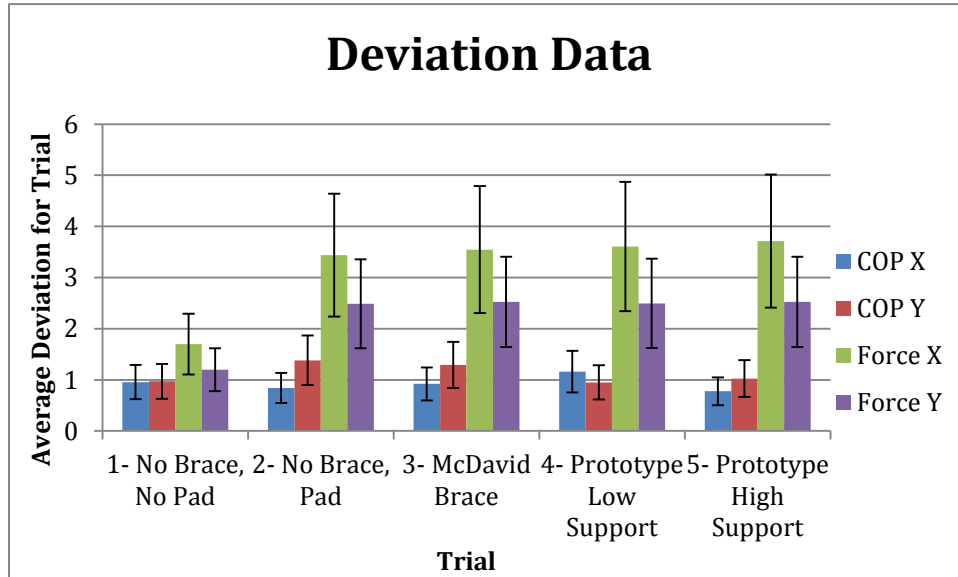

Figure 45: Average deviations from the mean for different data types.

### 6.3. Detachable Sole Testing – Reaction Time

The detachable sole test was the last test conducted on our test subjects. This tested provided essential data that would ultimately determine whether or not our brace has the ability to provide as much support as industry braces by increasing the time between the initial touchdown of the foot until the point of inversion.

After analyzing the data within excel, we were able to conclude that on average, our brace effectively provides more time between the initial touchdown of the foot and the point of inversion. For example in Figure 46, it can clearly be seen that subject six's elapsed time between the two instances described increased ever so slightly.

Time Values	No Brace	Store Brace	Our Brace
Subject Number	Trial 1	Trial 2	Trial 3
1	0.45	0.48	0.46
2	X	X	X
3	0.47	0.45	0.71
4	X	X	X
5	X	X	X
6	0.32	0.37	0.38
7	0.55	0.59	0.54
8	X	X	X

Figure 46: Example of Time Values per Trial

The increase in time can be attributed to the fact that with an increase in restriction of the ankle region, it takes longer for the ankle to reach its maximum point of inversion in a given situation. This increase in time, regardless of how small, shows that our designed brace provides more stability than the McDavid brace. With more stability, an athlete is less likely to sustain an ankle injury. By subtracting the average time of Trial 2 (McDavid Brace) from Trial 3 (Project Team Brace), we were able to determine how much more time the designed brace provided between the instances described, and ultimately how much more stability it provided. The data shows that on average, the designed brace, fully equipped with inserts, creates approximately 0.0314 second greater gap in time between the initial touchdown of a subject to the actual inversion of the ankle Figure 47. To find all the data related to the average elapsed time for each trial of each subject, including percent increase see Appendix M.

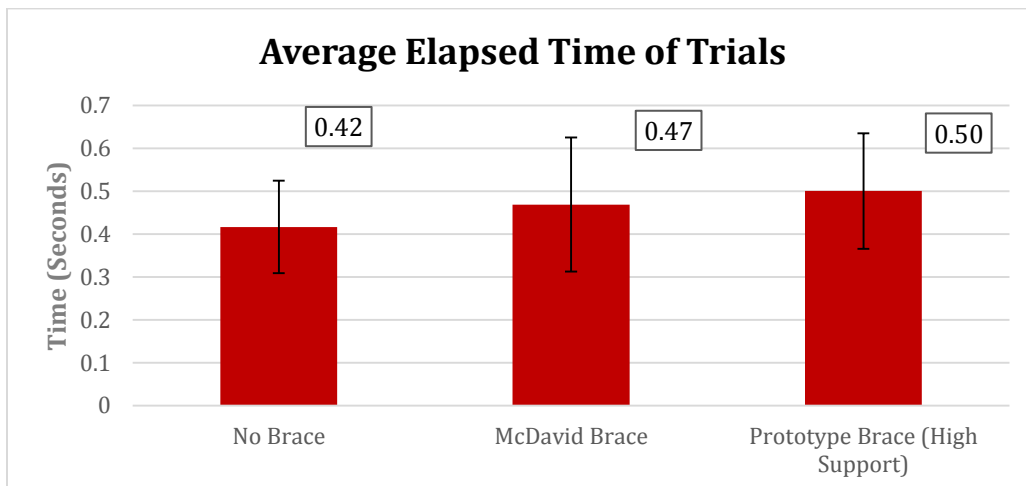

Figure 47: Average of All Subject Elapsed Time of Each Trial



#### 6.4. Detachable Sole Testing – Linear Potentiometer

As stated previously in section 5.3.2, the results from the linear potentiometer angle data showed a decreasing trend for the max inversion angle of the ankle from the No Brace Trials to the Average of the Prototype Brace Trials. This decreasing trend shows that the prototype brace at max support reduced the angle of inversion of the ankle more than the McDavid Brace and the No Brace condition (Figure 48).

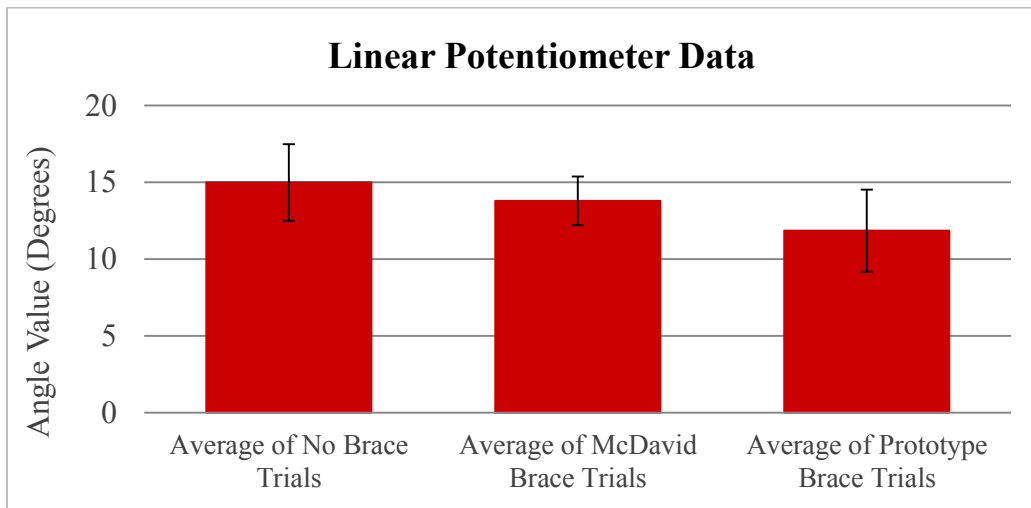

Figure 48: Data found from the linear potentiometer and detachable sole test.

This data supports that the prototype brace at max support provides the greatest stability to the subject's ankle because it shows that the brace kept the ankle from inverting as far as the other two trials. The results also show that both braced conditions did have an impact on reducing the amount of inversion compared to the No Brace condition. This shows that ankle supports in general have an impact on increasing the stability of the user's ankle.

#### 6.5. Tilt Testing

This test was initially supposed to be the second stage of testing. It was going to measure the angle of rotation of the ankle while it was being inverted using a trap door apparatus. This apparatus simulated inverting the ankle to different angles using a trap door and solenoids to control the angle of inversion of the door. The linear potentiometer used in the Detachable Sole Testing was to be attached to the subject's calf and would record the angle of inversion the same way it did for the Detachable Sole Test. Our group did design and build the apparatus but unfortunately it was not operational in time for the allotted testing period. Further review of this apparatus can be found in Chapter 7: Final Design and Validation.

## 6.6. Statistical Analysis

A one-way analysis of variance (ANOVA) was used to determine whether there were any significant differences between the means of three or more independent or unrelated groups. These groups included testing without a brace, testing with the McDavid brace currently on the market, and testing with the project team's prototype in high support and low support. Only preliminary testing, detachable sole reaction time testing, and detachable sole linear potentiometer testing were analyzed. Testing conducted on center or pressure and forces in the x, y, and z were left out of the ANOVA test because the data did not show any sort of trend.

A p-value of 0.05 was selected as a standard for biomedical products. If testing had a p-value less than 0.05, the null hypothesis was rejected which means testing showed significant differences in the means of the testing groups. If the p-value is greater than 0.1, there was a weak to no presumption about the null hypothesis and anything in between a p-value of 0.05 and 0.1 showed a strong to very strong presumption against the null hypothesis. The results of the ANOVA are seen in Table 5 below.

*Table 6: Results from ANOVA Test*

<b>Test</b>	<b>P-Value</b>
<b>Preliminary Testing</b>	7.47E-13
<b>Detachable Sole Reaction Time</b>	0.230
<b>Detachable Sole Linear Potentiometer</b>	0.015

As can be seen, both preliminary testing and detachable sole linear potentiometer testing rejected the null hypothesis and showed a significant difference between the means of their testing groups. On the other hand, the detachable sole reaction time testing had little to no presumption about the null hypothesis. This may have been due to the fact that the reaction time numbers recorded are so small; however, a typical ankle sprain will happen in less than one second and while this is hard to visualize, the numbers recorded are as accurate as possible. Although the detachable sole reaction time had no presumption against the null hypothesis, the project team still believes there is a correlation with the rest of the data recorded. Data showed an increasing trend going from the no brace to braced conditions which supports the project team's conclusion that braces have a stabilizing and supportive effect.

## **6.7. Project Considerations and Impacts**

In any design project it is important to take into account many factors such as manufacturability, economics, ethical, and social issues.

### **6.7.1. Manufacturability**

Manufacturability is a very important aspect to any design project. If a design is not manufacturable then it is useless. Even if a design can be manufactured but the process is long and difficult than the cost of manufacturing will be too high to consider production. Keeping this in mind the ankle brace we designed will be relatively easy to manufacture. The materials chosen were all materials that are easily accessible especially in the ankle brace market. The stitching of the Velcro and neoprene can both be done with a sewing machine. The biggest obstacle we faced when manufacturing the brace was the cutting of the plastic inserts. The plastic we used cannot be laser cut so we needed to use a hand saw. Though this was not the easiest task for our team it can be done faster and more precise with CNC machinery.

### **6.7.2. Economics**

For each stage of ankle rehabilitation there are different kinds of ankle support. Athletes constantly have to buy new items to help them get back into the game. The best way to minimize rehabilitation costs is to introduce a new device that has been tested and proven to support multiple stages of rehabilitation.

As evidenced in the Background section of this report, there is a lot of competition in the ankle brace market. Each company has their own style of brace and their own target rehabilitation stage. By combining the best qualities of the market's most popular braces into one brace we can draw clients from all rehabilitative stages to try our brace leading them to a less expensive, higher quality rehabilitation.

### **6.7.3. Ethics**

Within the scope of the research there were no real ethical concerns to be addressed. The goal of this project was to design and develop an ankle brace to be used for multiple stages of ankle rehabilitation. If anything, the only ethical impact in relation to this project would be to ensure this brace does not harm any athlete.

### **6.7.4. Social**

This new brace should be accepted into society. This design is an innovative one constructed from the popular features of current braces in the market and, therefore, should come naturally into

circulation. This brace should be able to be easily marketed as the new gold standard for ankle braces and ankle rehabilitation.

## 7. Final Design and Validation

This chapter will discuss the process in creating and conducting the final design, reviewing the detailed specifications in our design and testing methods, and our reason for choosing each design decision. Out of the four preliminary designs, the chosen final design was preliminary design #5, the adjustable ankle brace design (Figure 49). This design was constructed into a prototype consisting of removable straps, removable inserts, and a compression sleeve.

### 7.1. The Final Design: The Adjustable Ankle Brace

The final design was constructed using a McDavid level 3 195™ ankle brace with straps. This brace was stripped of all straps leaving solely a single layer of nylon fabric, which was used as the

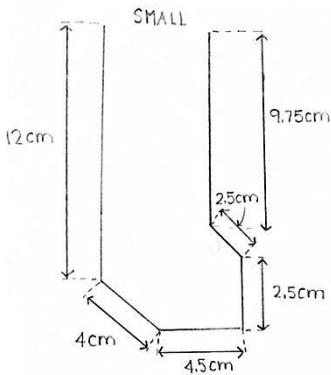
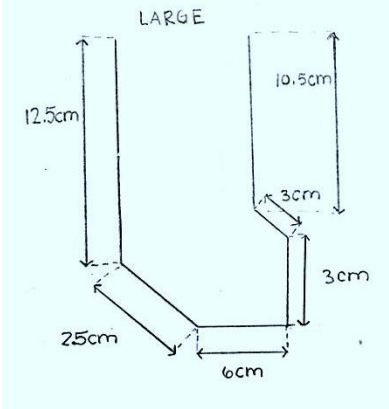
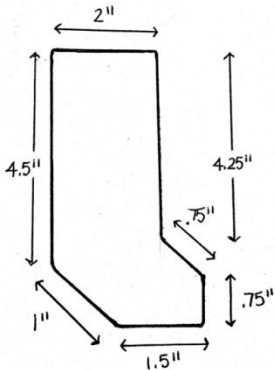
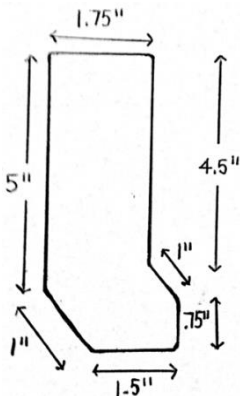

Figure 49: Final Design of Ankle Brace

base layer of the adjustable ankle brace. A layer of single-sided neoprene, 3 mm thick, was then sewn to the bottom of the brace. The neoprene layer allowed for greater friction between the brace and the shoe, minimizing movement and creating better stability. Using nylon thread, two neoprene pockets were sewn onto both sides of the brace where the ankle joint and the brace would meet while a person's foot is completely in the brace. Removable inserts, which are placed into the previously discussed neoprene pockets, were made using pieces of polycarbonate (Levan) and were cut into L-shapes using a hacksaw and a sander. An ACE™ ankle support, which was smaller than the McDavid brace, was sewn onto the inside of the brace creating compression for the user. A top strap was created using a piece of Velstretch, which was sewn around the top opening of the brace. The support straps, which are attached by the laces, were used from the McDavid brace. Three small holes were cut into the non-Velcro end of each strap allowing the laces to go through them. To prevent fringing of the fabric a lighter was carefully used to melt the edges around each hole creating a smoother surface. Due to the variety of subjects participating in the team's study, two

ankle braces were built, a small and a large. Specifications for each brace design can be found in the table below:

Table 7: Materials for Adjustable Ankle Brace Design

	SMALL	LARGE
<b>Base</b> (Single layer of lightweight nylon and vinyl fabric shell)	medium McDavid ankle brace	extra large McDavid ankle brace
<b>Pockets</b> (neoprene)	dimension 	dimensions: 
<b>Side Straps</b> (nylon)	straps from medium McDavid ankle brace	straps from extra-large McDavid ankle brace
<b>Inserts</b> (polycarbonate)	dimensions: 	dimensions: 

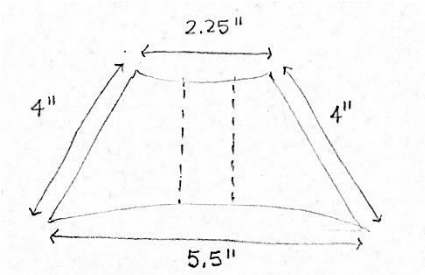
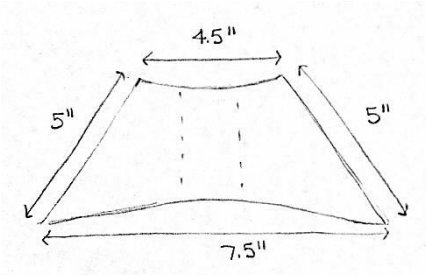
<b>Top Strap</b> (velstretch)	dimensions: 15 ½ inches x 2 inches	dimensions: 16 ½ inches x 2 inches
<b>Bottom Grip</b> (neoprene)	dimensions: 	dimensions: 
<b>Compression Sleeve</b> (elastic/neoprene blend)	ACE™ ankle support	large ACE™ ankle support

## 7.2. Testing Methods

Three tests were constructed to test our prototype against with and without a brace; the

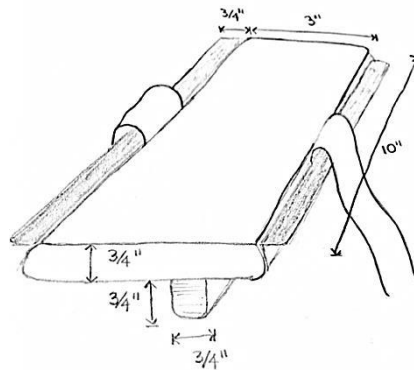

Figure 50: Dimensions of the Detachable Sole Test

detachable sole test, the force plate test and a tilt test. The detachable sole was built using plywood, metal, screws, Velcro straps, and grip tape (Figure 50).

One section of plywood was cut into 10 in. x 3 in. ¾ in. dimensions to be used as the platform of the apparatus, while another piece was cut into 10 in. x ¾ x in. ¾ in. to be used as the fulcrum. The fulcrum was then screwed into the wooden platform using three screws. Two 9-inch long metal edges were screwed into the side of the platform giving a fair amount of space for the Velcro straps to slide through. Two Velcro straps (20 inches and 30 inches long) were inserted with

the hook, better known as the rough side, facing inward and the screws were tightened to secure the straps. Finally, grip tape was applied to the top of the platform to prevent slipping between the foot and the apparatus, while also keeping the apparatus in unison with the foot.

Testing the detachable sole apparatus required a force plate, NetForce Software, BioAnalysis Software, a potentiometer, and four platforms of similar dimensions to the force plate. To set up the test, the force plate was placed on the floor with two stacked platforms side by side in front of the plate allowing approximately an inch slit for the fulcrum to fit snug. This allowed test subjects to keep their feet level when beginning the test, in addition to, stepping down onto the force plate, enabling a more accurate test. The test would begin by placing the apparatus in the slit and asking the subject to step onto the detachable sole with their right foot, in which a tester would then strap on the detachable sole (Figure 51). The shortest strap would cross over the foot and enter the fastener, while the longer strap would cross over the front of the foot, loop around behind the foot, and then crossover the front of the foot again and enter the fastener. From this position, both straps would be tightened to fit the subject's foot, cross over the front of foot and be fastened.

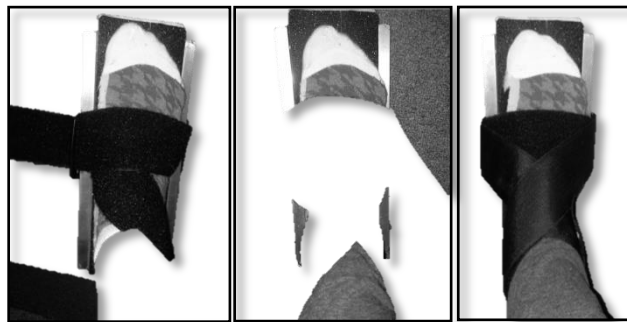

Figure 50: Straps on the Detachable Sole

The detachable sole would be fastened to the foot in this fashion with a brace and without. Once strapped in, the potentiometer would be hooked up, and the force plate would be zeroed. The subject would be told to step down onto the force plate with their right foot, holding the detachable sole, and step off the force plate with their left. This test was performed twice for each scenario.

The second test constructed to test our prototype was the force plate test. This test would measure the subject's ankle stability without a brace, with the McDavid brace and with our brace, where a force plate, a foam pad, NetForce System and BioAnalysis Software is needed. Before beginning the test, subjects were asked to complete preliminary testing. The subject would balance on their right foot on the force plate with no pad and no brace for 60 seconds. They must stay in a certain position where they keep their hands on their hips, eyes closed, and left foot off the ground. For each time the subject did not remain in this position, strikes would be tallied up. If the subject received over 30 tallies in the 60 seconds of testing this subject will be eliminated. If the subject got



lower than 30, they passed the preliminary testing, and could proceed with testing. The subjects would proceed testing by balancing on a foam pad on the force plate without a brace, with a McDavid brace (grade level III) and with our prototype at high support.

The third and final test was the tilt test, which was intended to measure the reaction time of the ankle without a brace, with a McDavid brace, and with our prototype. To build this apparatus, multiple boards of plywood, nails, a hammer, a hinge, a saw, a plastic sheet, solenoids and superglue were needed. Plywood, 3/4 of an inch thick, was cut up into appropriate dimensions seen in Figure 52. Before the boards were nailed together, one sideboard had 6 1/2-inch diameter holes drilled into the wood for the solenoid locks to be placed. These solenoids would serve as a stopper for the trap door at the 5°, 10°, 15°, and 20° mark. All pieces of plywood were nailed together, with exception to the trap door that was attached with a hinge and screws. Galvanized steel wire was looped through the locks to pull the solenoids out from under the trap door and a strip of plastic was super glued to the edge of the wooden trap door, allowing the solenoid to pull out with greater ease. Lastly, grip tape was applied to the top of the trap door to prevent subjects from slipping when the door dropped.

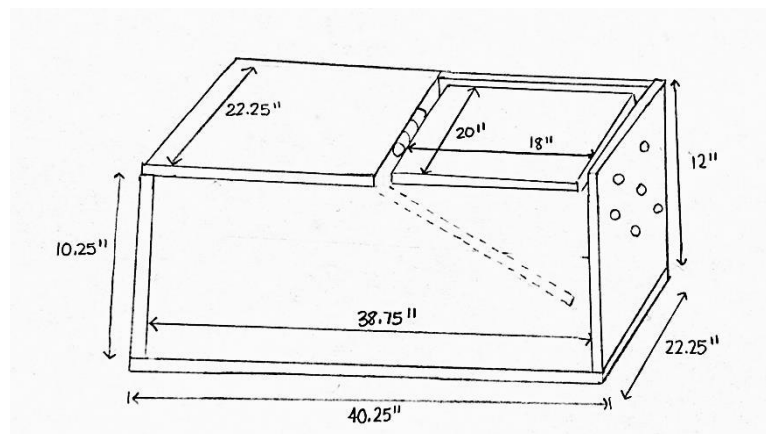

Figure 51: Dimensions for the Tilt Test

To perform the tilt test, subjects would be told to step on top of the apparatus, right foot on the trap door. A tester would hook up the potentiometer onto the subject's right leg, which would record the subject's degree of ankle inversion during the test. When ready, a tester would gradually drop the door starting at 5 degrees at an increasing increment of 5 degrees all the way to 20. A subject would repeat this procedure twice for each scenario including, no brace, with a McDavid brace, and with our prototype.

Given the time and resources provided, the project team was able to execute both the detachable sole test and the force plate test (Appendix K). The tilt test, on the other hand, could not be executed on subjects due to the trap door being extremely inconsistent. The large amount of

weight that was exerted on the door increased friction between the plastic layer and the metal solenoids preventing the solenoids from pulling out smoothly and consistently. The project team discarded the test because it would not be able gather valid or consistent data.

## 8. Conclusions and Recommendations

### 8.1. Conclusions

1. The final design is a plausible solution to the problem presented in our revised client statement.

The final design met all the requirements of the client statement and is the first brace of its kind. The multi-stage design is more beneficial to prospective buyers because the cost of the one brace will be less than the cost of purchasing multiple rehabilitative items.

2. Testing showed that the brace increased one's stability through steadying their center of pressure

We had 20 participants in our study who did five force plate trials which included: bare ankle on force plate, bare ankle on foam pad, McDavid brace on foam pad, our brace LIGHT on foam pad, and our brace FULL on foam pad. Through these trials we compared the center of pressure results on the x and y axis to identify one's stability. Our brace when in FULL support had minimal fluctuation with center of pressure results supporting our theory of the designed brace providing the maximum support for the ankle joint.

3. Testing showed that the brace prevents one's ankle from any rolling motion.

From the obtained data, it was established that the final design limited the inversion and eversion angles of the ankle. The brace provided more support to the subject's ankle for the overall angle.

### 8.2. Recommendations

#### 8.2.1. Testing Recommendations

There are several recommendations for the design and testing of the adjustable ankle brace created over the course of this project. First of all we recommend that the biomechanical video analysis be conducted to help quantify the angle of rotation of one's foot throughout the trials. This would allow the analysis of ankle rotation during each stage of testing since the current methods only use a potentiometer to receive this information during the final stage of testing. These numbers would provide more verification that the design reduces the angle that the ankle rotates that could lead to eversion/inversion injuries. The video could also provide how the designed brace is working. For example if it appears that more support could be provided around the joint of the ankle then the team could design the brace so the plastic inserts extend slightly lower.

Another problem we faced was the matter of testing the ankle while it is participating in the movements that cause injury. Although our tests provide stability data on a flat surface, most injuries obtained are due to forces that accompany a flat surface. For further analysis we would advise to test during these movements to see the stability of the joint when it is put to work in competitions.

Lastly, our third testing apparatus, the tilt test, was unfortunately not able to be used for testing. We would advise groups beyond us to use our research and basic design to recreate the apparatus. One of our redesign recommendations would be to adjust the type of solenoids used for the different angles that the box would drop. The current design used solenoids that need to be switched at a specific angle for them to release where as in the future we would recommend the solenoids be switched at an easier angle, preferably one that is directly away from the apparatus. Also the design specified that there were two solenoids at each angle increment. For future testing of this apparatus we would advise groups to either connect the two solenoids to be switched at the same time or to only use one solenoid per angle increment. This would increase the success rate of the switches and provide more accurate results. For this apparatus we would also recommend use of biomechanical video analysis to view the angle of inversion the ankle exhibits vs. the angle that the apparatus is designed to express.

### **8.2.2. Design Recommendations**

The design was obtained using the research and designs of the top leading brands in the ankle brace market as well as the research of our team and we are very proud of the result. We did however, discover a few aspects of our design that could be enhanced to make the brace that much more appealing and supportive. The first enhancement would be for the visual appeal of the brace. Our group used a white compression sock for the innermost layer of the brace while we would recommend keeping the entire brace to one color, black. This color is neutral and appears to be the most appealing in the market.

In order to provide more stages of support our team would recommend including another insert option. The current pockets only have one insert for them where for even more flexibility there could be another insert made of a different material that would provide slightly more flexibility than the plastic inserts but provide more support than just the detachable straps. We would recommend a thin memory foam material to provide this level of support.

Another improvement that could be made in the brace department was the type of plastic used. We chose the polycarbonate (Levan) plastic due to its level of flexibility and its thickness. Unfortunately we later found out that this plastic cannot be cut using a laser cutter. We would advise groups extending this project to look to use a plastic that has similar qualities but that can be cut

using a laser cutter. This will be the easiest and quickest way to cut plastic and surely expedite manufacturing.

Our final recommendation would be to improve upon the consistency when testing. For example we would have a member of our project group put the brace on each participant the next time around to make sure the brace was applied properly and that each stage of the brace was properly intact. This would ensure that the data for each test would be as accurate as possible.

## References

- Administrator (2006) Ankle Anatomy. Orthogate. Retrieved September 20, 2013, from <http://www.orthogate.org/patient-education/ankle/ankle-anatomy.html>
- Ambegaonkar, Jatin P., Nelson Cortes, and Shruti J. Ambegaonkar. "Effects of Ankle Bracing on Athletic Performance." *Lower Extremity Review Magazine*. N.p., June 2012. Web. 14 Sept. 2013.
- "Ankle brace." *Pharmacy Times* Feb.-Mar. 2009: 38. Academic OneFile. Web. 7 Sept. 2013. Document URL <http://go.galegroup.com/ps/i.do?id=GA>
- "Ankle sprains." *World of Sports Science*. Ed. K. Lee Lerner and Brenda Wilmoth Lerner. Detroit: Gale, 2007. Science In Context. Web. 11 Sept. 2013.
- Ankle Taping vs. Ankle Braces. Retrieved from pre-wrap.com website: <http://pre-wrap.com/blog/2009/07/ankle-taping-vs-ankle-braces/>
- Barry, Mark E., and Kathleen Kearney. "Emergency: Ankle Sprains." *The American Journal of Nursing* 101.10 (2001): 40-42. JSTOR. Web. 22 Sept. 2013.
- Castro, E.G. (2002). US Patent 6,443, 919 B1. Washington, DC: U.S.
- Chan, K.-M., Chan, L.-K., Fong, D. T.-P., Hong, Y., & Yung, P. S.-H. (2007). A Systematic Review on Ankle Injury and Ankle Sprain in Sports. Retrieved from go.galegroup.com website:[http://go.galegroup.com/ps/i.do?action=interpret&id=GALE%7CA200844641&v=2.1&u=mclin\\_c\\_worpoly&it=r&p=AONE&sw=w&authCount=1](http://go.galegroup.com/ps/i.do?action=interpret&id=GALE%7CA200844641&v=2.1&u=mclin_c_worpoly&it=r&p=AONE&sw=w&authCount=1)
- Cheung, J. T., Zhang, M., Leung, A. K., & Fan, Y. (2004). Three-dimensional finite element analysis of the foot during standing – a material sensitive study. *Journal of Biomechanics*, 38, 1045- 1054.
- Corazza, F., O'Connor, J.J., Leardini, A., and Castelli, V.P. (2003). Ligament fibre recruitment and forces for the anterior drawer test at the human ankle joint. *Journal of Biomechanics*, 36(3), 363-372.
- Dawe EJC, Davis J (2011) (vi) Anatomy and biomechanics of the foot and ankle. *Orthopaedic and Trama*, 10(4), 279-286.
- Denyer, Joanna R., Naomi L.A. Hewitt, and Andrew C.S. Mitchell. "Foot structure and muscle reaction time to a simulated ankle sprain." *Journal of Athletic Training* 48.3 (2013): 326+. Academic OneFile. Web. 11 Sept. 2013.
- Detty, M. K. (1994). US Patent 5,472,414. Washington, DC: U.S.
- Duback, J. E., Floyd, C. B., & Friday, M.G. (1999). US Patent 5,868,693. Washington, DC: U.S.
- Dubin JC, Comeau D, McClelland RI, Dubin RA, Ferrel E (2011) Lateral and syndesmotoc ankle sprain injuries: a narrative literature review. *Journal of Chiropractic Medicine*, 10(3), 204–219

Dym, C., & Little, P. (2009). *Engineering design: A project-based introduction*. (3rd ed.). Hoboken, NJ: John Wiley & Sons, Inc.

Elis, Eric, Christina Demming, Guido Kollmeier, Lothar Thorweston, Klaus Volker, and Dieter Rosenbaum. "Comprehensive Testing of 10 Different Ankle Braces Evaluation of Passive and Rapidly Induced Stability in Subjects with Chronic Ankle Instability." *Clinical Biomechanics* 17.7 (2002): 526-35. Science Direct. Web. 22 Sept. 2013.

Folkowski, Paul. "Considerations in the Use of Ankle Braces." *Ahtletic Therapy Today: The Professional Journal for Athletic Trainers and Therapists* 3.4 (July 1998): 37-41. Print.

Gardner, Jacob K. "Ankle Bracing: Exploring Effects on Proximal Joints." *Lower Extremity Review Magazine*. N.p., Oct. 2012. Web. 14 Sept. 2013.

Giblin, C. (2013). *Sports Injuries: The 8 Most Common Injuries*.

Golano P, Vega J, de Leeuw PAJ, Malagelada F, Manzanares MC, Götzens V, van Dijk CN (2010) Anatomy of the ankle ligaments: a pictorial essay. *Knee Surg Sports Traumatol Arthrosc* 18. doi: 10.1007/s00167-010-1100-x.

"Goniometer." Wikipedia. Wikimedia Foundation, 22 Sept. 2013. Web. 22 Sept. 2013. <<http://en.wikipedia.org/wiki/Goniometer>>.

Goodrich, Megan. "5 Best Ankle Braces for Basketball Players." Hat Trick Sports LLC. Hat Trick Sports, 2004-2013. Web. 14 Sept. 2013.

Halseth, Travis, John W. McChesney, Mark DeBeliso, Ross Vaughn, and Jeff Lien. "THE EFFECTS OF KINESIOTM TAPING ON PROPRIOCEPTION AT THE ANKLE." *Journal of Sports Science and Medicine* 3 (2004): 1-7. Print.

Hamill, Joseph, and Knutzen, Kathleen M. *Biomechanical Basis of Human Movement*. Baltimore: Wolters Kluwer Health/Lippincott Williams and Wilkins, 2009. Print.

Hayashi, M. M. (2000). US Patent 6,056,713. Washington, DC: U.S.

Ibrahim, V., Meyler, Z., & Panagos, A. Ankle Sprains and the Athlete. American College of Sports Medicine. Retrieved from [www.acsm.org](http://www.acsm.org) website.

Induced Stability in Subjects with Chronic Ankle Instability." *Clinical Biomechanics* 17 (2002): 526-235. Print.

Junitha MM, Ashkahn G, Shawn G, Tarun G (2008) Biomechanics of the ankle joint and clinical outcomes of total ankle replacement. *Journal of the Mechanical Behavior of Biomedical Materials*, 1(4), 276-294.

Kaminski, T. W., Hertel, J., Amendola, N., Docherty, C. L., Dolan, M. G., Hopkins, J. T., . . . Richie, D. (2013). Conservative Management and Prevention of Ankle Sprains in Athletes. *National Athletic Trainer's Association Position Statement*, 48(4).

Kumai, T., Takakura, Y., Rufai, A., Milz, S. and Benjamin, M. (2002), The functional anatomy of the human anterior talofibular ligament in relation to ankle sprains. *Journal of Anatomy*, 200(5), 457-465. doi: 10.1046/j.1469-7580.2002.00050.x

Lee, Wilson, Toshiki Kobayashi, Barton Choy, and Aaron Leung. "Comparison of Custom-molded Ankle Orthosis with Hinged Joints and Off-the Shelf Ankle Braces in Preventing Ankle Sprain in Lateral Cutting Movements." *International Society for Prosthetics and Orthotics* 36 (2012): 190-95. Sage Journals. ISPO. Web. 22 Sept. 2013.

"Lexan® PolyCarbonate Plastic." Lexan® PolyCarbonate Plastic. Advanced Gasket & Supply, 21 May 2008. Web. 23 Apr. 2014.

Malin, Scott. "The Danger of Ankle Braces." *HEM Ankle Rehab*. N.p., 2013. Web. 22 Sept. 2013.  
McGuine, Timothy A., Scott Hetzel, John Wilson, and Alison Brooks. "The Effect of Lace-up Ankle

Braces on Injury Rates in High School Football Players." *The American Journal of Sports Medicine* 40 (2012): 49-57. Print.

Milner CE, Soames RW (1998) Anatomy of the Collateral Ligaments of the Human Ankle Joint. *Foot and Ankle International*, 19(11), 757-760. DOI: 10.1177/107110079801901109.

Munn, Joanne, David J. Beard, Kathryn M. Refshauge, and Raymond Y W. Lee. "Eccentric Muscle Strength in Functional Ankle Instability." *American College of Sports Medicine* (n.d.): 245-50. Web. 22 Sept. 2013. <[http://www.setantacollege.com/wp-content/uploads/Journal\\_db/Eccentric%20Muscle%20Strength%20in%20Functional.pdf](http://www.setantacollege.com/wp-content/uploads/Journal_db/Eccentric%20Muscle%20Strength%20in%20Functional.pdf)>.

Norkus SA, Floyd RT (2001) The anatomy and mechanisms of syndesmotric ankle sprains. *Journal of Athletic Training*, 36(1), 68-73.

OO'Connell, P. Common Basketball Injuries Keep your Guard Up. Palumbo, P. M. (1985). US Patent 4,495,942. Washington, DC: U.S. Peters, R. E. (1994). US Patent 5,366,439. Washington, DC: U.S. Peters, R.E. (1998). US Patent 5,836,903. Washington, DC: U.S.

Polito, D., Rucco, J., & Wood, T. (2013). Digitone: A novel soccer goalkeeping device. Unpublished manuscript, Major Qualifying Project, Worcester Polytechnic Institute, Worcester, MA.

Prevents Ankle Roll Guard. from <http://anklerollguard.com/index.html>

"Review of Best Ankle Braces (ASO, McDavid, Swede-O, Pro-Tec)." *Way and Path Ankle Brace Championship Comments*. Way and Path, 30 Apr. 2011. Web. 14 Sept. 2013.

Rijn, R. v. (2010). Acute Ankle Sprains.



- Ross, Scott E., Shelley W. Linens, Cynthia J. Wright, and Brent L. Arnold. "Balance Assessments for Predicting Functional Ankle Instability and Stable Ankles." *Gait & Posture* 34.4 (2011): 539-42. Science Direct. Web. 22 Sept. 2013.
- Slimmon, D., & Bruncker, P. (2010). Sports ankle injuries: Assessment and management. *Australian Family Physician*, 39, 1-22.
- Sports Injury Statistics. (2013). Health Library. From <http://www.lpch.org/DiseaseHealthInfo/HealthLibrary/orthopaedics/stats.html>
- Tanaka H, Mason L (2011) (v) Chronic ankle instability. *Orthopaedic and Trauma*, 25(4), 269-278.
- Tran, P. (2013). *Evaluation of the Anterior Talofibular and Calcaneofibular Ligament in Relation to Supination Ankle Sprains*. Unpublished Review Article. California Polytechnic State University.
- Ubell, Mathew L., James P. Boylan, James A. Ashton-Miller, and Edward M. Wojtys. "The Effect of Ankle Braces on the Prevention of Dynamic Forced Ankle Inversion." *The American Journal of Sports Medicine* 31.6 (2003): 935-40. Web. 22 Sept. 2013.
- Wagner, Phil. "Brace Yourself: Ankle Braces Hurt Knees." *SPARTA POINT: Brace Yourself: Ankle Braces Hurt Knees*. SPARTA POINT, 6 Mar. 2009. Web. 14 Sept. 2013.
- "What Is the Subtalar Joint?" About.com Podiatry. N.p., n.d. Web. 22 Sept. 2013. <<http://foothealth.about.com/od/footanatomy/a/What-Is-The-Subtalar-Joint.htm>>.
- Wilkerson, G. B. (2002). Biomechanical and Neuromuscular Effects of Ankle Taping and Bracing. *Journal of Athletic Training*.
- Wolfe MW, Uhl TL, Mattacola CG, Mccluskey LC (2001) Management of Ankle Sprains. *Am Fam Physician*. 63(1), 93-105.
- Wright, Michelle, Dr., Naomi Hartree, Dr., and John Cox, Dr. "Patient.co.uk - Trusted Medical Information and Support." Patient.co.uk. EMIS, 19 Jan. 2012. Web. 14 Sept. 2013
- Yu, J., Cheung, J.T., Fan, Y., Zhang, Y., Leung, A. K., & Zhang, M. (2007). Development of a finite element model of female foot for high-heeled shoe design. *Clinical Biomechanics*, 23, S31 – S38.

## Appendices

### Appendix A: Table of the Most Commonly Injured Body Sites in Sports

**Table III.** The most common injured body sites in different sports and countries\*

Sport	Most common injured body sites [weighted percentage (%)]					References
Adventure racing	Ankle (23.0)	Shoulder (11.5)	Arm (11.5)	Knee (11.0)	Trunk (11.0)	49
Aeroball	Ankle (80.0)	Knee (9.2)	Foot (6.4)	Hand (3.7)	Head (2.8)	50
American football	Knee (21.0)	Ankle (17.0)	Shoulder (8.4)	Trunk (5.8)	Thigh (4.9)	51-61
Australian football	Thigh (19.6)	Knee (12.3)	Ankle (7.9)	Leg (4.5)	Head (3.8)	36,62-65
Badminton	Ankle (23.5)	Knee (14.0)	Foot (12.5)	Arm (8.0)	Leg (5.4)	66-69
Baseball	Head (41.0)	Hand (29.0)	Leg (8.0)	Arm (6.0)	Ankle (3.5)	54
Basketball	Ankle (15.9)	Knee (10.7)	Trunk (6.5)	Thigh (5.4)	Leg (5.0)	23,54,57,70-82
Cardio kickboxing	Trunk (20.0)	Knee (18.0)	Hip (11.0)	Shoulder (10.0)	Thigh (8.0)	83
Cheerleading	Ankle (26.2)	Knee (10.4)	Trunk (9.4)	Arm (7.0)	Head (6.9)	26,84,85
Cricket	Ankle (17.9)	Knee (15.8)	Shoulder (14.7)	Trunk (12.6)		86
Cycling	Knee (24.3)	Hand (17.7)	Leg (11.9)	Foot (11.8)		57,71,87,88
Dancing	Leg (19.5)	Ankle (17.4)	Trunk (13.9)	Foot (12.0)	Knee (10.4)	12,15,89-94
Equestrian	Arm (22.3)	Head (21.7)	Hand (15.6)	Thigh (8.8)	Leg (7.0)	81,95
Fell walking	Head (28.8)	Ankle (24.0)	Leg (13.6)	Hand (9.1)	Trunk (7.2)	96
Field hockey	Head (34.4)	Ankle (34.0)	Arm (13.6)	Knee (4.1)	Trunk (1.1)	38
Figure skating	Ankle (24.5)	Leg (18.0)	Knee (15.6)	Head (9.8)	Arm (9.2)	35,97
Flag football	Hand (39.0)	Knee (18.0)	Thigh (9.0)	Ankle (8.0)	Foot (4.0)	98
Floorball	Ankle (26.8)	Knee (17.9)	Trunk (8.3)	Head (7.8)	Foot (5.1)	30,99
Gaelic football	Ankle (21.0)	Knee (13.0)	Thigh (13.0)	Shoulder (12.0)	Trunk (7.5)	100
Golf	Trunk (25.6)	Arm (21.2)	Shoulder (15.8)	Hand (14.9)	Head (6.1)	101,102
Gymnastics	Ankle (32.3)	Arm (25.9)	Knee (9.4)	Trunk (6.8)	Hand (4.4)	14,27,81,103-107
Handball	Hand (31.2)	Ankle (13.5)	Knee (10.7)	Arm (6.9)	Leg (6.6)	23,39,81,108,109
Hurling/camogie	Hand (27.1)	Head (20.2)	Ankle (8.6)	Leg (8.4)	Head (6.5)	110,111
Ice hockey	Head (21.4)	Knee (14.7)	Thigh (10.6)	Trunk (6.1)	Shoulder (5.6)	81,112-116
Jockey	Head (18.8)	Ankle (10.7)	Trunk (10.7)	Shoulder (9.6)	Knee (7.8)	117
Kitesurfing	Ankle (14.1)	Foot (14.1)	Head (13.7)	Trunk (12.9)	Knee (12.9)	118
Lacrosse	Knee (20.3)	Ankle (18.5)	Head (12.7)	Hand (9.9)	Shoulder (3.8)	119
Luging	Head (12.8)	Hand (11.3)	Trunk (8.9)	Shoulder (7.6)	Knee (7.6)	120
Marathon	Knee (31.7)	Foot (27.5)	Ankle (10.1)	Leg (6.8)	Thigh (1.3)	121
Martial arts	Arm (45.0)	Ankle (21.0)	Head (20.0)	Trunk (5.0)	Knee (4.4)	106,122
Motorcycle racing	Hand (22.4)	Arm (18.5)	Ankle (16.4)	Shoulder (14.6)	Knee (12.2)	123,124
Mountaineering	Ankle (40.0)	Knee (10.7)	Foot (7.9)	Leg (7.4)	Arm (5.6)	22
Netball	Ankle (39.8)	Knee (17.8)	Hand (10.5)	Head (8.7)	Leg (5.6)	1,30,76,125-127
Orienteering	Ankle (29.8)	Knee (18.1)	Leg (14.8)	Foot (13.3)	Thigh (5.0)	128-131
Parachuting	Ankle (32.9)	Leg (26.9)	Trunk (10.8)	Arm (3.1)	Hand (3.1)	132,133
Paragliding	Trunk (34.9)	Ankle (21.0)	Arm (13.4)	Knee (2.8)		134

Continued next page

## Appendix B: Project Team's Objective Tree

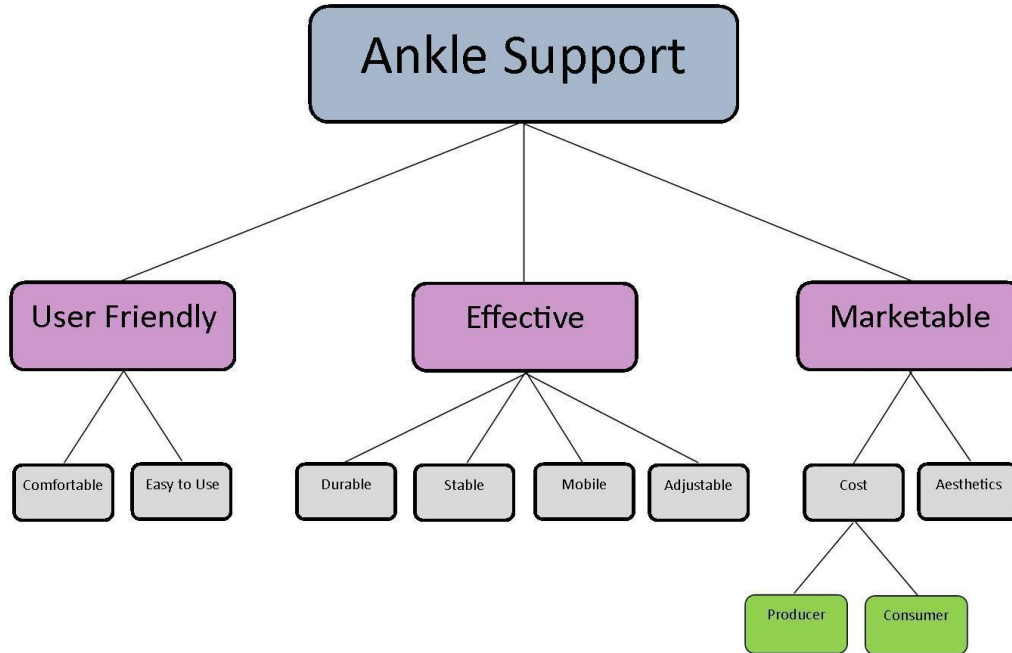

## Appendix C: Project Team's Pairwise Comparison Chart

Objectives	Comfortable	Easy to Use	Durable	Stable	Mobile	Adjustable	Aesthetics	Cost	Total
Comfortable	X	1/2	1/2	0	0	1/2	1	0	2.5
Easy to Use	1/2	X	1	0	0	0	0	1	2.5
Durable	1/2	0	X	1/2	1/2	0	1	1	3.5
Stable	1	1	1/2	X	0	1	1	1	5.5
Mobile	1	1	1/2	0	X	1	1	1	5.5
Adjustable	1/2	1	1	0	0	X	1	1	4.5
Aesthetics	0	1	0	0	0	0	X	0	1
Cost	1	0	0	0	0	0	1	X	2

## Appendix D: FBD of Single Leg Stance

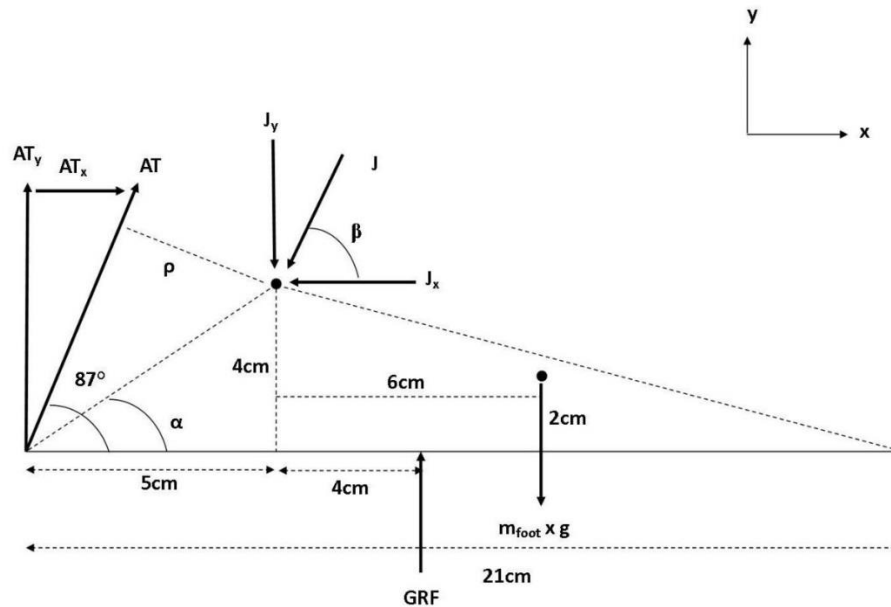

### Assumptions:

- Mass 70kg (~154lbs)
- Gravity =  $9.81\text{m/s}^2$
- Foot is a rigid structure (only movement in dorsi-plantar-flexion is considered)
- Tibio-talar joint is frictionless
- Tibialis anterior muscle is excluded (not active during standing)

### Dimensions:

- length of foot = 21cm (heel to metatarsals)
- center of rotation of tibio-talar joint – 5 cm anterior and 4 cm superior to the point of action of the AT on the heel
- Achilles tendon (AT) acts at an angle  $87^\circ$  to the horizontal axis
- Ground reaction force (GRF) = weight of body – weight of foot
  - o Acts 4 cm anterior to the center of rotation of the tibio-talar joint
- Center of mass of foot – 6 cm anterior and 2 cm below center of rotation of tibio-talar joint
- $m_{\text{foot}} = 1.5\%$  of total body mass = 1.05 kg
- joint force reaction (J) acts at angle  $\beta$  to the horizontal
- moment arm,  $\rho$ , to the AT

## Appendix E: Equations for FBD of Single Leg Stance

1.  $\alpha = \tan^{-1}\left(\frac{4 \text{ cm}}{5 \text{ cm}}\right)$
2.  $\theta = (87^\circ - \alpha)$
3.  $\rho = \sqrt{(4 \text{ cm})^2 + (5 \text{ cm})^2} \sin \theta$
4.  $\sum \text{anticlockwise moments} - \sum \text{clockwise moments} = 0$   
 $GRF(4 \text{ cm}) - \left( (AT \times \rho) + (m_{\text{foot}} \times g \times 6 \text{ cm}) \right) = 0$
5.  $\sum F_x = 0$   
 $AT_x - J_x = 0$
6.  $\sum F_y = 0$   
 $GRF + AT_y - J_y - (m_{\text{foot}} \times g) = 0$
7.  $J = \sqrt{J_x^2 + J_y^2}$   
 $\beta = \tan^{-1} \frac{J_y}{J_x}$

## Appendix F: Email to Undergraduate Students

Hello WPI Students!

We are currently seeking students interested in participating in our MQP research. We are researching the effects of different types of ankle braces and the forces applied on the ankle during athletic activity.

Participation would require a few meetings over the course of 3 months with each test lasting approximately 30 minutes. These sessions will involve balance and ankle stability testing with and without ankle braces. The ankle braces used will be provided. There will be no running during the testing whatsoever. This study requires the use of athletic shoes of the participant's choice.

If you are interested, please e-mail [braceyourself@wpi.edu](mailto:braceyourself@wpi.edu) at your earliest convenience. Participation in the study is completely voluntary.

Thank you and have a nice day.

Ximena Auger  
Aleksandra Larue  
Nicole  
McDonough  
Isabel Pagliaccio  
Asher Plange

## Appendix G: Informed Consent Form



### **Informed Consent Agreement for Participation in a Research Study**

---

Investigators:

Primary – Brian J. Savilonis

Student - Ximena Auger, Aleksandra R. LaRue, Nicole M. McDonough, Isabel Pagliaccio, and Asher Plange

**Contact Information:**

ME Department WPI  
100 Institute Road  
Worcester, MA 01609  
Tel. 508-831-5868 Email: [bjs@wpi.edu](mailto:bjs@wpi.edu)

Or Email: [braceyourself@wpi.edu](mailto:braceyourself@wpi.edu)

**Title of Research Study:** Design of an Adjustable Ankle Support System

**Introduction:**

You are being asked to participate in a research study. Before you agree, however, you must be fully informed about the purpose of the study, the procedures to be followed, and any benefits, risks or discomfort that you may experience as a result of your participation. This form presents information about the study so that you may make a fully informed decision regarding your participation.

**Purpose of the Study:**

For this study this project team is testing ankle stability. In order to collect data testing subjects will take part in three types of stability testing: preliminary testing, detachable sole testing, and tilt testing. This information will be used to test a prototype the project team designed.

**Procedures to be followed:**

Before starting preliminary testing you will be given a questionnaire in order to collect basic background information including: height, weight, sex, amount of physical activity and history of ankle injury (Appendix E). In order to protect your privacy you will

be given a subject number. To begin preliminary testing you will stand on the foam pad without shoes and will be instructed to assume the initial starting position which involves putting your hands on your hips, closing your eyes, and lifting one leg slightly off the ground, while balancing on the other leg. You will attempt to remain in this position for one minute while the investigators mark down a single tally for every error that occurs during that time. At the end of the test the investigators will determine your total error score by summing up the error tallies. The test will be conducted again while you are wearing a “gold standard” brace and again while wearing the project team’s prototype in order to provide a comparison between the non-braced and braced condition. This procedure will be repeated for both of your ankles. Based on your total error score the investigators will determine whether you are suited for further testing.

Once you have successfully completed preliminary testing you will be testing your ankle stability with and without braces using a detachable sole. You will go through two trials for each of the conditions: without a brace, with the three gold standard braces we determined were effective for the different stages of ankle healing on the market now, and with the project team’s prototype. In this part of testing you will attach a detachable sole apparatus to the bottom of your shoe; this sole has an off-center fulcrum that is 29.5mm long which causes the foot to invert at an angle of 20 degrees. This angle is a safe amount for the ankle to invert because it has been shown that the ankle does not receive damage until an inversion angle of 30 degrees. During these trials you will step down onto a force plate from twice the height of that force plate using the foot with the sole attached. The force plate will then read the force distribution for that foot and gives the inversion time by listing the time the fulcrum initially hit the force plate and the time that the side of the subject’s foot hits the ground.

Finally you will undergo a secondary stage of testing that will measure the angle of rotation of the ankle using a tilt test apparatus. This apparatus involves a hinged door which releases to an angle of 20 degrees because as noted above an angle below 30 degrees is safe. You will stand on the apparatus with one foot on the hinged door while the other foot is on the stable platform. A goniometer will then be attached to your calf and ankle region using pre wrap and surgical tape in order for the project team to calibrate the subject’s natural stance. Once you acknowledge that you are ready to begin testing the investigator will release the platform randomly within the next minute that way you don’t know when the door is going to drop. Once the ankle inverts the goniometer will record the angle of inversion from the initial starting angle. Following the procedure of the previous test, you will go through two trials for each of the conditions: without a brace, with the three gold standard braces we determined were effective for the different stages of ankle healing on the market now, and with the project team’s prototype. In all of these trials you will be wearing an athletic shoe to insure that the type of shoe being worn does not have an impact on the results.



**Risks to study participants:**

There is some possibility of minor ankle discomfort due to the positioning that the apparatuses place your ankle in. There is a risk of skin irritation from the skin contact to the pre-wrap and surgical tape used to secure the goniometer to your leg. You should expect some muscle soreness to develop as a consequence of the inversion and eversion movements of the ankle muscles.

**Benefits to research participants and others:**

There is no direct benefit to you.

**Record keeping and confidentiality:**

At the start of the study you will be assigned a test subject number that will identify you throughout the testing stages. Your information will be entered into a Microsoft Access Database used by the project team to track your results. Records of your participation in this study will be held confidential so far as permitted by law. However, the study investigators, the sponsor or its designee and, under certain circumstances, the Worcester Polytechnic Institute Institutional Review Board (WPI IRB) will be able to inspect and have access to confidential data that identify you by name. Any publication or presentation of the data will not identify you.

**Compensation or treatment in the event of injury:**

In the unlikely event of physical injury resulting from participation in the research, you understand that medical treatment may be available from WPI, including first aid emergency care, and that your insurance carrier may be billed for the cost of such treatment. No compensation for medical care can be provided by WPI. You further understand that making such medical care available, or providing it, does not imply that such injury is the fault of the investigators. You do not give up any of your legal rights by signing this statement.

**For more information about this research or about the rights of research participants, or in case of research-related injury, contact:**

Prof. Brian J. Sivilonis, Mechanical Engineering Department, WPI, 100 Institute Road, Worcester, MA (Tel. 508-831-5686) or email at [bjs@wpi.edu](mailto:bjs@wpi.edu). You may also contact the chair of the WPI Institutional Review Board (Prof. Kent Rissmiller, Tel. 508-831-5019, Email: [kjr@wpi.edu](mailto:kjr@wpi.edu)) or WPI's University Compliance Officer (Michael J. Curley, Tel. 508-831-6919).

**Your participation in this research is voluntary.** Your refusal to participate will not result in any penalty to you or any loss of benefits to which you may otherwise be entitled. You may decide to stop participating in the research at any time without penalty or loss of other benefits. The project investigators retain the right to cancel or postpone the experimental procedures at any time they see fit. Data obtained in this experiment will become the property of the investigators and WPI. If you withdraw from the study, data already collected from you will remain in the study.

**By signing below,** you acknowledge that you have been informed about and consent to be a participant in the study described above. Make sure that your questions are answered to your satisfaction before signing. You are entitled to retain a copy of this consent agreement.

\_\_\_\_\_

Date: \_\_\_\_\_

Study Participant Signature

\_\_\_\_\_

Study Participant Name (Please print)

\_\_\_\_\_

Date: \_\_\_\_\_

Signature of Person who explained this study

## Appendix H: Questionnaire

### MQP: Ankle Stability Testing

In this test we will be testing the stability of your ankle by testing your ability to balance on a soft surface for a minute.

#### To be filled out by Subject:

##### General Information:

Subject Number:		Date of Birth:	
<input type="checkbox"/> Male <input type="checkbox"/> Female	Height:	Foot Length (in):	Foot Width (in):
Do you play a varsity sport? <input type="checkbox"/> Yes If yes please list which ones: _____ <input type="checkbox"/> No			
Do you play recreational sports? <input type="checkbox"/> Yes If yes please list which ones: _____ <input type="checkbox"/> No			
How much time do you spend per week working out? <input type="checkbox"/> >10 hours a week <input type="checkbox"/> 6-10 hours a week <input type="checkbox"/> 3-5 hours a week <input type="checkbox"/> <2 hours a week			

##### Ankle Information:

Have you ever sprained your ankles (if yes which one)? \_\_\_\_\_

Have you ever been diagnosed with weak joints (ankle and or knee please specify)? \_\_\_\_\_

#### To be filled out by Tester: \_\_\_\_\_

Range of Motion	Inversion	Eversion	Planter Flexion	Dorsiflexion

#### To be filled out by Tester: \_\_\_\_\_

Range of Motion	Inversion	Eversion	Planter Flexion	Dorsiflexion

## Appendix I: Preliminary Testing Error Score Sheet

Subject Number: \_\_\_\_\_

Tester Name: \_\_\_\_\_

<b>Error Score Marks</b>	<b>Test 1 (no pad or brace) Trial # _____</b>	<b>Test 2 (pad, no brace) Trial # _____</b>
Removing hands from hips		
Lifting the forefoot of the heel		
Opening eyes		
Touching non-weight bearing foot on ground		
Remaining out of position for more than 5 seconds		
<b>TOTAL ERROR SCORE</b>		

<b>Error Score Marks</b>	<b>Test 3 (pad and McDavid) Trial # _____</b>	<b>Test 4 (pad and PLS) Trial # _____</b>
Removing hands from hips		
Lifting the forefoot of the heel		
Opening eyes		
Touching non-weight bearing foot on ground		
Remaining out of position for more than 5 seconds		
<b>TOTAL ERROR SCORE</b>		

<b>Error Score Marks</b>	<b>Test 5 (pad and PHS) Trial # _____</b>	
Removing hands from hips		
Lifting the forefoot of the heel		
Opening eyes		
Touching non-weight bearing foot on ground		
Remaining out of position for more than 5 seconds		
<b>TOTAL ERROR SCORE</b>		

## Appendix J: Detachable Sole Apparatus and Force Diagram

View of detachable sole from the bottom:

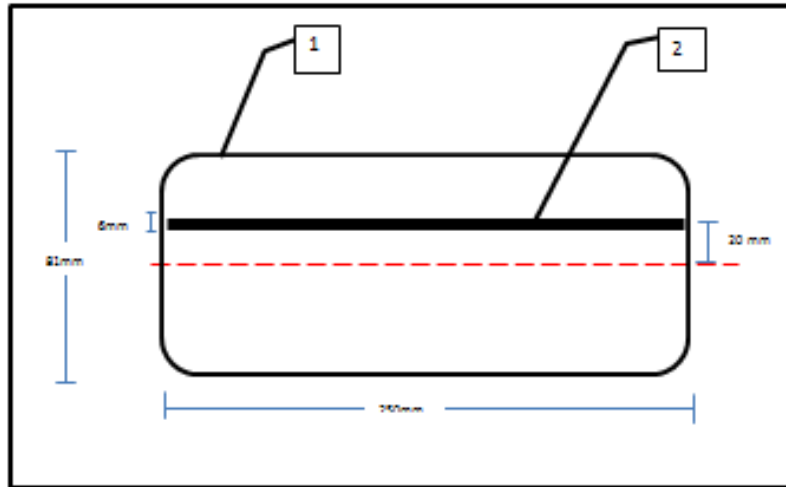

\*From this view the fulcrum comes out of the page 29.5mm.

Table of Parts:

Part #	Part	Description	Material	Number Needed
1	Detachable sole	250mm long, 81mm wide, depth to be determined based on strength of plastic	ABS Plastic, PLA, Nylon (options)	1
2	Fulcrum	250mm long, 6mm wide, 29.5mm deep	ABS Plastic, PLA, Nylon (options)	1

Detachable Sole Apparatus with forces (view from back):

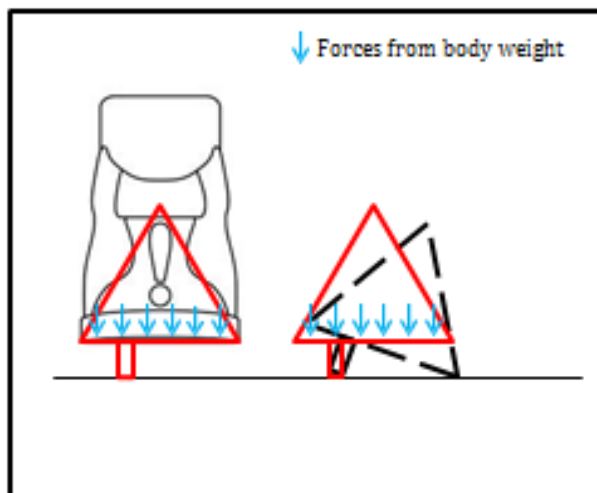

# Appendix K: Gantt Chart

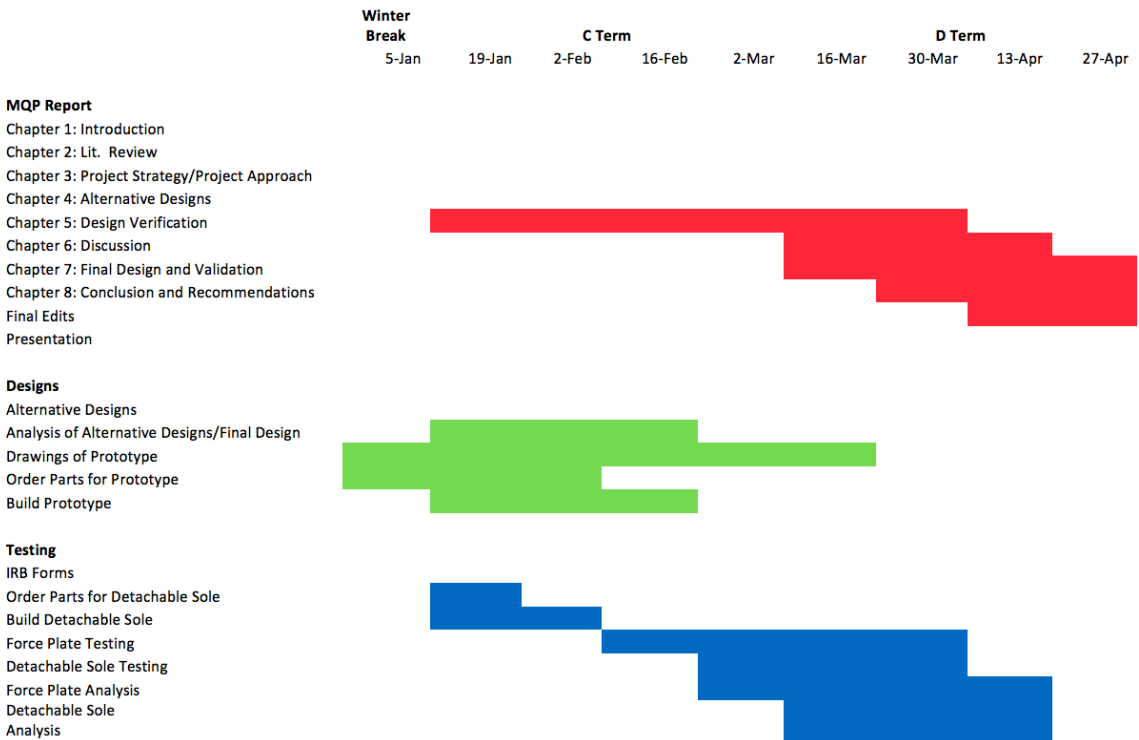
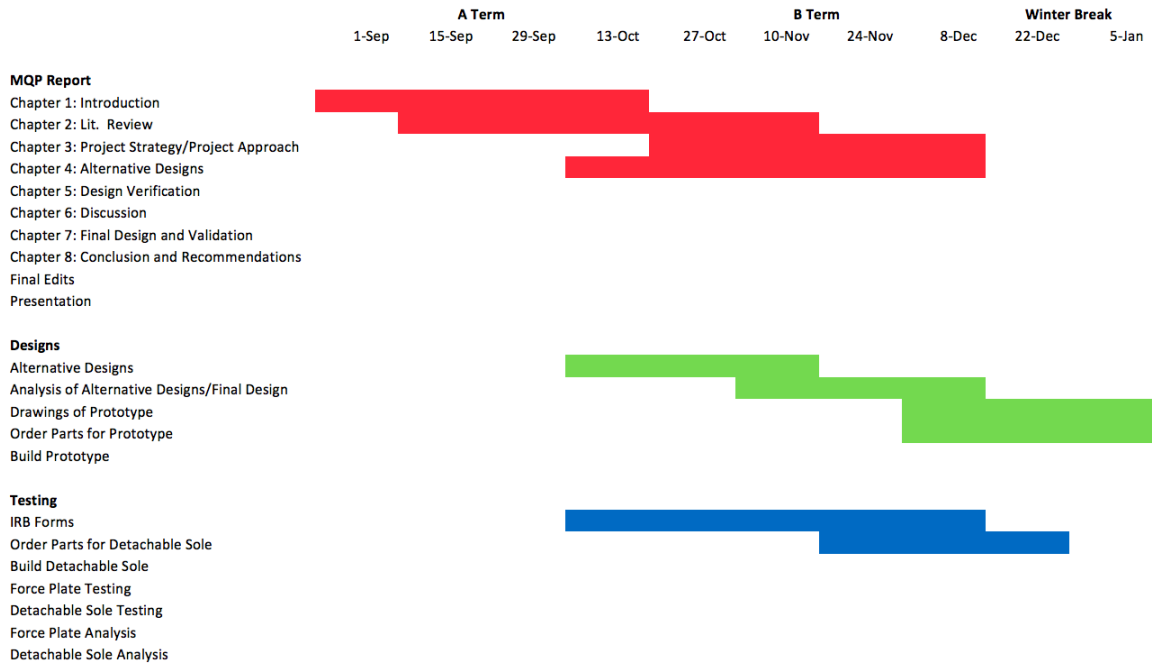

## Appendix L: Linear Responsibility Chart

	Ali	Ximena	Nicole	Asher	Isabel
<b>MQP Report</b>					
Chapter 1: Introduction	1	3			
Chapter 2: Lit Review	3	2	2	2	2
Chapter 3: Project Strategy/Project Approach	1	3			
Chapter 4: Alternative Designs	2	2	3	2	1
Chapter 5: Design Verification	2	1	2	3	2
Chapter 6: Discussion	2	2	2	1	2
Chapter 7: Final Design and Validation	2	2	1	2	3
Chapter 8: Conclusion and Recommendations	3	1	2	2	2
Final Edits of Report	1	2	2	2	2
Presentation	1		3		
<b>Testing</b>					
IRB Forms	1	3	2	2	
Order Parts for Apparatuses				1	
Preliminary Testing without Braces	2	1		2	
Preliminary Testing with Braces	2	1		2	
Build Apparatuses			2	2	1
Rapid Stability Testing without Braces	2	2	1		
Rapid Stability Testing of Current Products	2	2	1		
Rapid Stability Testing of Prototype	2	2	1		
Analysis	3	2	2	2	1
<b>Designs</b>					
Alternative Designs	2	1	2	2	2
Analysis of Alternative Designs/Final Decision	2	2	3	2	2
CAD Drawings of Prototype			1	2	
Order Parts for Prototype				1	
Build Prototype	1	2	2	2	2
Make Guidelines/Recommendations	2	1	2	2	2

1 = Primary Responsibility (Leader)

2 = Support/Work

3 = Review/Edit

## Appendix M: Average Elapsed Time for All Test Subjects

Time Values	No Brace	Store Brace	Our Brace	
Subject Number	No Brace	McDavid Brace	Prototype Brace (High Support)	
1	0.45	0.48	0.46	
2	X	X	X	
3	0.47	0.45	0.71	
4	X	X	X	
5	X	X	X	
6	0.32	0.37	0.38	
7	0.55	0.59	0.54	
8	X	X	X	
9	0.43	0.31	0.45	
10	0.53	0.37	0.7	
11	X	X	X	
12	0.44	0.44	0.54	
13	0.58	0.88	0.48	
14	0.42	0.45	0.59	
15	X	X	X	
16	0.26	0.29	0.31	
17	0.21	0.27	0.22	
18	0.46	0.53	0.64	
19	0.3	0.66	0.44	
20	0.32	0.48	0.55	
<b>Average</b>	0.416923077	0.469285714	0.500714286	
<b>Standard Deviation</b>	0.107835854	0.156317638	0.134826041	0.132993

Subject Number	Percent Increase from NB to McDavid Brace	Percent Increase from NB to Prototype Brace (HS)
1	6.67%	0.022222222
2	X	X
3	-4.26%	0.510638298
4	X	X
5	X	X
6	15.63%	0.1875
7	7.27%	-0.018181818
8	X	X
9	-27.91%	0.046511628
10	-30.19%	0.320754717
11	X	X
12	0.00%	0.227272727
13	51.72%	-0.172413793
14	7.14%	0.404761905
15	X	X
16	11.54%	0.192307692
17	28.57%	0.047619048
18	15.22%	0.391304348
19	120.00%	0.466666667
20	50.00%	0.71875