



WPI

The Design of a Harmonic Radar System

A Major Qualifying Project Submitted to the Faculty of the WORCESTER POLYTECHNIC INSTITUTE In partial fulfillment of the requirements for the Degree of Bachelor of Science in Electrical and Computer Engineering

By:
Denver Cohen
December 2017

Submitted to:

Stephen Bitar, ECE Faculty

Acknowledgements:

I'd like to thank a few people for the success of this project over the last 14 weeks.

Professor, Stephen Bitar: For his guidance and critical insight for this project. To which I would have not been able to complete this project without. Also for his genuine love and excitement of electrical engineering which has shaped the engineer I have become. I will sorely miss our chats and his encouragement.

Professor, Shamsur Mazumder & Professor, Reinhold Ludwig: For the use of the new RF lab in Atwater Kent. This project would not have viable without the use of the spectrum analyzer, rf signal generator, vector network analyzer, and RF sweeper.

Professor, John McNeil: For insight and discussion relating the backscatter tag modulation.

Professor, Sergey Makarov: For his generous loan of a WR-75 waveguide antenna and sma to waveguide adapter. This piece was a difficult procurement item and without having it loaned to me from Prof Makarov, I would not have been able to successfully complete this project.

Professor, William Appleyard: For use of the ECE shop in Atwater Kent, the numerous screws, nuts, and scrap stock metal use, and most importantly his guidance and encouragement when building my software defined radio chassis.

To my friends and family, who have generously supported me the last 14 weeks and my quest of creating this system.

Abstract:

This project involves using a software defined radio in creation of a harmonic radar system. A harmonic radar system works by sending out some type of stimulus signal to a harmonic reflecting tag. The tag takes in stimulus at a lower frequency and generates a second harmonic that is then re-radiated back out to a receiving system. The receiving system then processes and extracts information from it. The use of a software defined radio system allows for all kinds of information extraction through the use of baseband processing software. A few types of tags were created, a passive reflector tag, a digital modulation tag, and a analog audio tag. The analog audio tag was able to recover sound from a remote location passively and was the focus of the majority of the project testing.

Executive Summary:

This project involves using a software defined radio from Ettus research in creation of a harmonic radar system. A harmonic radar system works by sending out some type of stimulus signal to a specially constructed harmonic reflecting tag. The tag takes in stimulus energy at a lower frequency and generates a second harmonic of that frequency that is then re-radiated back out to a receiving system. The receiving system then processes this data and can extract information from it. The use of a software defined radio system allows for very fast development cycles and all kinds of information extraction through the use of baseband processing software. The following image is a basic overview of how a harmonic radar system works.

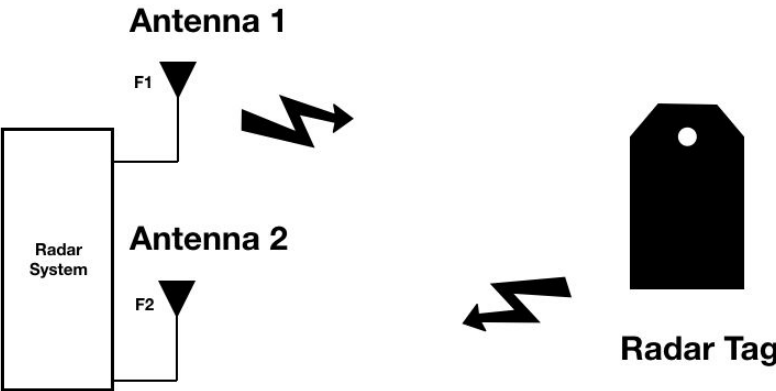

This project created a full radar system and necessary parts to extra audio data from a passive harmonic radar tag. The tag consisted of a mixer diode for harmonic content generation and a transformer and microphone combination. The tag was subjected to loud music and the audio was recovered from a computer running the specially designed baseband processing software in GNUradio. GNUradio is a flow block based programming language for signal analysis with software defined radios. It allows setup of the software defined radio's parameters and tuning values. The software runs on a ubuntu linux machine with sufficient processing power.

Table of Contents

Acknowledgements:	1
Abstract:	2
Executive Summary:	3
Table of Contents	4
Table of Figures	5
Introduction:	6
Section 1: Background Research	6
Radar System:	7
Harmonic Tag (Radar Tag):	8
Full System Overview:	10
Software Defined Radio	11
Gnuradio as Baseband Processor	12
Section 2: Initial Design Considerations	12
Frequency Decision	13
SDR Decision	14
LNB Decision	14
Antenna Decision	15
5.875GHz Antenna	15
11.75GHz Antenna	15
Amplifier	16
Section 3: Methodology	25
Section 4: Tag design	34
Section 5: Results	41
Section 6: Conclusion	42
Bibliography	43

Table of Figures

Figure Number	Page Number
Figure 1	7
Figure 2	9
Figure 3	9
Figure 4	10
Figure 5	12
Figure 6	15
Figure 7	16
Figure 8	17
Figure 9	18
Figure 10	19
Figure 11	20
Figure 12	21
Figure 13	21
Figure 14	22
Figure 15	23
Figure 15	23
Figure 17	24
Figure 18	25
Figure 19	26
Figure 20	27
Figure 21	28
Figure 22	29
Figure 23	29
Figure 24	30
Figure 25	31
Figure 26	32
Figure 27	33
Figure 28	34
Figure 29	35
Figure 30	35
Figure 31	36
Figure 32	36
Figure 33	37
Figure 34	38
Figure 35	39
Figure 36	40
Figure 37	40
Figure 38	41

Introduction:

The objective of this project is to design and create a harmonic radar system within the GHz RF band and an associated tag. The system will utilize a software defined radio as a digitizer and GNU radio running on a suitable computer as the back end processing. The focus of the project is on the radar system (transmit and receive chain) and on tag creation. The tag should be of the smallest form factor possible and be created out of standard materials.

A tag and radar system was designed in the 5.8 GHz ISM band and the 11.7 GHz Ku band. Three types of tags were demonstrated. The first being a solely reflective tag, the second being

a digital modulation based tag, and a third tag that is meant for human speech capture. The system was realized using a 4 watt 5.8 GHz amplifier and a Ku band low noise block downconverter. Assorted RF components are spread throughout the system to match gains and reduce self created harmonics.

Section 1: Background Research

With the increased development in recent years of software defined radio there has become a critical point where achieving previously complex systems can be achieved within software with minimal external hardware. The software aspect provides great flexibility and speeds up the development cycle between iterations of full RF systems. Harmonic Radar is a complex RF system that can now benefit from signal processing through the use of software defined radio basebands. This project seeks to develop a suitable harmonic tag and use a software defined radio with minimal external RF hardware to achieve a working system where the tags presence can be sensed with confidence. A stretch goal of this project is to create tags that have unique signatures or transmit some type of data back to the harmonic radar system. Some ideas for these unique signatures are one time changes of the tag itself, such as corrosion or weathering. Data could be temperature related, humidity related or potentially speech or movement related.

Harmonic Radar is the use of a transmit signal (F_1) over free space to a specially designed tag receiver. The tag receiver doubles the frequency of the original transit from F_1 to F_2 . F_2 is the second harmonic of F_1 . This requires the use of at minimum two antennas, one for the transmit signal F_1 and one for the receive signal F_2 . The antennas should be of suitable resonant frequency for the intended operational frequency.

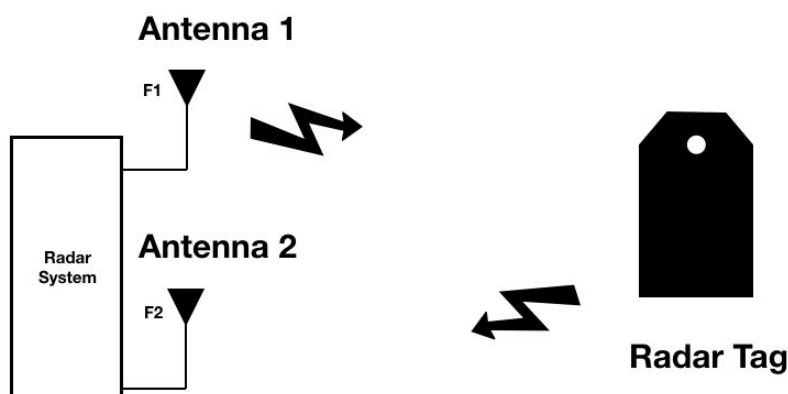

Figure 1: Very Basic Overview of Harmonic Radar System. Note two antennas are used one in the Receive path and one in the Transmit Path.

Radar System:

Harmonic radars are unlike regular radar systems that rely on signal reflections from the environment in front of their antennas. Harmonic systems rely on harmonically related reflections from specialized tags that double the incoming radio frequency energy. There are many types of radar systems and modulation techniques, such as continuous wave, doppler, frequency modulation, and frequency hopping. In the most basic of radar systems the continuous wave radar is used for excitation of the tag. The continuous wave radar transmits a single frequency carrier and listens for the reflection. In this scheme a simple tuned detector can be used to observe the magnitude of the return signal. The magnitude coupled with a precise time can give you the distance to the target object. More sophisticated systems can recover the frequency and determine its phase, magnitude and absolute value. This is useful in determining range with greater accuracy and velocity of the target. Harmonic radar systems usually recover frequency components and magnitude. The goal of a harmonic radar system is to recover the presence of a harmonic tag. Due to the frequency translating aspect of the tag itself phase recovery and time recovery is not usually used because of varying phase and time response in the doubling scheme from tag to tag. This limits the response to magnitude and frequency components only unless each tag is calibrated and only one is used.

The most useful aspect of a harmonic radar is the fact it's tag produces this second harmonic frequency component. This component is unnatural in the sense that the environment around the tag does not produce this. If a second harmonic is then seen by the receiving antennas the presence of the tag can be known. Clutter is the radar terminology used to describe spurious unwanted returns from a radars probing transmission, usually called echoes, other than the intended signal. Clutter is usually linked to physical objects in the beam width of the transmission that return unwanted signals. This could be anything from tree limbs, rocks, changes in air density and air turbulence, anything physical that could get in the way and produces a reflection at the radars target frequency. Harmonic tags allow this clutter echo to be completely cancelled as the natural environment does not produce rectification that causes a second harmonic to be generated. This increases the signal to noise ratio of the return echo greatly. Harmonic tags usually work on a simple diode doubler principal. Some harmonic radars do find clutter in their echoes from non-linear junctions of electronic devices that happen to be tuned to the same frequencies. Having both a resonant circuit at the same frequency of the radar and a non-linear junction is incredibly improbable but with many integrated circuits used in a normal electronic device the probability goes up of a return signal. Multiband harmonic radar systems and tags have been designed to minimize this particularly small case of clutter.[7] Systems have also been designed without specific tags but wideband receive architectures looking for harmonic reflections from electronic devices as a way of detecting the presence of electronics in an environment. The reflection from a harmonic radar tag can also be called backscatter.

Harmonic Tag (Radar Tag):

The harmonic tag is the most important piece of a harmonic radar as it determines the ability of the radar to detect the presence of the tag itself. The tag consists of a non-linear junction such as a diode and two tuned elements. The first tuned element is of resonance with F1 and the second tuned element is of resonance with F2. The tag can be designed with many different antenna types such as monopoles, dipoles, patch antennas and more exotic antennas such as loops, fractals, and other planar geometries. The selection of the non-linear junction device is of critical importance to the operation of the actual system. The conversion from F1 to F2 is dependent on many factors but its overall efficiency is called the conversion efficiency[2]. In many tag designs the designers use a schottky diode for its low forward voltage and its fast switching action. Conversion Efficiency (CE) is calculated by extracting the incident power of F1 at the tag and then dividing the power output at the doubled frequency F2 of the tag by it (EQ1) .[2]

$$\text{Conversion Efficiency \% (CE)} = \frac{P_{F2dBm}}{P_{F1dBm}}$$

EQ1

A typical tag design schematic is shown below. It consists of two antennas one of length λ_1 and λ_2 corresponding to F1 and F2. The tag also has a doubler component which is typically a schottky diode with low a low forward voltage. A critical component of the radar tag is to DC balance the two sides so that the diode can continue to rectify (swing through forward and reverse bias) and not just conduct at a constant forward bias. This is the job of L1 in figure 2. L1 balances the two antennas at an equal voltage potential.

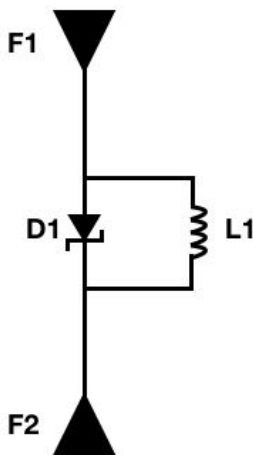

Figure 2: A typical tag design with two antennas tunes to F1 and F2 a doubling schottky diode D1 and a DC return path inductor L1.

The biasing of the schottky diode is of great effect to the conversion efficiency of the tag. Many schemes have been employed to increase conversion efficiency by moving the operating point

of the diode into a more sensitive region. In Tahir and Brooker's study on bias of D1 they simulated that moving the operating point into a more sensitive region would increase conversion efficiency. Unfortunately their measured results did not correlate with their simulations[6]. Their biasing scheme was using a photodiode and a red laser as a light source to produce current to flow into D1. Although the biasing scheme seemed to fail in their study the potential for this idea to work still has merit. Biasing schemes should be looked at in my study to increase conversion efficiency.

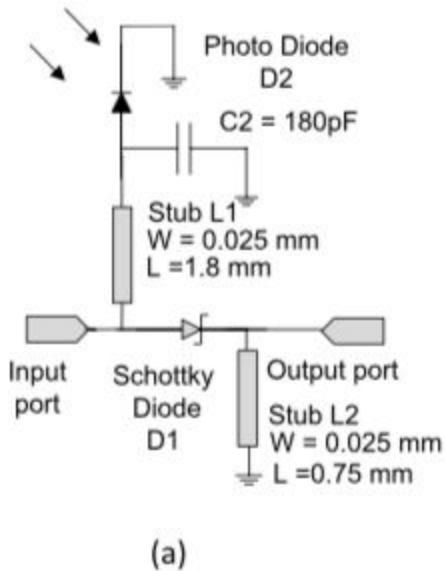

Figure 3: Taken from Tahir and Brooker[6]. A Photodiode D2 and capacitor C2 form a voltage source to forward bias the diode D1. L1 is a decoupling network from the input port which is the lower frequency input. L2 forms the voltage source return path to ground so the diode can conduct. The output port is the doubled frequency of the input port.

Full System Overview:

The full system overview for a harmonic radar is presented in the figure below.

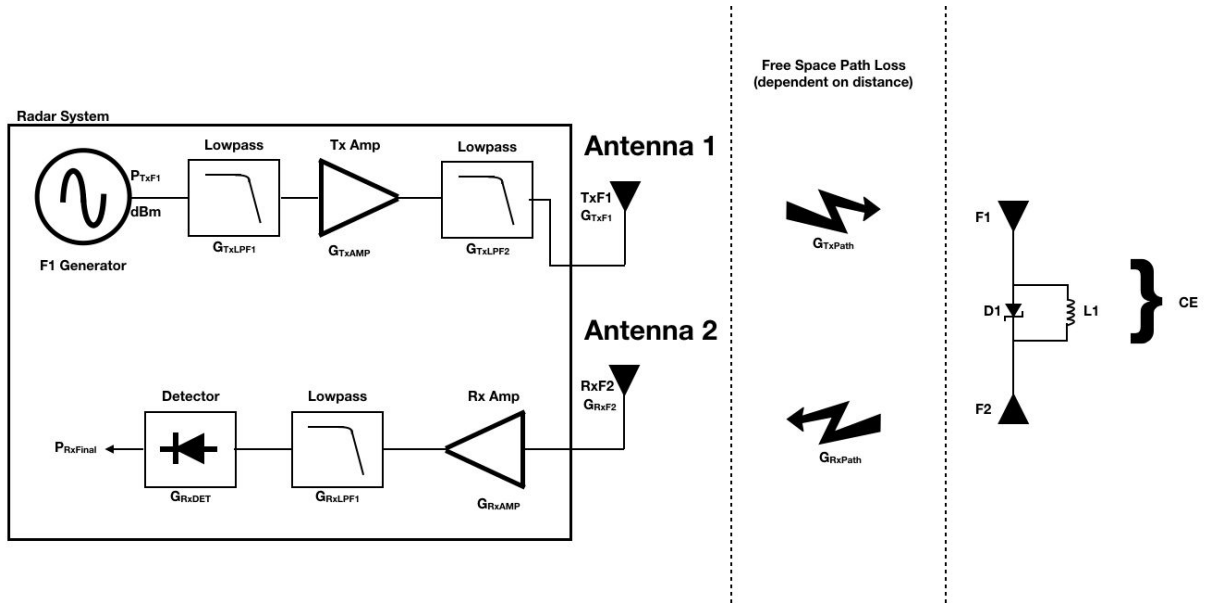

Figure 4: Harmonic radar works upon transmitting one frequency F1 with some X dBm of power. This RF energy excites a non nearfield tag that consists of an element that is tuned to F1. The captured energy is then frequency doubled by the use of a nonlinear element such as a diode. The doubled energy excites a second element tuned to 2 * F1. This second element now radiates this energy into free space. There is expected conversion loss in this tag and this will be a metric considered tag efficiency[2].

The final power seen by the detector is a linear transform of the gains throughout the system following figure 3 above.

$$P_{RxFinal}(dBm) = P_{TxF1} - G_{TxLPP1} + G_{TxAMP} - G_{TxLPP2} + G_{TxF1} - G_{TxPath} - G_{TAG} - G_{RxPath} + G_{RxF2} + G_{RxAMP} - G_{RxLPP1} + G_{RxDET}$$

EQ 2

The gain of the tag can be found by taking the logarithm of the powers as shown in EQ1 or by taking the final conversion efficiency and using the following equation.

$$G_{TAG} (dB) = 10 \text{Log}_{10}(1 + \%)$$

EQ 3

The two path loss terms can be modeled using Friis path loss equation below

$$P_{rx} (dB) = P_{Tx} + G_{Tx} + G_{rx} + 20 \text{Log}_{10}\left(\frac{\lambda}{4\pi D_r}\right)$$

EQ 4

Where:

P_{Tx} = Power of the Transmitter in dB

G_{Tx} = The gain of the Transmitter's antenna

G_{Rx} = The gain of the Receiver's antenna

λ = The Transmit wavelength

D_r = The distance between the Transmitter and Receiver

From this path loss equation it becomes obvious that as the frequency goes up the path loss also goes up. The harmonic radar tag has to convert the energy received and then retransmit it,

thus incurring another path loss, except this time at double the frequency. This makes the complete system gain extremely low the higher the fundamental frequency goes.

Software Defined Radio

A software defined radio is a radio frequency front end (transceiver) coupled with high performance analog to digital converters and digital to analog converters with glue logic to support the operation. The front end usually consists of a chip that contains low noise amplifiers, radio frequency mixers, filters and an ADC in the receive chain. In the transmit chain it contains DACs, filters, mixers and power amplifiers. The front end chips are usually extremely wideband, ranging from tens of megahertz to single digit gigahertz or even tens of gigahertz. The chips usually contain one or more synthesized oscillators to drive the receive and transmit mixers to the frequencies that are requested from the software. The front end chips are software configurable in all their aspects, from the gain of different stages, to the frequency the oscillators are tuned to, and the filter bandwidths. This makes the front ends basic very wideband superheterodyne radios. The front end chips input and output radio frequency on the analog side and digital imaginary and real components of the signals on the digital side. This makes them a completely universal software controllable radio. A software defined radio usually has a FPGA and some type of physical layer controller. The FPGA does digital up conversion and digital down conversion of the baseband digital signals being fed into and out of the front end chip before it reaches the physical layer controller. The physical layer controller usually consists of some type of USB or Ethernet controller. Due to the ADC and DAC inside the front end being extremely fast in the MHz of conversion speeds, there is a ton of data that needs to be fed between the baseband processing service (usually a computer) and the software defined radio itself. Ethernet and USB3.0 speeds are appropriate for the amount of data that needs to flow bidirectionally between the two devices.

FUNCTIONAL BLOCK DIAGRAM

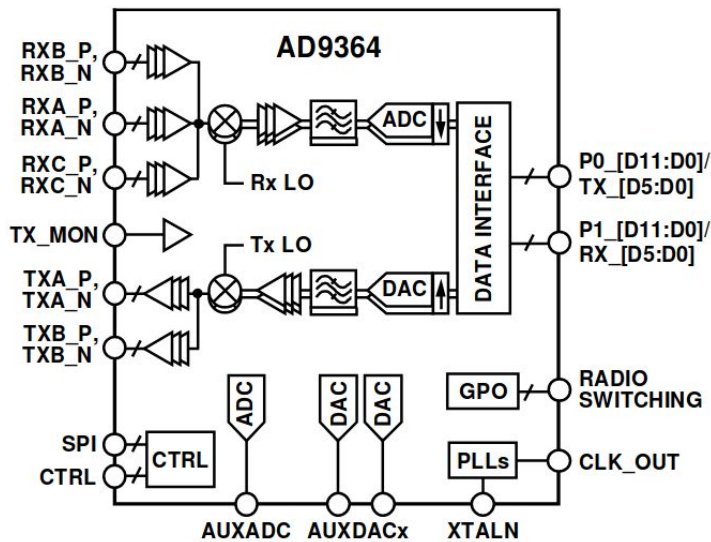

NOTES

1. SPI, CTRL, P0_[D11:D0]/TX_[D5:D0], P1_[D11:D0]/RX_[D5:D0], AND RADIO SWITCHING CONTAIN MULTIPLE PINS.

Figure 5: AD9364 functional diagram taken from the Analog Devices Datasheet. This is a typical RF front end that shows the main blocks of the architecture. Other manufacturers have similar architecture with different performance.

Gnuradio as Baseband Processor

Gnuradio is one of many open source baseband processing softwares for control and processing of software defined radios. It's success relies around it's easy to use graphical interface coupled with support for high end software defined radios from Ettus Research. Gnuradio offers a plethora of processing blocks that are easily connected. This allows you to create a baseband processing program with very little effort, besides tuning the individual parameters. Some examples of processing blocks that are useful for this project are low pass filter, high pass filter, AM demodulator, and differing FFT display screens.

Gnuradio runs on Mac OS, and different linux distributions. It connects to a software defined radio through ethernet, usb, and other data interfaces. Some other data interfaces include PCI and other custom solutions.

Section 2: Initial Design Considerations

To realize the system as outlined in many of the research papers, different frequency bands were looked at. This was the first step in the design process. As a licensed amateur radio operator, there are many frequency bands open for experimentation. The harmonic radar system would have to operate in the gigahertz or above region as this makes the physical aspect of the tag smaller. Since most tag designs are half wavelength dipoles, using a high

microwave frequency allows the tag to be compact which was a design consideration. Originally in the project the 2.4 GHz ISM band was targeted as the fundamental frequency for the radar system. One of the considerations was what available parts there are. Since the 2.4 GHz band is ubiquitous and in many products, 2.4 GHz amplifiers and other radio frequency blocks should be available. This later proved untrue and the 5.8 GHz ISM band was considered. One of the issues was the harmonic frequency and the receiving apparatus. Designing a multi-GHz receiver was out of the scope of this project. If the frequency was not covered by a software defined radio, it would not be possible to create the receiver in the fourteen week time period that would have all the performance needed for a harmonic radar system.

The search for available parts for cheap also was another design consideration that played a massive factor in the creation of the full system. As an engineering student with a limited budget the parts had to be come by cheap. eBay was used for part search and other standard microwave components manufacturers were scoured such as Minicircuits, Pasternack, and the like. A realization that helped pick the operating frequency of the harmonic radar system was the commercial satellite low noise block downconverters. These downconverters are used to listen to satellite feeds and have extremely low noise and high gain, this sounded perfect for a harmonic radar tag. Above the harmonic conversion efficiency is extremely low, so high transmit power and high receive gain is needed. These were two other factors to consider in the system design. Eventually an eBay search for satellite LNB's led to a few popular styles and frequency ranges. There were C-Band, Ku-Band, and Ka-Band LNBs. I knew from researching software defined radios that many are not capable of receive or transmit above 6 GHz. This is due the fact that only a few RF front end manufacturers such as lime microsystems and analog devices do not produce front ends that have frequency ranges higher than this. Lime microsystems have a front end that goes to 12 GHz but it is in the "to be announced" status. This limitation of the SDR platform limited the transmit frequency to a max of 6 GHz without the use of some type of upconverter. I did not want to go down the path of using an upconverter to keep system complexity down. This limits the max harmonic to 12 GHz. I came to the realization that the 5.8GHz ISM band is also part of an amateur radio band, this allows me to use a higher power level than allowed by typical ISM band users. Even though I would not transmit this system outside of a well shielded building as to not create any interference. I started looking for different components to use at this frequency. This also puts the second harmonic at 11.6GHz which just happens to be near the Ku-Band. This was a major realization that proved to be very helpful in deciding on parts. Ku-Band LNB's are very common on eBay for cheap.

Frequency Decision

The discussion above outlines the process in which the frequency range was selected. It was eventually settled on 5.875 Ghz for the fundamental and the second harmonic at 11.75GHz. The next step was researching exactly which parts to use. This proved to be easy for some components and very difficult for others.

SDR Decision

I looked at many different software defined radios, such as the analog devices pluto, the ettus research b2xx series, the ettus research x2xx series, the ettus research n2xx series, the great scott gadgets hackrf, and the nuand bladerf. Eventually after considering the costs of all of these different options and their performance metrics which I will not go into much detail. I settled on the b210mini. This SDR is the size of a credit card and utilized the AD9364 front end chip (which also covers up to 6 GHz on transmit and receive). It has full duplex transmit and receive paths which is important for the harmonic radar system relies on contiguous transmit and receive paths. Its cost is also lower than some of the other options while also being supported fully in gnuradio. Some of the options here costs as much as the entire project costs and have performance way over what was needed with multiple receive and transmit paths that are full duplex. I wanted to keep the system simple so opted for a lower cost SDR that had the ability to cover 6 GHz with multiple MHz of receive and transmit bandwidth. That is a function of the speed of the interface to the computer. The B210 uses USB3.0 with a maximum bandwidth of 5 Gbps. This allows for tons of samples to be transmitted between the computer and the radio hardware.

LNB Decision

Since the Ku band was chosen for the second harmonic frequency a LNB had to be found that was appropriate for the system. The Ku band ranges from 11.7 Ghz to 12.7 Ghz on the downlink and 14 Ghz to 14.5Ghz on the uplink frequencies. Since LNB's are meant for receiving on a ground station it covers the second harmonic frequencies perfectly. As stated before LNB's consist of a Lowpass Filter, Mixer, Local Oscillator, and Gain Stages. A suitable LNB from Orbital research was found on eBay and bought. This LNB covered 11.7 GHz to 12.2 GHz with 65 dB of gain and a noise figure at room temperature of 0.6 dB. The Local Oscillator frequency was 10.75 GHz and it uses an external clock reference. Also it had a N connector output and a WR-75 waveguide flange. The part number for this LNB was Orbital Distributing 5400XAN by Orbital Research.

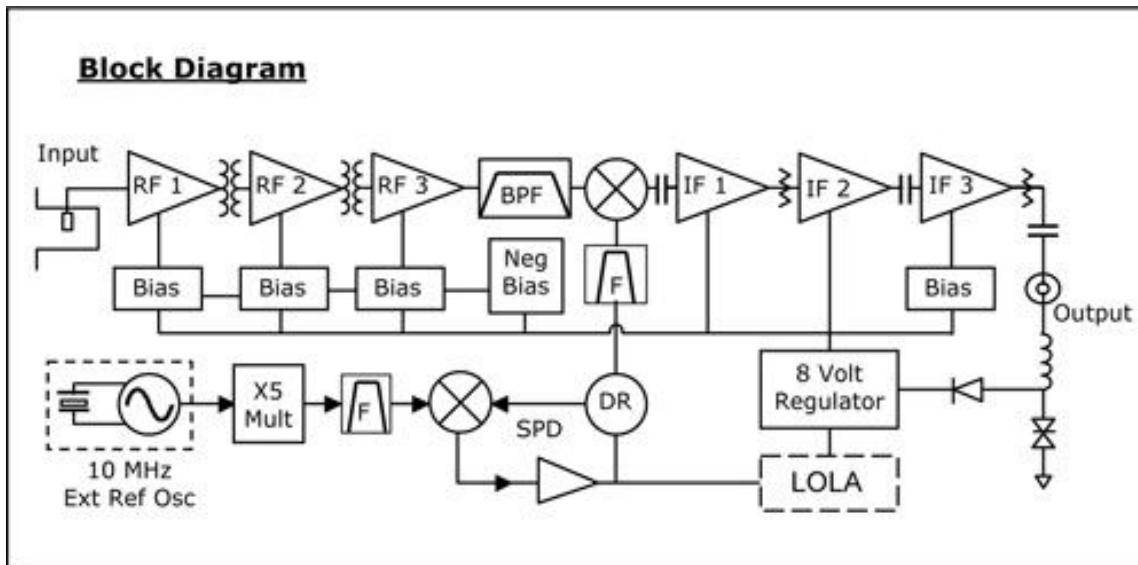

Figure 6: The specific LNB downconverter block diagram. Note the internal voltage regulator and 10MHz referenced phase locked loop. This internal PLL will be important for locking the system to a stable frequency reference for having no frequency difference between the SDR and the LNB. Block diagram taken from component datasheet.

Antenna Decision

5.875GHz Antenna

The fundamental frequency antenna was an easy decision since I already had a metal vivaldi antenna from RFspace in my junkbox. The model was a UWB-4 that covered 1.5-6 GHz with 10-15 dBi of gain and VSWR of 1.5:1 or less. Vivaldi antennas have a unique shape that cannot be mistaken with other types of antennas, they also have very wide bandwidths. A sample RFspace vivaldi is in Figure 7. The UWB-4 covered the frequency needed with a good power handling of 10 watts.

11.75GHz Antenna

This was one of the more difficult procurements of this project that ended up not being a problem at all. Since the LNB has a waveguide flange with a specified WR-75 flange an antenna was needed to mount to this. Pyramidal horn antennas are common for waveguide openings and this was sought after. An antenna with some nominal gain was also wanted to help the conversion loss of the tag be diminished by the receive system. Looking at microwave component suppliers and eBay a suitable antenna could not be found. I resorted to looking at 3d printing a horn antenna, and realized that without a powdered metal printer or some way of metalizing a plastic print, it would not be possible to achieve a pyramidal horn antenna. A chinese microwave component supplier was found and a quote was issues for a 25 dBi waveguide horn antenna. The quote came in at one third the price of similar domestic suppliers. As a last resort, Professor Makarov was asked if he had such a horn antenna and his lab was surveyed. A suitable antenna was found by ATM. The P/N for this antenna was 75-441-6. It had

a frequency range of 10-15 GHz, which is suitable for WR-75 waveguide and had the proper WR-75 flange. The pyramidal horn also had 15dBi gain. A picture of the horn is below in figure 7.



Figure 7: Pyramidal Horn Antenna on loan from WPI Professor Makarov. It came with a SMA to WR-75 waveguide adapter.

Amplifier

Due to the extremely low conversion efficiency predicted of the harmonic radar tag, a high power amplifier was needed. Since the decision was to use the 5.8GHz ISM band a suitable amplifier was needed. eBay was searched and a 2 watt 5.8GHz amplifier was found for drone video purposes. It claimed to be a linear amplifier. The amplifier was received and was found to not work exactly as promised in the ad for it.

The first test was the amplifier as is from the seller on eBay. I opened the amplifier package and did a quick reverse engineer on the stages of the amplifier to get a better understanding of what was going on.

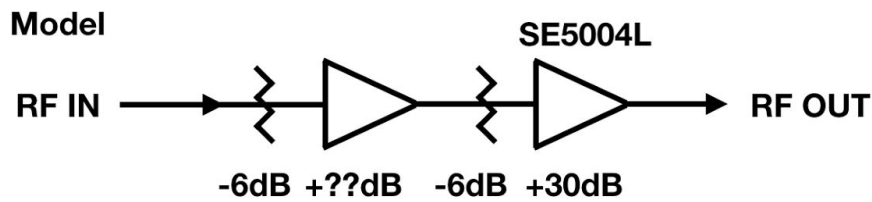
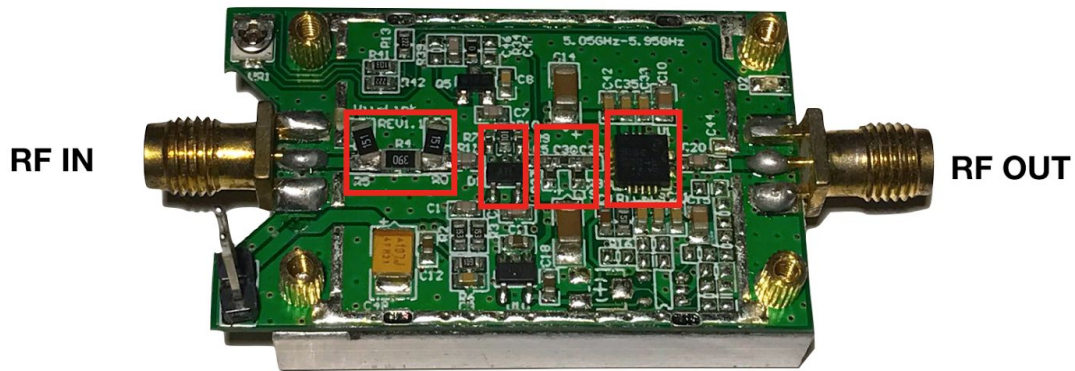

Figure 8: The reverse engineered stages of the eBay RF amplifier. Note the red blocks around the stages, and the model below that shows the RF system flow.

The eBay ad listed the total gain at 5.8 GHz to be between +6 dB and +11 dB. This amplifier measured 10 dB gain. The following graph is a sweep of the amplifier on a vector network analyzer to better understand the total gain. The sweep is a S21 log magnitude sweep. S21 refers to the detector port and the stimulus port.

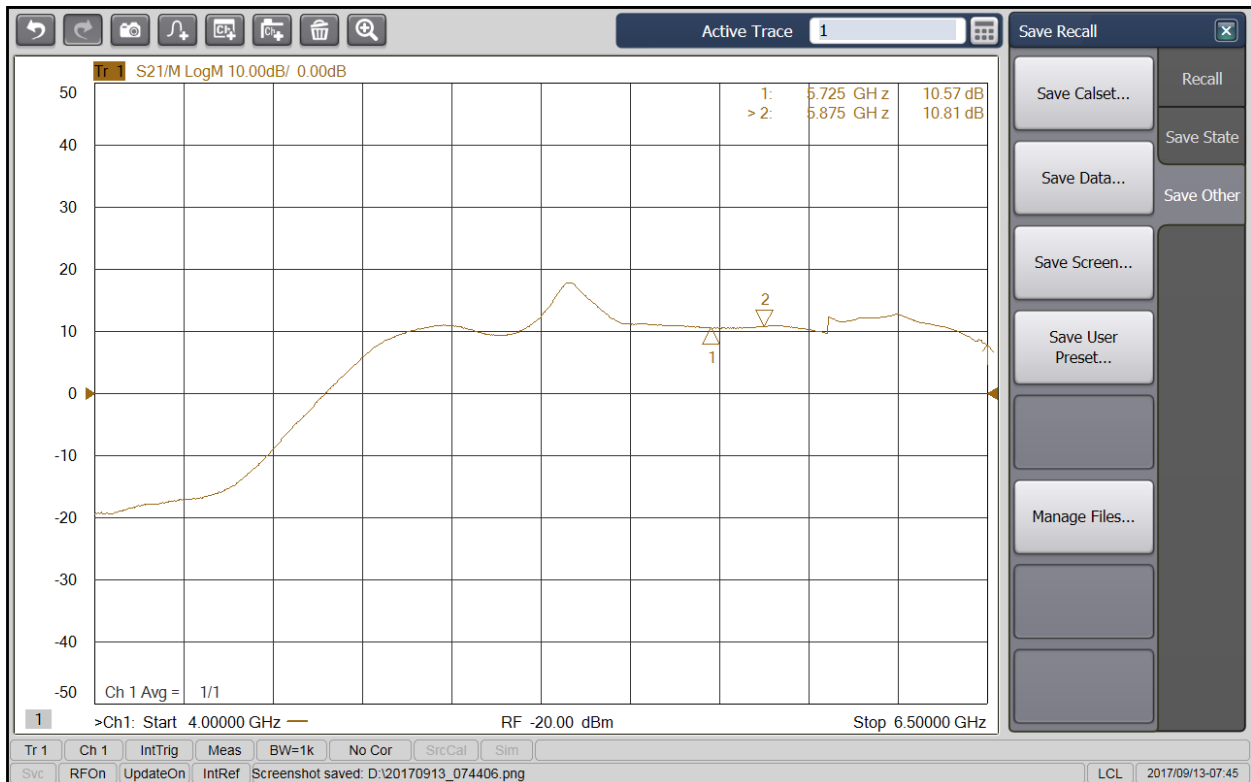

Figure 9: Unmodified amplifier swept (S21) from 4 GHz to 6.5 GHz. Note the markers are 5.725 GHz and 5.875 GHz, 10.57 dB and 10.81 dB respectively.

Due to the fact the SDR does not have a high output power, there needs to be a lot of gain to get to the high output power needed for the transmit chain. This amplifier as is would not work. I modified the amplifier to get rid of its two attenuator stages and the single gain stage. I then researched the final power amplifier (PA) chip. The chip was the SE5004L from skyworks. This chip offers ~34 dBm at the 1 dB compression point with no modulation. Since my system will not use any modulation the PA could give me ~2 watts to work with. Figure 10 shows the amplifier with its modified stages to remove what I did not need.

replace unwanted stages with micro-coax

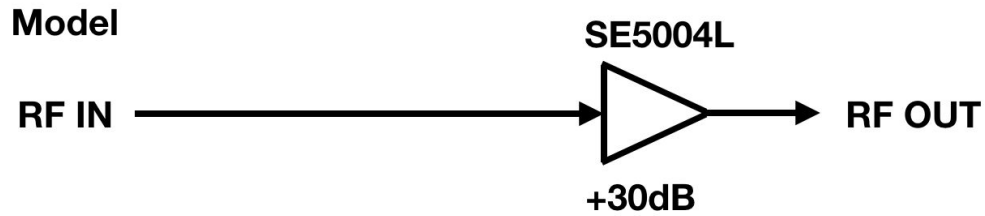
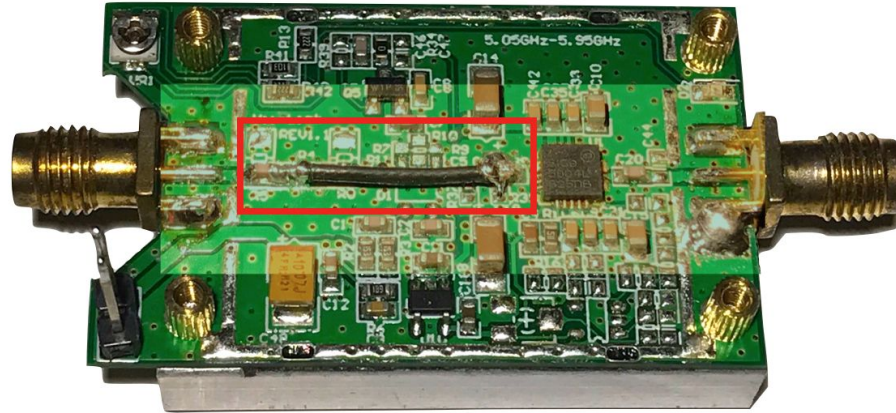

Figure 10: Modified eBay RF amplifier to only use the final Skyworks Power Amplifier. Note the micro coax running from the input connector to the input of the amplifier QFN chip.

At this point the amplifier was ready for testing with the vector network analyzer to see how the SE5004L performed by itself. In the following figure a frequency sweep of the amp (S21) was taken to better understand the modifications made. The gain was ~29 to 33 dB in figure 11 over the same frequency range as taken before in figure 9 where it was ~10 dB.

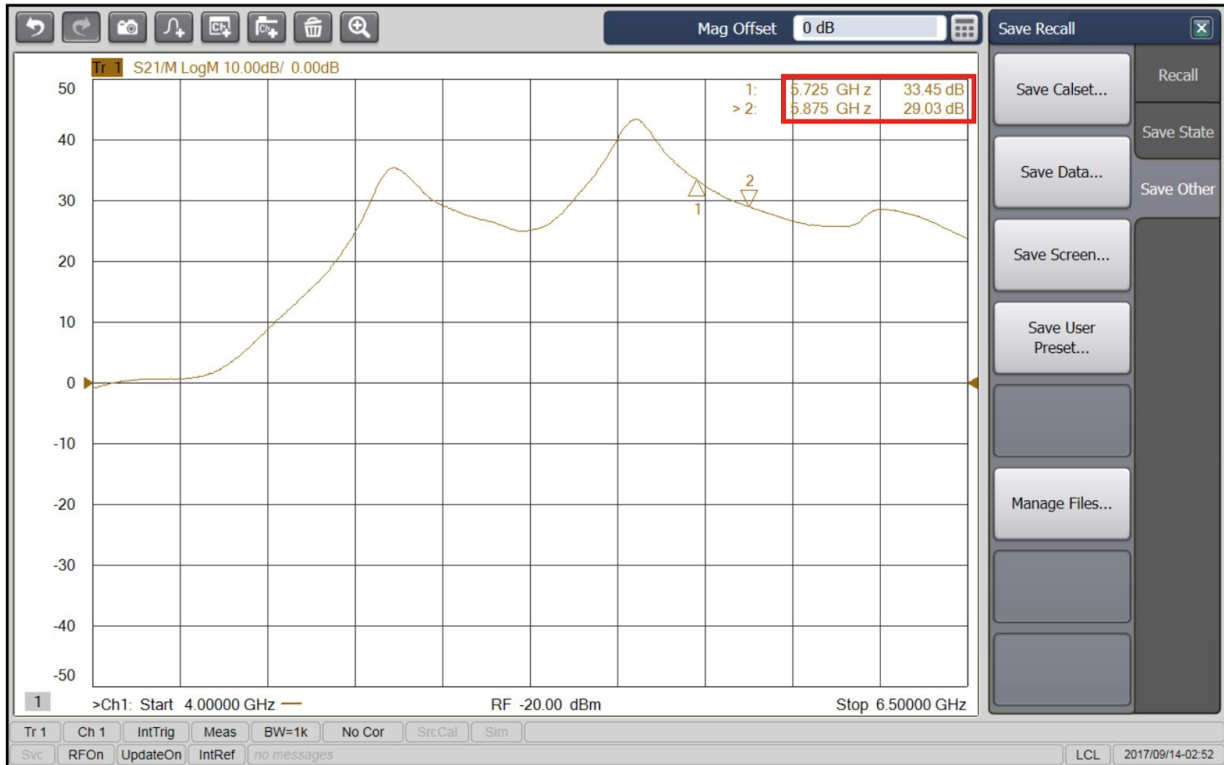

Figure 11: The modified amplifier swept (S21) from 4 GHz to 6.5 GHz showing the modification of stage removal and overall gain increase.

Now that the gain was something more reasonable for the SDR, the actual output power was tested. The vector network analyzer also does power sweeps from one power level to another and records the power input vs power output characteristics. Since the amplifier can potentially produce up to 2 watts (34 dBm) an attenuator was used in the output to reduce the power the network analyzer saw. The network analyzer can only handle 1 watt (30 dBm) on its input path so the 2 watts needed attenuation. The following figure 12 shows this power sweep in the S21 path.



Figure 12: S21 power sweep of the modified amplifier. As seen in this graph the amplifier only makes 31 dBm of power before going into its P1 dB compression point around 31.8 dBm and is no longer linear.

P _{1dB}	Output 1dB compression point	No modulation	30	34	-	dBm
S ₂₁	Small Signal Gain	P _{IN} = -25 dBm	30	32	-	dB

Figure 13: Datasheet values for P1dB and small signal gain.

Figure 13 shows the P1dB as somewhere between 30 and 34 dBm which indicates the amplifier is doing exactly what it is specified to do. This is unfortunate because my specific amplifier does not put out 2 watts. As I did more testing with this amplifier I realized that in a no modulation continuous wave signal amplification mode, which models the future radar system, the amplifier dissipates a lot of heat. RF amplifiers are usually very linear and burn a lot of power to create this linearity and frequency range. This amplifier as it heats up has internal protection that lowers the gain as the die heats. Unfortunately the board design does not thermally connect the QFN thermal pad to the heatsink with an appropriate thermal resistance. This makes the die unnecessarily hot and the power starts to be folded back in protection. A way to solve this would be to increase the number of thermal vias to the QFN pad on the bottom of the package. This would require a new board to be made. Due to the timing of this project, this amplifier was scrapped due to this issue.

A new amplifier had to be found, so the search back to eBay was continued. I was looking for the same type of linear power amplifier with multi-watt output power and the same frequency

range. I stumbled upon amplifiers that were pulled from a larger assembly by Terrasat. A few amateur radio operators use these amplifiers on the 5.7 GHz amateur radio band. I found an amplifier that stated it worked on 5.875 GHz, the exact frequency I would later be using. One eBay ad explained the power supply pinout on the connectors from the amplifier module. The amplifier required 12, 8, 5.5, and -12 volts. This would require a semi-complicated power supply to be built. I aimed to use all linear regulators due to the fact any noise from a switching converter would cause phase noise or output spurts, the exact things I do not want in my output signal.

A basic block diagram below is provided of the power supply. One of the design constraints was that I wanted linear regulation, and to have one input power source of 12.5-15 volts. My entire project would be powered on 13.8 volts due to being a common voltage in my lab.

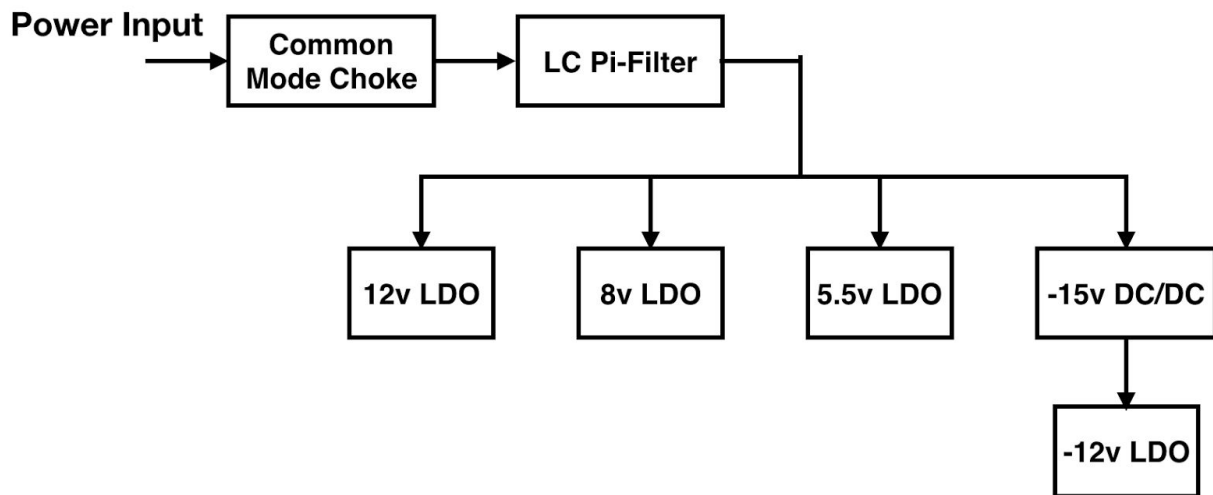

Figure 14: The power supply for the amplifier. This was a single input multiple rail output power supply. An input common mode choke and LC Pi-Filter was used to clean up and bypass the input power to the regulators. The 12, 8, and 5.5 volt regulators were Microchip MIC29503WT positive linear adjustable regulators that support up to 5 amps. The -15v dc/dc converter was used to generate the negative rail from the positive power input and then cleaned up with a -12 volt linear based regulator for high power supply rejection of the dc/dc converter switching frequency. The -15 volt dc/dc converter is a CUI VXO78015-1000. This is a positive 15v switching regulator that also can be configured for a non isolated negative output. The regulator supports 1 amp positive and 330 milliamp negative. The linear regulator following this dc/dc converter was a 7912, a basic -12 volt linear regulator with one amp of output current. The amplifier itself does not draw much current from the -12 volt rail and is below the current ratings of the two regulators combined.

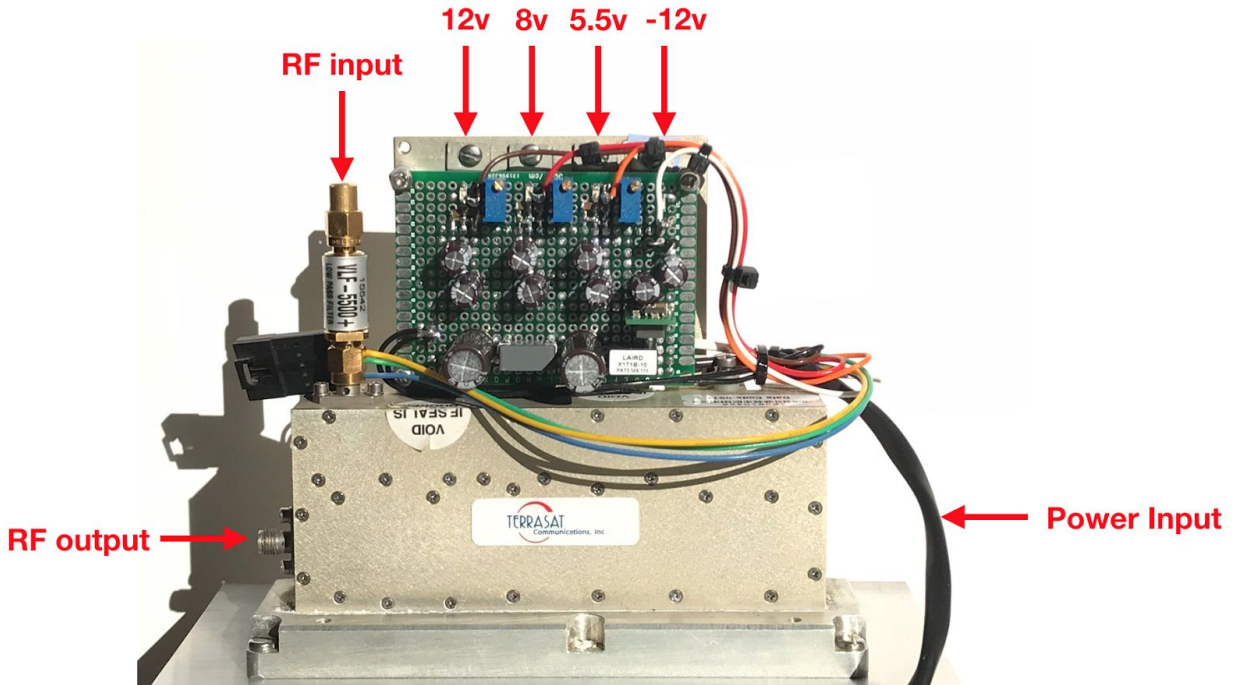

Figure 15: An overall view of the Terrasat amplifier on its custom heatsink with custom made power supply board mounted to the amplifier heat spreader back plate. Note the single cable input power and the RF Input/Output connections.

One of the last tests to run with the Terrasat amplifier was to look at its harmonic response and characterize its output power. A test was set up to look at the harmonic response on a spectrum analyzer and a signal generator was used as the input RF source

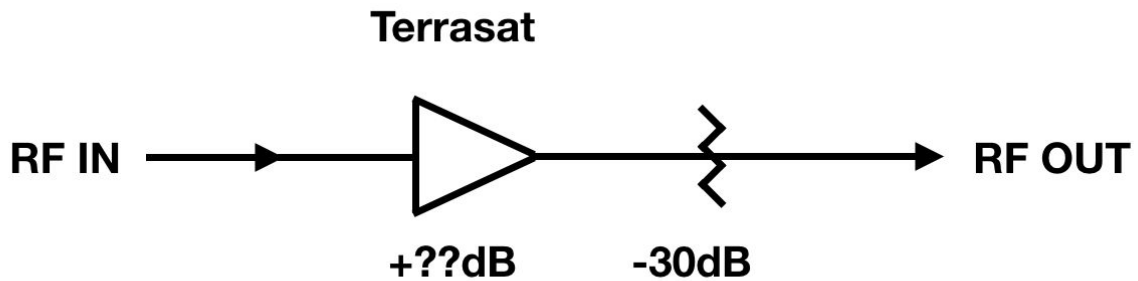

Figure 16: Test setup for harmonic generation analysis. The RF input was provided by a signal generator and the RF output was connected a spectrum analyzer. Note the 30 db attenuator in line with the output to reduce the input power seen by the spectrum analyzer. This is good practice and necessary because the spectrum analyzer cannot handle the power generated by the amplifier on its input. The amplifier was measured with a gain around 50 dB. This means that the drive level of the amplifier needs to be 50 dB below the 36 dBm output or around -14 dBm.

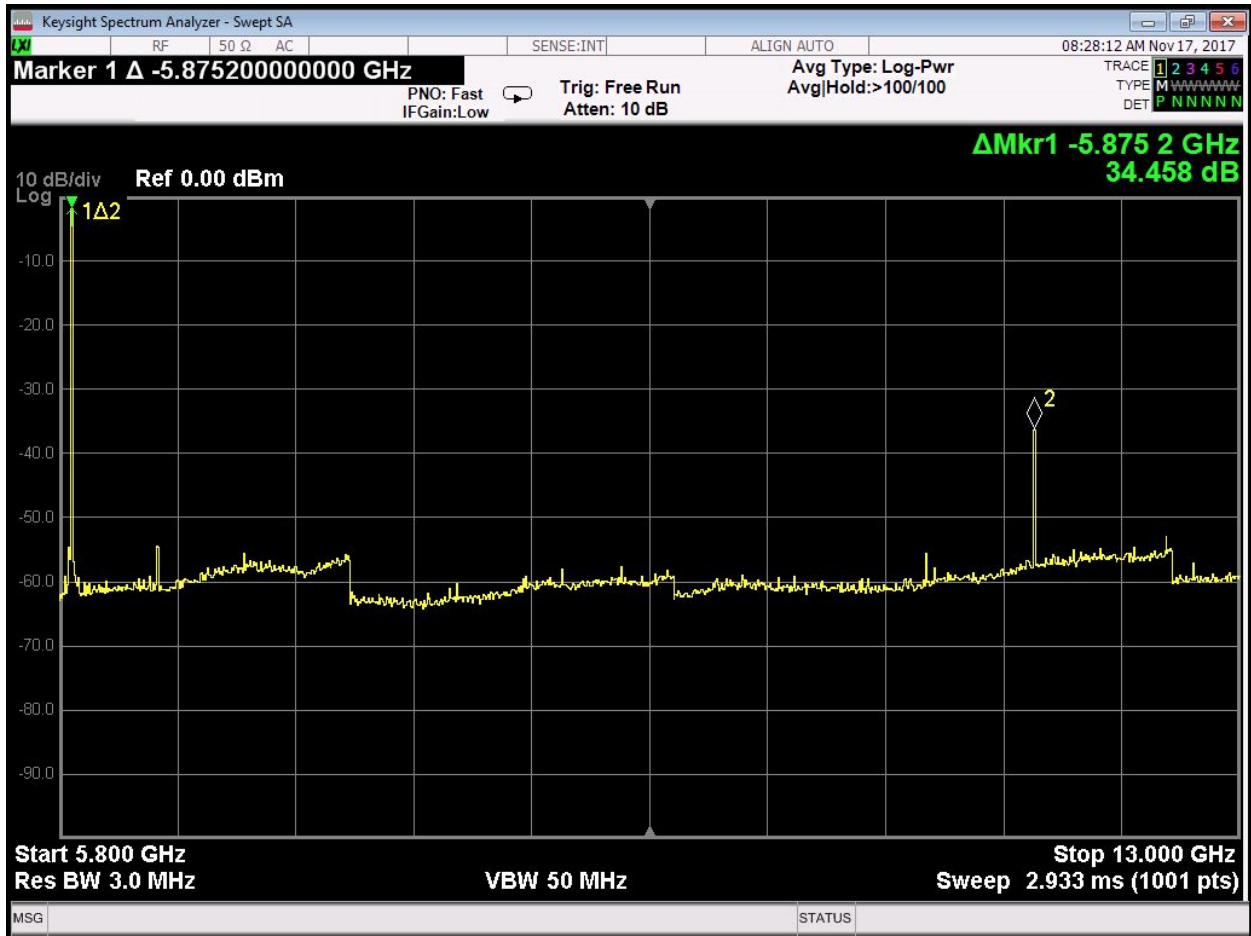

Figure 17: An averaged sweep to reduce noise seen of the Fundamental output at 5.875 GHz and the harmonic generated at 11.75 GHz. A delta marker can be seen measuring 34.458 dB of fundamental to harmonic attenuation. This is sometimes denoted as dBc or dB referenced to the carrier which would be the fundamental.

The 34.458 dBc measured was unacceptable and was a bit disappointing but this was just another problem I had to solve. I tried different input power levels incase we were driving the amplifier into saturation where harmonics could be created. I had originally purchased some lowpass filters for this exact reason when I made my initial order to mini circuits for cables and other accessories. I decided it was time to break out my 6 GHz low pass filter from mini circuits part number VLF-5500+. It has a 3 dB point of about 6 GHz and I will be operating at 5.875 GHz so the filter will have some loss. Figure 18 shows the improvement this filter made on the output of the amplifier.

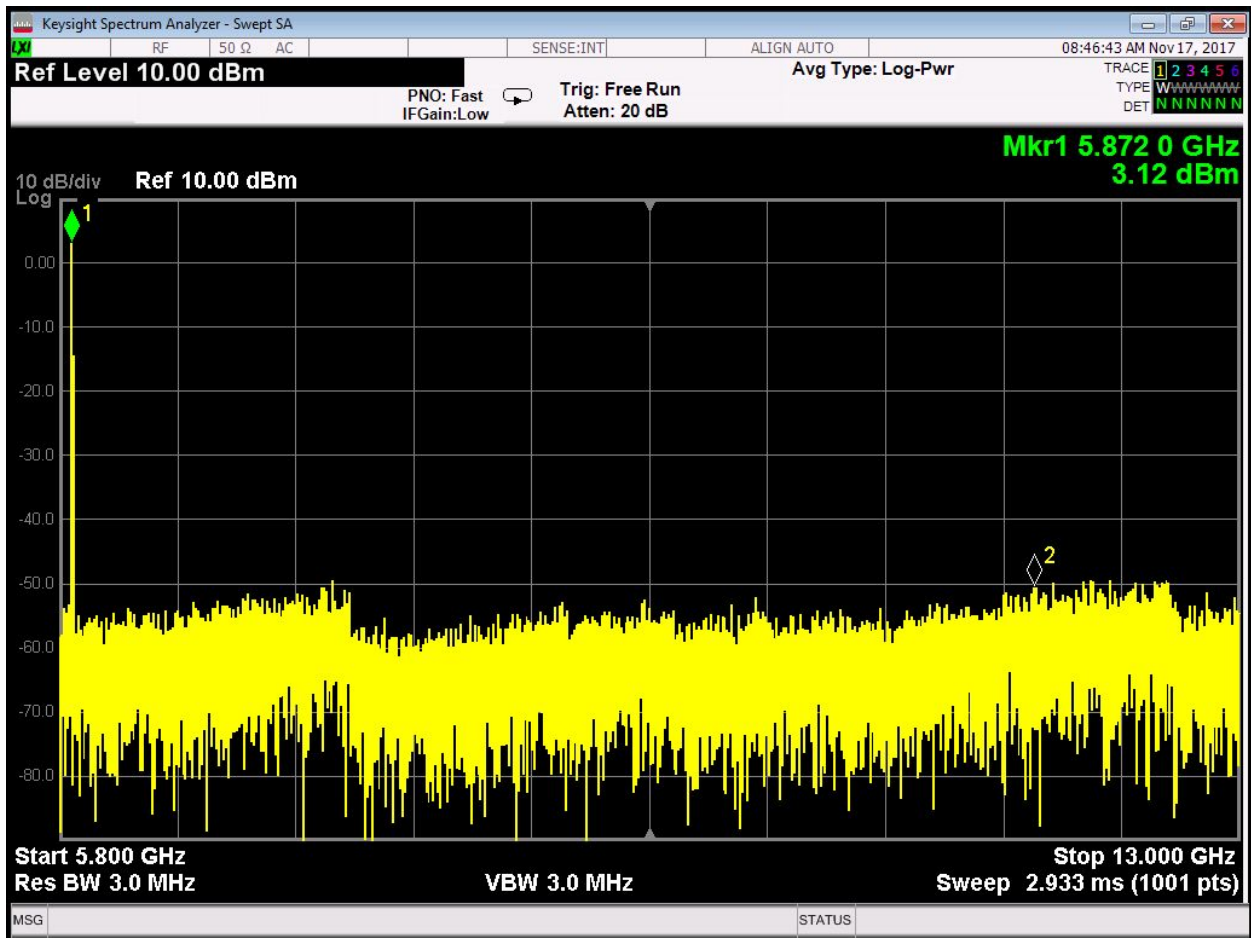

Figure 18: This sweep did not have averaging on and the noise is much more visible than Figure 17. Note the improved harmonic rejection. Delta markers did not make sense here since there is no discernable harmonic generated at 11.75 GHz. Note

It was extremely promising that the harmonic was completely eliminated by this filter, the main issue now was that the filter was absorbing ~2 dB of power which is almost 2 watts. This was not promising but moving the filter to the input side of the amplifier had the same benefit without burning 2 watts of wasted power. On the input side you can increase the RF drive level to compensate for filter loss and still achieve the full 4 watt, 36 dBm output power.

This concludes the parts selection discussion and in the next section we will look at the radar system built and the software designed.

Section 3: Methodology

I wanted to create a rack chassis for the software defined radio and other assorted support pieces for the radio itself. This would allow me in the future to use this as a RF block in projects. I decided on a 1u rack chassis from eBay made of aluminum. I designed a layout for the front panel and internal chassis and built it. The chassis includes a USB 3.0 hub so that cable length is not a factor in the performance of the data transfer from the SDR to the computer. The hub also has a usb flash drive connected for local file storage for some documents of how to setup

the SDR and other miscellaneous help files. The chassis then includes a 10MHz ovenized reference crystal oscillator as a master clock that will provide an output to other equipment that needs to be referenced. The master clock has an input to reference the 10MHz oscillator to another source this can be useful if this needs to be slaved from another piece of equipment's time base. The ovenized crystal oscillator needs 15 volts to run properly. This created a problem because the entire system is meant to run off 13.8 volts. A dc/dc converter was used to boost the the voltage to 24 volts and then a 7815 linear regulator was used to regulate down to 15 volts. The dc/dc converter was a Vicor VI-203-EY 12v to 24v boost converter.

The overall system block diagram is shown below with an annotated picture of the actual chassis that was built.

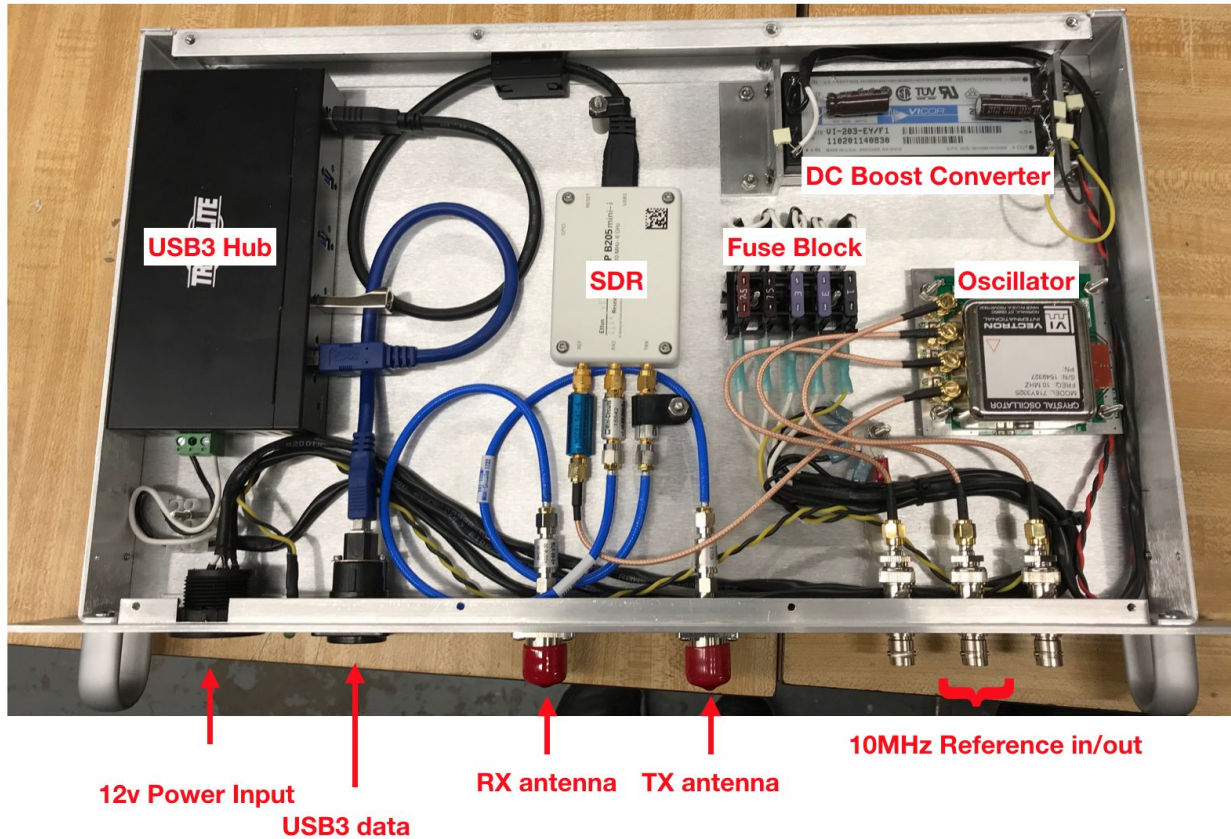

Figure 19: The actual chassis that was built with annotations for each interface connector and major blocks identified internally.

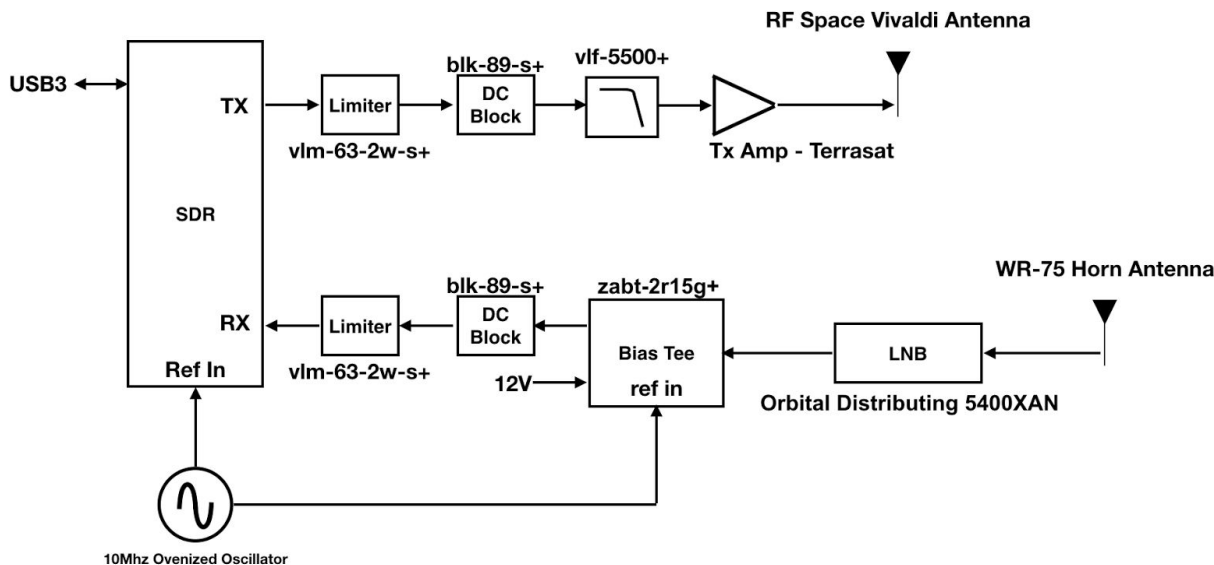

Figure 20: The overall Radar system with call outs for all component part numbers and interconnections. Note the TX and RX paths and their associated components. The final design used limiters and dc blocks as means of protecting the sensitive software defined radio chip from ESD, over power, and improper dc connections. This was done for peace of mind but is not needed.

After the hardware section of the radar was completed the software side had to be started and tested. Gnuradio was used as the baseband processing system on a linux ubuntu running computer. Gnuradio as mentioned before offers amazing flexibility and quick development cycles as you can rearrange and change parameters then click run where the software compiles your changes and loads them into the sdr and runs the software back end. This allows for very fast development of the entire system. It took roughly 10 days to get a full basic system working. The gnuradio system is designed in what is called a flowgraph. The flowgraph is a visual software environment where system blocks are interconnected and parameters can be changed. For this project only parameters and blocks were connected and changed. No new blocks were designed. The flowgraph is not limited to just signal processing but also to creating a graphical user interface that one can interact with to see data and change parameters while the software is running. Below is the final flow graph developed.

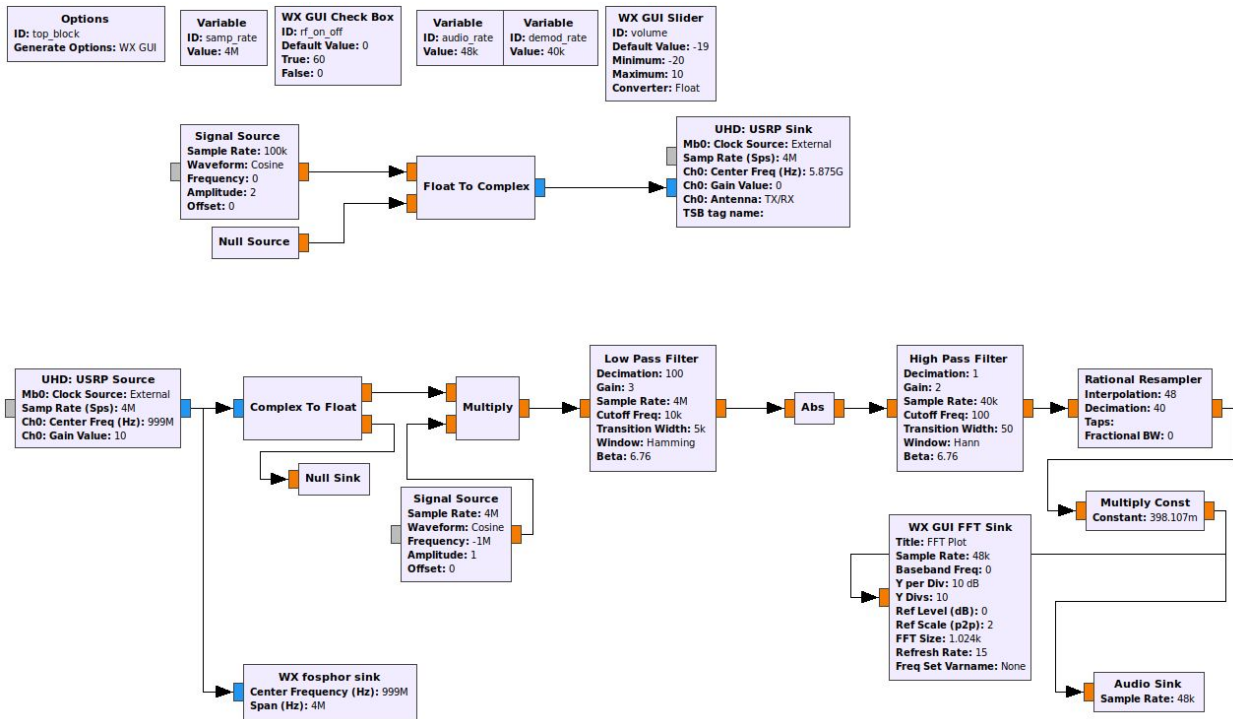

Figure 21: The final Gnuradio flowgraph developed. Note the two different signal paths, one for transmit and one for receive.

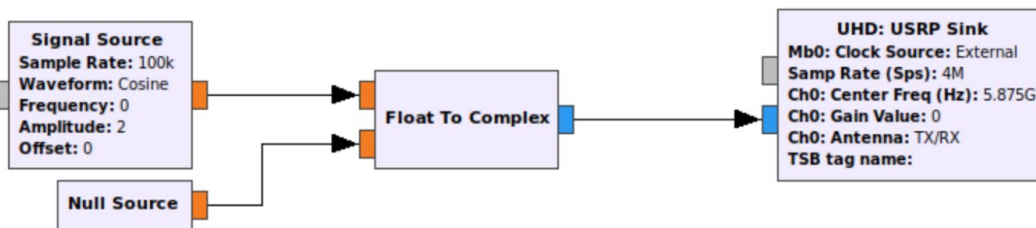

Figure 22: The transmit path zoomed in for clarity

The transmit signal path in figure 22 starts off with a signal source that's set to a 0Hz rate. This is because we are looking for just continuous wave tone out of the SDR at a specific frequency. The SDR is meant to generate signals from I/Q data and modulate those on top of a carrier frequency. Since we do not want any modulation on our CW tone, the signal source is put into a I/Q generator with the imaginary part being a null value source. This essentially tells the baseband processor that there is no incoming modulation data and to just output a CW tone at the final mixer frequency which is set in the block labeled UHD: USRP sink. The UHD: USRP sink is the endpoint for transmit data, this is where the data is piped to the baseband DAC and put into the final transmit mixer.

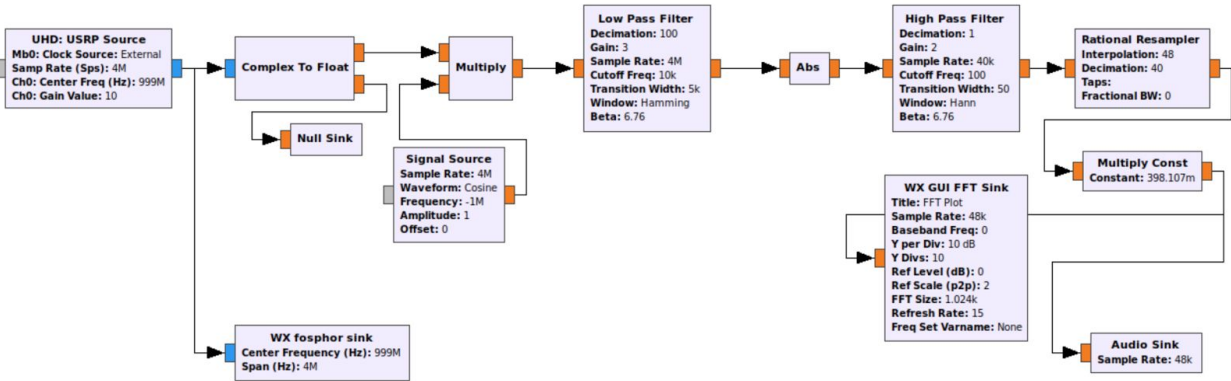

Figure 23: The receiver path zoomed in for clarity

The receive chain starts off with the UHD: USRP source, this is where all the data from the SDR comes into the gnuradio program flowgraph as IQ samples at the sample rate specified in that blocks parameters. In my system I used a sample rate of 4 megasamples per second. At a center frequency of 999 MHz. This is due to the fact that our receiving low noise block downconverter has a local oscillator frequency of 10.75GHz. Our second harmonic is at 11.75GHz and thus the difference is exactly 1 GHz. This 999 MHz signal puts our second harmonic signal in the baseband signal at 1MHz. The first thing the I/Q baseband samples goes to is the fospor sink which is a GPU (graphics processing unit) accelerated FFT. This allows the signal to be seen in the frequency vs power domain at a update rate of over 30Hz. The next part of the signal chain is taking the I/Q data and removing the imaginary part. This helps in processing as it is effectively half the number of samples to process. Since the data we are looking for is amplitude modulation you do not need the imaginary data to decode the waveform envelope. This allows a speed up in the data processing part of the flow graph. The next step is to multiply the baseband signal by 1 MHz to move the signal from an RF baseband frequency into a human hearable frequency. This effectively moves the baseband in the audio range. The next step is a low pass filter to get rid of any spurious emissions outside a certain audio range. This helps clean the audio from the noise and makes it more intelligible. The next step is to actually convert from the baseband signals which are centered in the audio frequency range into actual an actual audio signal by taking the absolute value of the signal which effectively is the envelope of the signal. This is considered an amplitude modulation detector. The last signal processing block is a high pass filter. This high pass filter removes near DC components of the audio signal that cause clipping of the signal due to DC offset. There is only a certain range of values that can represent each sample and if half of the sample is taken by a DC offset value then you are losing dynamic range among other things. DC is also bad for speakers and having to reproduce that section of the signal causes popping or driver extension. The computers audio card already is AC coupled internally so only so only ear shattering pops are stopped with the high pass filter.

The last few sections deal with syncing up the sound cards sample rate and the sample rate of the incoming data stream. The final blocks are the actual sound card sink, this is where the samples get sent to the driver to produce the actual calls to the audio system and a FFT. This FFT shows us the power versus frequency of the actual audio signal.

There were many parameters of this system both receive and transmit side to be tuned but the most important was tuning was the RF gain and signal levels of the transmit chain to reduce the harmonic generation. Reducing the RF gain reduces output power but also reduces the harmonic content to an extent when its no longer clipping peaks. The minicircuits low pass filter in front of the RF power amplifier can only do so much to reduce harmonic spur generation so tuning the system was necessary. A spectrum analyzer in WPI's RF lab was used to analyze the 11.75GHz output signal. This spectrum analyzer had sufficient bandwidth to analyze this signal. The test setup is shown below in the following graphic. Only the transmit side is shown because receive functionality was not being tested here.

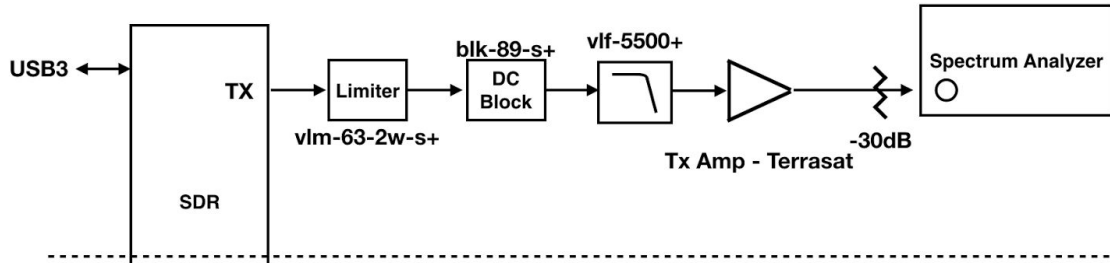

Figure 24: The test setup of the the SDR in the transmit chain. Note not all tests were run with the low pass filter unless explicitly stated.

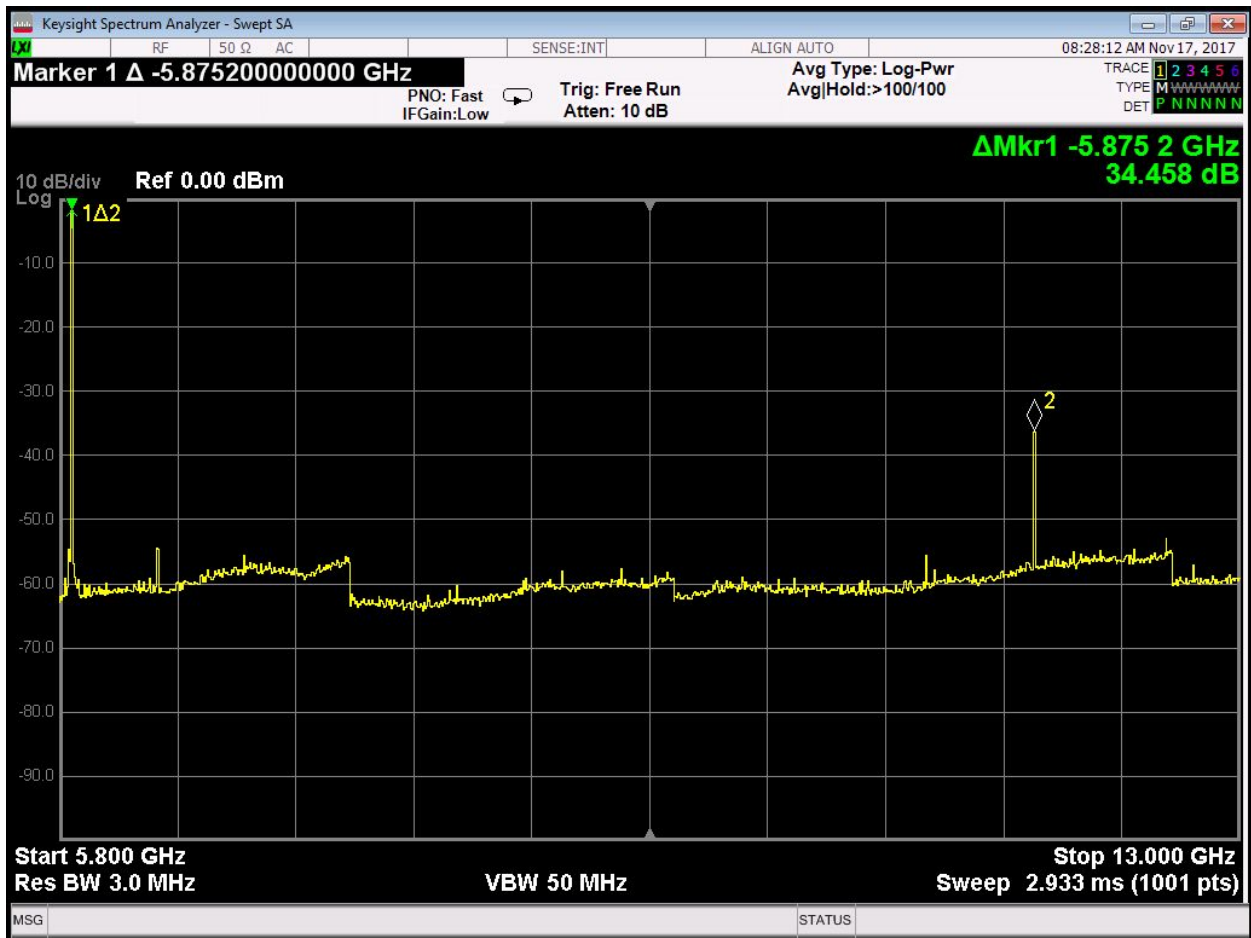

Figure 25: Harmonic dBc of ~34dB with a transmit gain of 80. This is a lot of harmonic content generation and well outside the specifications of the front end chip for this frequency range. This indicates gain can be lowered to reduce potential clipping causing this.

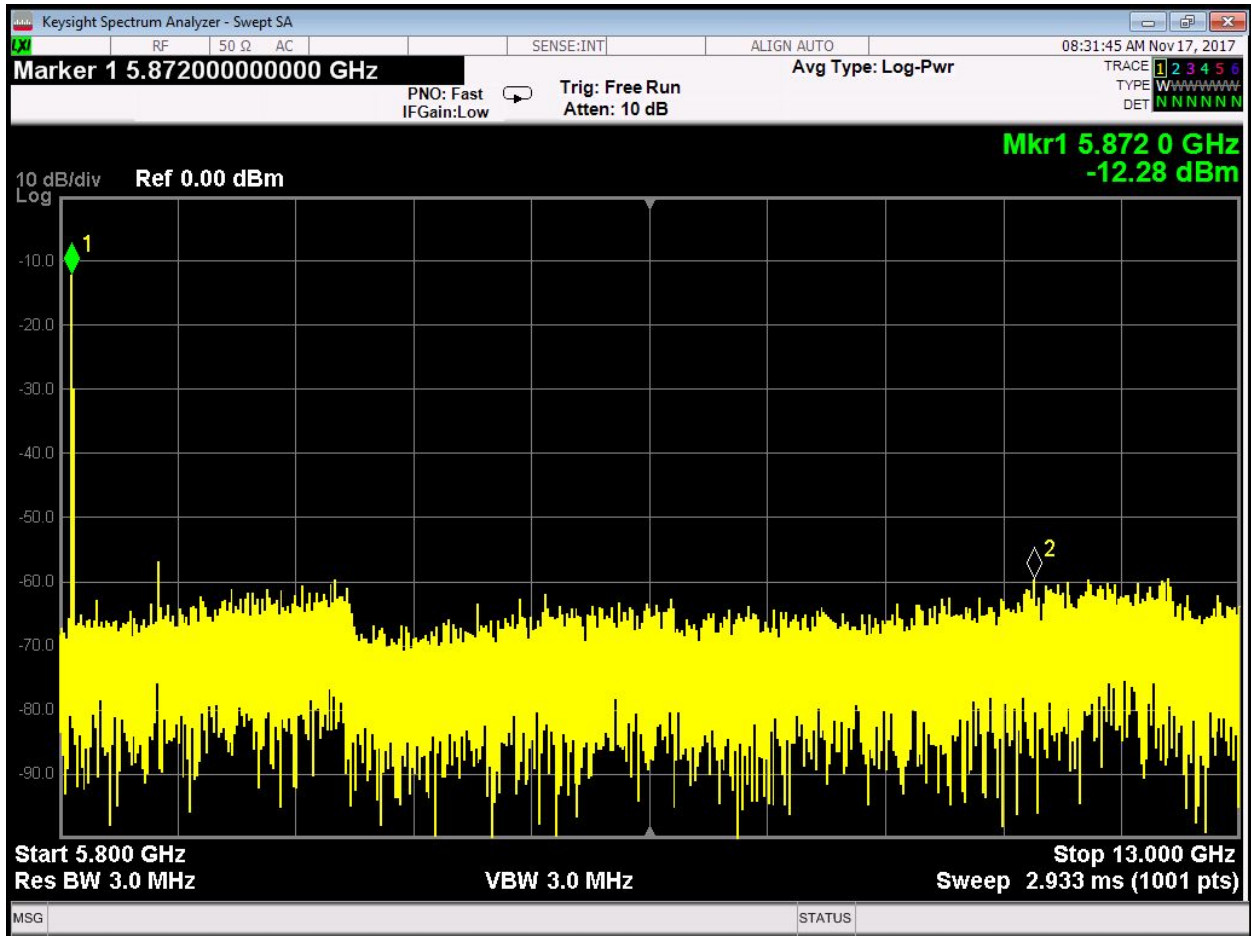

Figure 26: Harmonic dBc of ~80dB with a transmit gain of 70. This is the performance expected. Note the second marker being almost within the noise floor of the analyzer.

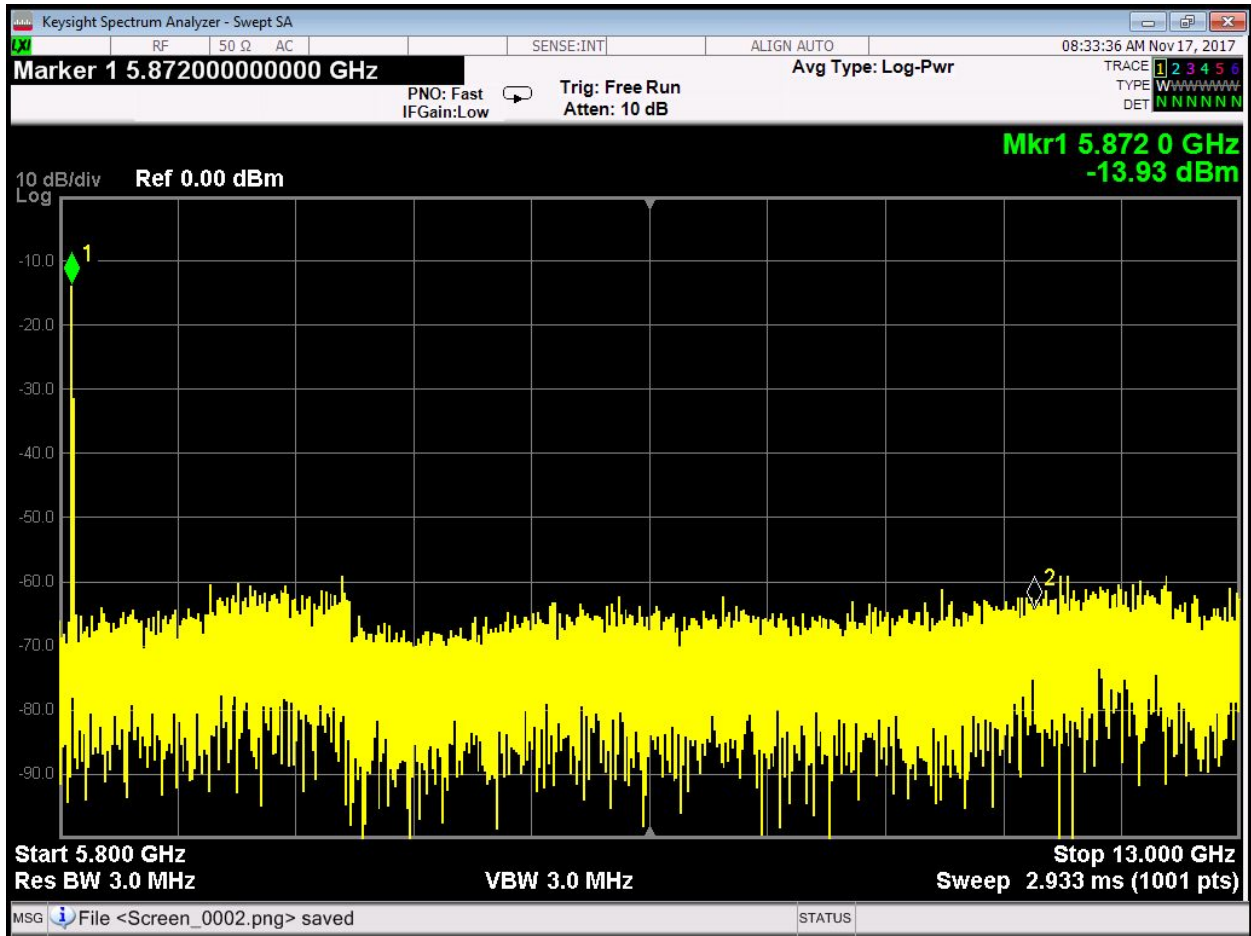

Figure 27: Harmonic content generation with the lowpass filter now inserted, note the -13.93dBm output signal power through a 30dB attenuator.

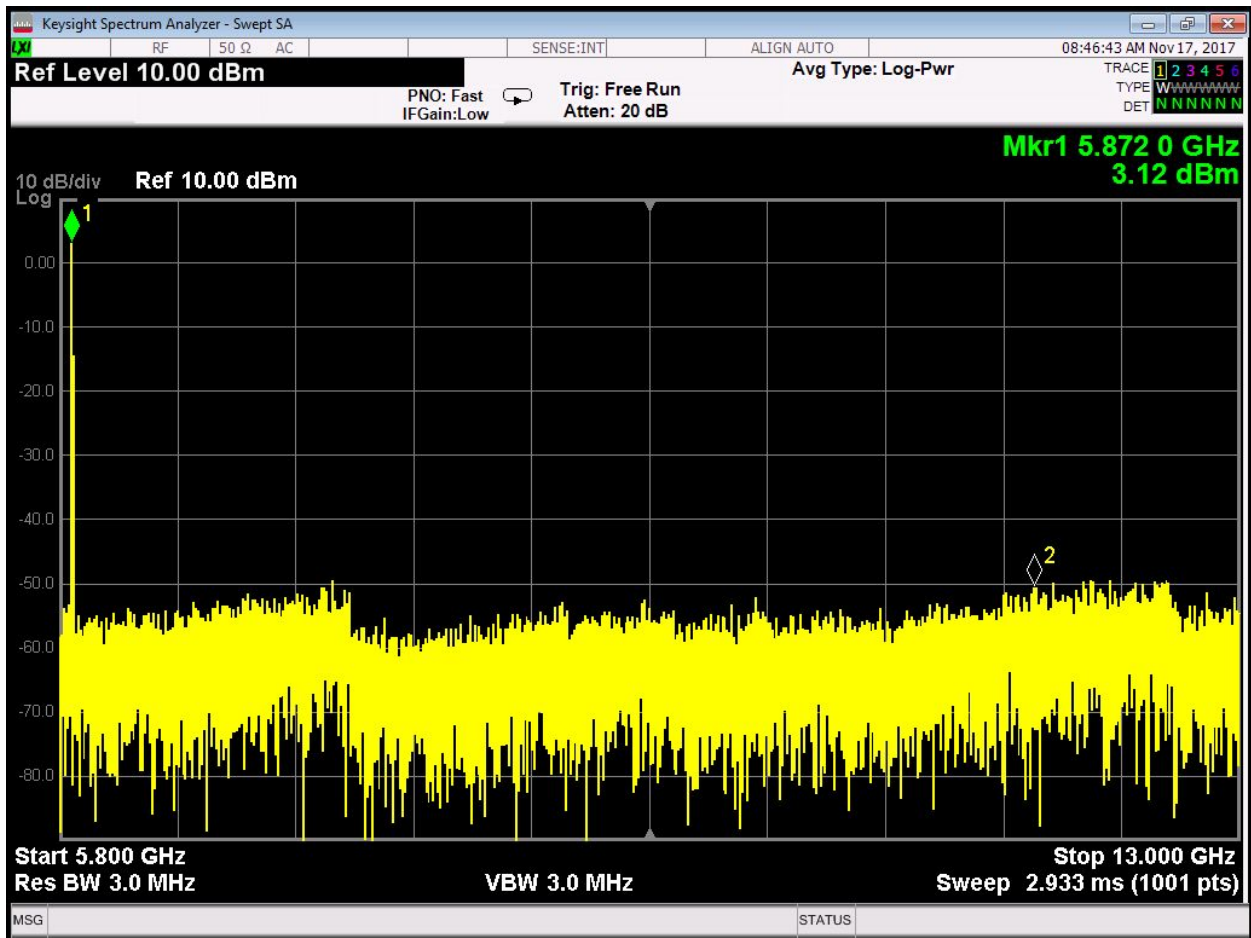

Figure 28: The final output power with all settings tuned perfectly for max power and least harmonic generation. Note that there is a 30 dB inline attenuator in front of the spectrum analyzer for protection. This indicates that there is 33.12 dBm or ~2 Watts of output power with no perceivable harmonic. This was a success of this part of the system. Although we are not hitting the 4 watts of output power the amplifier is capable of, a lossy cable will be found later in the testing and replaced to make this output power achievable.

Section 4: Tag design

The entirety of this project as to spend as much time working on designing different harmonic tags for different purposes. The main objective was to get a simple reflective harmonic tag working. This was accomplished. Harmonic tags are usually passive in nature requiring no battery power and also very simple. The initial concept tag design is shown below.

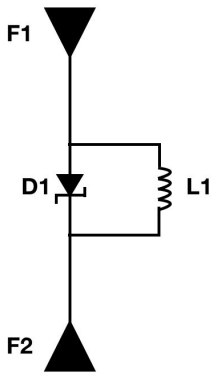

Figure 29: The initial concept tag. Note D1 and L1. These are important pieces for the harmonic content generation.

Theory of operation: A stimulus signal causes the F1+F2 dipole elements to resonate at their tuned frequencies, the diode steers charges from one side of the dipole to the other and causes an imbalance while doing so. This imbalance is a doubled frequency of the fundamental. L1 is a charge balancing inductor between the sides of the dipole. As the diode steers charges in one direction it is possible for the diode to become reversed bias where it would no longer rectify. This inductor keeps the charges balanced between the sides of the dipole.

The initial tag is based off many IEEE research reports that show a very simple dipole antenna of the fundamental frequency with a diode in between the arms. The dipoles in the reports have been half wavelength so this was the length I would aim for on my first tag design. Using the standard wavelength to frequency equation the dipole arm length was calculated to be 12mm long for 5.875GHz fundamental. I planned to leave extra length on the tag to trim it to size to see the response. One of the other parameters were the different diodes to decide upon. All the tags ended up using the first diode that I chose because its parameters were suitable and it was cheap. It was a high frequency schottky mixer diode from skyworks, part number SMS7630-079LF. The other parameter that was played with was the inductor value. The inductor of most of these harmonic reflector tags was made by looping the wire. Since the frequency is so high a simple loop of wire acts as a big enough reactance.

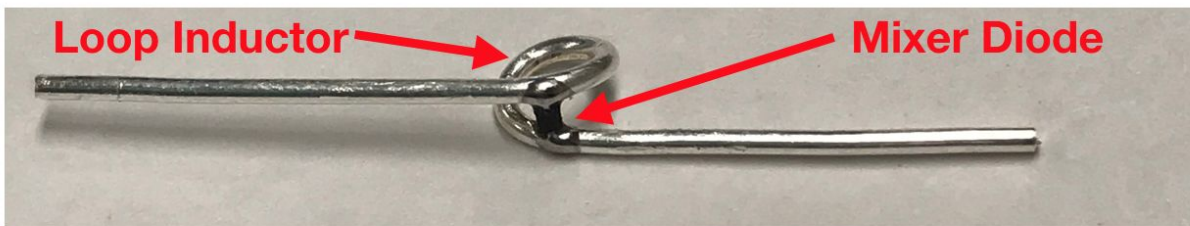

Figure 30: The first tag constructed and an example of many of the tags tried using 20 american wire gauge that is silver plated copper. The loop is formed with a diameter of 2.2millimeters and the diode soldered at the break away point from the loop.

The next idea was to create a tag that would be able to modulate a signal onto the reflected harmonic. This would either be digital data or an analog data. I had lots of ideas for applications but nothing was simpler than a simple digital data modulator and a voice modulator.

The idea for the digital tag would be to insert a transistor and modulate the gate with the digital signal. Originally my digital modulate tag was my analog modulator tag and it didn't work. The response curve of the transistor with an analog signal causes distortion as the transistor reaches its threshold on and off voltages. The transistor would need proper bias and that's outside the scope of a passive tag as it would require a battery. Testing of this tag will come later in the results section.

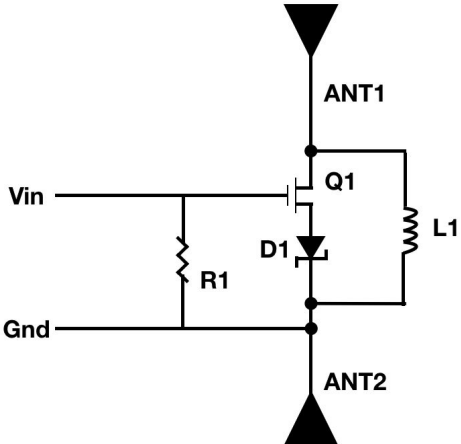

Figure 31: The schematic of the digital modulation tag. Q1 is a PHEMT high frequency transistor able to switch both the fundamental frequency and the harmonic frequency.

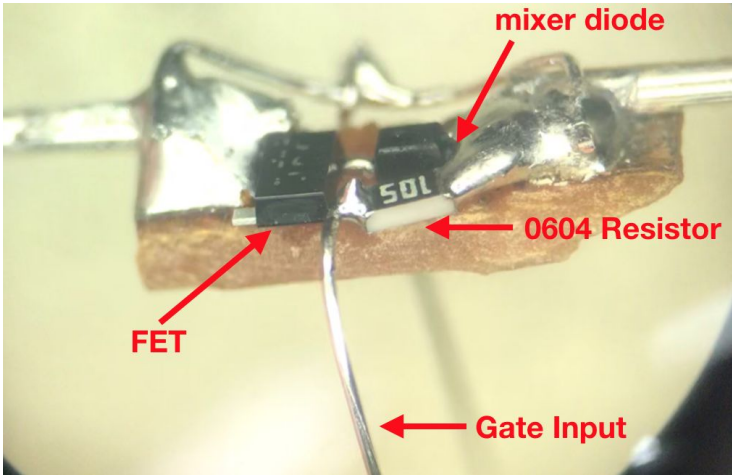

Figure 32: Digital tag under the microscope to examine all the parts. The tag was created on a piece of copper clad with point to point soldering technique.

The second tag designed was an analog tag. The tag is just a modification of the original tag with no loop inductor, the modulated signal is across the diode and causes the diode to forward and reverse bias with the envelope of the signal. This causes an increase and decrease in the

amplitude of the harmonic generation. It becomes an amplitude modulator from a pure analog signal. An analysis of the tag was done using a circuit simulator LTspice. A tag was created and then modeled within LTspice. Some of the nuance in the creation of the tag was a choke inductor that keeps the GHz radio frequency from travelling back down the analog input connections. This was achieved with very thin wire wound on a mandrel of 1.5mm diameter.

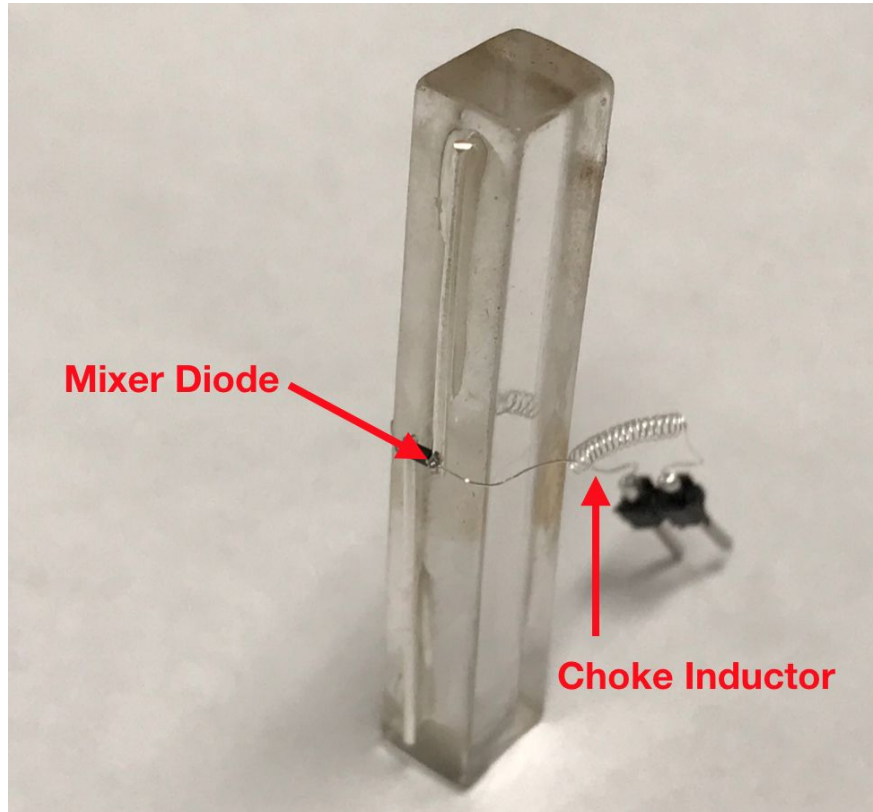

Figure 33: Analog tag in its final testing form. The two dipole wires were secured with UV cured glue onto a piece of acrylic plastic. The mixer diode was then mounted and two very small wires soldered to the connection point and made into the choke inductors. A 0.1 inch header is used for final connection to an outside analog source.

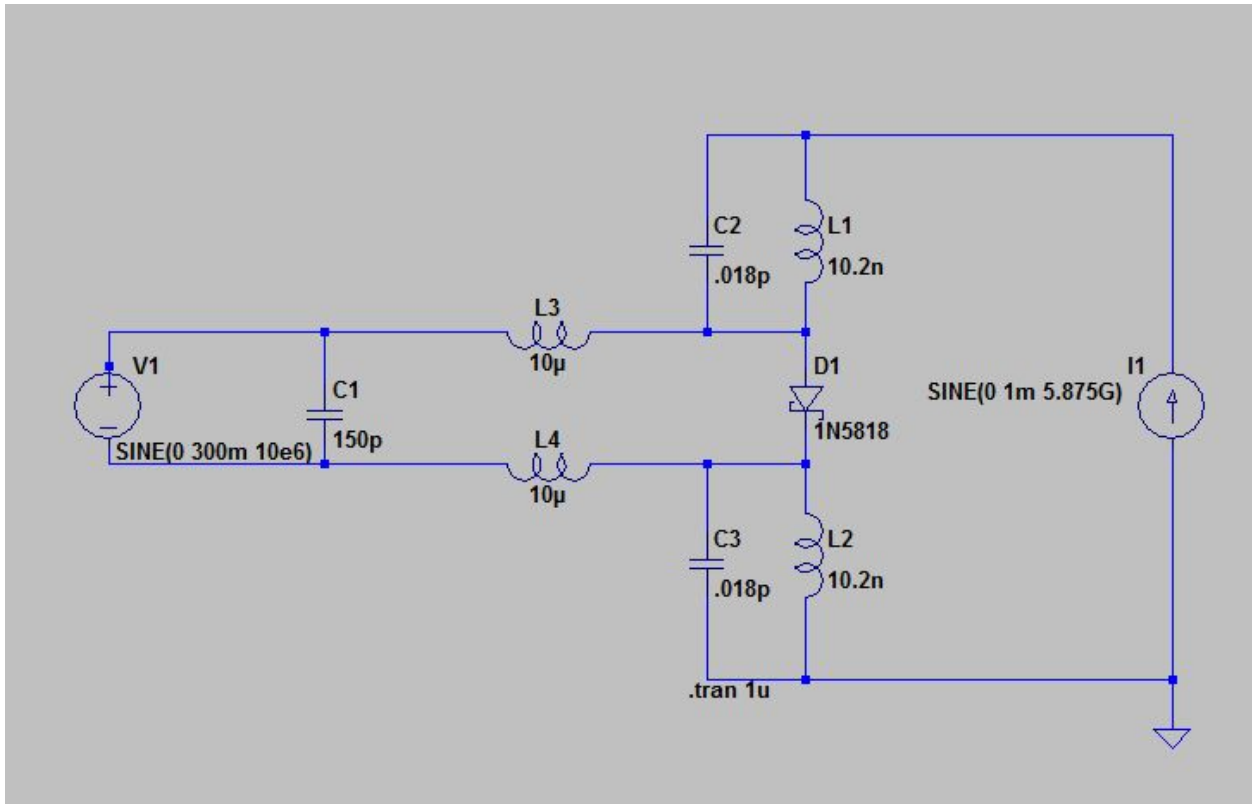

Figure 34: Schematic and Modeled tag in LTspice. This was to prove that a signal source modulating the diode through an analog component could affect the dipoles resonance.

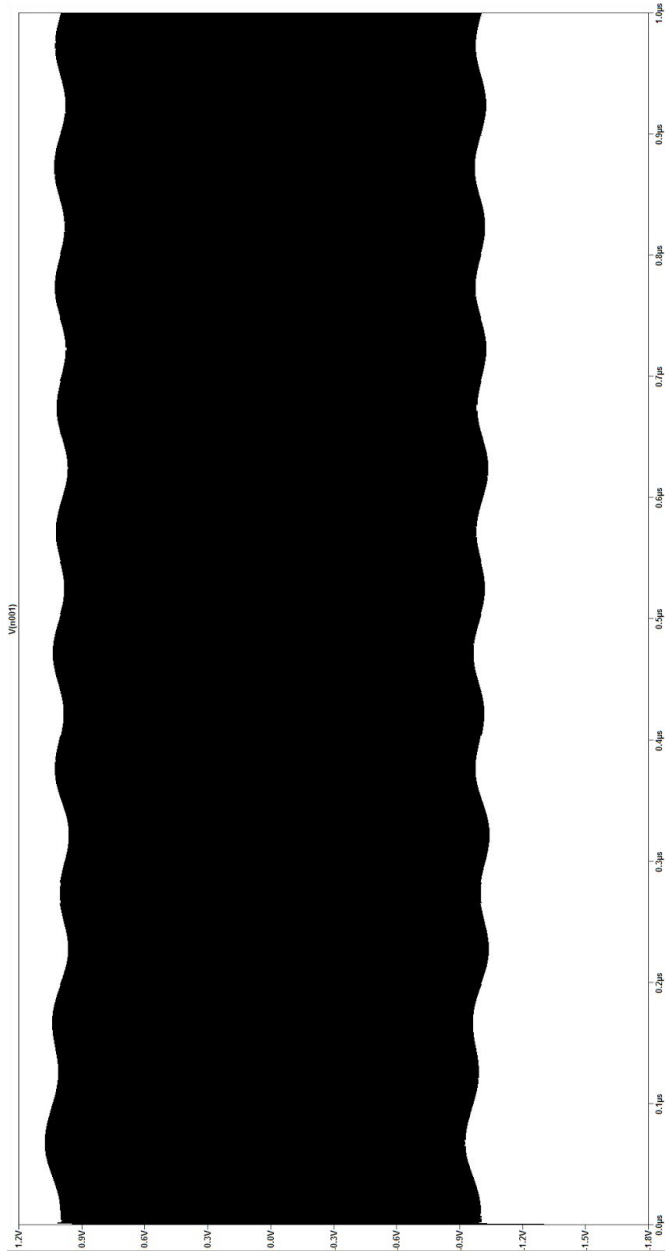

Figure 35: Voltage over time at the dipole. The signal looks solid due to the very high frequency nature of the fundamental frequency. Note the envelope of the waveform is the modulating signal. This proves that amplitude modulation could be achieved.

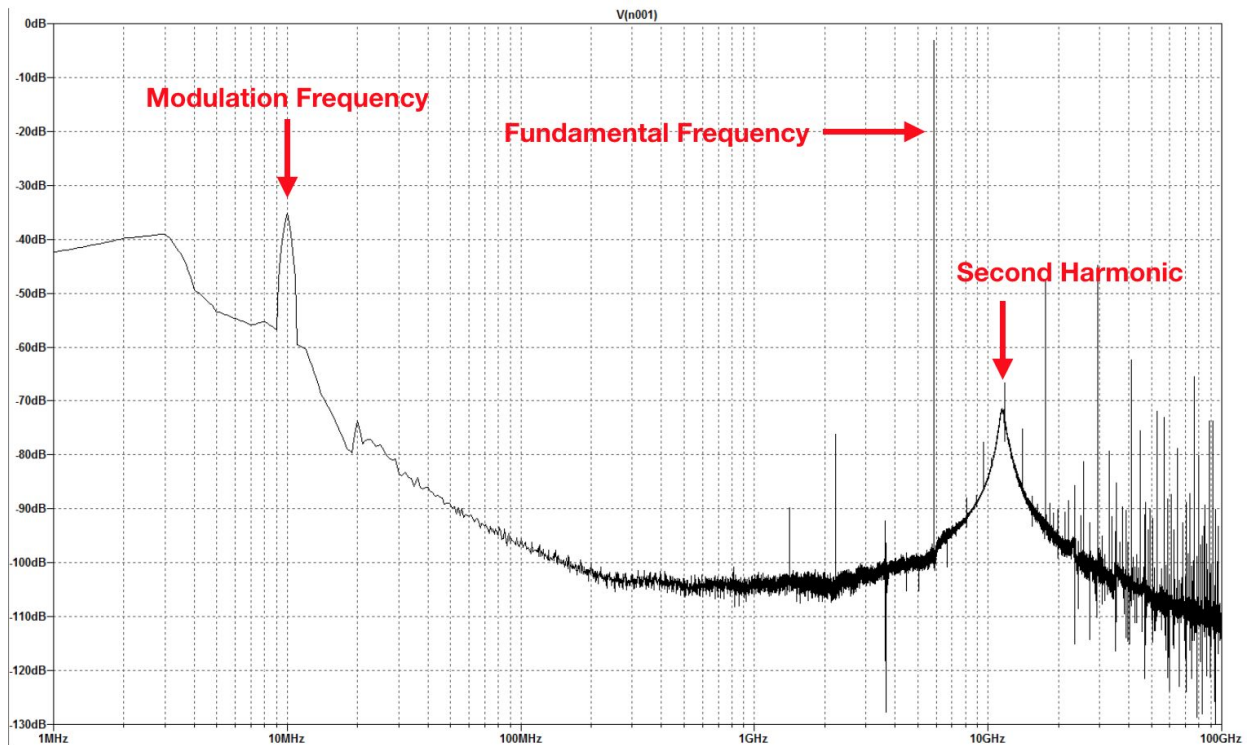

Figure 36: FFT of Figure 35's voltage over time waveform. Pointed out is the modulation frequency, the fundamental frequency and the second harmonic return frequency.

The final analog tag setup included a dynamic cartridge microphone, and audio step up transformer with 1:800 turns and this tag design.

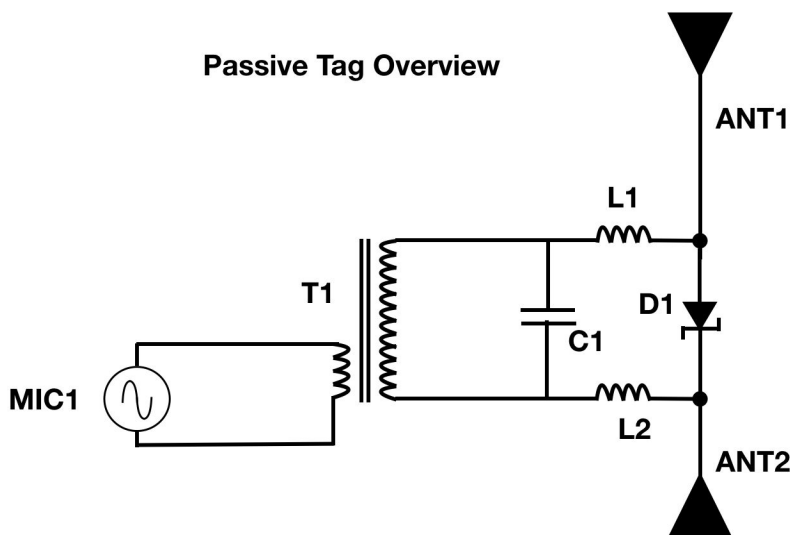

Figure 37: Final Analog Tag schematic. This tag uses a dynamic cartridge microphone and a audio step up transformer with a high turns ratio to match the impedance of the microphone to the diode setup. This allows maximum modulation power to be achieved through the diode.

Section 5: Results

The results of this project came out to be great. A full system was built and tested and a few different tags were created. All three tag designs works really well for their intended applications.

The passive tag was able to be seen for approximately 30 feet. Testing could not be taken further due to the space provided in the lab and the buildings geometry. The tag and radar system was tested using a 11.7GHz signal generator to provide a “fake” return signal. This was to prove that when the tag was put in front of the radar system’s antennas the signal seen in GNUradio was actually the tags reflection and not leak through of any harmonic produced by the transmitter itself.

Unfortunately time only allowed me to fully test the analog tag for voice recovery and the digital tag was never tested beyond concept of it working. No digital data was ever transmitted through it or recovered by the receiving system. The digital was used however in testing sine waves for their ability to be modulated. This produced tons of distortion in the received signal.

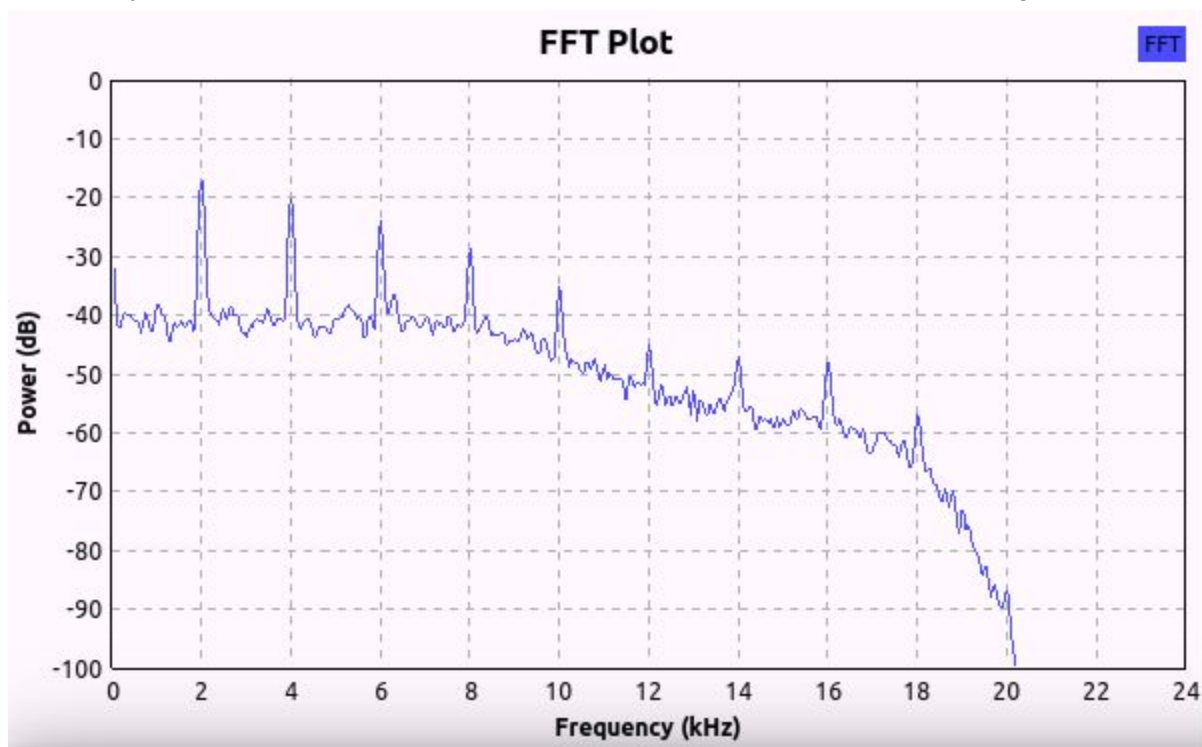

Figure 38: Harmonic distortion created by injecting a 2 kHz sine wave into the digital tag as seen by the receiver through GNUradio. Notice the high amplitude harmonics at 4, 6, and 8kHz. This indicated that if audio was ever played through this tag that it would not be able to reproduce it intelligibly at the other end.

The analog tag with the dynamic cartridge microphone worked way better than expected after plenty of experimentation. Please see the attached wav audio files. Two test pieces were played

through the system. One was the alphabet as played from a youtube video. The other was a classical music piece. The classical music piece is much harder to identify due to some critical issues that were not able to be overcome in the timespan of this project. Even though all the oscillators were locked to the same master clock, there was clear beat frequency mixing between very slight oscillator drifts. I was not able to track these down. It was possible that the LNB downconverter had the oscillator drift but it is unlikely as it is locked with a phased locked loop. I highly suspect after schematic inspection of the Ettus SDR had the oscillator drift even though it has a reference clock input. This is because the reference clock input is used in some type of FPGA digital phase lock loop that then tunes a voltage controlled oscillator as the master ADC/DAC clocks. Depending on loop constants in software it is possible it still has this very slight drift that would cause the distortion heard in the audio.

A possible solution to this would be to use some type of carrier tracking detector. In software it would be possible to design a synchronous AM detector that uses the incoming carrier as part of the baseband mixing carrier. This would be a possible next step in the project and potentially solve the beat frequency issues in the system. One of the other possible but more extreme solutions would be to change out the voltage controlled master clock in the Ettus SDR to something with more stability or something directly derived from the 10MHz master oscillator in the system.

Fortunately, voice communications through the system were much more intelligible than the musical ones. I used Audacity to further noise reduce the audio file so that the alphabet file could be easily understood. The noise reduction feature works very well. This audio file is also attached.

Section 6: Conclusion

There are lots of ideas that could be worked out on this system in the future. Basically all aspects of the project could be improved, from the antenna array to the receiving software, to tag design. I'd like to suggest that there be more ideas for what the tags could be used for. There is a lot of ways to measure our physical environment and there are lots of ways passive recording of data could be really useful. Environments don't always have ways to create energy or are non conducive to having batteries, for example too hot and very cold environments where batteries wouldn't work. This kind of environment is perfect for a passive data collection tag. I think if tags could also be cost reduced further and some type of data encoded on them, either in the form of some type of response like RFID or if the stimulus from the radar system itself could change and measure the tags properties this could be a really useful piece of technology.

Bibliography

- [1]B. G. Colpitts and G. Boiteau, "Harmonic radar transceiver design: miniature tags for insect tracking," in *IEEE Transactions on Antennas and Propagation*, vol. 52, no. 11, pp. 2825-2832, Nov. 2004.
doi: 10.1109/TAP.2004.835166
- [2]H. Aumann, E. Kus, B. Cline and N. W. Emanetoglu, "A low-cost harmonic radar for tracking very small tagged amphibians," *2013 IEEE International Instrumentation and Measurement Technology Conference (I2MTC)*, Minneapolis, MN, 2013, pp. 234-237.
doi: 10.1109/I2MTC.2013.6555415
- [3]Zuo-Min Tsai *et al.*, "A high range resolution 9.4/18.8 GHz harmonic radar for bees searching," *2012 IEEE/MTT-S International Microwave Symposium Digest*, Montreal, QC, Canada, 2012, pp. 1-3.
doi: 10.1109/MWSYM.2012.6258275
- [4]D. Psychoudakis, W. Moulder, C. C. Chen, H. Zhu and J. L. Volakis, "A Portable Low-Power Harmonic Radar System and Conformal Tag for Insect Tracking," in *IEEE Antennas and Wireless Propagation Letters*, vol. 7, pp. 444-447, 2008.
doi: 10.1109/LAWP.2008.2004512
- [5]J. Kiriazi, J. Nakakura, K. Hall, N. Hafner and V. Lubecke, "Low Profile Harmonic Radar Transponder for Tracking Small Endangered Species," *2007 29th Annual International Conference of the IEEE Engineering in Medicine and Biology Society*, Lyon, 2007, pp. 2338-2341.
doi: 10.1109/IEMBS.2007.4352795
- [6]N. Tahir and G. Brooker, "Toward the Development of Millimeter Wave Harmonic Sensors for Tracking Small Insects," in *IEEE Sensors Journal*, vol. 15, no. 10, pp. 5669-5676, Oct. 2015.
doi: 10.1109/JSEN.2015.2445933
- [7]S. Karuppuswami, M. I. M. Ghazali, A. Kaur and P. Chahal, "Multi-band Harmonic RF Tags for Barcode Applications in a Cluttered Environment," *2017 IEEE 67th Electronic Components and Technology Conference (ECTC)*, Orlando, FL, 2017, pp. 1861-1867.
doi: 10.1109/ECTC.2017.177
- [8]Dunsmore, J. (2013). *Handbook of microwave component measurements*. Hoboken, N.J.: Wiley.
- [9]Bowick, C., Blyler, J. and Ajluni, C. (2008). *RF circuit design*. 2nd ed. Amsterdam: Elsevier.

[10]Ludwig, R. and Bogdanov, G. (2009). *RF circuit design*. 2nd ed. Upper Saddle River, N.J.: Pearson Prentice Hall.

[11] <http://www.cryptomuseum.com/covert/bugs/ec/ec1/index.htm>