



Abstract

Below-the-knee (trans-tibial) amputees in Uganda cannot afford well-fitting prostheses, inhibiting working lifestyles. We utilized 3D-printing to create price-effective, well-calibrated prostheses. We aimed to increase the affordability of a trans-tibial prosthesis to enable amputees to return to the workforce.

Background

The 20,000 amputees in Uganda find it difficult to hold active jobs in agriculture, which composes 82% of Uganda's industry. The mean annual salary is \$1,500, but a traditional prosthetic limb costs more than \$50,000.

There are four main 3D printing methods. We chose fused deposition modeling (FDM) which allowed us to fabricate durable, cheaper and more precise prosthetic sockets.

Traditional Trans-tibial Prosthesis Design

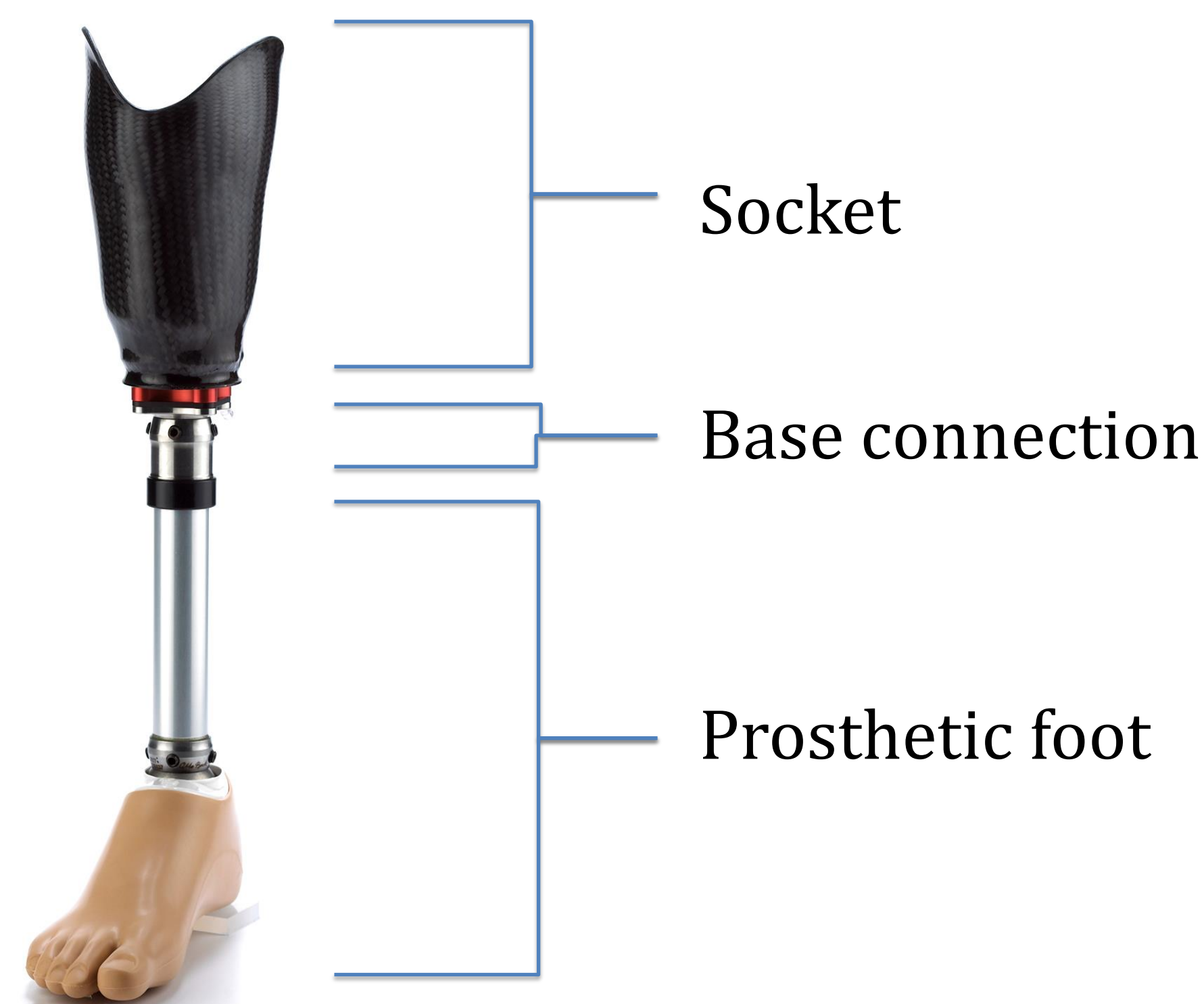

Project Goals/Objectives

Increase the accessibility of prostheses for trans-tibial amputees in northern Uganda.

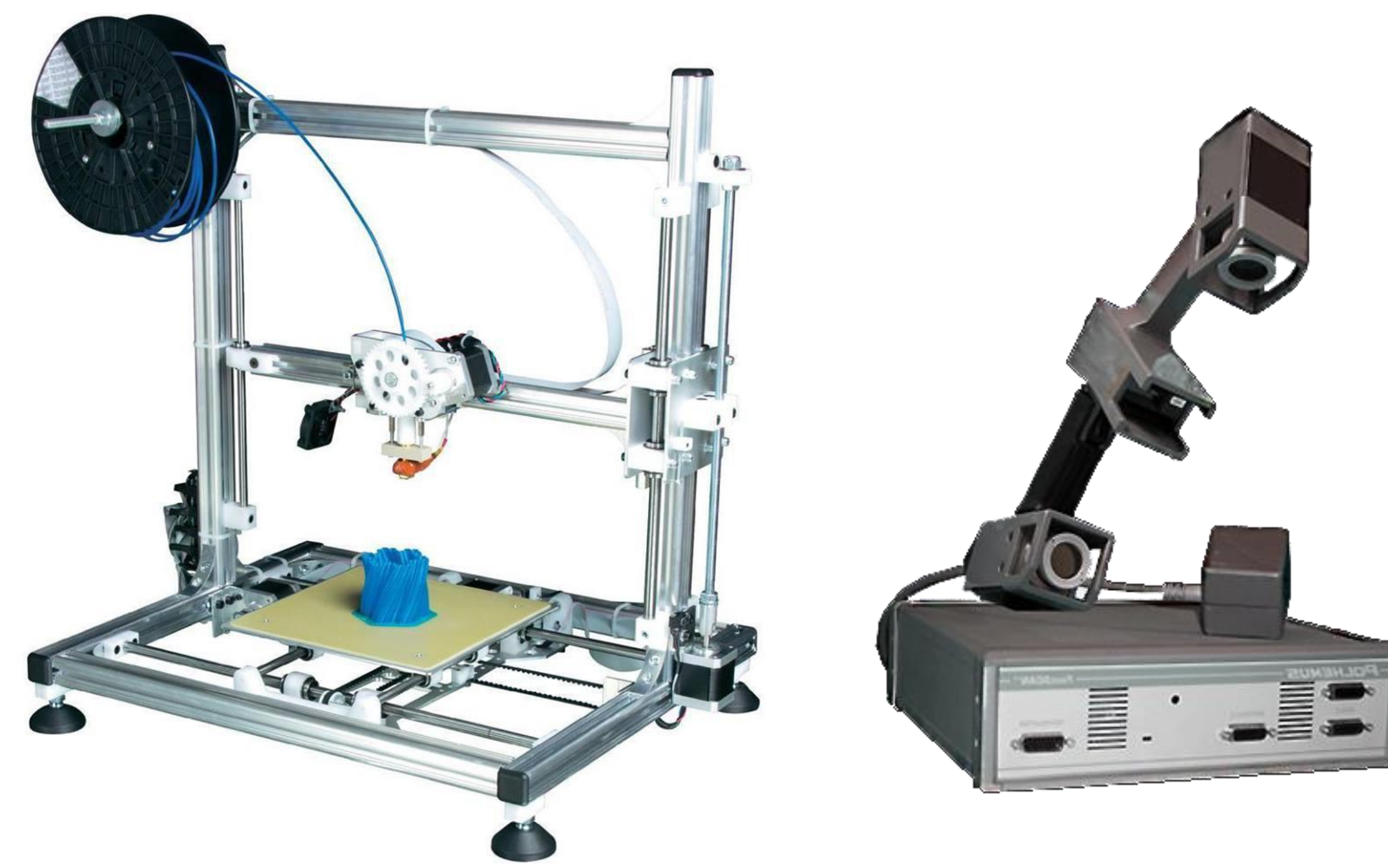

Fused deposition modeling (FDM) 3-D printer and sample 3-D scanner used to transform a residual limb to a digital model, then print a socket.

Methods/Process

- Perform preliminary survey on the need and feasibility of obtaining trans-tibial prostheses
- Collaborate with World Rehabilitation Fund to determine funding logistics
- Create a center in a developed country for processing scans
- Install scanner and printer in Gulu and Kitgum Hospitals and train technicians
- Use scan of patient residuum to design and print the prosthetic socket
- Complete follow up survey every six months

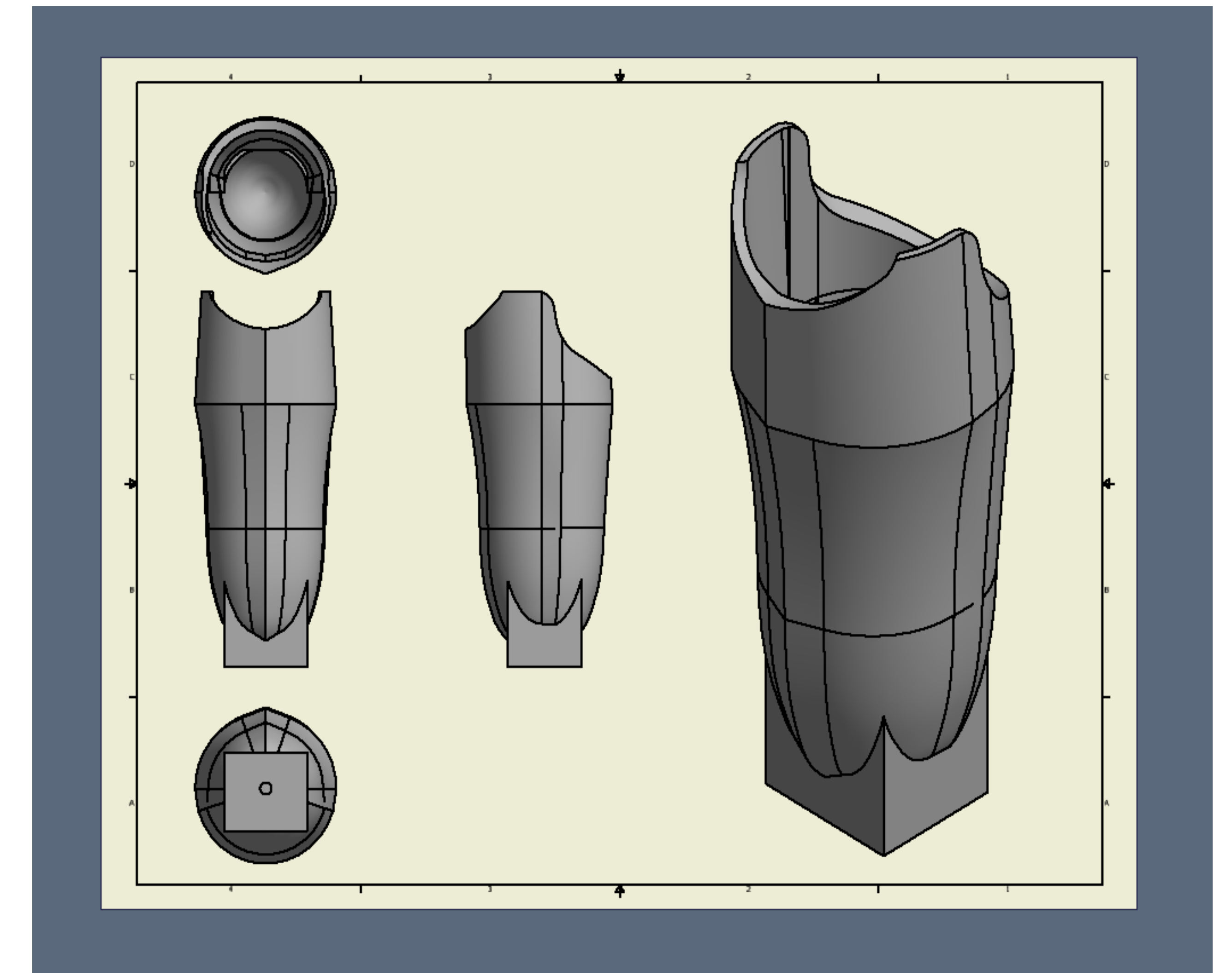

Sample 3-D Printer/CAD model angles of an example trans-tibial socket

Attributions for Success

We will compare the survey data and determine the change in the percentage of Ugandans who can afford a trans-tibial prosthesis. We will consider the project successful if we see a 20% increase in one year. With the return of hundreds of amputees to work, Uganda's economy will be positively impacted.

Included References

Bhatia, Sujata K., and Shruti Sharma. "3D-Printed Prosthetics Roll Off the Presses." *American Institute of Chemical Engineers (AIChE)* May (2014): 28-33. Print.

Sengeh, David M., and Hugh Herr. "A Variable-Impedance Prosthetic Socket for a Transtibial Amputee Designed from Magnetic Resonance Imaging Data." *JPO Journal of Prosthetics and Orthotics* 25.3 (2013): 129-37. 3 Nov. 2013. Web. 8 Nov. 2014.

Wakabi, Wairagala. "Landmines Pose Further Danger to Uganda's War Refugees." *The Lancet* 368.9548 (2006): 1637-638. *ScienceDirect*. Elsevier Ltd, 11 Nov. 2006. Web. 1 Nov. 2014

"The World Factbook: Africa: Uganda." *Central Intelligence Agency*. N.p., 20 June 2014. Web. 8 Nov. 2014.