



# Industrial Design of Simplex Small Capacity Fire Alarm Control Panel for China Tier-2

A Major Qualifying Project Report:  
Submitted to the faculty of the  
WORCESTER POLYTECHNIC INSTITUTE  
In partial fulfillment of the requirements for the  
Degree of Bachelor of Science by:

---

**Ashik K. Gowdar (ME)**

---

**Elizabeth C. Ruffa (MG)**

In Partnership with  
Shanghai University

**Partners: Jia Jun Luo, Houtao Hou, Qiong Fu**

In cooperation with  
A.J. Capowski, Bob Lin  
**Tyco International Ltd.**

Date: April 25, 2012

Approved:

---

Professor Yiming (Kevin) Rong, Advisor, ME, WPI  
Professor Helen G. Vassallo, Co-Advisor, MG, WPI  
Professor Jinsong Zhang, Co-Advisor, ME, SHU

This report represents the work of one or more WPI undergraduate student submitted to the faculty as evidence of completion of a degree requirement. WPI routinely publishes these reports on its web site without editorial or peer review.

## **Abstract**

Industrial design plays a vital role in a commercial product's success in the market. In today's market, it is seldom sufficient for a product to be technologically well engineered, as it is also important to be aesthetically pleasing, easy to use and maintain. Tyco Fire Protection Products, Shanghai is in need of designing a small capacity fire alarm control panel for the China tier-2 market. The company required assistance with industrial design of the product as it lacked resources in the area. The project team analyzed various design principles and applied them to deliver industrial design solutions for the Simplex small capacity fire alarm control panel.

## **Acknowledgements**

We would like to thank the following people for their immense support and cooperation with the project:

**A. J. Capowski**, Chief Engineer, Tyco Fire Protection Products, Westminster, MA

**Bob Lin**, Engineering Manager, Tyco Center of Excellence, Shanghai, China

**Justin Tu**, Mechanical Engineer, Tyco Center of Excellence, Shanghai, China

**Ruby Cai**, Product Manager, Tyco Center of Excellence, Shanghai, China

**Kevin Rong**, Professor in Mechanical Engineering, Worcester Polytechnic Institute, Worcester, MA

**Helen G. Vassallo**, Professor in Management, Worcester Polytechnic Institute, Worcester, MA

**Jinsong Zhang**, Professor in Mechanical Engineering, Shanghai University, China

**Jia Jun (Julian) Luo**, Shanghai University, China

**Houtao (Tony) Hou**, Shanghai University, China

**Qiong (Zale) Fu**, Shanghai University, China

# Table of Contents

|   |    |
|---|----|
| Abstract .....  | i  |
| Acknowledgements.....                                   | ii |
| Table of Figures.....                                   | iv |
| List of Tables .....                                    | v  |
| 1. Introduction .....                                   | 1  |
| 2. Background .....                                     | 2  |
| 2.1 Tyco- Company Profile .....                         | 2  |
| 2.2 Simplex Fire Alarm Control Panels.....              | 4  |
| 2.3 Principles of Design .....                          | 6  |
| 3. Methodology.....                                     | 11 |
| 4. Results .....  | 15 |
| 4.1 Results from Ideation Stage .....                   | 15 |
| 4.1.1 Design Iteration 1- Inclined Operation Panel..... | 16 |
| 4.1.2 Design Iteration 2- Draw-out Keypad .....         | 18 |
| 4.1.3 Design Iteration 3- Conventional Design .....     | 19 |
| 4.1.4 Design Iteration 4- Retractable rack design.....  | 20 |
| 4.2 Results from Analysis Stage .....                   | 21 |
| 4.3 Results from Selection Stage .....                  | 26 |
| 4.4 Results from Detailed Design Stage .....            | 26 |
| 4.5 Project Deliverables .....                          | 29 |
| 5. Conclusion.....                                      | 30 |
| 6. Bibliography .....                                   | 31 |

## Table of Figures

|  |    |
|--|----|
| Figure 1- Market Segmentation and Major Competitors of the Fire Detection Product Market as of 2012 (Cai, 2012) .....                        | 3  |
| Figure 2- The Tyco small capacity Simplex 4010 platform. (SimplexGrinnell LP, 2012) .....  | 5  |
| Figure 3- The Tyco full capacity Simplex 4100ES platform. (Center for Fire Safety - Sponsor SG) .....  | 5  |
| Figure 4- A fire panel design by the company LEADER, a UTC subsidiary .....  | 7  |
| Figure 5- Shapes illustrating the principle of emphasis .....  | 7  |
| Figure 6- FireworX fire systems panel by General Electric .....  | 8  |
| Figure 7- Picture showing an illustration depicting the principle of proportion .....  | 9  |
| Figure 8- RT 20 tischsuper radio, 1961, by Dieter Rams for Braun.....  | 9  |
| Figure 9- Flowchart showing the 10-step design process followed by the project team.....   | 11 |
| Figure 10- Figure showing the 4 components that were used across all designs- A. Keypad, B. Loop Cards, C. Transformer, and D. Battery ..... | 15 |
| Figure 11- Design iteration 1- Inclined operation panel .....  | 16 |
| Figure 12- Figure depicting the man-machine relation .....   | 16 |
| Figure 13- Design iteration 1- Open configuration .....  | 17 |
| Figure 14- Figure showing the front view of the design iteration 2 with a draw-out keypad.....   | 18 |
| Figure 15- The draw-out keypad featured in the design iteration 2 .....  | 18 |
| Figure 16- Figure showing the design iteration 3- the conventional panel design .....  | 19 |
| Figure 17- Figure showing design iteration 4- the retractable rack design .....  | 20 |
| Figure 18- Figure showing the retractable rack used in design iteration 4 .....  | 20 |
| Figure 19- Real-time render of design 1 produced in SolidWorks PhotoView 360, showing enclosed electronics.....                              | 27 |
| Figure 20- Real-time render of design 1 produced in SolidWorks PhotoView 360, in stand-alone configuration.....                              | 27 |
| Figure 21- Real-time render of design 3 produced in SolidWorks PhotoView 360, in stand-alone configuration.....                              | 28 |
| Figure 22- Real-time render of design 3 produced in SolidWorks PhotoView 360, showing enclosed electronics.....                              | 28 |
| Figure 23- Real-time render of design 3 produced in SolidWorks PhotoView 360, with the door ajar .....                                       | 29 |

## List of Tables

|  |    |
|--|----|
| Table 1- Table showing project schedule with respect to the 10-step process .....    | 12 |
| Table 2- Design 1 cost analysis. (Cai, 2012) .....                                   | 23 |
| Table 3- Design 2 cost analysis. (Cai, 2012) .....                                   | 24 |
| Table 4- Design 3 cost analysis. (Cai, 2012) .....                                   | 25 |
| Table 5- Design 4 cost analysis. (Cai, 2012) .....                                   | 25 |
| Table 6- Decision matrix summarizing the analysis of the 4 design alternatives ..... | 26 |

# 1. Introduction

Industrial design (ID) is the professional service of creating and developing concepts and specifications that optimize the function, value and appearance of products and systems for the mutual benefit of both user and manufacturer (Industrial Designers Society of America, 2012). In other words, industrial design is the combination of applied art and engineering to improve the aesthetics, ergonomics and usability of a product. In the present day market, industrial design is gaining recognition as a strategic activity that companies can use to gain a sustainable advantage over competitors (Veryzer, 1993).

Tyco Fire Protection Products (FPP) is an international conglomeration specializing in fire safety equipment. The company started operations in China within the past decade and has recently been trying to break into the China tier-2 market. The China tier-2 market boasts one of the world's highest rates of new construction. Recognizing this opportunity, Tyco FPP is trying to introduce its Simplex fire alarm control panel family into the tier-2 market. The company is currently working on Symphony Phase I, which is producing a large capacity fire alarm control panel similar to the US counterpart, Simplex 4100ES. But the market requirements for tier-2 have also necessitated Tyco FPP to design a new small capacity fire alarm control panel. Though the company has robust R&D and engineering divisions, it currently lacks resources in industrial design. Having recognized industrial design as one of the key aspects of product design, the company sought the team's help in industrial design of the Simplex small capacity fire alarm control panel for China tier-2 market.

The objective of this project is to provide Tyco FPP with industrial design solutions for the Simplex small capacity fire alarm control panel. Before embarking on achieving the objective, it is necessary to understand the background of the company, Simplex family of fire alarm control panels,

competitor products and China tier-2 market. It is equally important to identify and characterize principles of design that are applicable for the project. These aspects were dealt with during the preliminary stages of the project and they are explained in Section 2 of this report.

A 10-step design process will be followed throughout the project to carry out tasks in a systematic manner. A set of task specifications and the objectives statement act as foundations for the project and will guide the team's activities. The project's main focus is on designing the aesthetics and usability of the Simplex small capacity fire alarm control panel. By the end of the 7 weeks term, the team hopes to provide Tyco FPP with multiple design solutions to choose from. The team also hopes to provide a foundation for knowledge base about industrial design that can be used in subsequent projects.

Most of the information used in the project about Symphony Phase I is confidential. Though regular references are made in this report to the CAD models, drawings, quotations and data sheets provided by Tyco FPP, there will be no specific information presented about Symphony Phase I. The information presented in this report is strictly based on the project team's own research and findings.

## **2. Background**

### **2.1 Tyco- Company Profile**

Tyco Fire & Security Asia is a subdivision of the greater entity Tyco, and is inclusive of over 11 major Asian countries and their constituents. Of this, 11 of their 38 locations are within mainland China or Hong Kong, indicative of China's influence and importance in the global market. According to their homepage, the objectives they set for their line of products is to, "... safeguard firefighters, prevent fires, deter thieves and protect people and property." (Tyco International, Ltd., 2012)



# Market Segmentation

The fire detection product market is estimated at \$550M in 2012 (source: IMS Research, 2011).

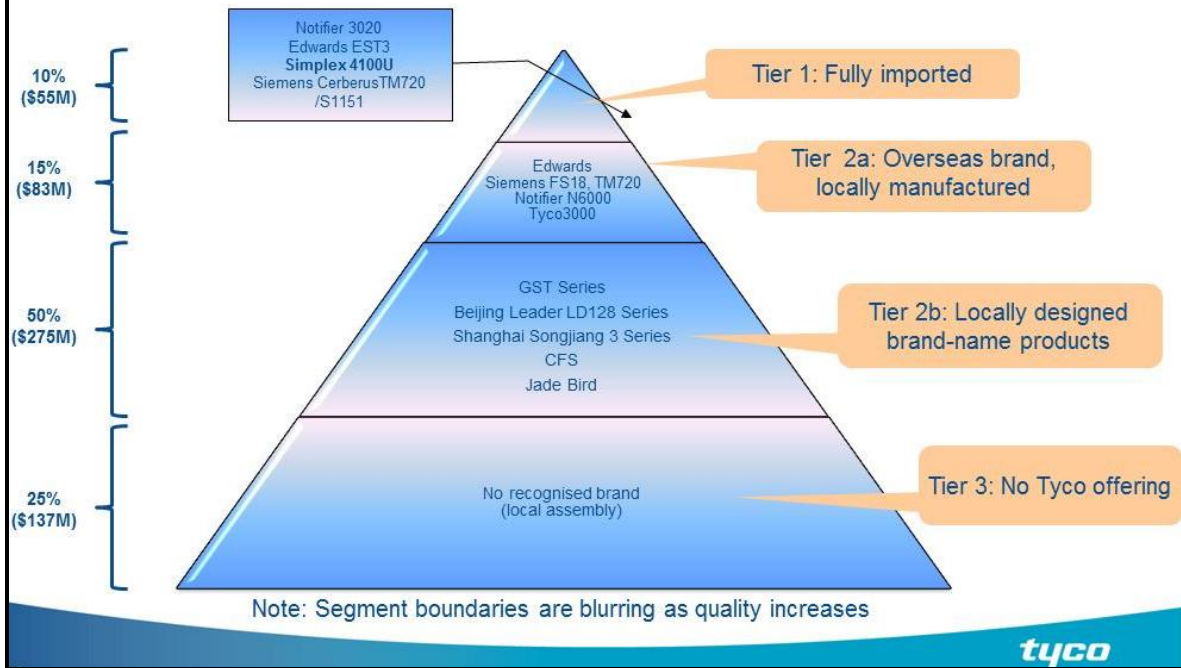

Figure 1- Market Segmentation and Major Competitors of the Fire Detection Product Market as of 2012 (Cai, 2012)

As China continues its economic ascent through the world market, competition predictably continues to increase with it at a linear rate. In conjunction with this, the Chinese tier 2a fire protection market – the aimed market for the product specified in this report – currently favors locally manufactured products as opposed to those fully internationally made, as shown in Figure 1. In order for Tyco to compete, they will need their own product in this market. However, due to the tier 2a market’s favor of locally manufactured products, this puts Tyco at an inherent disadvantage. In order to overcome this, Tyco has been looking for a design that incorporates both traits of international fire detection products that identify its brand and those closer to products developed locally in China. One fire protection segment of Tyco in particular, the Simplex family, has both the elements of world-

renown quality Tyco endeavors to exemplify, and also flexibility of design to meet specific customer's needs.

## **2.2 Simplex Fire Alarm Control Panels**

Tyco International has a number of notable subsidiaries it has acquired under its name, two of these are Simplex and Grinnell – now combined as one subsidiary known as SimplexGrinnell. SimplexGrinnell was founded in 2001 under Tyco International in the United States. It is a combination of Simplex and Grinnell, two former competitors in the fire and protection industry. Simplex, specifically, was the leader of their industry in electronic fire alarm systems at the time of Tyco's corporate acquisition in 2000 (Tyco International). The Simplex family, a conglomerate of fire panels distributed by Tyco International, became the theme behind the industrial designs produced by the project group. More specifically, two panels – Tyco 4010 and Tyco 4100 ES – were used as a guide for the designs and market models by the project team.

### **Tyco 4010 and 4100 ES platforms**

Two specific fire protection platforms of SimplexGrinnell, Tyco 4010 and Tyco 4100ES, were the primary basis for the platform designs proposed by the project team. The idea was to incorporate the Simplex family look into the exterior design, while creating a small capacity fire panel of competitive industrial quality for the Chinese tier 2a fire protection market that will be well received by the consumers. A brief description of the Tyco 4010 platform is below:

“The Simplex 4010 fire alarm system is an affordable 250-point addressable analog system for small- to mid-sized applications. Unlike many systems of this size, points can be used for detectors, modules or manual stations as needed to meet the requirements of each building.” (SimplexGrinnell LP, 2012)



Figure 2- The Tyco small capacity Simplex 4010 platform. (SimplexGrinnell LP, 2012)

The 4100ES industrial platform has been summarized below:

“The 4100ES platform is well-suited for industrial applications... it supports the full SimplexGrinnell portfolio: fire alarm, fire sprinkler, fire suppression, emergency communications, integrated security, and special hazards systems and services.” (Tyco International, Ltd., 2012)



Figure 3- The Tyco full capacity Simplex 4100ES platform. (Center for Fire Safety - Sponsor SG)

## 2.3 Principles of Design

The principles of design are the tools used by a designer to create an effective design.

Application of the principles differentiates a good design from a bad one. A design is an arrangement of the elements of art in a meaningful manner. Following are the basic elements of art (Bernard, 2001):

- **Line** – a path, mass, or edge, where length is dominant
- **Form** - the volume of the shapes
- **Texture** - the structure and minute molding of a surface (rough, smooth, etc.)
- **Color** - a characteristic pigment
- **Value** - the degree of lightness or darkness of a given color
- **Shape** - any flat area bound by line, value, or color

The quality and appeal of a design is based on how a designer uses the above mentioned elements of art in his/her work. A set of rules known as the 'principles of design' provide a qualitative measure to characterize the substance of a design. Following are the principles of design (Bernard, 2001):

- **Principle of balance** – A good design has its components balanced about both the horizontal and vertical axes.
- **Principle of movement** – Movement is the path a viewer's eye follows when they look at a design. The aim of a designer must be to limit the movement and focus it on a central theme/component. Figure 4 shows a fire panel design by the company LEADER, a UTC subsidiary in China. Note the movement of the eye when the design is viewed. The eye automatically

focuses on the bright yellow buttons first and then moves around in the light colored areas. But most of the functional buttons are in the dark colored area. Hence the design is taking the focus of the eye away from the important parts of the design and leaves it wandering about in non-functional regions.



Figure 4- A fire panel design by the company LEADER, a UTC subsidiary

- **Principle of emphasis** – Emphasis means drawing singular attention to a particular region of the design while depriving the other regions of attention. A good design uses emphasis in the important areas so as to draw a user’s attention and starves non-functional areas of the attention. Emphasis can be achieved by marked differences in size, shape, color and contrast. Figure 5 shows an illustration with differences in shape, size, color and contrast to provide emphasis to a central body.

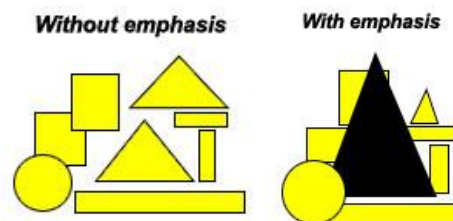

Figure 5- Shapes illustrating the principle of emphasis

- **Principle of simplicity or visual economy** – Simplicity or visual economy in design is about keeping the non-essential details that do not contribute to the overall function of the design to a minimum. A designer’s motto should be- ‘a good design is as little design as possible’. Figure 6 shows a FireworX panel by GE. The design has only one major feature, the curved black frame around the keypad. The absence of non-essential features makes the design more appealing.



Figure 6- FireworX fire systems panel by General Electric

- **Principle of proportion** – Proportion in design is the comparative relationship between two or more elements with respect to size, shape, color or contrast. A proportion is harmonious when the setting gives the user a pleasant viewing experience. A designer’s aim should always be to achieve a desirable proportion between elements. Proportion is especially important while considering dimensions of a design. Figure 7 shows an illustration depicting the difference between good and bad proportion. A popular misconception is that equal divisions cause a good proportion. This is not always true as equal divisions sometimes cause monotony.

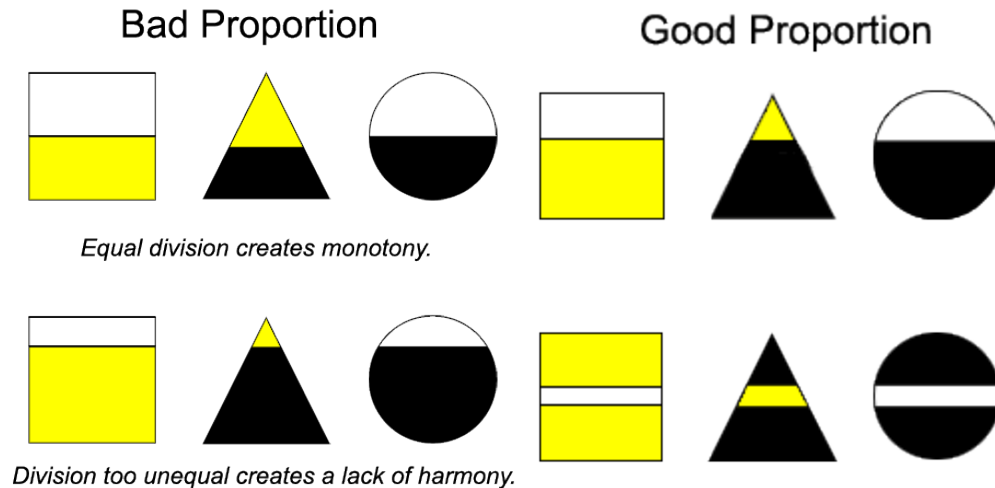

Figure 7- Picture showing an illustration depicting the principle of proportion

- Principle of unity** – Unity is the hallmark of any good design. Unity is design is achieved when the individual elements within a composition do not compete for attention; the key theme is communicated clearly; and the design evokes a sense of completeness and organization. Unity is a result of effective application of the other principles of design. Figure 8 shows a RT 20 tischsuper radio designed by the legendary industrial designer Dieter Rams in 1961 for Braun. The radio is a good example of a unified design. The design has good balance, minimized eye movement, emphasis on functional areas, visual economy and good proportion.



Figure 8- RT 20 tischsuper radio, 1961, by Dieter Rams for Braun

In addition to the above mentioned principles of design, there is another set of principles that are equally significant. Developed by Dieter Rams, a famous industrial designer credited for some of the legendary Braun products of the 1960-70s, these principles are an application of the above mentioned six principles of design. Following are Dieter Rams' ten principles for a good design (VITSOE, 2012):

1. Good design is innovative
2. Good design makes a product useful
3. Good design is aesthetic
4. Good design makes a product understandable
5. Good design is unobtrusive
6. Good design is honest and unpretentious
7. Good design is long-lasting
8. Good design is thorough, down to the last detail
9. Good design is environment-friendly
10. Good design is as little design as possible



### 3. Methodology

A 10-step design process defined by Robert L. Norton was followed over the course of the project (Norton, 2007). Figure 9 shows the flowchart representation of the 10-step process and Table 1 shows the project schedule with respect to the 10-step process.

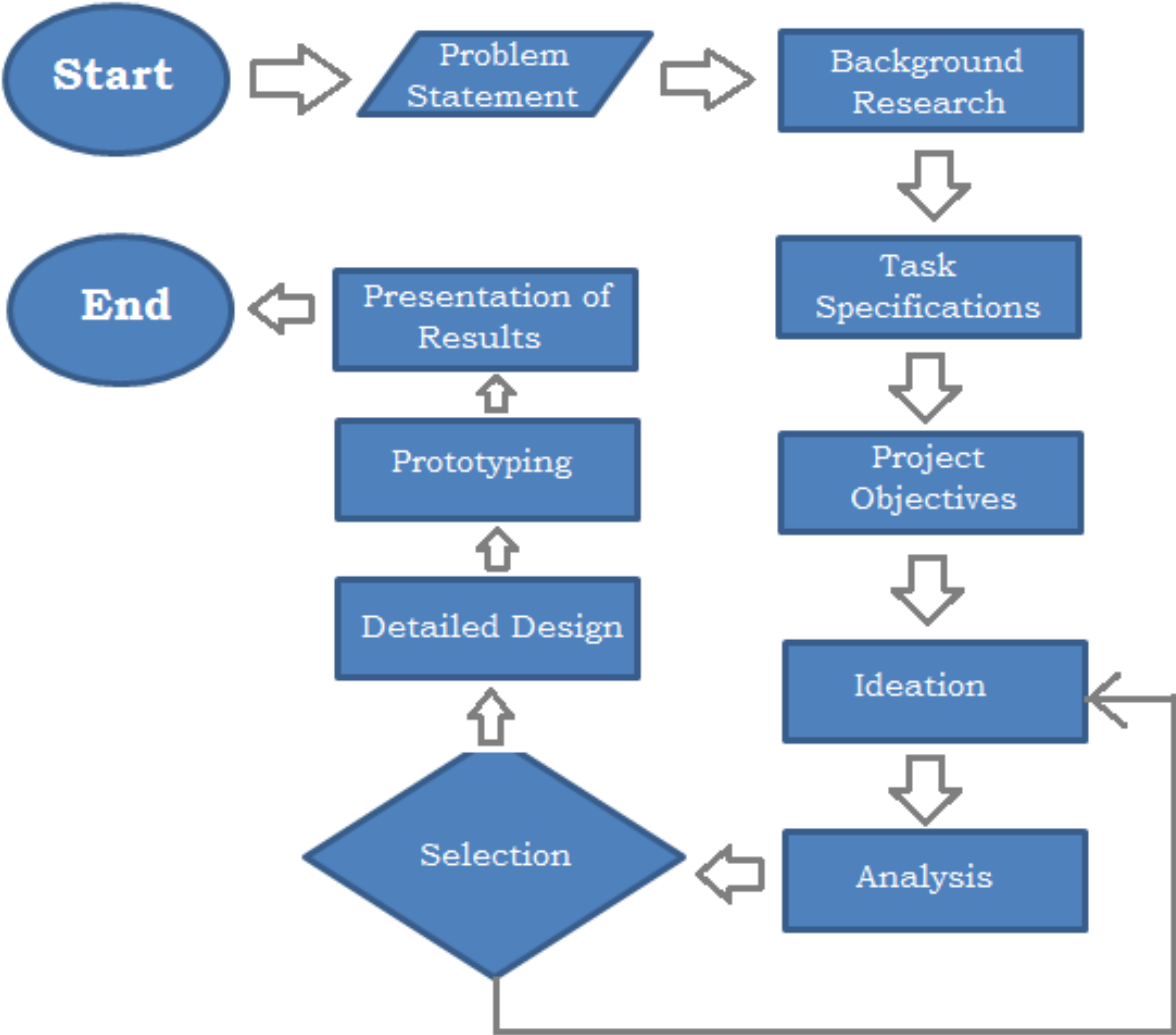

Figure 9- Flowchart showing the 10-step design process followed by the project team

| Task/Week               | Week 1 | Week 2 | Week 3 | Week 4 | Week 5 | Week 6 | Week 7 | Week 8 |
|-------------------------|--------|--------|--------|--------|--------|--------|--------|--------|
| Problem Statement       | █      | █      | █      |        |        |        |        |        |
| Background Research     | █      | █      | █      | █      | █      | █      | █      | █      |
| Task Specifications     | █      | █      | █      | █      | █      | █      | █      | █      |
| Project Objectives      |        |        | █      | █      |        |        |        |        |
| Ideation                |        |        |        | █      | █      | █      | █      | █      |
| Analysis                |        |        |        |        | █      | █      | █      |        |
| Selection               |        |        |        |        |        | █      | █      |        |
| Detailed Design         |        |        |        |        |        |        | █      | █      |
| Presentation of Results |        |        |        |        |        |        |        | █      |

Table 1- Table showing project schedule with respect to the 10-step process

- 1. Defining the problem statement** – After receiving the project proposal from Tyco FPP in late January, the first attempt at defining a problem statement was done. The process continued until the first week of MQP. The final problem statement was verified by the company representatives and finalized by the end of the first week of MQP. The problem statement reads- *“Tyco Fire Protection Products, Shanghai is in need of designing a new mechanical enclosure for its Simplex small capacity fire alarm control panel in order to be competitive in the China tier 2 market. But the company currently lacks resources in industrial design. So, our project team has been asked to research industrial design principles and apply them to formulate new design alternatives for the Simplex small capacity fire alarm control panel”.*
- 2. Background research** – Background research was started during the preparatory PQP stage of the project. One of the first topics researched was the company profile of Tyco International Ltd. As part of background research, the team visited the Tyco FPP facility in Westminister, MA. The Chief Engineer A. J. Capowski introduced the team to Tyco product lines and gave a basic description about the nature of the project. When the objectives of the project became clearer during the first week of MQP in China, the team started detailed background research about Tyco’s China Simplex fire panels, competitor products, China tier-2 market and principles of

industrial design. Background research helped the team gain an understanding about the tasks that required to be done and ways to accomplish the tasks. Background research is presented in detail in Section 2.

**3. Developing task specifications** – First attempts at developing task specifications were made during the PQP stage but clarity and detail were only achieved once reaching China. During the first two company visits in Shanghai, the task specifications were discussed and finalized in consultation with the company manager and the mechanical engineer. The task specifications were the benchmarks against which the team’s design solutions could be held against towards the end of the project. Following are the task specifications that were developed by the team in consultation with Tyco:

- I. The design must comply with China Compulsory Certificate-Fire (CCC) standards
- II. The design must have a reliable, high quality appearance with a Simplex panel family look
- III. The design must be comparable in size with competitor products
- IV. The design must reuse button and LCD designs from Symphony Phase I
- V. The design must be optimized for manufacturing
- VI. The total manufacturing cost (TMC) for the design must be less than 1000 RMB
- VII. The design must allow easy access to internal components for ease of maintenance and repair
- VIII. The design must be safe to use
- IX. The design must be dustproof
- X. The design must allow for easy and systematic wiring

4. **Defining project objectives** – The project objective was defined as –*“The objective of the project is to provide Tyco International with a new design for the Simplex tier 2 fire alarm control panel cabinet, focusing on industrial design of the cabinet”*.
5. **Ideation** – Different design solutions were brainstormed during this stage and 4 design alternatives were developed and presented to Tyco. The design alternatives are detailed in the ‘Results’ section.
6. **Analysis of design alternatives** – A decision matrix was developed to analyze and compare the design alternatives. The parameters for analysis were- size, ease of use, ease of maintenance, visual appeal, material cost, ease of wiring and company preference.
7. **Selection of the best design alternative** – Two design alternatives were selected for further consideration based on the design decision matrix.
8. **Detailed design** – A detailed industrial design of the two selected designs was done during this stage. The process yielded 3D CAD models (in SolidWorks and STEP AP 214 format) that would be delivered to the company at the end of the project. The goal of this process was to have the designs meet or exceed the task specifications. Each of the two designs was worked on by two team members. At the end of this phase, one of the mini teams had focused largely on the mechanical structure while the other had largely focused on aesthetics of the fire panel.
9. **Prototyping** – Physical prototyping was not possible due to the shortage of time and sheet metal processing facilities. But real-time rendering of the 3D CAD models was done using SolidWorks PhotoView 360 for a more realistic representation of the CAD designs.

**10. Presentation/delivery of results** – The final presentation of the project was held on April 24, 2012 in Shanghai University campus. The presentation was attended by project advisors and an engineer from Tyco. 3D CAD models (in SolidWorks and STEP AP214 format) of the design solutions were delivered to the company engineers at the end of the project.

## 4. Results

### 4.1 Results from Ideation Stage

For consistency across design alternatives, four components from the existing design were used in the design process as shown in Figure 10.

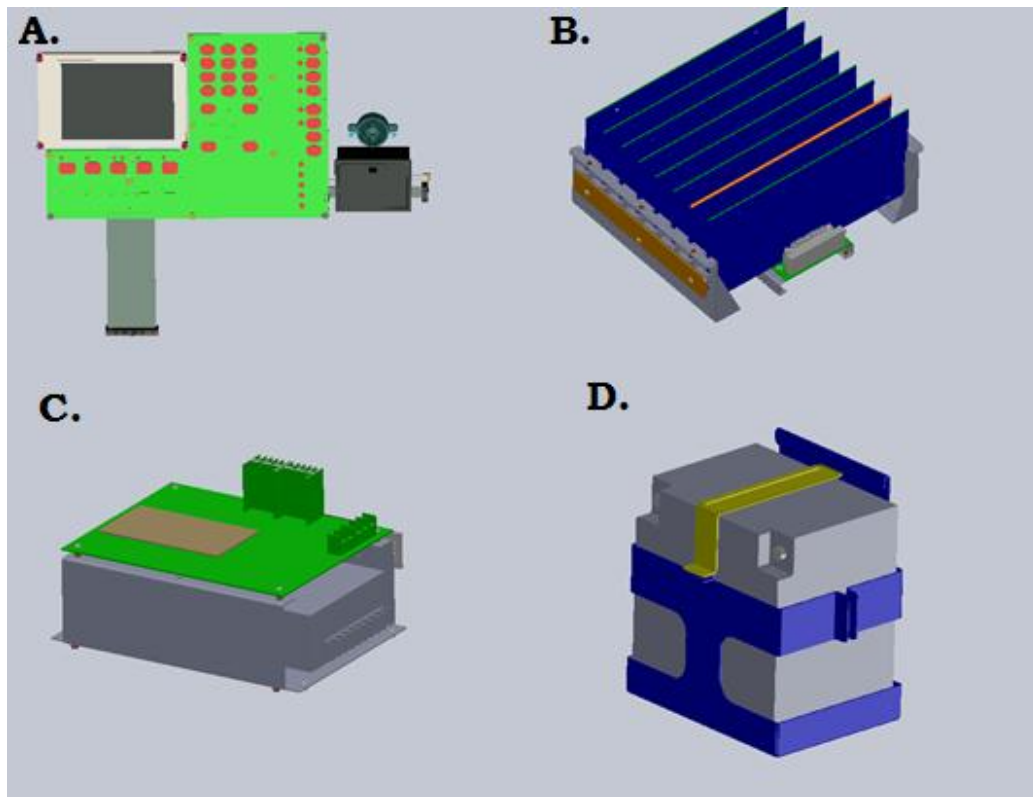

Figure 10- Figure showing the 4 components that were used across all designs- A. Keypad, B. Loop Cards, C. Transformer, and D. Battery

#### 4.1.1 Design Iteration 1- Inclined Operation Panel



Figure 11- Design iteration 1- Inclined operation panel



图 3 操作者与控制面板人机交互关系图

Figure 12- Figure depicting the man-machine relation

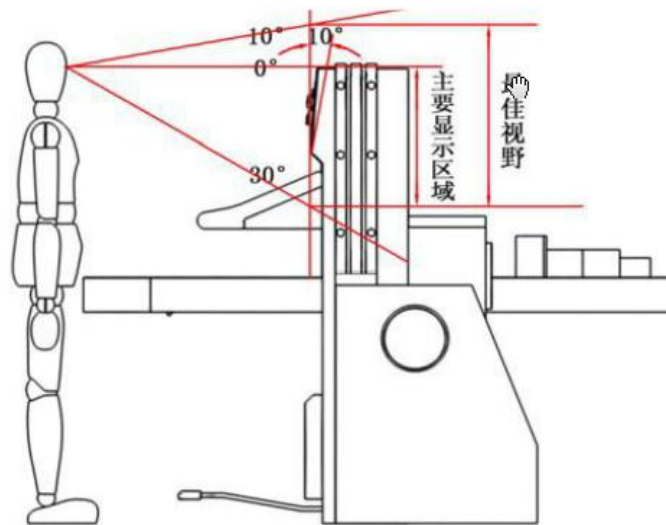
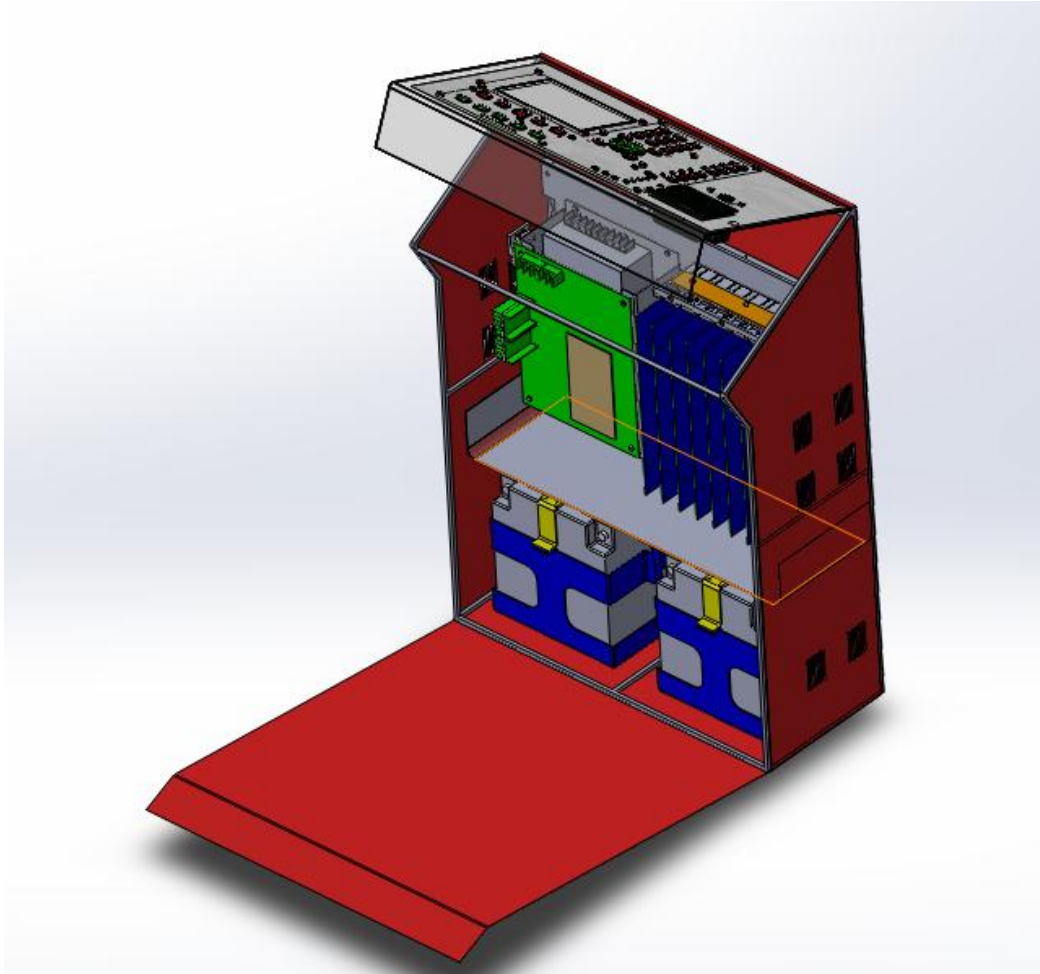

**Figure 13- Design iteration 1- Open configuration**

Design iteration 1 featured an inclined operation panel as shown in Figure 11. By man-machine relationship, it was determined that a 30 degree inclination with respect to the vertical axis offered the best interaction with the control panel as shown in Figure 12. The design was constructed out of sheet metal, as sheet metal fabrication is cheaper than plastic injection molding. To aid ease of maintenance, the design featured a one-level entry to the enclosed components. The PCBs were directly mounted on to the sheet metal box as shown in Figure 13 in order to save manufacturing costs from complicated structures as those featured in the existing Simplex 4036 large capacity fire panel. The overall size of the cabinet was 660 x 460 x 225 mm (Height x Width x Depth).

#### 4.1.2 Design Iteration 2- Draw-out Keypad

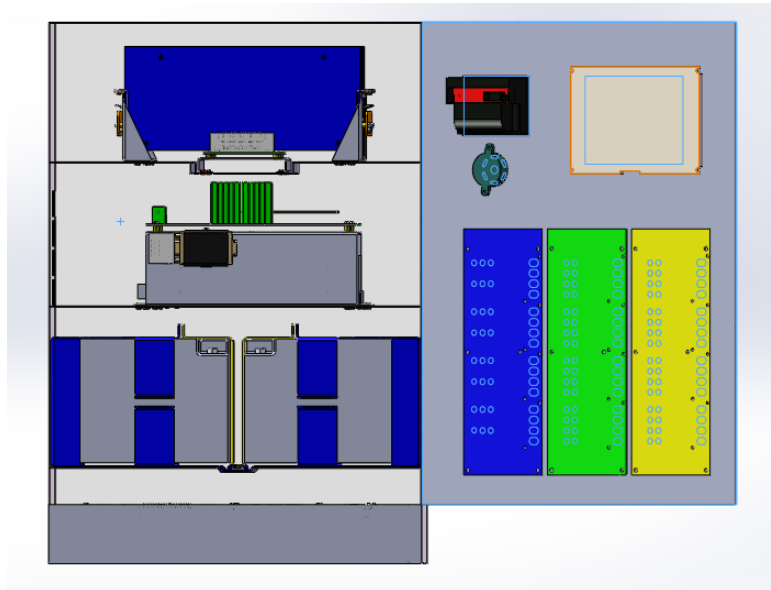

Figure 14- Figure showing the front view of the design iteration 2 with a draw-out keypad

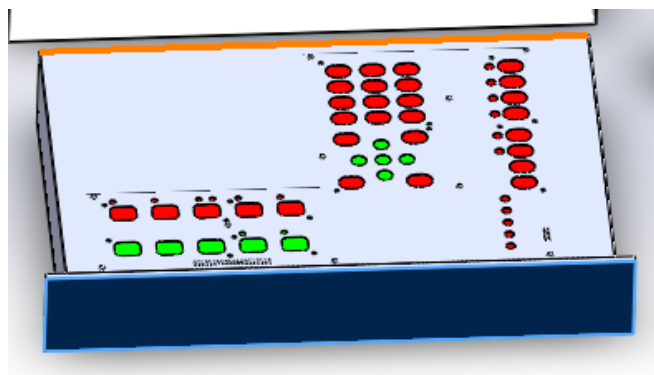

Figure 15- The draw-out keypad featured in the design iteration 2

Design iteration 2 featured a draw-out keypad in order to save space on the cabinet. The cabinet was again constructed out of sheet metal and the PCBs were directly mounted on the sheet metal box. The LCD, printer and speaker were mounted on the sheet metal door for ease of use. The design used a one-level entry to the enclosed components for ease of maintenance. The sheet metal box was compartmentalized to aid in wiring the loop card and the transformer. The overall size of the design was 550 x 380 x 230 mm (Height x Width x Depth).



### 4.1.3 Design Iteration 3- Conventional Design

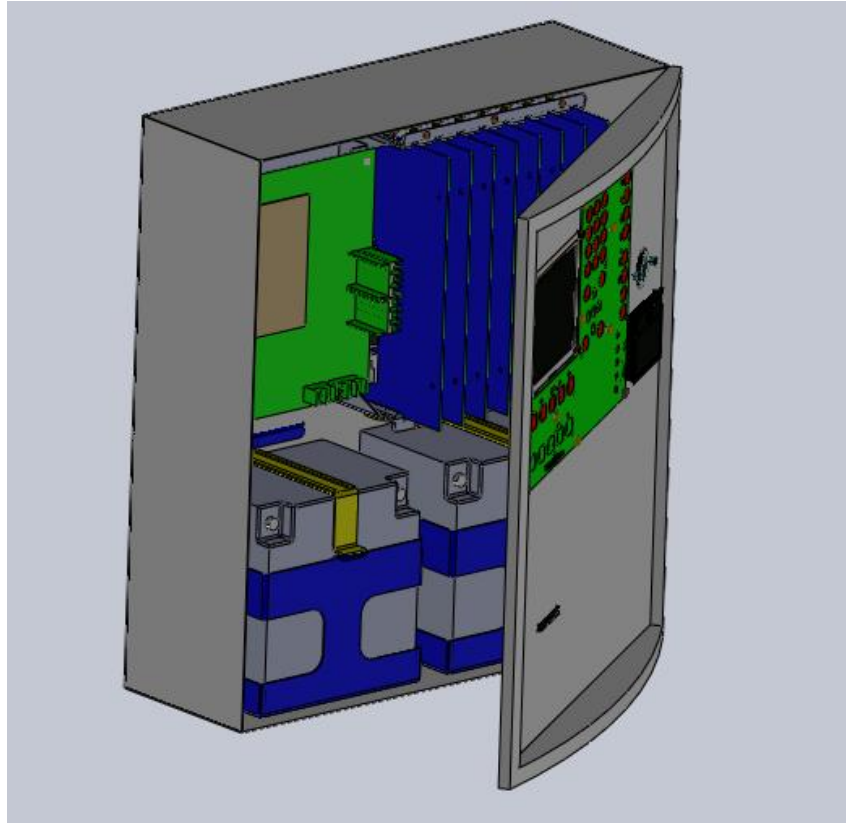

Figure 16- Figure showing the design iteration 3- the conventional panel design

Design iteration 3 was more of a conventional design that is popular with a lot of the competitors. It features a single door one-level entry configuration. The keypad controls, LCD, printer and the speaker are all mounted on the main door. The door is made of plastic, which though is a bit more expensive than sheet metal, yields itself to be molded into complex shapes increasing opportunities for industrial design. The design is also straightforward to use and repair. The design offers the smallest package of all the design alternatives. The overall size of the cabinet is 550 x 450 x 188 mm (Height x Width x Depth).

#### 4.1.4 Design Iteration 4- Retractable rack design

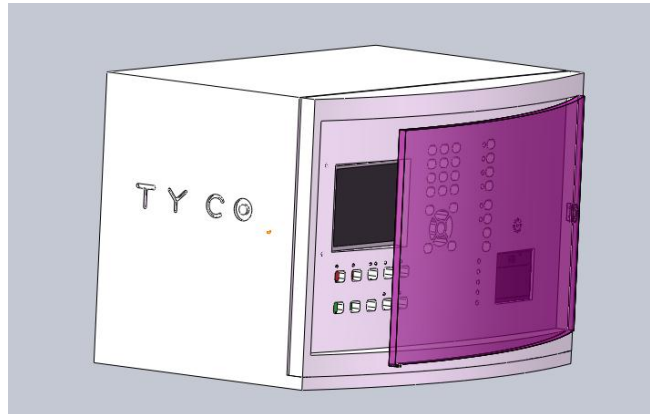

Figure 17- Figure showing design iteration 4- the retractable rack design

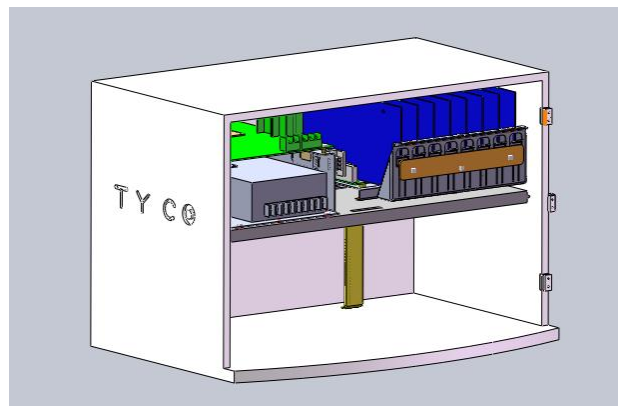

Figure 18- Figure showing the retractable rack used in design iteration 4

Design iteration 4 features a retractable rack mounted on a movable track in the middle of the sheet metal box as shown in Figure 18. The idea is to mount all the electronics on the retractable rack to help ease maintenance situations. In case of maintenance issues, the repairer will simply be able to pull the rack out of the box, carry out the repair out and push the rack back into the box. The design has the keypad, LCD, printer and speaker mounted on the main door as shown in Figure 17. The glass door protects the control panel and adds to the aesthetics of the design. This is the only design that was considered with a two-level entry system. The first level of entry is the glass door and the second level of entry is the main door. The overall size of the package is 335 x 500 x 345 mm (Height x Width x Depth).

## 4.2 Results from Analysis Stage

A decision matrix was developed to analyze and compare each of the designs as shown in Table 6. Each design was rated on a scale of 2 to 5 with 5 being the best design for a certain parameter and 2 being the worst. Parameters were also weighted based on the importance each carried in the final package. The total points for each design were the sum of weighted ratings for each parameter. A design with the higher rating was preferred over the one with a lower rating. Following were the parameters that were considered:

1. **Size** – The average size of the competitor products is 390 x 420 x 200 mm (H x W x D). So it is essential for the team’s design to be similar in size with the competition. Size being an important factor, was weighted 20%. The smallest design received 5 points while the largest received 2 points. Design 3 was found to have the smallest size while design 4 the largest.
2. **Visual appeal** – As the project is focused on industrial design, visual appeal was considered an important parameter. The parameter was weighted 20% and the best looking design received 5 points while the worst looking received 2 points. Though visual appeal is a subjective quantity, the points were awarded based on the team consensus, company feedback and innovativeness of the design. It was decided that design 1 was the most creative, visually appealing solution while design 2 was the least visually appealing.
3. **Ease of use** – Ease of use represents the straightforwardness of the design for a new user. The parameter was weighted 10%. Owing to the use of an inclined control panel and a better man-machine relationship, design 1 had the best ease of use, while the draw-out keypad made design 2 the worst.

4. **Ease of maintenance** – Ease of maintenance represents the ease with which a technician can perform maintenance activities on the enclosed electronics. The parameter was weighted 10%. The retractable track placed design 4 as the best design for ease of maintenance while design 2 was the worst.
5. **Ease of wiring** – Being a fire alarm control panel, the cabinet accommodates electronic circuitry that has to be wired. Wiring can be a quite messy business if not laid out in an organized manner. Ease of wiring represents the ease with which wiring can be performed and organized in the system. The parameter was weighted 10%. Due to its uncomplicated design, design 3 had the best ease of wiring, while the complications caused by the draw-out keypad made design 2 the worst.
6. **Company preference** – This score represents the preference of the company for a design. As we are developing the design for the company, their feedback was considered very important and the parameter was weighted at 20%. The company representatives favored design 1 the most due to its creative approach.
7. **Material cost** – Being unable to get manufacturer quotations for the designs, only the material cost was taken into account while comparing the designs. Also, the team recognized that the designs being very similar and having similar fabrication methods would cost identical to manufacture. As cost was not a primary concern at this stage of industrial design, the parameter was only weighted 10%. The following tables are individual cost analyses of the platform designs proposed by the engineering project members. The factors taken into the cost analysis were determined by materials used only, in current RMB prices, and do not take into account

machining, labor, or any other external costs otherwise factored in to making the product. It was found that design 3 was the most cost effective solution while design 1 was the worst.

### Design 1 Material Cost

| Serial number | Material           | dimensions(mm) | weight (kg) | quantity     | Cost (RMB)    |
|---------------|--------------------|----------------|-------------|--------------|---------------|
| 1             | Hollow steel tube  | 10*10*6750     | 12          | 1            | 96            |
| 2             | sheet metal (SGCC) | 510*40*1       | 1.7         | 1            | 20.4          |
|               |                    | 650*200*1      | 0.75        | 1            | 9             |
|               |                    | 650*200*2      | 0.75        | 1            | 9             |
|               |                    | 460*650*1      | 2.2         | 1            | 26.4          |
|               |                    | 570*150*1      | 0.62        | 1            | 7.44          |
|               |                    | 190*460*1      | 0.63        | 1            | 7.56          |
|               |                    | 460*332*1      | 1.08        | 1            | 12.96         |
| 3             | Hinge              |                |             | 4            | 20            |
| 4             | Lock               |                |             | 2            | 10            |
|               |                    |                |             | <b>Total</b> | <b>218.76</b> |

Table 2- Design 1 cost analysis. (Cai, 2012)

### Design 2 Material Cost

| number | Name | weight (kg) | Material | Size        | Unit Price | Material cost | Total cost (RMB) |
|--------|------|-------------|----------|-------------|------------|---------------|------------------|
| 1      | Box  | 4.455       | Fe:SGCC  | 550*380*230 | 6          | 26.73         | 53.46            |

|   |                    |         |                  |            |   |              |                 |
|---|--------------------|---------|------------------|------------|---|--------------|-----------------|
|   |                    |         | T:1.0            |            |   |              |                 |
| 2 | Door               | 1.16975 | Fe:SGCC<br>T:1.0 | 380*490    | 6 | 7.0185       | 14.037          |
| 3 | drawer             | 1.5592  | Fe:SGCC<br>T:1.0 | 225*380*59 | 6 | 9.3552       | 18.7104         |
| 4 | panel              | 0.51175 | Fe:SGCC<br>T:1.0 | 225*353    | 6 | 3.0705       | 6.141           |
| 5 | expansion<br>plate | 1.854   | Fe:SGCC<br>T:1.0 | 378*225    | 6 | 11.124       | 22.248          |
|   |                    |         |                  |            |   | <b>Total</b> | <b>114.5964</b> |

**Table 3- Design 2 cost analysis. (Cai, 2012)**

**Design 3 Material Cost**

| number | name   | dimension (mm) | weigh (kg) | Material       | price (RMB)  |
|--------|--------|----------------|------------|----------------|--------------|
| 1      | Box    | 505*455*1      | 4          | Fe:SGCC, T=1.5 | 48.00        |
|        |        | 505*155*2      |            | Fe:SGCC, T=1.5 |              |
|        |        | 455*155*2      |            | Fe:SGCC, T=1.5 |              |
| 2      | Door   | 500*450*37.8*1 | 1.5        | Plastic        | 18.00        |
| 3      | Others |                |            |                | 20.00        |
|        |        |                |            | <b>Total</b>   | <b>86.00</b> |

**Table 4- Design 3 cost analysis. (Cai, 2012)**

**Design 4 Material Cost**

| number | name                    | dimension (mm) | weight (kg) | material                 | price (RMB)   |
|--------|-------------------------|----------------|-------------|--------------------------|---------------|
| 1      | door                    | 500*320*1      | 1.1         | Fe:SGCC,<br>T=1.0, T=1.5 | 13.2          |
| 2      | board                   | 471*240*15     | 0.86        | Fe:SGCC,<br>T=1.0, T=1.5 | 10.32         |
| 3      | glass door              | 500*207*3      | 0.9         | glass                    | 10.8          |
| 4      | box                     | 328*280*1      | 4.5         | Fe:SGCC,<br>T=1.0, T=1.5 | 54            |
|        |                         | 328*280*1      |             |                          |               |
|        |                         | 500*280*1      |             |                          |               |
|        |                         | 500*280*1      |             |                          |               |
| 5      | others (hinge,<br>rail) |                |             |                          | 20            |
|        |                         |                |             | <b>Total:</b>            | <b>108.32</b> |

**Table 5- Design 4 cost analysis. (Cai, 2012)**

| Parameter                 | Design 1 | Design 2 | Design 3 | Design 4 |
|---------------------------|----------|----------|----------|----------|
| Size (20%)                | 3 (0.6)  | 4 (0.8)  | 5 (1.0)  | 2 (0.4)  |
| Visual Appeal (20%)       | 5 (1.0)  | 2 (0.4)  | 3 (0.6)  | 4 (0.8)  |
| Ease of Use (10%)         | 5 (0.5)  | 2 (0.2)  | 4 (0.4)  | 3 (0.3)  |
| Ease of Maintenance (10%) | 3 (0.3)  | 2 (0.2)  | 4 (0.4)  | 5 (0.5)  |

|                          |          |         |            |         |
|--------------------------|----------|---------|------------|---------|
| Ease of Wiring (10%)     | 4 (0.4)  | 2 (0.2) | 5 (0.5)    | 3 (0.3) |
| Company Preference (20%) | 5 (1.0)  | 2 (0.4) | 4 (0.8)    | 3 (0.6) |
| Material Cost (10%)      | 2 (0.2)  | 3 (0.3) | 5 (0.5)    | 4 (0.4) |
| Weighted Total           | <b>4</b> | 2.5     | <b>4.2</b> | 3.3     |

**Table 6- Decision matrix summarizing the analysis of the 4 design alternatives**

### **4.3 Results from Selection Stage**

Based on the design decision matrix shown in Table 6, design 1 and design 3 were chosen for further detailed design. Design 3 was conditionally selected by the company and the team was suggested to improve the aesthetics of the design.

### **4.4 Results from Detailed Design Stage**

The detailed design stage mainly focused on industrial design of the chosen design solutions, design 1 and design 3. Design 1 was kept as is it expect for the front door. The downward-opening door in the preliminary design was replaced with a sideward-opening door to improve ergonomics. Details like structure, screws, handles, etc. were added to the design and a real time render was produced in SolidWorks. Figure 19 and Figure 20 show the renders for design 1.

The plastic door of design 3 was heavily modified to feature a curved surface. According to principles of design, the curved surface focusses a viewer’s eye to the control panel, minimizes eye movement and provides emphasis to the control panel; while maintaining visual economy. The control panel plate is made of aluminum and has a brushed-aluminum finish for enhanced visual appeal. Figure 21, Figure 22 and Figure 23 show the real-time renders for design 3.



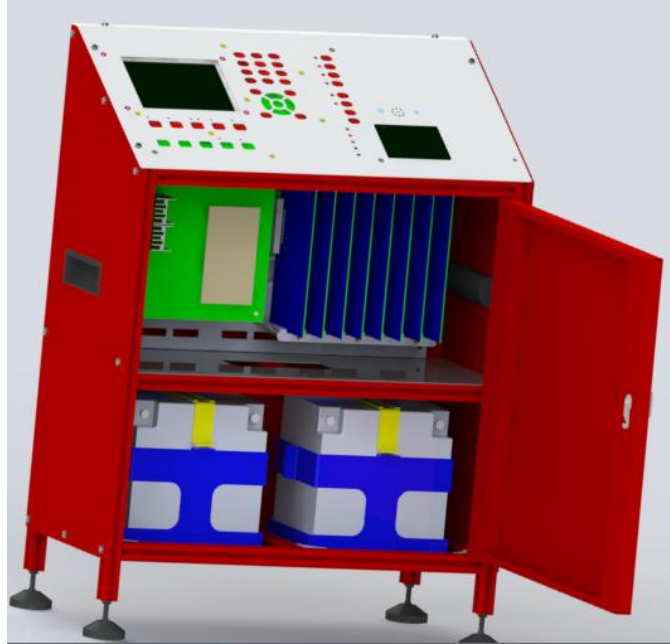

Figure 19- Real-time render of design 1 produced in SolidWorks PhotoView 360, showing enclosed electronics



Figure 20- Real-time render of design 1 produced in SolidWorks PhotoView 360, in stand-alone configuration



Figure 21- Real-time render of design 3 produced in SolidWorks PhotoView 360, in stand-alone configuration

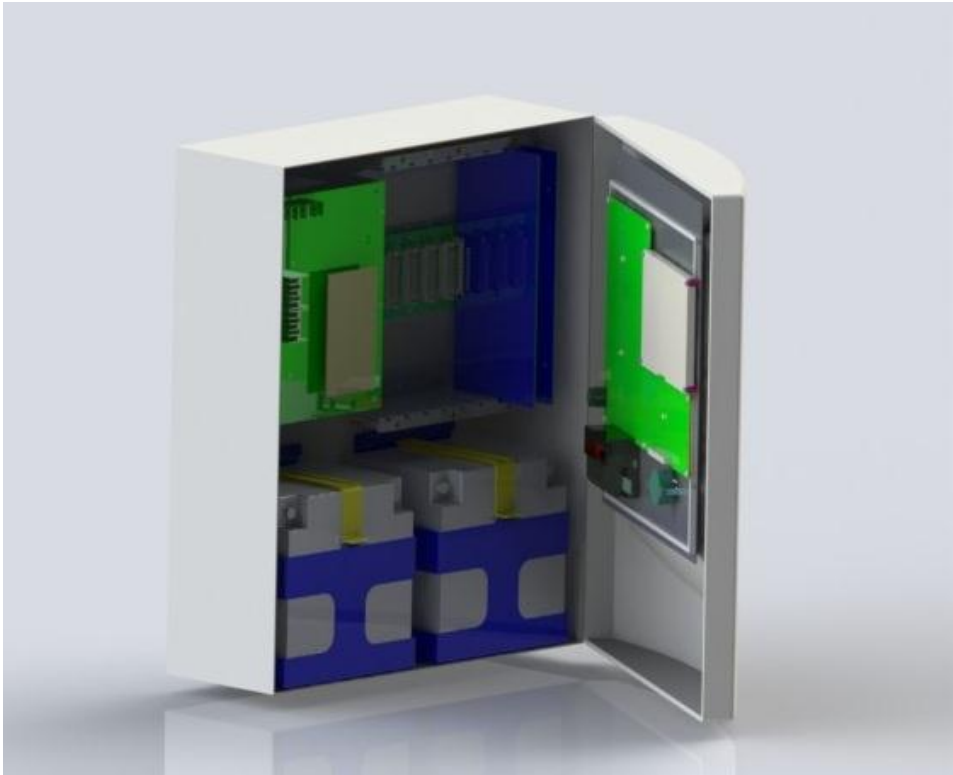

Figure 22- Real-time render of design 3 produced in SolidWorks PhotoView 360, showing enclosed electronics



Figure 23- Real-time render of design 3 produced in SolidWorks PhotoView 360, with the door ajar

## 4.5 Project Deliverables

As part of project deliverables, 3D CAD models of design 1 and design 3 were given to Tyco FPP, Shanghai in SolidWorks 2012 and STEP AP214 formats. Final presentation of results was held on April 24, 2012 at the Shanghai University campus and was attended by the project advisors and Justin Tu, the project mentor from Tyco FPP. The results of the project were well received by both the advisors and Tyco representatives.

## 5. Conclusion

In the eight weeks that spanned the project, the project team was successfully able to gain an understanding of industrial design; and apply the principles of industrial design to develop two design solutions for Tyco's Simplex small capacity fire alarm control panel. The team gained valuable experience in following a systematic design process and working in real-world conditions. The project also emphasized the importance of cross-cultural collaboration in international projects. Being a diverse team, each member's strengths had to be understood and utilized in the right manner to achieve results. By the end of eight weeks, the team had formed a strong working relationship within itself and the sponsors.

The main challenge that was faced during the project was delay in relay of project specific information from the company to the project team. This problem was caused as our project activities were well ahead of the company's product development cycle. A lot of specific information related to the Simplex small capacity fire alarm control panel was not yet worked out by Tyco engineers since the product was not slated for release until at least 2014. This challenge was overcome by using information related to the existing designs whenever a void was encountered.

Future work related to the Simplex small capacity fire alarm control panel can study manufacturing of the product and optimize the designs that we have provided for fabrication. We also recommend future industrial design projects to consider using more sophisticated surface modeling tools such as Autodesk Maya as opposed to CAD tools such as Pro/Engineer or SolidWorks. Sophisticated surface modeling tools will provide greater design capabilities and expand the creative space available to a designer.

## 6. Bibliography

- Bernard, T. (2001). *Introduction To The Principles of Good Design*. Retrieved from Bluemoon Design:  
<http://www.bluemoonwebdesign.com/art-lessons.asp>
- Cai, R. (2012). Cost Analysis and Marketing Segmentation. (E. C.Ruffa, Interviewer) Shanghai, Cao He Jing, China. Retrieved 2012
- Center for Fire Safety - Sponsor SG. (n.d.). Retrieved April 25, 2012, from  
<http://www.campusfiresafety.org/sponsor-sg>
- Industrial Designers Society of America. (2012, April 20). *iDSA-Education*. Retrieved April 20, 2012, from  
<http://www.idsa.org/>
- Norton, R. (2007). *Design of Machinery: An introduction to the synthesis and analysis of mechanisms and machines (4th Ed.)*. McGraw-Hill Companies.
- SimplexGrinnell LP. (2012). *4010 Fire Alarm Panel*. Retrieved April 25, 2012, from SimplexGrinnell:  
<http://www.simplexgrinnell.com/ENUS/SOLUTIONS/FIREDETECTIONANDALARM/PRODUCTS/CONTROLPANELS/ADDRESSABLEFIREALARMPANELS/Pages/4010FireAlarmControlPanel.aspx>
- Tyco International. (n.d.). *SimplexGrinnell History*. Retrieved April 25, 2012, from  
<http://www.simplexgrinnell.com/ENUS/ABOUTUS/Pages/SimplexGrinnellHistory.aspx>
- Tyco International, Ltd. (2012). *SimplexGrinnell - Home*. Retrieved April 25, 2012, from  
<http://www.simplex4100es.com/applications/industrial>
- Tyco International, Ltd. (2012). *Welcome to Tyco Fire & Security Asia*. Retrieved April 25, 2012, from  
Welcome to Tyco Fire & Security Asia: [http://www.tycoasia.com/about\\_us.html](http://www.tycoasia.com/about_us.html)
- Veryzer, R. W. (1993). *Aesthetic Response and the Influence of Design Principles on Product Preferences*. Association for Consumer Research.
- VITSOE. (2012, April 20). *Dieter Rams- ten principles for good design*. Retrieved from  
<http://www.vitsoe.com/en/gb/about/dieterrams/gooddesign>